





TFT Module Specification

MODEL: UC-090XIEBCBA1-S

This module uses ROHS material

CUSTOMER
APPROVED BY
DATE:

DESIGNED	CHECKED	APPROVED
		

Tel: 1 (888) 499-8477

Fax: (407) 273-0771

E-mail: mtusainfo@microtipsusa.com

Web: www.microtipsusa.com

RECORD OF REVISION

Version	Revised Date	Page	Content
V1.0	2024/05/15	--	PRELIMINARY SPEC.

TABLE OF CONTENTS

No.	Content	Page
	TFT Module Specification	1
	TABLE OF CONTENTS	3
1.	GENERAL DESCRIPTION	4
2.	MECHANICAL SPECIFICATION	5
3.	PIN DESCRIPTION	6
4.	ABSOLUTE MAXIMUM RATINGS	7
5.	BLOCK DIAGRAM	8
6.	ELECTRICAL CHARACTERISTICS	9
7.	PROJECTED CAPACITIVE TOUCH PANEL SPECIFICATIONS	10
8.	OPTICAL CHARACTERISTICS	11
9.	RELIABILITY	14
10.	PRECAUTION RELATING PRODUCT HANDLING	19

1. GENERAL DESCRIPTION

1.1 Description

The specification is model UC-090XIEBCBA1-S is a color active matrix thin film transistor (TFT) liquid crystal display (LCD) that uses amorphous silicon TFT as a switching device. This model is composed of a TFT LCD panel, a driving circuit, a backlight system and projected capacitive touch panel. This TFT LCD has a 9.0 inch diagonally measured active display area with WSVGA (1024 horizontal by 600 vertical pixels) resolution.

- ◆ Supports VESA DisplayPort Alt. Mode 1.0a
- ◆ DisplayPort 1.3
- ◆ Build-in OSD function.

1.2 Features:

No.	Item	Specification	Unit
1	Panel Size	9.0"	Inch
2	Number of Pixels	1024 (W) x RGB x 600 (H)	Pixels
3	Active Area	196.61 (W) × 114.15 (H)	mm
4	Pixel Pitch	0.192 (W) x 0.19025 (H)	mm
5	Outline Dimension	210.7 (W) × 126.4 (H) × 16.97 (T)	mm
6	Number of Colors	16.7M	--
7	Display Mode	IPS / Normally Black / Transmissive	--
8	Viewing Direction	Free direction	--
9	Display Format	RGB vertical stripe	--
10	Surface Treatment	Clear (7H)	--
11	Contrast Ratio	600 (Typ.)	--
12	Luminance (cd/m ²)	850 (Typ.)	cd/m ²
13	Interface	TYPE-C (5V/3A)	--
14	Backlight	White LED	--
15	Operation Temperature	0 ~ 70	°C
16	Storage Temperature	-30 ~ 80	°C
17	Weight	TBD	g

2. MECHANICAL SPECIFICATION

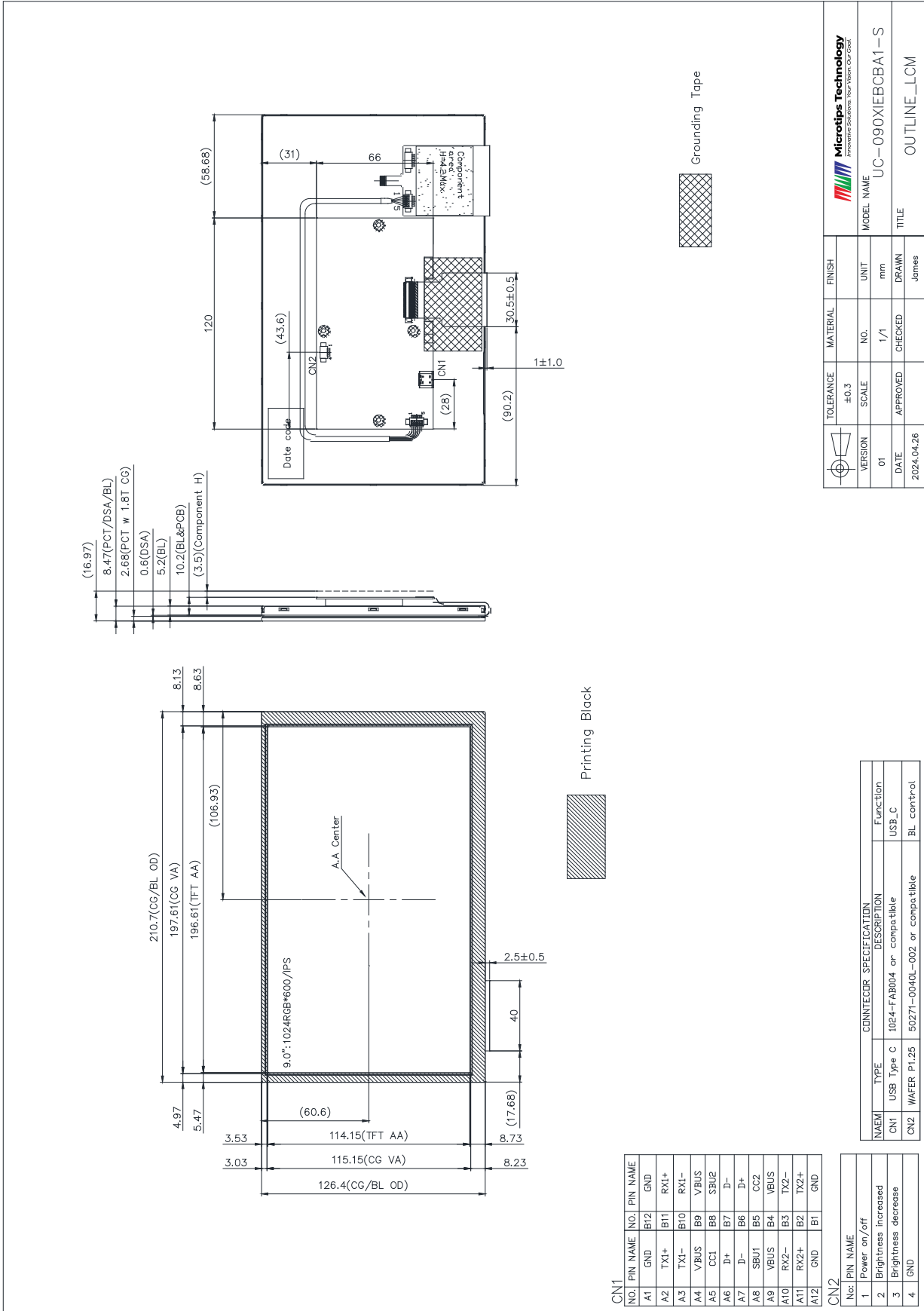

CN1

NO.	PIN NAME	NO.	PIN NAME
A1	GND	B12	GND
A2	TX1+	B11	RX1+
A3	TX1-	B10	RX1-
A4	VBUS	B9	VBUS
A5	CC1	B8	SBU2
A6	D+	B7	D-
A7	D-	B6	D+
A8	SBU1	B5	CC2
A9	VBUS	B4	VBUS
A10	RX2-	B3	TX2-
A11	RX2+	B2	TX2+
A12	GND	B1	GND

CN2

No.	PIN NAME	CONNTECDR SPECIFICATION
1	Power on/off	
2	Brightness increased	
3	Brightness decrease	
4	GND	

NAEM	TYPE	DESCRIPTION	Function
CN1	USB Type C	1024-FAB004 or compatible	USB_C
CN2	WAFER P126	50271-0040L-002 or compatible	BL control

TOLERANCE	MATERIAL	FINISH
±0.3		
VERSION	NO.	UNIT
01	1/1	mm
DATE	APPROVED	CHECKED
2024.04.26		
MODEL NAME		TITLE
UC-090XIEBCBA1-S		OUTLINE_LCM
		DRAWN
		James

3. PIN DESCRIPTION

3.1 TYPE-C CN1(Connector Part No: 1024-FAB004 or compatible)

Pin No.	Symbol	I/O	Function	Note
A1	GND	P	Ground	
A2	TX1+	I/O	High speed data path TX for DP Alt Mode.	
A3	TX1-	I/O		
A4	VBUS	P	Cable bus power +5V only.	
A5	CC1	I/O	Type-C Port Configuration Channel	
A6	D+	I/O	USB 2.0 Interface.	
A7	D-	I/O		
A8	SBU1	I/O	USB Type-C Sideband Use 1	
A9	VBUS	P	Cable bus power +5V only.	
A10	RX2-	I/O	High speed data path RX for DP Alt Mode.	
A11	RX2+	I/O		
A12	GND	P	Ground	
B1	GND	P	Ground	
B2	TX2+	I/O	High speed data path TX for DP Alt Mode.	
B3	TX2-	I/O		
B4	VBUS	P	Cable bus power +5V only.	
B5	CC2	I/O	Type-C Port Configuration Channel	
B6	D+	I/O	USB 2.0 Interface.	
B7	D-	I/O		
B8	SBU2	I/O	USB Type-C Sideband Use 2	
B9	VBUS	P	Cable bus power +5V only.	
B10	RX1-	I/O	High speed data path RX for DP Alt Mode.	
B11	RX1+	I/O		
B12	GND	P	Ground	

3.2 key Pad CN2 (50271-0040L-002 or compatible)

Pin	Symbol	I/O	Function	Note
1	Power on/off	I	Power On/Off control.	
2	Brightness increased	I	Brightness Increase.	
3	Brightness decrease	I	Brightness decrease.	
4	GND	P	Ground	

4. ABSOLUTE MAXIMUM RATINGS

4.1 Electrical Absolute Rating

4.1.1 TFT LCD Module

Item	Symbol	Values		Unit	Note
		Min	Max.		
Power supply voltage	VBUS	-0.3	6	V	

4.1.2 Environment Absolute Rating

Item	Symbol	Values			Unit	Note
		Min	Typ	Max.		
Operating Temperature	Topa	0		70	°C	Ambient temperature
Storage Temperature	Tstg	-30		80	°C	

5. BLOCK DIAGRAM

5.1 TFT LCD Module

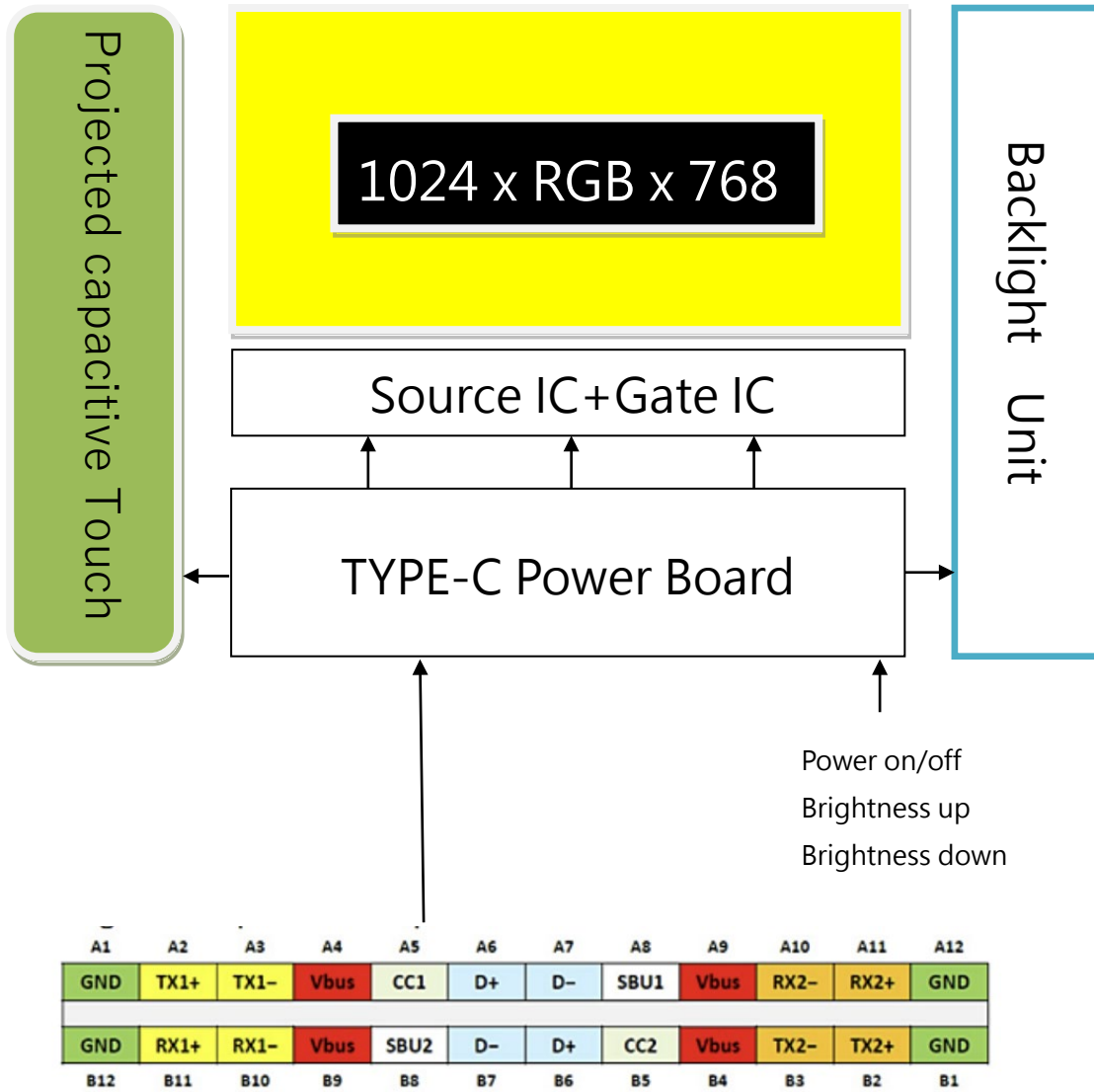

6. ELECTRICAL CHARACTERISTICS

6.1 TFT LCD Module

Item	Symbol	Values			Unit	Note
		Min.	Typ.	Max.		
Supply Voltage	VBUS	-	5.0	5.5	V	
required current	I _{BUS}	-	1030	1130	mA	(1)
LED life time	-	-	50000	-	Hr	(2)

Note 1: condition: projected capacitive touch panel active, and under brightness 100%

Note 2: The "LED life time" is defined as the module brightness decrease to 50% original brightness that the ambient temperature is 25°C 60% RH.

6.2 OSD Function

Built-in OSD function, connected to the external key pad to CN2, can control the screen switch On/Off and backlight brightness control.

The adjusted brightness level will be automatically memorized.

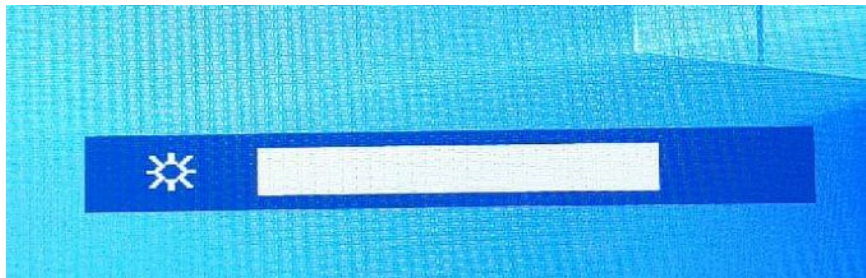

7. PROJECTED CAPACITIVE TOUCH PANEL

7.1 Main Feature

Item	Specification	Unit
Screen Size	9.0 inch	Diagonal
Type	Transparent Type Projected Capacitive	--
Input Mode	Human's Finger	--
Finger	10	--
Interface	USB	--
Cover glass pencil-hardness	7H	--
Response time	25	ms
Driver IC	ILI2511	

8. OPTICAL CHARACTERISTICS

Item	Symbol	Condition	Min.	Typ.	Max.	Unit
Brightness	--	Note1, Note 3, ($\theta = 0^\circ$; Normal Viewing Angle)	680	850	--	cd/m ²
Uniformity	B-uni		70	75	-	%
Contrast Ratio	CR		400	600	--	--
Response Time	Tr		--	17	24	ms
	Tf		--	18	26	ms
Color Chromaticity	White	Wx	0.260	0.310	0.360	--
		Wy	0.280	0.330	0.380	--
View angle	Horizontal	$\theta x+$	80	85	--	
		$\theta x-$	80	85	--	
	Vertical	$\theta Y+$	80	85	--	
		$\theta Y-$	80	85	--	

Note : The following optical specifications shall be measured in a darkroom or equivalent state (ambient luminance ≤ 1 lux, and at room temperature). The operation temperature is $25^\circ\text{C} \pm 2^\circ\text{C}$. The measurement method is shown in Note1.

Note 1: The method of optical measurement:

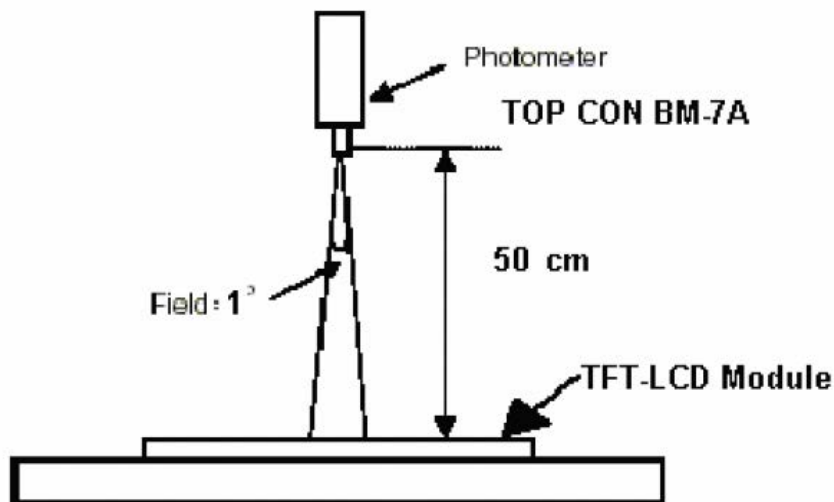

Note 2: Measured at the center area of the panel and at the viewing angle of the $\theta x = \theta y = 0^\circ$

Note 3: Definition of Contrast Ratio (CR):

CR = Luminance with all pixels in white state \div Luminance with all pixels in Black state

Note 4: Definition of Viewing Angle:

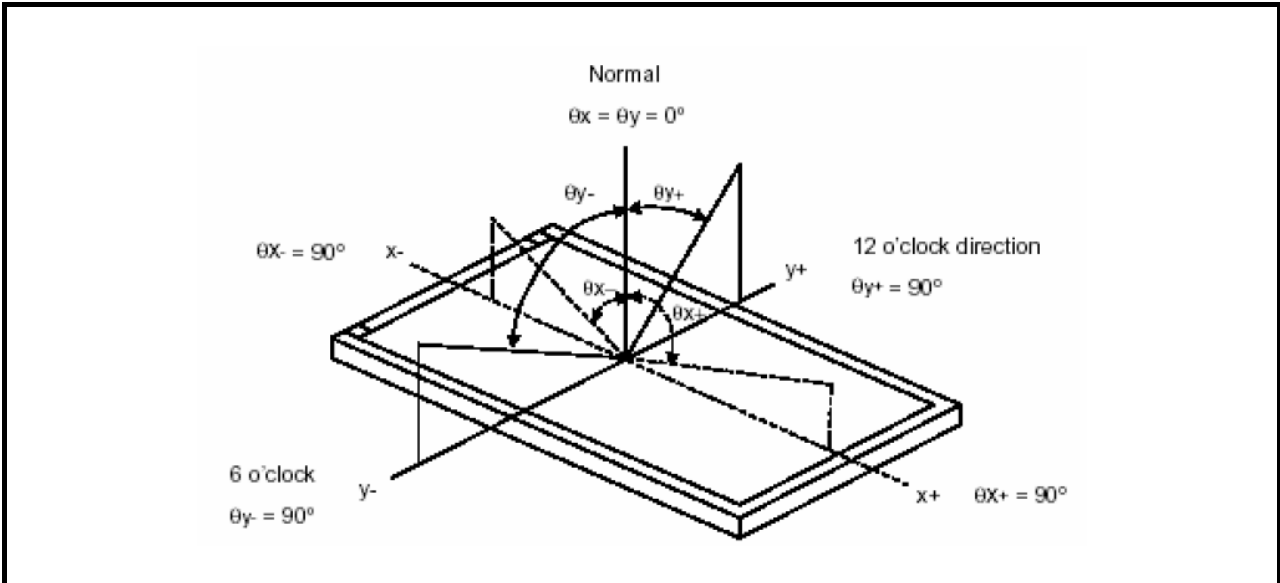

Note 5: Definition of Brightness Uniformity (B-uni):

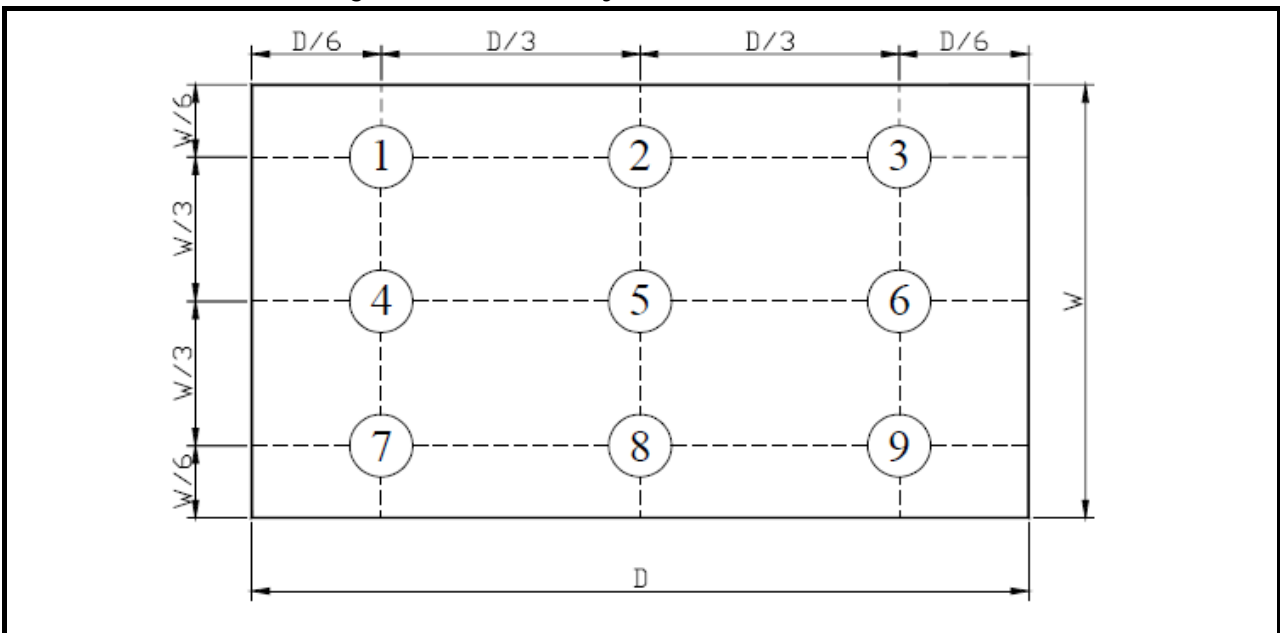

$$B\text{-uni} = (\text{Minimum luminance of 9 points} \div \text{Maximum luminance of 9 points}) \times 100\%$$

Note 6: Definition of Response Time:

The Response Time is set initially by defining the “Rising Time (T_r)” and the “Falling Time (T_f)” respectively. T_r and T_f are defined as following figure

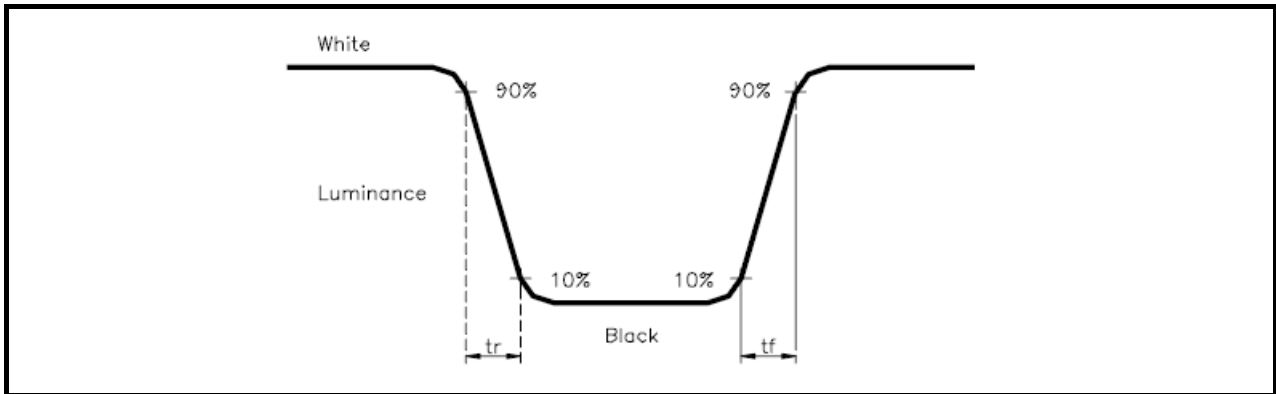

Note 7: Definition of Chromaticity:

The color coordinates (W_x, W_y), (R_x, R_y), (G_x, G_y), and (B_x, B_y) are obtained with all pixels in the viewing field at white, red, green, and blue states, respectively.

9. RELIABILITY

9.1 Test Condition

9.1.1 Temperature and Humidity(Ambient Temperature)

Temperature : $25 \pm 5^{\circ}\text{C}$

Humidity : $65 \pm 5\%$

9.1.2 Operation

Unless specified otherwise, test will be conducted under function state.

9.1.3 Container

Unless specified otherwise, vibration test will be conducted to the product itself without putting it in a container.

9.1.4 Test Frequency

In case of related to deterioration such as shock test. It will be conducted only once.

9.2 TESTS

No.	ITEM	CONDITION CRITERION
1	High Temperature Storage	80°C, 120 hrs
2	Low Temperature Storage	-30°C, 120 hrs
3	High Temperature Operating	70°C, 120 hrs
4	Low Temperature Operating	0°C, 120 hrs
5	High Temperature/Humidity Non-Operating	50°C, 90%RH, 120 hrs
6	Temperature Shock Non-Operating	-30°C \leftrightarrow 70°C (0.5hr each), 25 cycles
7	Vibration Test Non-Operating	Frequency:0 ~ 55 Hz Amplitude:1.5 mm Sweep Time:11min Test Period:6 Cycles for each Direction of X,Y,Z
9	Electro-static Discharge Non-Operating	150pF,330Ω Air:± 8KV;Contact: ±4KV 10 times/point;4 points/panel face

Note1: The test sample have recovery time for 24 hours at room temperature before the function check. In the standard conditions, there is no any touch panel function NG issue occurred.

9.3 JUDGMENT STANDARD

The judgment of the above test should be made as follow:

Pass: Normal display image with no obvious non-uniformity and no line defect. Partial transformation of the module parts should be ignored.

Fail: No display image, obvious non-uniformity, or line defects.

9.4 INCOMING INSPECTION STANDARDS

No.	Parameter	Criteria										
1	Operating	Display function: No Display malfunction (Major)										
		Contrast ratio (Black, White): Does not meet specified range in the spec. (Major) (Note:3)										
		Line Defect: No obvious Vertical and Horizontal line defect in bright, dark and colored. (Major) (Note:1)										
		Point Defect : Active area ≤ 5 dots (Minor) (Note:1)										
		<table border="1"> <thead> <tr> <th rowspan="2">Item</th> <th>Acceptable number</th> <th rowspan="2">Total</th> </tr> <tr> <th>Active Area</th> </tr> </thead> <tbody> <tr> <td>Bright</td> <td>2</td> <td rowspan="2">5</td> </tr> <tr> <td>Dark</td> <td>4</td> </tr> </tbody> </table>	Item	Acceptable number	Total	Active Area	Bright	2	5	Dark	4	
		Item		Acceptable number		Total						
Active Area												
Bright	2	5										
Dark	4											
Non-uniformity: Visible through 5%ND filter. (Minor)												
Foreign material in Black or White spots shape ($W > 1/4L$)												
<table border="1"> <thead> <tr> <th>Zone Dimension</th> <th>Acceptable number</th> <th rowspan="3">Class Of Defects</th> <th rowspan="3">AQL Level</th> </tr> </thead> <tbody> <tr> <td>$D > 0.5$</td> <td>0</td> </tr> <tr> <td>$0.3 < D \leq 0.5$</td> <td>5</td> </tr> <tr> <td>$D \leq 0.3$</td> <td>*</td> <td>Minor</td> <td>1.5</td> </tr> </tbody> </table> <p>$D = (\text{Long} + \text{Short}) / 2$ * : Disregard</p>	Zone Dimension	Acceptable number	Class Of Defects	AQL Level	$D > 0.5$	0	$0.3 < D \leq 0.5$	5	$D \leq 0.3$	*	Minor	1.5
Zone Dimension	Acceptable number	Class Of Defects			AQL Level							
$D > 0.5$	0											
$0.3 < D \leq 0.5$	5											
$D \leq 0.3$	*	Minor	1.5									
Foreign Material in Line or spiral shape ($W \leq 1/4L$) (Note: 4)												
<table border="1"> <thead> <tr> <th>L (mm) \ Zone W(mm)</th> <th>Acceptable number</th> <th rowspan="3">Class Of Defects</th> <th rowspan="3">AQL Level</th> </tr> </thead> <tbody> <tr> <td>$L > 5$ $W > 0.1$</td> <td>0</td> </tr> <tr> <td>$0.5 < L \leq 5$ $0.03 < W \leq 0.1$</td> <td>5</td> </tr> <tr> <td>$L \leq 0.5$ $W \leq 0.03$</td> <td>*</td> <td>Minor</td> <td>1.5</td> </tr> </tbody> </table> <p>L : Length W : Width * : Disregard</p>	L (mm) \ Zone W(mm)	Acceptable number	Class Of Defects	AQL Level	$L > 5$ $W > 0.1$	0	$0.5 < L \leq 5$ $0.03 < W \leq 0.1$	5	$L \leq 0.5$ $W \leq 0.03$	*	Minor	1.5
L (mm) \ Zone W(mm)	Acceptable number	Class Of Defects			AQL Level							
$L > 5$ $W > 0.1$	0											
$0.5 < L \leq 5$ $0.03 < W \leq 0.1$	5											
$L \leq 0.5$ $W \leq 0.03$	*	Minor	1.5									
2	External Inspection (non-operating)	Dimension: Outline (Major)										
		Bezel appearance: uneven (Minor)										
		Scratch on the polarize: (Note:2)										
		<table border="1"> <thead> <tr> <th>L (mm) \ Zone W(mm)</th> <th>Acceptable number</th> <th rowspan="2">Class Of Defects</th> <th rowspan="2">AQL Level</th> </tr> </thead> <tbody> <tr> <td>-- $W > 0.1$</td> <td>0</td> </tr> <tr> <td>$L \leq 3$ $W \leq 0.1$</td> <td>3</td> <td>Minor</td> <td>1.5</td> </tr> </tbody> </table> <p>L : Length W : Width * : Disregard</p>	L (mm) \ Zone W(mm)	Acceptable number	Class Of Defects	AQL Level	-- $W > 0.1$	0	$L \leq 3$ $W \leq 0.1$	3	Minor	1.5
		L (mm) \ Zone W(mm)	Acceptable number	Class Of Defects			AQL Level					
-- $W > 0.1$	0											
$L \leq 3$ $W \leq 0.1$	3	Minor	1.5									
Dent or bubble on the polarize (Note:2)												
<table border="1"> <thead> <tr> <th>Zone Dimension</th> <th>Acceptable number</th> <th rowspan="2">Class Of Defects</th> <th rowspan="2">AQL Level</th> </tr> </thead> <tbody> <tr> <td>$D \leq 0.3$</td> <td>*</td> </tr> <tr> <td>$D \leq 0.5$</td> <td>3</td> <td>Minor</td> <td>1.5</td> </tr> </tbody> </table> <p>$D = (\text{Long} + \text{Short}) / 2$ * : Disregard</p>	Zone Dimension	Acceptable number	Class Of Defects	AQL Level	$D \leq 0.3$	*	$D \leq 0.5$	3	Minor	1.5		
Zone Dimension	Acceptable number	Class Of Defects			AQL Level							
$D \leq 0.3$	*											
$D \leq 0.5$	3	Minor	1.5									

Class of defects			Definition
	Major	AQL 0.65%	It is a defect that is likely to result in failure or to reduce materially the usability of the product for the intended function.
Minor	AQL 1.5%	It is a defect that will not result in functioning problem with deviation classified.	

Note1:

(a) Bright point defect is defined as point defect of R,G,B with area $>1/2$ pixel respectively

(b) Dark point defect is defined as visible in full white pattern.

(c) Definition of distribution of point defect is as follows:

- minimum separation between dark point defects should be larger than 5mm.
- minimum separation between bright point defects should be larger than 5mm.

(d) Definition of joined bright point defect and joined dark point defect are as follows:

- Two or more joined bright point defects must be nil.
- Three joined dark point defects must be nil.
- Coupling of one dark and one bright point in junction is counted as one dark and bright spot with 1 pair maximum.
- Two Joined dark point is counted as two dark points with 2 pair maximum.

Note2: The external inspection should be conducted at the distance 30 ± 5 cm between the eyes of inspector and the panel.

Note3: Luminance measurement for contrast ratio is at the distance 50 ± 5 cm between the detective head and the panel with ambient luminance less than 1 lux. Contrast ratio is obtained at optimum view angle.

Note4: W-Width in mm , L-length of Max.(L1,L2) in mm.

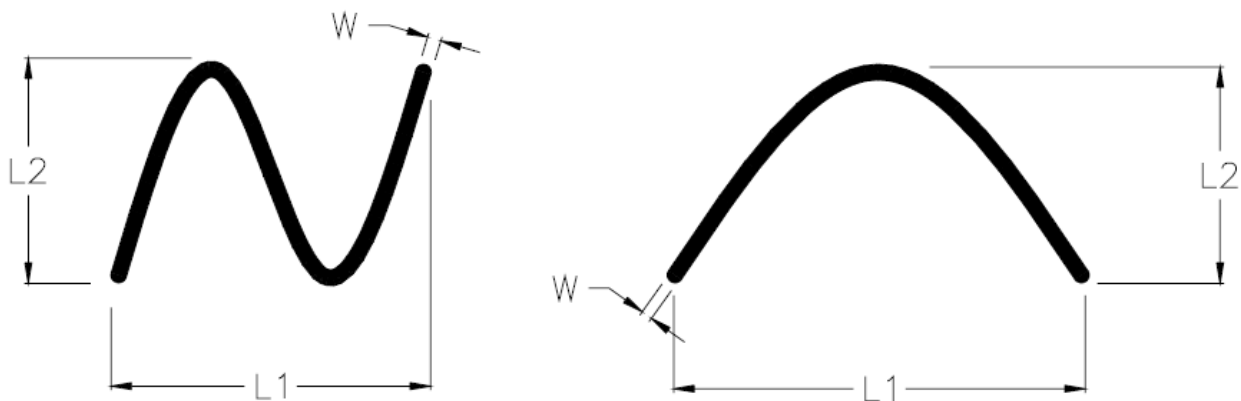

9.5 Sampling Condition

Unless otherwise agree in written, the sampling inspection shall be applied to the incoming inspection of customer.

Lot size: Quantity of shipment lot per model.

Sampling type: normal inspection, single sampling

Sampling table: MIL-STD-105E

Inspection level: Level II

9.6 Inspection conditions

The LCD shall be inspected under 40W white fluorescent light.

$\theta \leq 45^\circ$ inspection under non-operating condition.

$\theta \leq 5^\circ$ inspection under operating condition

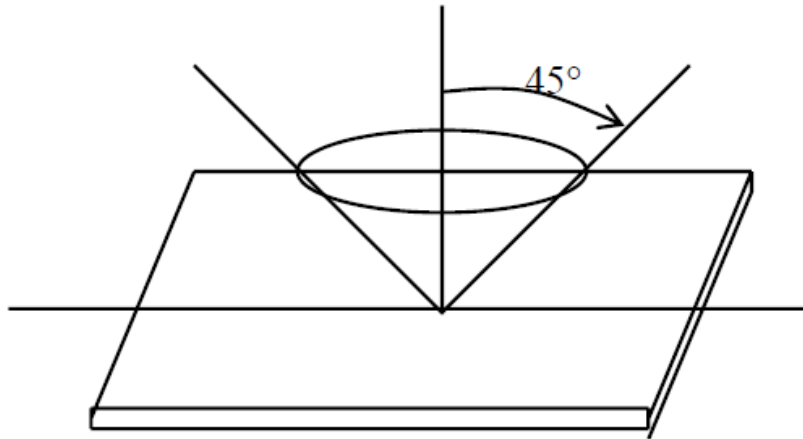

10. PRECAUTION RELATING PRODUCT HANDLING

10.1 SAFETY

10.1.1 If the LCD panel breaks , be careful not to get the liquid crystal to touch your skin.

10.1.2 If the liquid crystal touches your skin or clothes , please wash it off immediately by using soap and water.

10.2 HANDLING

10.2.1 Avoid any strong mechanical shock which can break the glass.

10.2.2 Avoid static electricity which can damage the CMOS LSI—When working with the module, be sure to ground your body and any electrical equipment you may be using.

10.2.3 Do not remove the panel or frame from the module.

10.2.4 The polarizing plate of the display is very fragile. So , please handle it very carefully, Do not touch, push or rub the exposed polarizing with anything harder than an HB pencil lead (glass , tweezers , etc.)

10.2.5 Do not wipe the polarizing plate with a dry cloth, as it may easily scratch the surface of plate.

10.2.6 Do not touch the display area with bare hands , this will stain the display area.

10.2.7 Do not use ketonics solvent & aromatic solvent. Use with a soft cloth soaked with a cleaning naphtha solvent.

10.2.8 To control temperature and time of soldering is $280 \pm 10^{\circ}\text{C}$ and 3-5 sec.

10.2.9 To avoid liquid (include organic solvent) stained on LCM.

10.3 STORAGE

10.3.1 Store the panel or module in a dark place where the temperature is $25^{\circ}\text{C} \pm 5^{\circ}\text{C}$ and the humidity is below 65% RH.

10.3.2 Do not place the module near organics solvents or corrosive gases.

10.3.3 Do not crush, shake, or jolt the module.