

CL

High-Q Ceramic Core Inductor Series (CL Series – 1008 Case Size)

High-Q Ceramic Core Inductor Range

These inductors deliver high energy efficiency and consistent inductance across a broad frequency range, making them ideal for designs in the medical and defence markets. Knowles can design inductors where Q meets or exceeds industry leader inductors. These designs are also non-magnetic and comply with MRI industry non-magnetic requirements.

Applications Include:

- RF Transceivers
- MRI Applications
- Military Radio Systems
- Antenna
- Radar Systems
- RF Testing and Measurements

Electrical Details	
CL1008	
Inductance Range	12nH – 10µH
Core Material	Ceramic
Environmental	RoHS Compliant, Halogen Free
Moisture Sensitivity Level (MSL)	1
Operating temperature range	-55°C / +125°C
Packaging	7" Tape & Reel, 2000 pcs 13" Tape & Reel, 7000 pcs

Typical Q vs Frequency

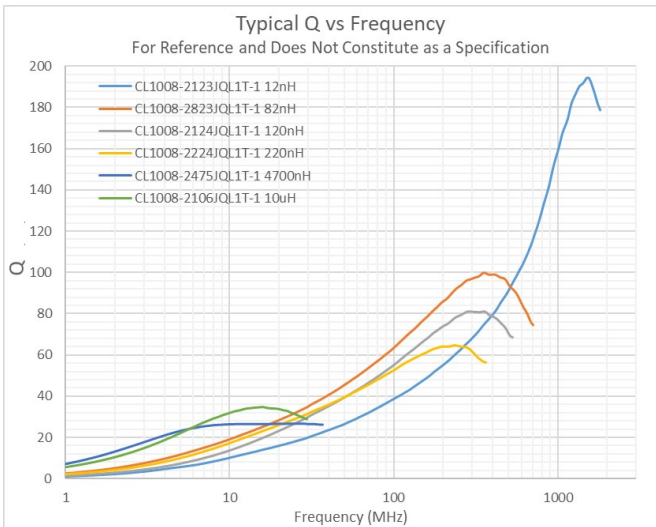

Typical L vs Frequency

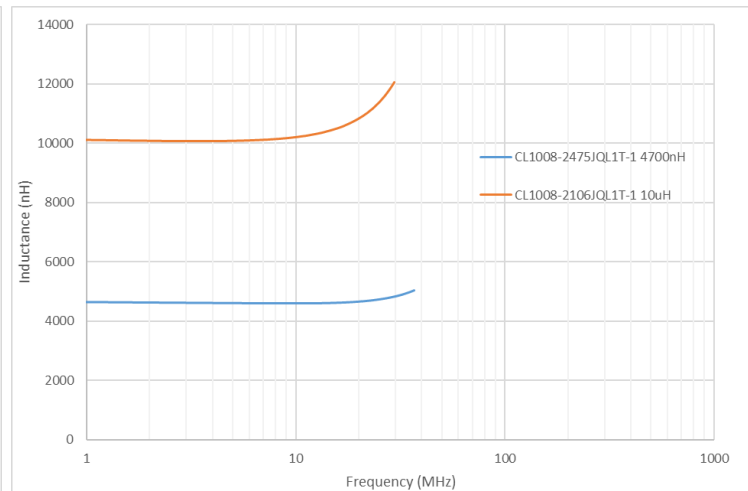
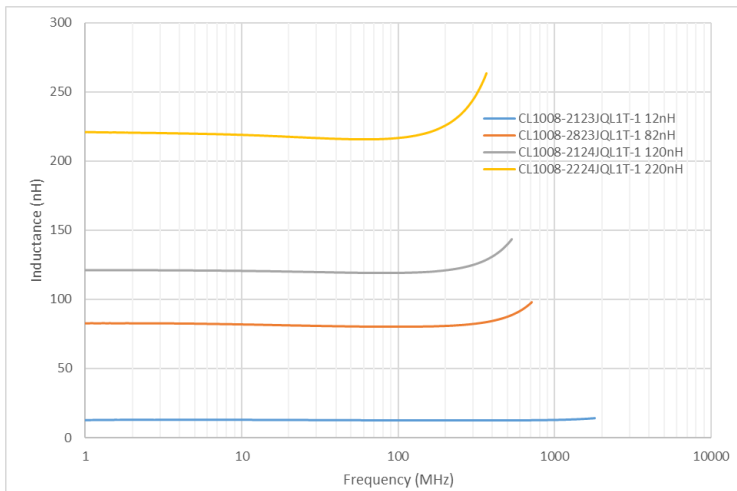

Dimensions

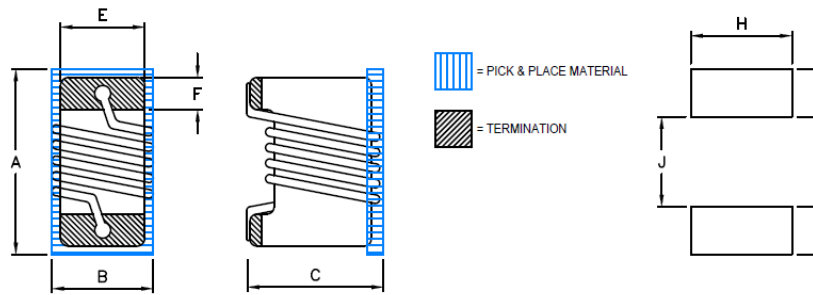

	A max	B max	C max	E	F	H	I	J
mm	2.920	2.79	2.03	2.03	0.51	2.54	1.02	1.27
in	0.115	0.110	0.080	0.080	0.020	0.100	0.040	0.050

Specifications

Part Number	Inductance* (nH)	Inductance Tolerance	Q min	SRF (MHz)	DC Resistance (Ohm) Max	Current rating 85°C (mA)	Current rating 125°C (mA)
CL1008-2123JQL1T-1	12 @ 50 MHz	5%	50 @ 500 MHz	3300	0.09	1000	1000
CL1008-2223JQL1T-1	22 @ 50 MHz	5%	55 @ 350 MHz	2400	0.12	1000	500
CL1008-2333JQL1T-1	33 @ 50 MHz	5%	60 @ 350 MHz	1600	0.14	1000	500
CL1008-2563JQL1T-1	56 @ 50 MHz	5%	65 @ 350 MHz	1300	0.18	1000	500
CL1008-2823JQL1T-1	82 @ 50 MHz	5%	60 @ 350 MHz	1200	0.22	730	370
CL1008-2104JQL1T-1	100 @ 50 MHz	5%	60 @ 350 MHz	1000	0.18	650	330
CL1008-2124JQL1T-1	120 @ 50 MHz	5%	60 @ 350 MHz	900	0.63	600	300
CL1008-2154JQL1T-1	150 @ 25 MHz	5%	45 @ 100 MHz	850	0.7	540	270
CL1008-2224JQL1T-1	220 @ 50 MHz	5%	45 @ 100 MHz	650	0.84	490	250
CL1008-2274JQL1T-1	270 @ 25 MHz	5%	45 @ 100 MHz	600	0.91	480	240
CL1008-2334JQL1T-1	330 @ 25 MHz	5%	45 @ 100 MHz	570	1.05	470	240
CL1008-2474JQL1T-1	470 @ 50 MHz	5%	45 @ 100 MHz	450	1.17	470	240
CL1008-2684JQL1T-1	680 @ 25 MHz	5%	45 @ 100 MHz	375	1.47	400	200
CL1008-2824JQL1T-1	820 @ 25 MHz	5%	45 @ 100 MHz	350	1.61	400	200
CL1008-2105JQL1T-1	1000 @ 25 MHz	5%	35 @ 50 MHz	290	1.75	370	190
CL1008-2225JQL1T-1	2200 @ 7.9 MHz	5%	28 @ 50 MHz	160	2.8	280	140
CL1008-2275JQL1T-1	2700 @ 7.9 MHz	5%	22 @ 25 MHz	140	3.2	280	140
CL1008-2335JQL1T-1	3300 @ 7.9 MHz	5%	22 @ 25 MHz	110	3.4	280	140
CL1008-2395JQL1T-1	3900 @ 7.9 MHz	5%	20 @ 25 MHz	100	3.6	260	130
CL1008-2475JQL1T-1	4700 @ 7.9 MHz	5%	20 @ 25 MHz	90	4	260	130
CL1008-2106JQL1T-1	10000 @ 2.5 MHz	5%	20 @ 7.9 MHz	20	12	140	70

*Special inductances available upon request

Ordering Information – CL Inductance Series

CL1008	- 2	103	J	Q	L	1	T	- 1
Chip Size	Termination	Inductance in NanoHenry (nH)	Inductance Tolerance	High-Q Type	Inductance Code	Version	Packaging	Suffix
1008	2 = Sintered silver base with copper barrier (100% matte tin plating). RoHS compliant.	First digit is 0. First and second digits are significant figures of capacitance code. The third digit is the number of zeros following. e.g., 103 = 10nH Values are E24 series	G: ± 2% J: ± 5%		L = Inductance		T = Tape & Reel, 7" R = Tape & Reel, 13"	1 = Standard

List of Measurement Tools

1. Inductance measured using a Keysight E4991B with an 16197A Bottom electrode SMD Test Fixture
2. Q measured using a Keysight E4991B with an 16197A Bottom electrode SMD Test Fixture
3. SRF measured using a Keysight E4991B with an 16197A Bottom electrode SMD Test Fixture
4. DCR measured using HP4285A with pin testing jig
5. Electrical specifications at 25 °C

Soldering Information:

Reflow Soldering Conditions:

Pre-heating should be in such a way that the temperature difference between solder and ceramic surface is limited to 150°C max. Also cooling into solvent after soldering should be in such a way that the temperature difference is limited to 100°C max. Insufficient pre-heating may cause cracks on the ceramic, resulting in the deterioration of product quality. Products should be soldered within the following allowable range indicated by the slanted line. The excessive soldering conditions may cause the corrosion of the electrode, when soldering is repeated, allowable time is the accumulated time.

Reflow solder in accordance with IPC-A-610. Recommended reflow profile as laid down in IPC/JEDEC J-STD-020.

Wave soldering is also possible, but care must be taken for case sizes 1210 and larger and component thickness >1.0mm. Trials are encouraged.

Hand soldering is not recommended and can lead to component damage through thermal shock.

PdAg terminations are primarily intended for conductive epoxy attachment - they may be suitable for soldering but trials are recommended.

Application notes with mounting and handling guidance are available on request.

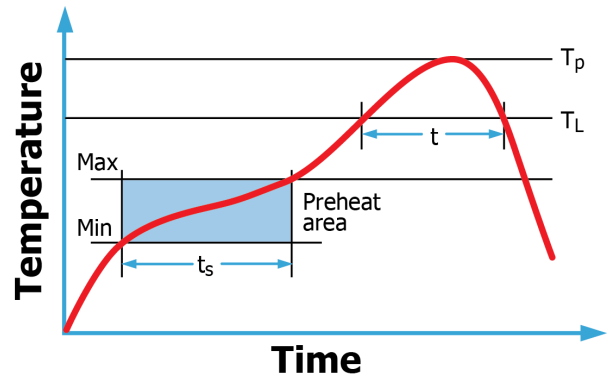

Reworking with soldering iron:

Reworking should be limited to only one time.

Note: Do not directly touch the products with the tip of the soldering iron in order to prevent the crack on the material due to thermal shock.

Preheating	150°C, 1 minute
Tip Temperature	280°C max
Soldering Time	3 seconds max.
Soldering Iron Output	30w max.
End of Soldering Iron	3mm max.

Solder Volume:

Solder shall be used not to be exceeding the upper limits as shown below.

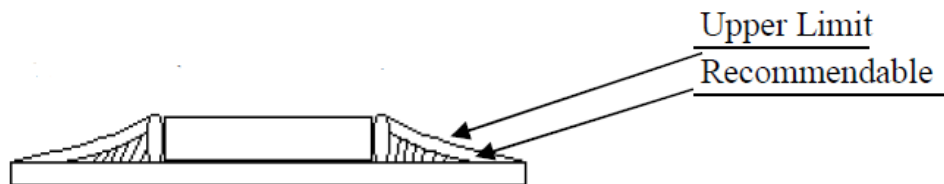

When the amount of solder volume increases, mechanical stress increases as well. Exceeding the amount of solder volume may lead to failure of mechanical or electronic characteristics.

Packaging Information

Tape and reel packing of surface mounting chip capacitors for automatic placement are in accordance with IEC60286-3.

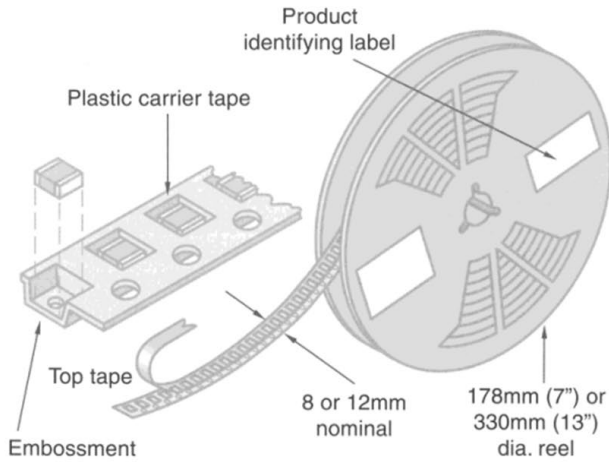

Reel Dimensions

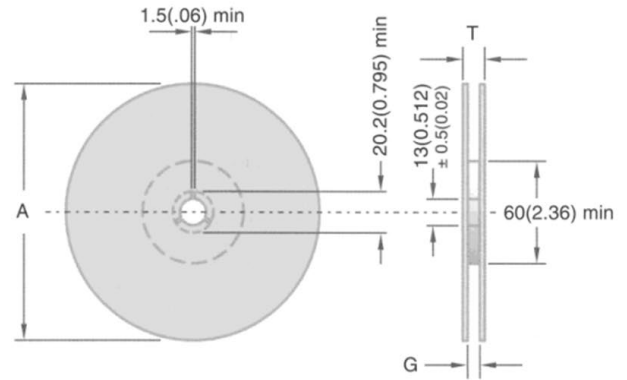

Symbol	Description	178mm Reel	330mm Reel
A	Reel diameter	178 (7)	330 (13)
G	Reel inside width	8.4 (0.33)	12.4 (0.49)
T	Reel outside width	14.4 (0.56) max	18.4 (0.72) max

Peel Force

The peel force of the top sealing tape is between 0.2 and 1.0 Newton at 180°. The breaking force of the carrier and sealing tape in the direction of unreeling is greater than 10 Newton.

Tape Dimensions

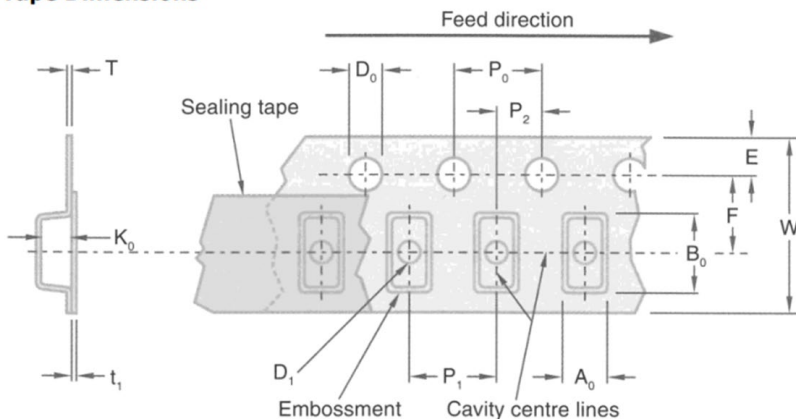

Symbol	Description	Dimensions mm (inches)	
		8mm Tape	12mm Tape
A ₀	Width of cavity	Dependent on chip size to minimize rotation	
B ₀	Length of cavity	Dependent on chip size to minimize rotation	
K ₀	Depth of cavity	Dependent on chip size to minimize rotation	
W	Width of tape	8.0 (0.315)	12.0 (0.472)
F	Distance between drive hole centres and cavity centres	3.5 (0.138)	5.5 (0.213)
E	Distance between drive hole centres and tape edge	1.75 (0.069)	
P ₁	Distance between cavity centres	4.0 (0.156)	8.0 (0.315)
P ₂	Axial distance between drive hole centres and cavity centres	2.0 (0.079)	
P ₀	Axial distance between drive hole centres	4.0 (0.156)	
D ₀	Drive hole diameter	1.5 (0.059)	
D ₁	Diameter of cavity piercing	1.0 (0.039)	1.5 (0.059)
T	Carrier tape thickness	0.22 (0.009) ±0.05 (0.002)	0.4 (0.016) ±0.1 (0.04)
t ₁	Top tape thickness	0.1 (0.004) max	

Mechanical Characteristics:

ITEM	Test Condition	Specification
Inductance	Part measured at Frequency (See Product Table)	Meets Requirements
Quality Factor		

Electrical Characteristics:

ITEM	Test Condition	Specification
Push Test	PCB mounted component. Force applied for 60s	1008 series - $\geq 1.0\text{Kg}$
Temperature Cycling Test	10 cycles consisting of: -55°C for 30mins, 25°C for 15mins and 125°C for 30 mins.	Change In Inductance: No more than 5%
High Temperature Storage	125°C for 1000hr Unpowered	
Humidity Bias	85°C/85%RH $\pm 2^\circ\text{C}$ for 1000hr Unpowered	
High Temperature Operating Life at 85°C	85°C for 1000hr Powered at rated current	
High Temperature Operating Life at 125°C	125°C for 1000hr Powered at rated current	
Resistance to Solvents	MIL-STD-202 Method 215	No Damage
Mechanical Shock & Vibration	Vibrations of 5 gs for 20 minutes, 12 cycles for 3 orientations	Change In Inductance: No more than 5%
Substrate Bend Test	3-point bend of substrate to 2mm deflection (AEC-Q200-005)	No Damage
ESD	Classification 6 $\geq 25,000\text{ V}$ (Air Discharge)	Change In Inductance: No more than 5%

Contact Knowles	Europe:	KPD-Europe-sales@knowles.com
	Asia:	KPD-Asia-sales@knowles.com
	USA:	KPD-NA-sales@knowles.com