

## 1500 VA, 48 Vdc to 230 Vac, DC-AC converter for UPS

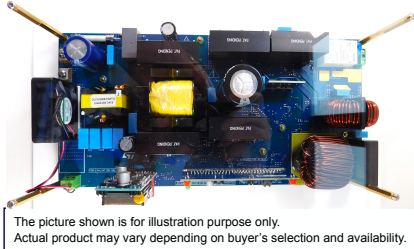

The picture shown is for illustration purpose only. Actual product may vary depending on buyer's selection and availability.

### Features

- 1500 VA digitally controlled power inverter
- Full bridge LLC + full bridge rectification + H-bridge inverter
  - LLC working in open-loop at resonant frequency to have maximum efficiency of DC-DC stage
- Output voltage: 230 V ac  $\pm$  10%
- Output THD: <5% for load >20% of maximum capability (resistive load)
- Input voltage range: 42 – 54 V dc
- Efficiency: > 93.2% at 50% of load (peak), > 92.1% at 100% of load
- Built-in comprehensive safety mechanisms
  - Low and high input voltage cutoff
  - Low and high output voltage cutoff
  - Output over current/over load protection
  - No-load protection
  - Input reverse polarity protection

### Description

The **STEVAL-DCAC1KCB** is a dual-stage digitally controlled DC-AC power inverter evaluation board.

The modular design approach makes it easier for the user to test and debug the various sections involved.

The system consists of a power inverter board, auxiliary power supply board, and a microcontroller board.

The DC-DC step-up conversion is based on a full bridge LLC resonant topology, while the DC-AC conversion is based on an H-bridge inverter.

The LLC resonant circuit is designed to operate at a fixed resonant frequency without regulating the DC-DC converter output voltage, and the open-loop operation.

The AC output voltage is regulated by varying the modulation index (MI) of the H-bridge stage.

The fixed operating frequency of the LLC converter ensures maximum efficiency irrespective of battery voltage and extends the battery back-up time. The DC-DC stage open loop operation also means lower computational load on the microcontroller.

Product summary	
1500 VA, 48 Vdc to 230 Vac, DC-AC converter for UPS	<b>STEVAL-DCAC1KCB</b>
Mainstream Arm Cortex-M4 MCU 170 MHz with 512 Kbytes of Flash memory, Math Accelerator, HR Timer, High Analog level integration	<b>STM32G474RE</b>
N-channel 80 V, 4.0 mOhm typ., 120 A STripFET F7 Power MOSFET in a PowerFLAT 5x6 package	<b>STL120N8F7</b>
N-channel 600 V, 67 mOhm typ., 46 A MDmesh DM6 Power MOSFET in a TO-LL package	<b>STO65N60DM6</b>
Galvanically isolated 4 A half-bridge dual channel gate driver	<b>STGAP2D</b>
Applications	Battery Storage Systems for Home On Board Charger (OBC) Uninterruptable power supplies (UPS)

## 1 1500 VA digitally controlled power inverter architecture

The DC-DC converter based on LLC resonant topology starts with a frequency of 250 kHz to have a soft start and settles down at 75 kHz resonant frequency for the steady state operation.

The turns ratio of the LLC transformer has been kept slightly higher to ensure sufficient DC link voltage even when the battery is at 42 V.

The inverter stage is based on an H-bridge topology which takes input from an LLC resonant converter and generates an AC output voltage.

To have a tightly regulated output, it is continuously monitored, and the modulation index (MI) of the H-bridge is adjusted based on the PI control loop implemented within the microcontroller.

In H-bridge converter one half-bridge works on high frequency while the other half-bridge works on in H-bridge converter one half-bridge works on high frequency while the other half-bridge works on.

**Figure 1. 1500 VA power inverter architecture**

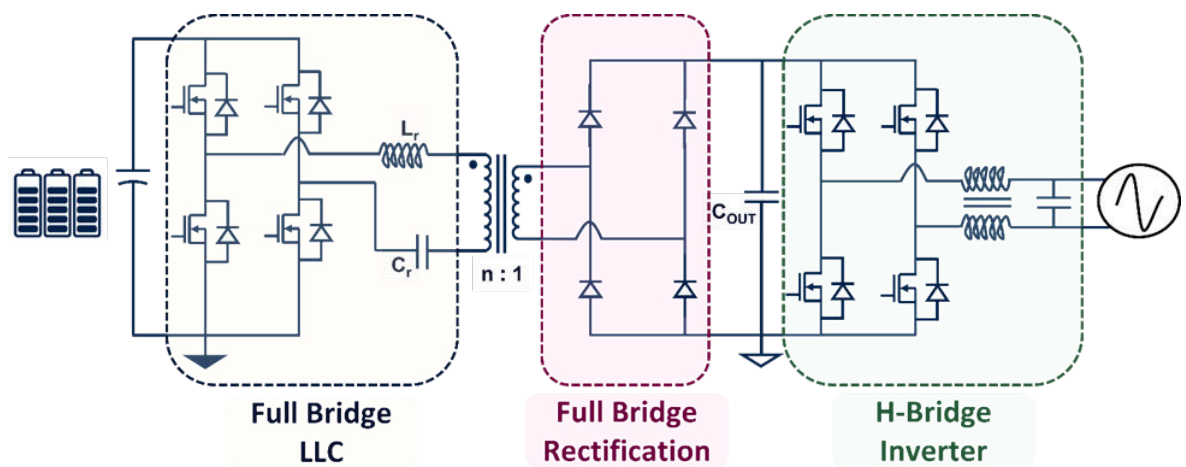

## 2 STEVAL-DCAC1KCB block diagram

Figure 2. STEVAL-DCAC1KCB block diagram with key ST components

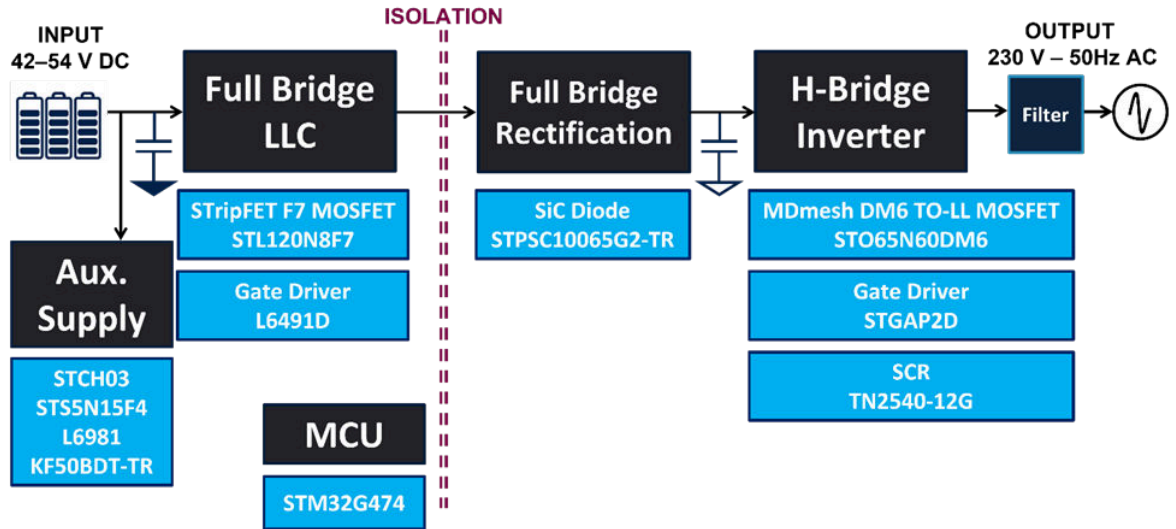

### 3 Schematic diagrams

Notice: These schematics are for illustration purpose only. Actual product may vary depending on buyer's selection and availability.

Figure 3. STEVAL-DCAC1KCB - Circuit schematic

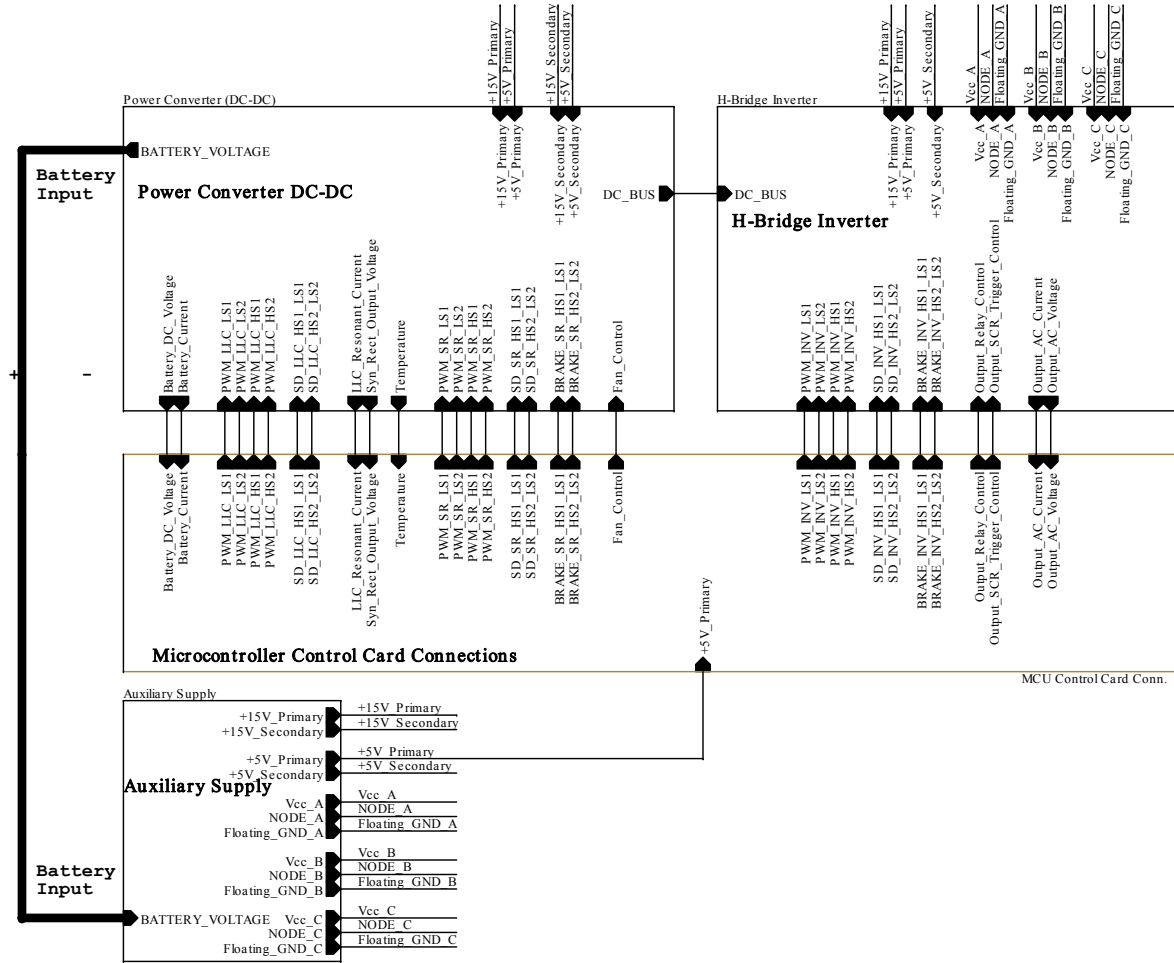

Figure 4. STEVAL-DCAC1KCB: auxiliary supply - Circuit schematic

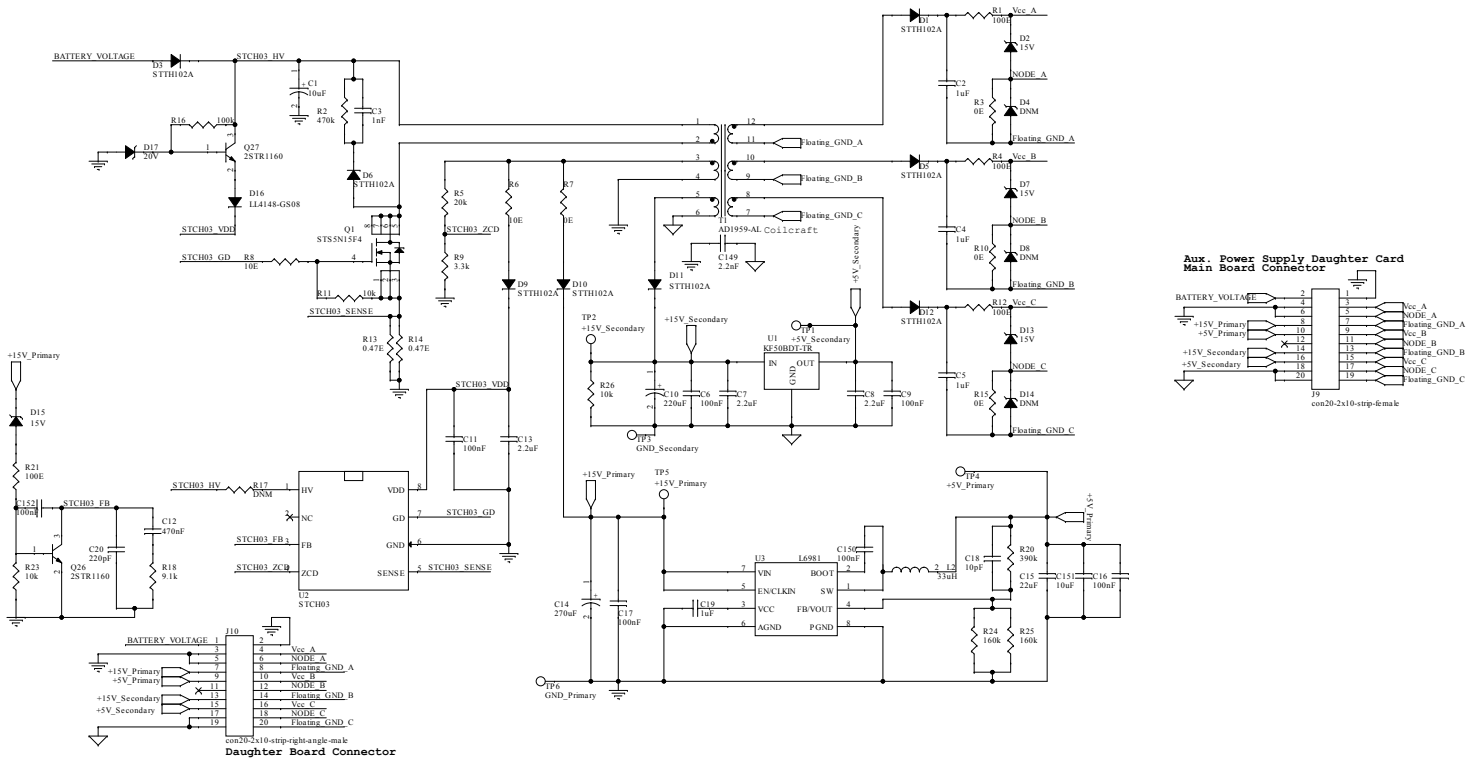

Figure 5. STEVAL-DCAC1KCB: H-bridge inverter - Circuit schematic

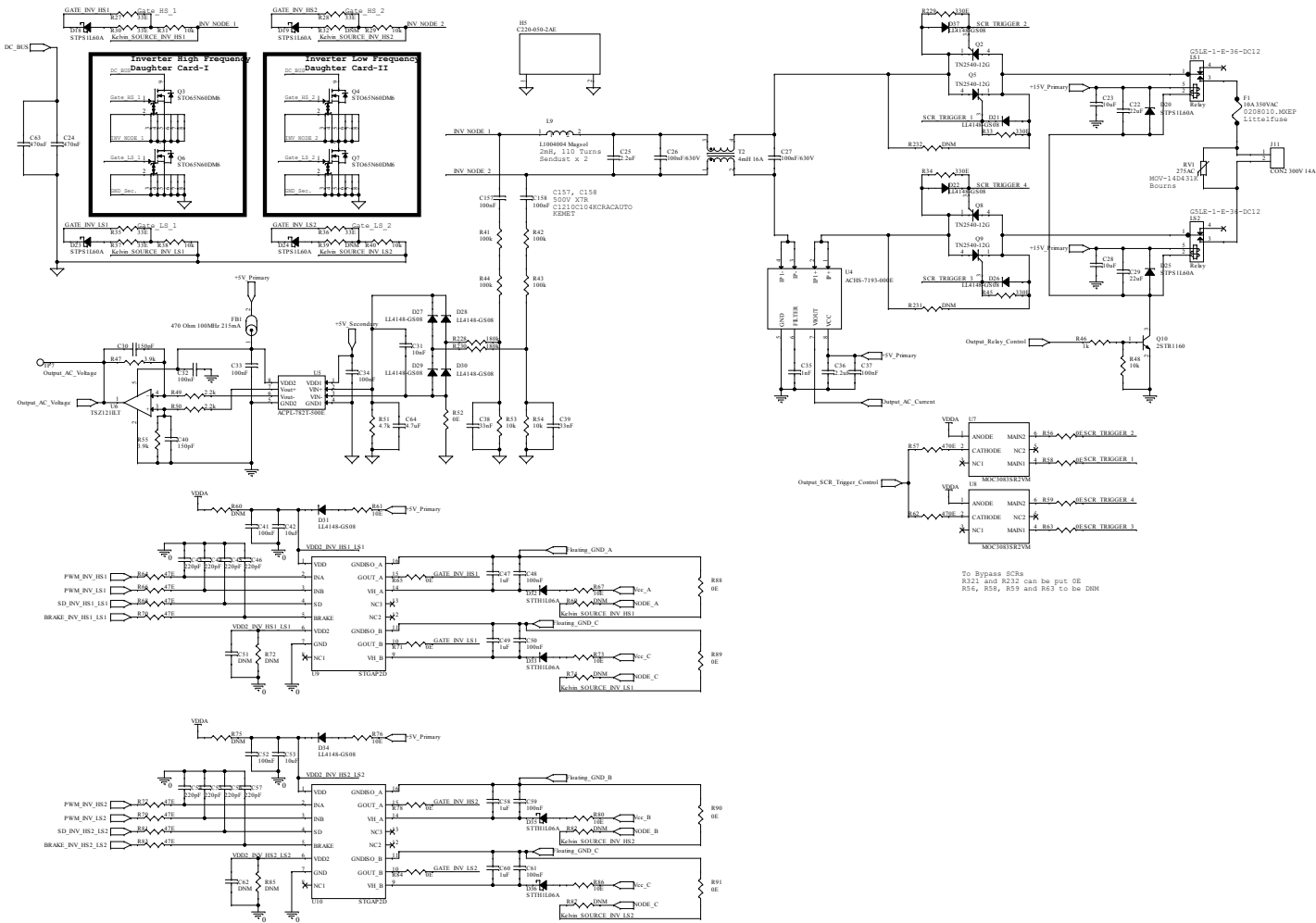

Figure 6. STEVAL-DCAC1KCB: microcontroller control card connections - Circuit schematic

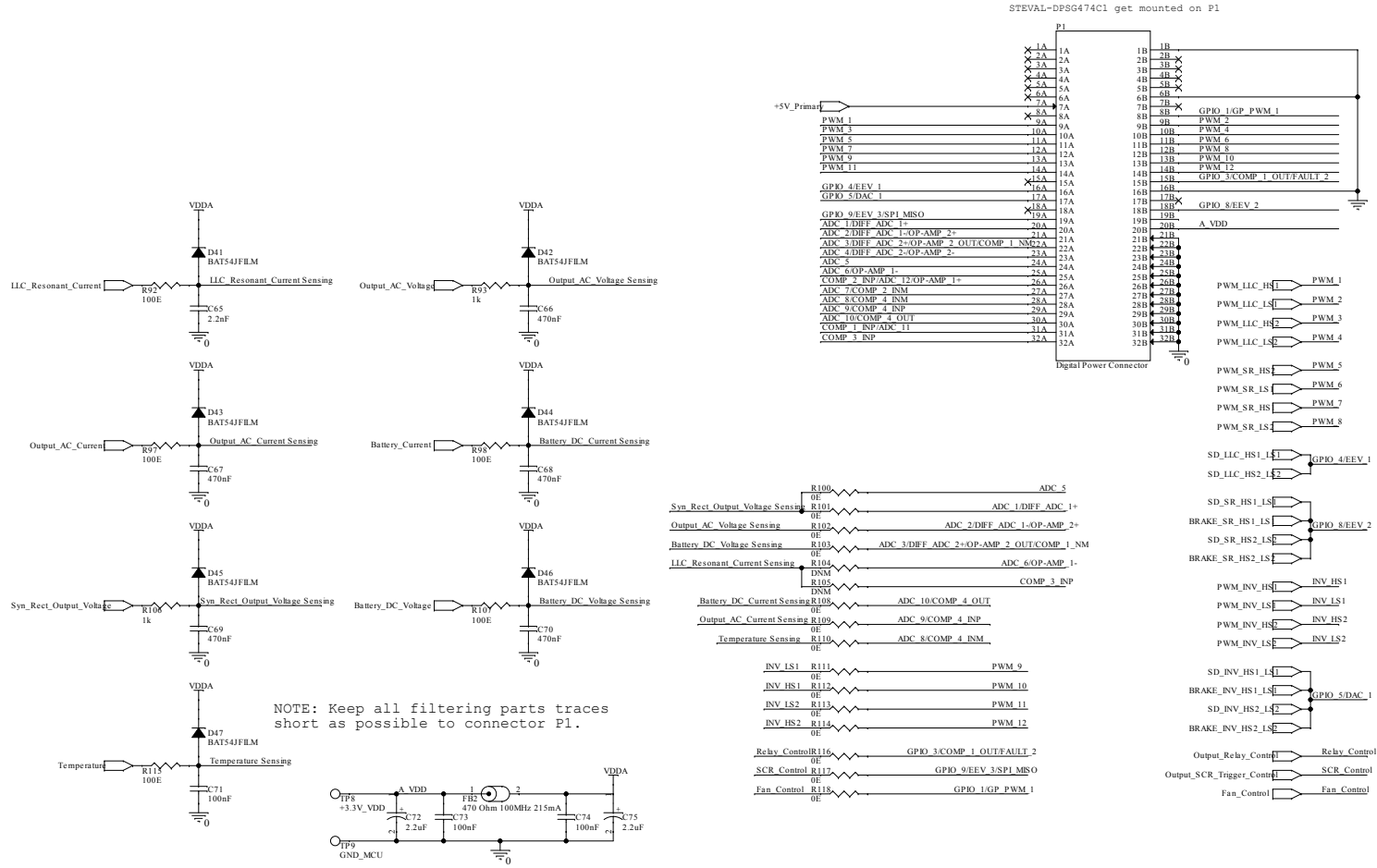

Figure 7. STEVAL-DCAC1KCB: power converter DC-DC - Circuit schematic

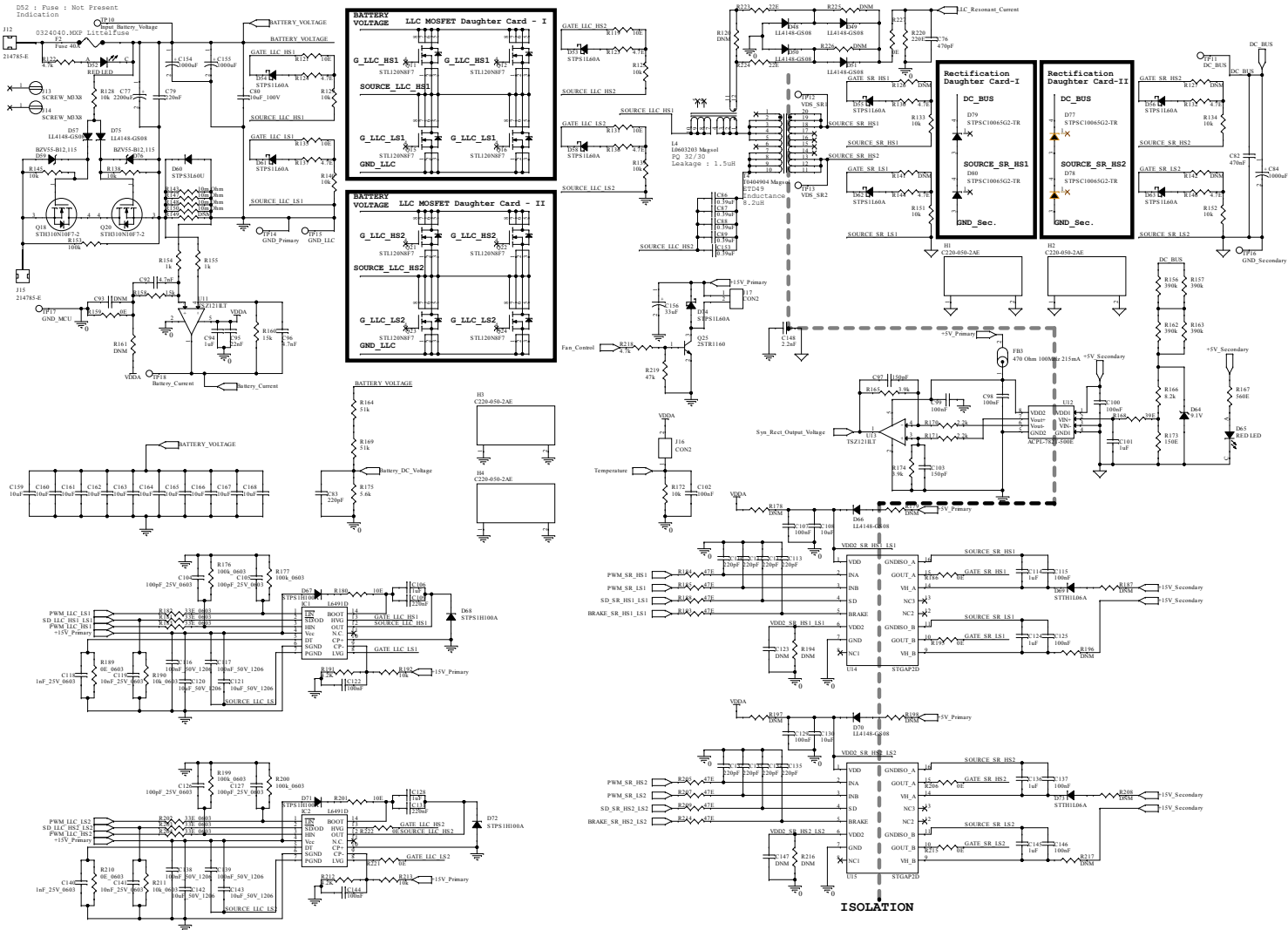

Figure 8. STEVAL-DPSG474: microcontroller card - Circuit schematic (1 of 3)

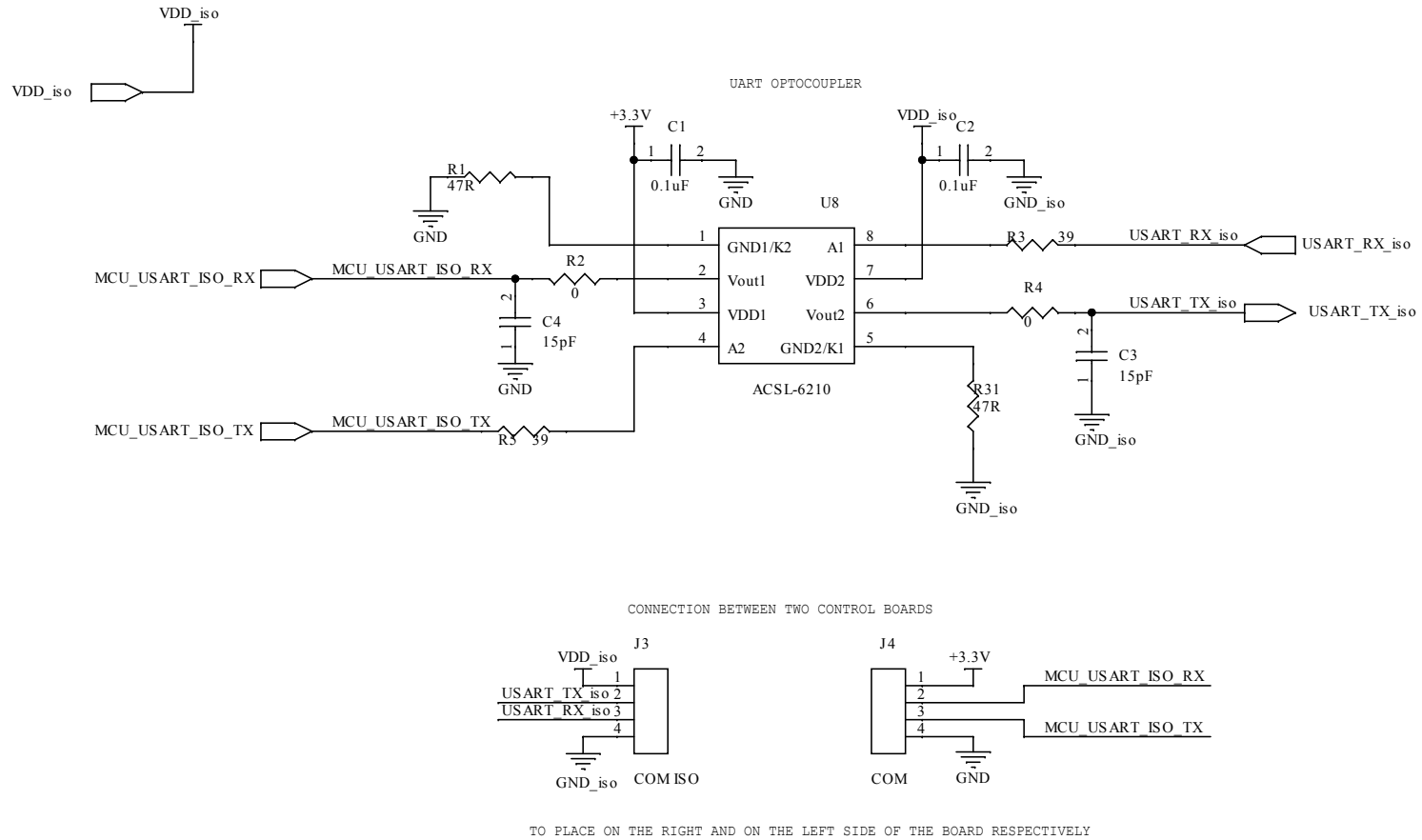

Figure 9. STEVAL-DPSG474: microcontroller card - Circuit schematic (2 of 3)

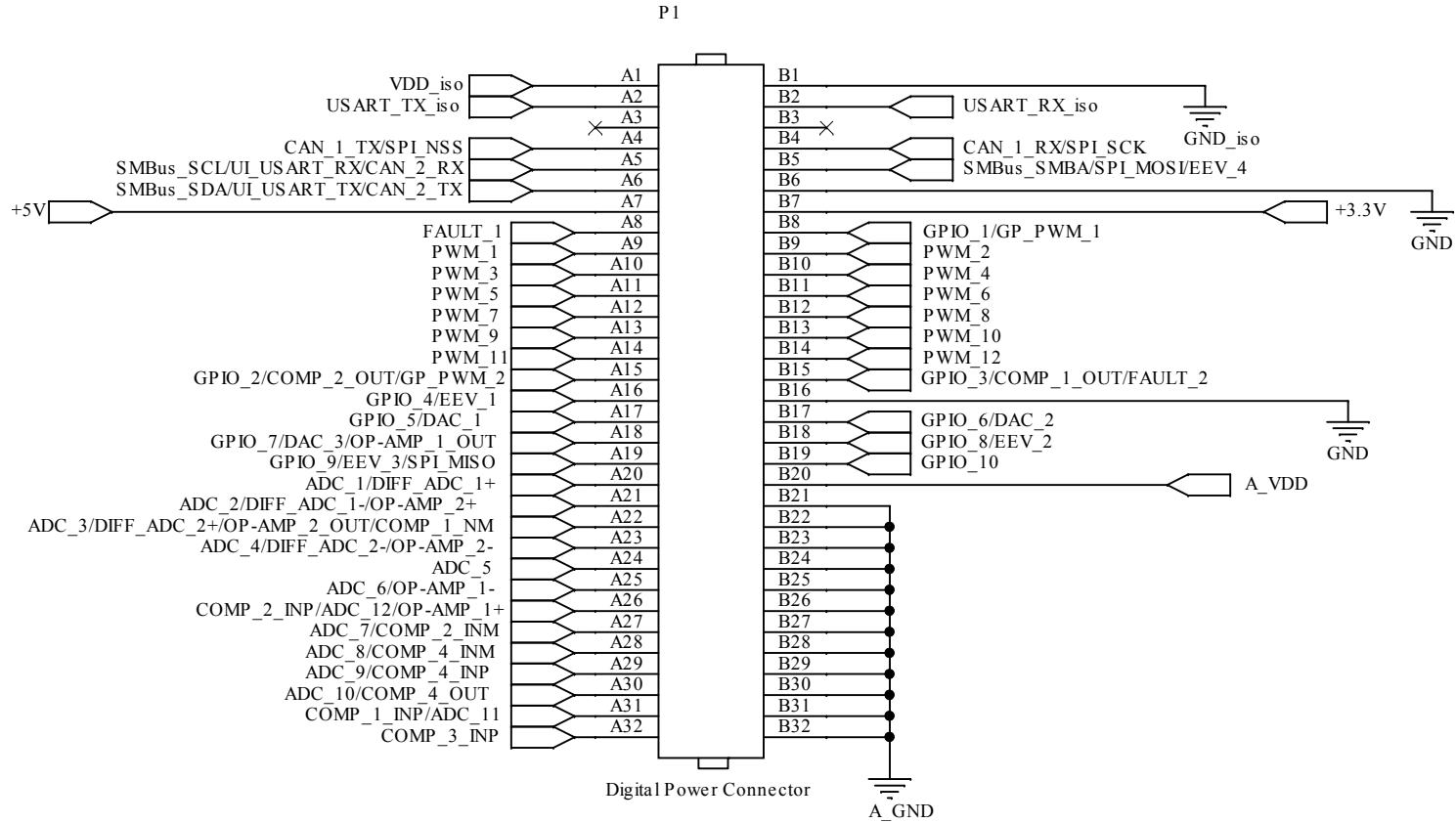
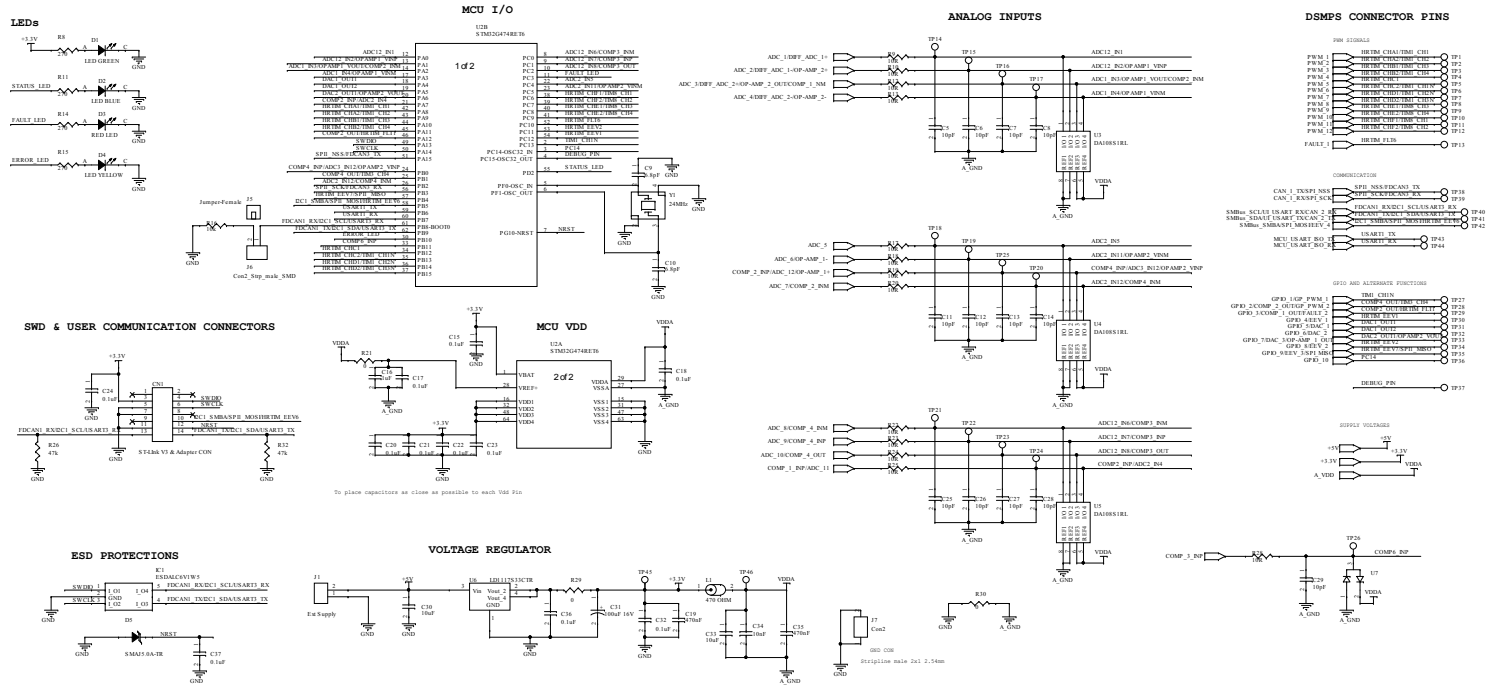

Figure 10. STEVAL-DPSG474: microcontroller card - Circuit schematic (3 of 3)



## **4 Custom evaluation boards information**

---

*Notice: These evaluation boards are custom designed and built, in small quantities, according to specific requests from customers and are destined for evaluation and testing of ST products in a research and development setting. Please contact ST to provide your specific requests and get your custom built board(s).*

## Revision history

**Table 1. Document revision history**

Date	Revision	Changes
05-May-2025	1	Initial release.

**IMPORTANT NOTICE – READ CAREFULLY**

STMicroelectronics NV and its subsidiaries (“ST”) reserve the right to make changes, corrections, enhancements, modifications, and improvements to ST products and/or to this document at any time without notice. Purchasers should obtain the latest relevant information on ST products before placing orders. ST products are sold pursuant to ST’s terms and conditions of sale in place at the time of order acknowledgment.

Purchasers are solely responsible for the choice, selection, and use of ST products and ST assumes no liability for application assistance or the design of purchasers’ products.

No license, express or implied, to any intellectual property right is granted by ST herein.

Resale of ST products with provisions different from the information set forth herein shall void any warranty granted by ST for such product.

ST and the ST logo are trademarks of ST. For additional information about ST trademarks, refer to [www.st.com/trademarks](http://www.st.com/trademarks). All other product or service names are the property of their respective owners.

Information in this document supersedes and replaces information previously supplied in any prior versions of this document.

© 2025 STMicroelectronics – All rights reserved