

Evaluation board for STDRIVEG611 600 V high-speed half-bridge gate driver with SGT120R65AL e-mode GaN HEMT

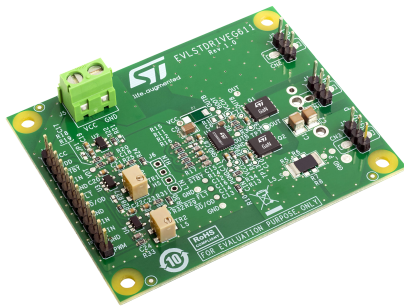

Product status link

[EVLSTDRIVEG611](#)

Features

- Half-bridge topology featuring the STDRIVEG611 GaN gate driver with integrated LDOs, separated sink/source, overcurrent protection, integrated bootstrap diode, standby
- Equipped with 75 mΩ typ., 650 V e-mode HEMT GaN
- Tunable hard-on and hard-off dV/dt, set at 10 V/ns typ. for motor control applications
- 10.6 to 18 V (12 V typ.) VCC supply voltage
- Onboard adjustable deadtime generator to convert a single PWM signal in independent high-side and low-side inputs with deadtime
- Separated inputs with external deadtime can also be used
- Programmable overcurrent protection with SmartShutDown, set at 9.5 A
- Footprint for, optional, additional high-voltage bulk capacitor and bootstrap diode
- Onboard 3.3 V regulator for external circuitry supply
- RoHS compliant.

Description

The **STDRIVEG611** is a high-speed, half-bridge gate driver optimized to drive high-voltage, enhanced mode, GaN HEMTs.

It features separated high current sink/source gate driving pins, integrated LDOs, undervoltage, bootstrap diode, overcurrent protection with SmartShutDown, overtemperature, fault and shutdown pins, and standby to fully support hard switching topologies in a 4x5mm QFN package.

The **EVLSTDRIVEG611** board is easy to use and quick and adapt for evaluating the characteristics of the STDRIVEG611 driving the SGT120R65AL 75 mΩ typ., 650 V E-Mode GaN switches in the 5x6 mm QFN package. The EVLSTDRIVEG611 board is also suitable for evaluating the STDRIVEG211 features.

It provides an onboard programmable deadtime generator and a 3.3 V linear voltage regulator to supply external logic like microcontrollers.

Spare footprints are also included to allow customizing the board for the final application, such as separate LIN and HIN input signals or single PWM signal.

The EVLSTDRIVEG611 is 56 x 70 mm wide, 2 layers, 2 Oz, FR-4 PCB, resulting in 23 °C/W $R_{th(J-A)}$ (equivalent to 46 °C/W for each GaN) in still air to evaluate high power applications.

1 Safety and operating instructions



1.1 General terms

Warning: *During assembly, testing, and operation, the evaluation board poses several inherent hazards, including bare wires, moving or rotating parts, and hot surfaces.*

Danger: *There is a danger of serious personal injury, property damage, or death due to electrical shock and burn hazards if the kit or components are improperly used or installed incorrectly.*

Attention: *The kit is not electrically isolated from the high-voltage supply DC input. No insulation is ensured between the accessible parts and the high voltage. All measuring equipment must use adequately insulated probes, clamps, and connecting wires. Never touch the evaluation board while it is energized as it is capable of causing an electrical shock hazard.*

Important: *All operations involving transportation, installation and use, and maintenance must be performed by skilled technical personnel able to understand and implement national accident prevention regulations. For the purposes of these basic safety instructions, "skilled technical personnel" are suitably qualified people who are familiar with the installation, use, and maintenance of power electronic systems.*

1.2 Intended use of evaluation board

The evaluation board is designed for demonstration purposes only, and must not be used for electrical installations or machinery. Technical data and information concerning the power supply conditions are detailed in the documentation and should be strictly observed.

1.3 Installing the evaluation board

- The installation and cooling of the evaluation board must be in accordance with the specifications and target application.
- The board must be protected against excessive strain. In particular, components should not be bent nor should isolating distances be altered during transportation or handling.
- No contact must be made with other electronic components and contacts.
- The board contains electrostatically sensitive components that are prone to damage if used incorrectly. Do not mechanically damage or destroy the electrical components (potential health risks).

1.4 Operating the evaluation board

To properly operate the board, follow these safety rules.

1. Work area safety:
 - The work area must be clean and tidy.
 - Do not work alone when boards are energized.
 - Protect against inadvertent access to the area where the board is energized using suitable barriers and signs.
 - A system architecture that supplies power to the evaluation board must be equipped with additional control and protective devices in accordance with the applicable safety requirements (that is, compliance with technical equipment and accident prevention rules).
 - Use a non-conductive and stable work surface.
 - Use adequately insulated clamps and wires to attach measurement probes and instruments.
2. Electrical safety:
 - Remove the power supply from the board and electrical loads before taking any electrical measurements.
 - Proceed with the arrangement of measurement setup, wiring, or configuration paying attention to high-voltage sections.
 - Once the setup is complete, energize the board.

Danger: *Do not touch the board when it is energized or immediately after it has been disconnected from the voltage supply as several parts and power terminals containing potentially energized capacitors need time to discharge.
Do not touch the board after disconnection from the voltage supply as several parts, included PCB, may still be very hot.
The kit is not electrically isolated from DC input.*

3. Personal safety
 - Always wear suitable personal protective equipment such as insulating gloves and safety glasses.
 - Take adequate precautions and install the board in such a way to prevent accidental touch. Use protective shields such as, for example, an insulating box with interlocks if necessary.

2 Schematic diagrams

Figure 1. EVLSTDRIVEG611 schematic - STDRIVEG611 gate driver and SGT120R65AL e-mode GaN power stage

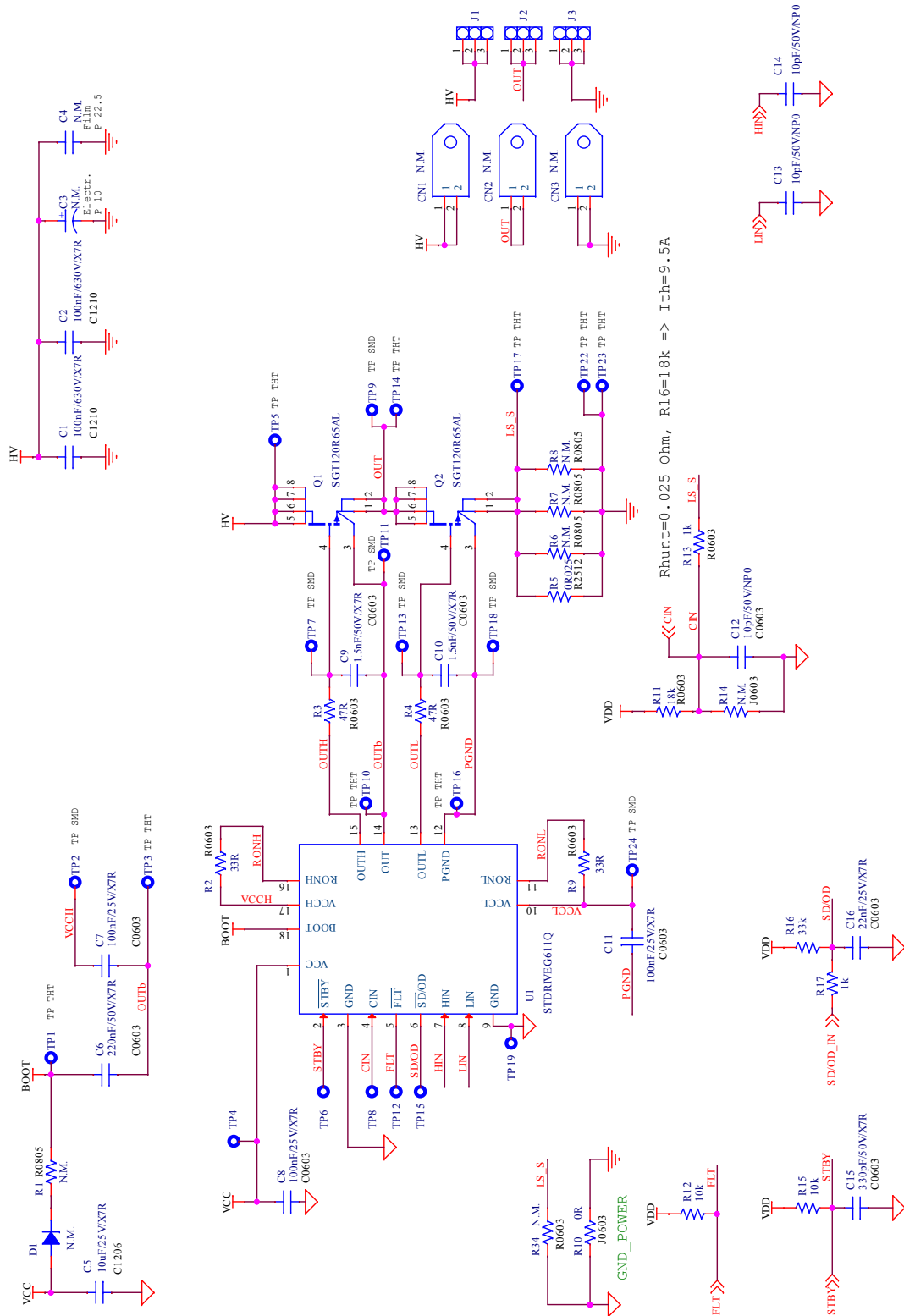
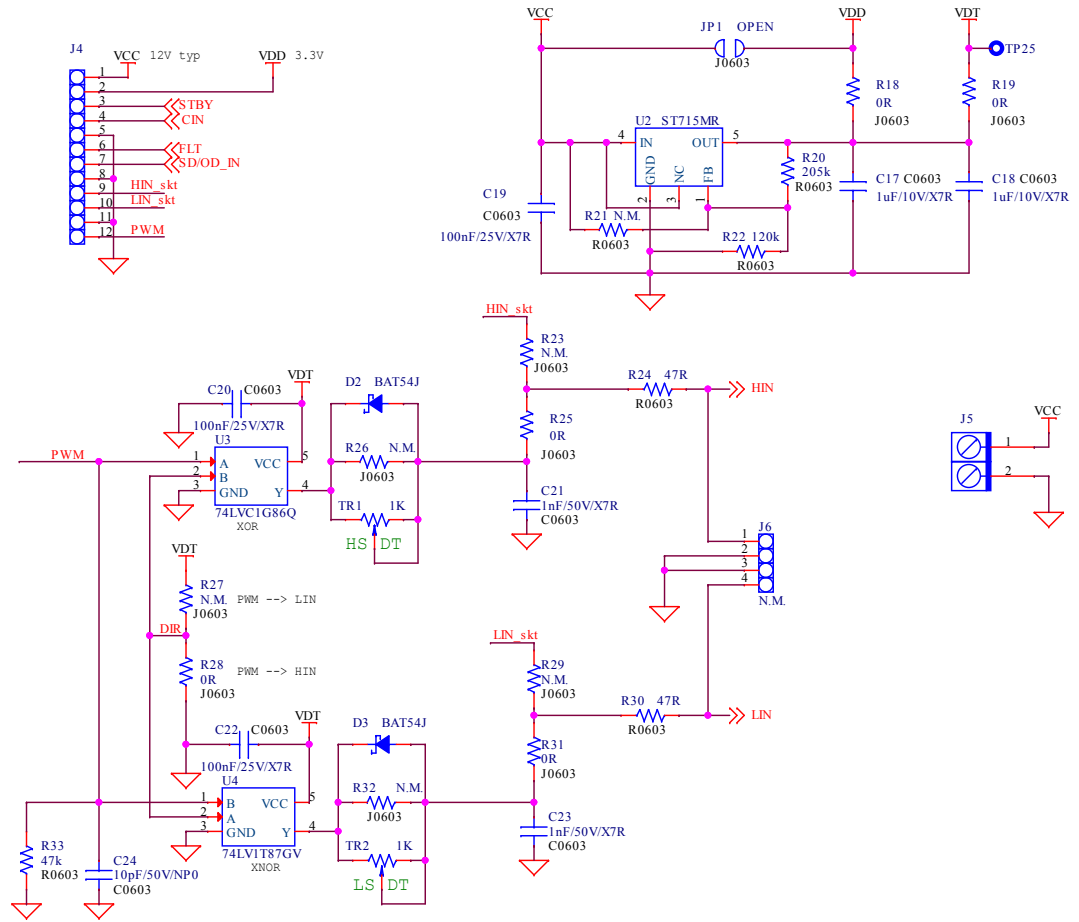

Figure 2. EVLSTDRIVEG611 schematic - deadtime generator and connectors



3 Board power-up and input connection

The following image shows how to supply the EVLSTDRIVEG611, how to provide LIN and HIN inputs and set the programmable deadtime generator.

Figure 3. EVLSTDRIVEG611 - supply and signal connection

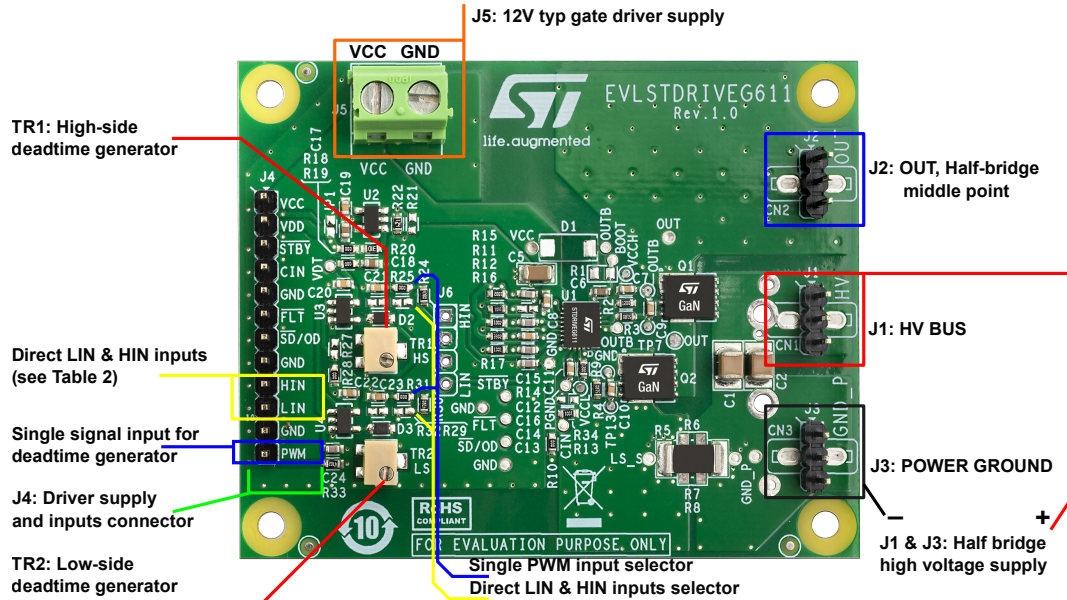

The LIN, HIN inputs can be provided from the onboard deadtime generator or directly from an external generator or control device (such as DSP/MCU).

The deadtime value set by the onboard deadtime generator, fed by PWM input signal on J4, can be tuned by setting TR1 and TR2. The typical deadtime value with the trimmer in the default manufacturing middle position is about 700 ns.

It is possible to change the deadtime generator range by changing C21 and C23. Polarity of PWM input can be modified with R27 and R28 as in Table 3.

TR2 sets the deadtime between high-side turn-off and low-side turn-on.

TR1 sets the deadtime between low-side turn-off and high-side turn-on.

Table 1. Connector map

Ref	Pin #	Name	Function	Description
J4	1	VCC	IN power	Board supply voltage (12 V typ.)
	2	VDD (3V3)	OUT power	Output voltage of onboard 3.3 V (adj.) regulator: it can be used to supply external circuitry (up to about 50 mA)
	3	STBY	IN digital	Standby input signal (active low)
	4	CIN	OUT analog	Low-side current sense resistor voltage
	6	FLT	OUT digital	Fault output (overcurrent, UVLO, overtemperature)
	7	SD/OD	IN digital / OUT analog	Disable input signal (0 to 3.3 V or up to 20 V) – see Table 3. Open-drain output to set the disable time after an overcurrent event (default ~1 ms).
	9	HIN	IN digital	HIN direct input signal (0 to 3.3 V or up to 20 V): mount R23 and remove R25 – see Table 2 and Table 3
	10	LIN	IN digital	LIN direct input signal (0 to 3.3 V or up to 20 V): mount R29 and remove R31 – see Table 2 and Table 3
	12	PWM	IN digital	PWM input signal (0 to 3.3 V or 5 V) – see Table 2 and Table 3

Ref	Pin #	Name	Function	Description
J4	5, 8, 11	GND	Power	Board reference potential
J2	1, 2, 3	OUT	OUT power	These three pins are connected to the OUT pin of the power stage: connect the load to this terminal
J1	1, 2, 3	HV	IN power	These three pins are connected to the high voltage (HV) of the GaN power stage. Connect the half-bridge high-voltage positive supply.
J3	1, 2, 3	GND_P	Power	These three pins are connected to power ground. Connect the half-bridge high-voltage negative supply.
J5	1	VCC	IN power	Board driver supply voltage 12 V typ. (as J4 pin 1)
	2	GND	Power	Board reference potential

Table 2. Device input selection

Board status	Input source	R25, R31	R23, R29	Function and description
Default	PWM J4: pin 12	0 Ω (closed)	Open	LIN & HIN are generated by the onboard deadtime generator from a single PWM signal. PWM input range: 0 to 3.3 V (5 V compatible)
	PWM J4: pin 9, 10	Open	0 Ω (closed)	Direct connection to LIN and HIN STDRIVEG611 pins. LIN, HIN input range: up to 20 V

Table 3. Input signal truth table

Board inputs		PWM polarity	Driver inputs and outputs ⁽¹⁾					
STBY	SD/OD	PWM	R27, R28	LIN	HIN	Low-side	High-side	Half-bridge output
L	X	X	X	X	X	Off	Off	High-Z
X	L							
H (default, pull-up)	H (default, pull-up)	L	R27 open, R28 closed	H	L	On	Off	GND
		H	(default)	L	H	Off	On ⁽²⁾	HV ⁽²⁾
		L	R27 closed, R28 open	L	H	Off	On ⁽²⁾	HV ⁽²⁾
		H		H	L	On	Off	GND

1. With device not in VCC and VCCL UVLO, $CIN < CIN_{th}$ and not in overtemperature.

2. With device not in VCCH UVLO

The recommended power-on sequence is to turn VCC on first, then apply the HV bus voltage. The recommended power-off sequence is to turn off the HV bus supply first, then VCC.

4 Bill of materials

Table 4. EVLSTDRIVEG611 bill of materials

Part reference	Part description	Part value	Package / manufacturer' code
CN1, CN2, CN3	Tab FASTON 250 horizontal	N.M.	
C1, C2	SMT ceramic capacitor	100 nF / 630 V / X7R	Size 1210
C3	THT electrolytic capacitor	N.M.	diam 22 mm, pitch 10 mm
C4	Plastic film capacitor	N.M	pitch 22.5 mm
C5	SMT ceramic capacitor	10 μ F / 25 V / X7R	Size 1206 Würth Elektronik 885012208069 or equivalent
C6	SMT ceramic capacitor	220 nF / 50 V / X7R	Size 0603 Würth Elektronik 885012206125 or equivalent
C7, C8, C11, C19, C20, C22	SMT ceramic capacitor	100 nF / 25 V / X7R	Size 0603 Würth Elektronik 885012206071 or equivalent
C9, C10	SMT ceramic capacitor	1.5 nF / 50 V / X7R	Size 0603 Würth Elektronik 885012206084 or equivalent
C12, C13, C14, C24	SMT ceramic capacitor	10 pF / 50 V / NP0	Size 0805 Würth Elektronik 885012006051 or equivalent
C15	SMT ceramic capacitor	330 pF / 50 V / X7R	Size 0603 Würth Elektronik 885012206080 or equivalent
C16	SMT ceramic capacitor	22 nF / 25 V / X7R	Size 0603 Würth Elektronik 885012206067 or equivalent
C17, C18	SMT ceramic capacitor	1 μ F / 10 V / X7R	Size 0603 Würth Elektronik 885012206026 or equivalent
C21, C23	SMT ceramic capacitor	1 nF / 50 V / X7R	Size 0603 Würth Elektronik 885012206083 or equivalent
D1	Turbo 2 ultrafast high-voltage rectifier	N.M.	SMA
D2, D3	40 V, 300 mA small signal Schottky diode	BAT54J	SOD-323 STMicroelectronics BAT54JFILM or equivalent
JP1	SMT jumper	OPEN	Soldering pads
J1, J2, J3	Strip connector	1x3 pins	Pitch 2.54 mm Würth Elektronik 61300311121 or equivalent
J4	Strip connector	1x12 pins	Pitch 2.54 mm Würth Elektronik 61301211121 or equivalent
J5	Terminal block T.H. 2 pos, 5.08 mm	2 poles	Pitch 5.08 mm Würth Elektronik 691213510002 or equivalent

Part reference	Part description	Part value	Package / manufacturer' code
J6	Strip connector	N.M.	Pitch 2.54 mm Würth Elektronik 61300411121 or equivalent
Q1, Q2	Bottom-side cooled 650 V e-mode GaN transistor	SGT120R65AL	PowerFLAT 5x6 mm HV STMicroelectronics SGT120R65AL
R1, R6, R7, R8	SMT resistor	N.M.	Size 0805
R2, R9	SMT resistor	33 Ω	Size 0603
R3, R4, R24, R30	SMT resistor	47 Ω	Size 0603
R5	SMT resistor	25 mΩ	Size 2512
R10, R18, R19, R25, R28, R31	SMT resistor	0 Ω	Size 0603
R11	SMT resistor	18 kΩ	Size 0603
R12, R15	SMT resistor	10 kΩ	Size 0603
R13, R17	SMT resistor	1 kΩ	Size 0603
R14, R21, R23, R26, R27, R29, R32, R34	SMT resistor	N.M.	Size 0603
R16	SMT resistor	33 kΩ	Size 0603
R20	SMT resistor	205 kΩ	Size 0603
R22	SMT resistor	120 kΩ	Size 0603
R33	SMT resistor	47 kΩ	Size 0603
TP1, TP3, TP4, TP5, TP6, TP8, TP10, TP12, TP14, TP15, TP16, TP17, TP19, TP22, TP23, TP25	Test point for probe	-	Metallized Hole, 0.8 mm diameter
TP2, TP7, TP11, TP13, TP18, TP24	Test point	-	Copper PAD, 1.016 mm diameter
TP9	Test point	-	Copper PAD, 1.27 mm diameter
TR1, TR2	Surface Mount Miniature Trimmers Multi-Turn Cermet Sealed	1 kΩ	Square 5 mm Vishay TSM4YJ
U1	High-voltage, high-speed half-bridge GaN gate driver	STDRIVEG611	QFN18 4x5 mm STMicroelectronics STDRIVEG610Q
U2	High input voltage, 85 mA LDO linear regulator	ST715MR	SOT23-5L STMicroelectronics ST715MR or equivalent
U3	2- inputs EXCLUSIVE-OR gate	74LVC1G86Q	SOT23-5L Diodes incorporated 74LVC1G86QW5-7 or equivalent
U4	2-inputs EXCLUSIVE-NOR gate	74LV1T87GV	SOT23-5L Nexperia 74LV1T87GV or equivalent

5 Layout and component placements

Figure 4. EVLSTDRIVEG611 - layout (component placement top view)

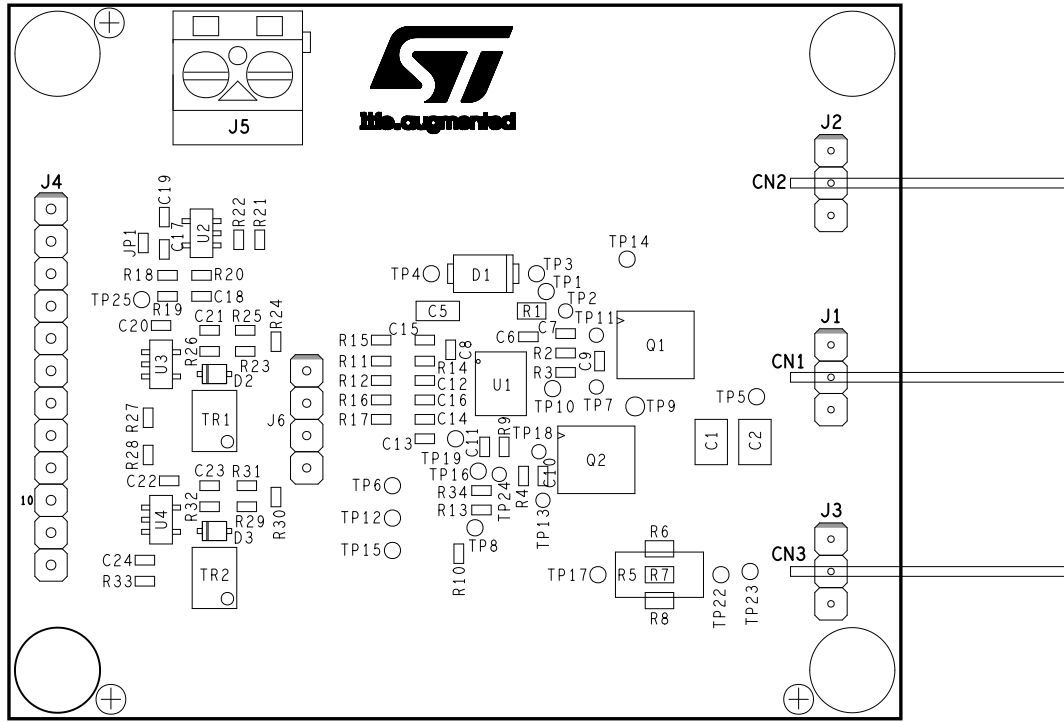

Figure 5. EVLSTDRIVEG611 - layout (component placement bottom view)

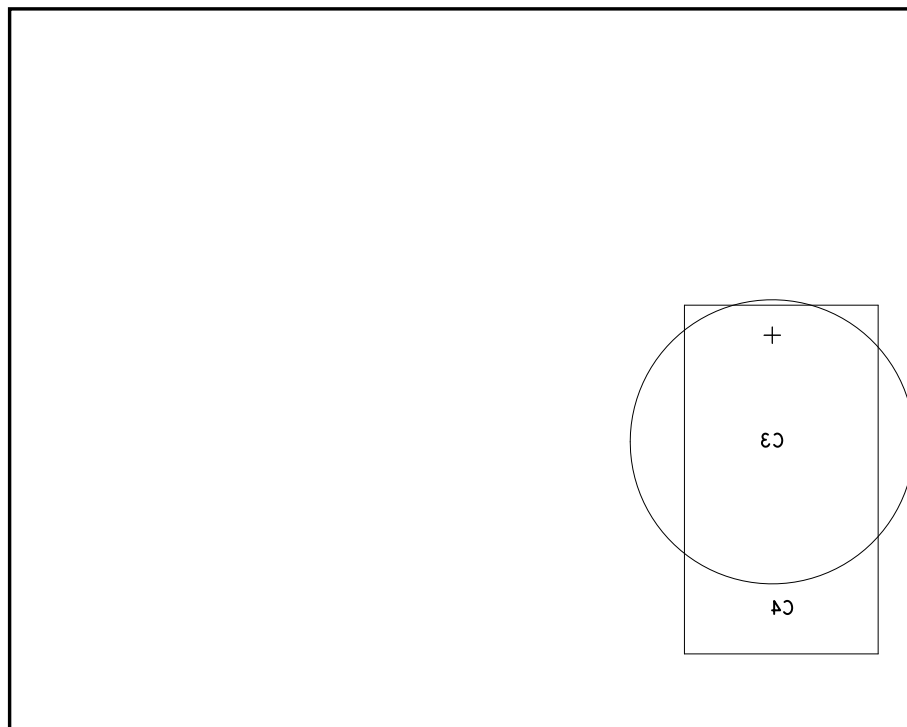

Figure 6. EVLSTDRIVEG611 - layout (top layer)

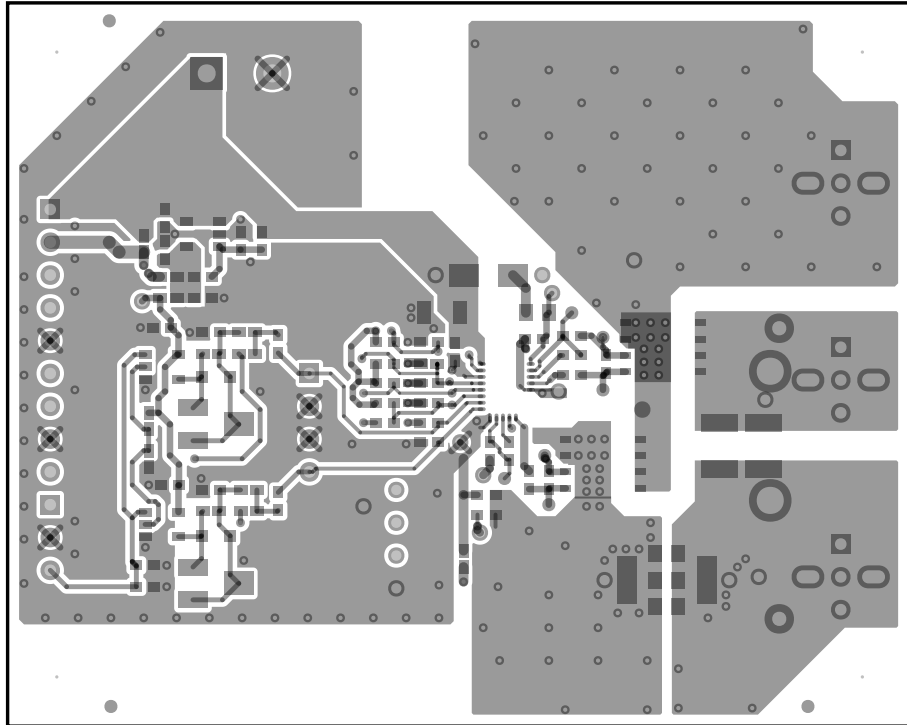
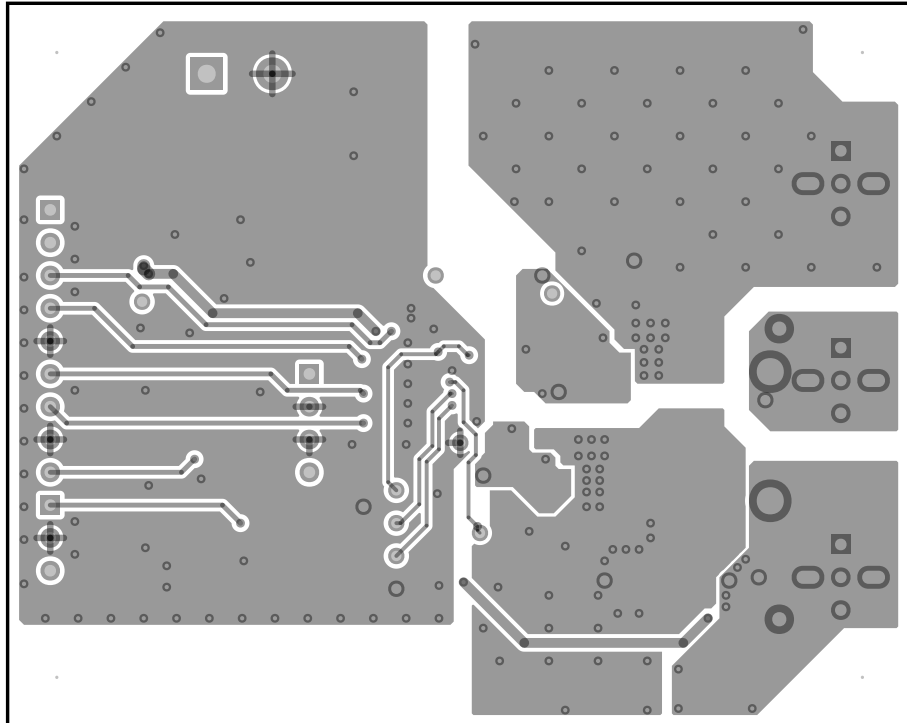

Figure 7. EVLSTDRIVEG611 - layout (bottom layer)



Revision history

Table 5. Document revision history

Date	Version	Changes
03-Sep-2024	1	Initial release.
25-Jun-2025	2	Updated Section Description .

Contents

1	Safety and operating instructions	2
1.1	General terms	2
1.2	Intended use of evaluation board	2
1.3	Installing the evaluation board	2
1.4	Operating the evaluation board	3
2	Schematic diagrams	4
3	Board power-up and input connection	6
4	Bill of materials	8
5	Layout and component placements	10
	Revision history	12
	List of tables	14
	List of figures	15



List of tables

Table 1.	Connector map	6
Table 2.	Device input selection.	7
Table 3.	Input signal truth table	7
Table 4.	EVLSTDRIVEG611 bill of materials	8
Table 5.	Document revision history	12

List of figures

Figure 1.	EVLSTDRIVEG611 schematic - STDRIVEG611 gate driver and SGT120R65AL e-mode GaN power stage	4
Figure 2.	EVLSTDRIVEG611 schematic - deadtime generator and connectors	5
Figure 3.	EVLSTDRIVEG611 - supply and signal connection	6
Figure 4.	EVLSTDRIVEG611 - layout (component placement top view)	10
Figure 5.	EVLSTDRIVEG611 - layout (component placement bottom view)	10
Figure 6.	EVLSTDRIVEG611 - layout (top layer)	11
Figure 7.	EVLSTDRIVEG611 - layout (bottom layer)	11

IMPORTANT NOTICE – READ CAREFULLY

STMicroelectronics NV and its subsidiaries (“ST”) reserve the right to make changes, corrections, enhancements, modifications, and improvements to ST products and/or to this document at any time without notice. Purchasers should obtain the latest relevant information on ST products before placing orders. ST products are sold pursuant to ST’s terms and conditions of sale in place at the time of order acknowledgment.

Purchasers are solely responsible for the choice, selection, and use of ST products and ST assumes no liability for application assistance or the design of purchasers’ products.

No license, express or implied, to any intellectual property right is granted by ST herein.

Resale of ST products with provisions different from the information set forth herein shall void any warranty granted by ST for such product.

ST and the ST logo are trademarks of ST. For additional information about ST trademarks, refer to www.st.com/trademarks. All other product or service names are the property of their respective owners.

Information in this document supersedes and replaces information previously supplied in any prior versions of this document.

© 2025 STMicroelectronics – All rights reserved