

Designing for Economical Cost and Low Power Magnetic Switching



Scott Bryson

ABSTRACT

To extend the operating life and improve user experience, many applications are adopting magnetic switches to eliminate the use of mechanical contact switches, which are prone to failure over time due to mechanical wear, oxidation, and the buildup of contaminants on the contact surface. In many applications such as home appliances, locks, door and window controls, and flow meters there is importance to keep total power consumption to a minimum to maintain power efficiency. Although mechanical switches offer the benefit of zero power consumption when the circuit is open, the switches have long-term reliability challenges. Magnetic designs including reed switches, Hall-effect sensors, and Tunneling Magneto Resistive Sensors are commonly used as low power alternatives with better reliability.

Table of Contents

1 Introduction	1
1.1 Reed Switches.....	1
1.2 Hall-Effect Sensors.....	3
1.3 Tunneling Magneto Resistance (TMR) Sensors.....	5
2 Design Considerations	6
2.1 Technology Complexity and Cost.....	6
2.2 Axis of Sensitivity.....	6
2.3 Mechanical Constraints.....	7
2.4 Power Consumption.....	8
3 Summary	8
4 References	9
5 Revision History	10

Trademarks

All trademarks are the property of their respective owners.

1 Introduction

Reed Switches, Hall-effect sensors, and Tunneling Magnetor Resistive (TMR) sensors are all practical options that increase system reliability, and each technology operates under somewhat different principles. We can briefly introduce the technologies, then compare each in terms of design complexity, mechanical constraints, and power consumption to examine the benefits and challenges related to each magnetic switch technology.

1.1 Reed Switches

Of the three technologies previously mentioned (reed switches, Hall-effect sensors, and TMR sensors), only reed switches are a zero power design.

Reed switches are normally constructed with two or three metal contacts made out of a ferromagnetic material shown in [Figure 1-1](#). A reed switch with two metal contacts has a single contact point that closes when a sufficiently strong magnetic field is present while a three contact reed switch can have a common pin that switches between two paths depending on the magnet presence. For both cases, these contacts can have a normally closed or open position that is determined by the reed switch manufacturer.

Reed switches are also hermetically sealed at vacuum or filled with inert gas to prevent the build-up of contaminants or surface oxidation that can otherwise increase contact resistance or possibly even completely block electrical contact.



Figure 1-1. Typical Reed Switch

A common use of the reed switch is to embed the switch behind a surface which is magnetically permeable and to control the switch through the interaction with a nearby magnetic field. Instead of placing a mechanical striker plate on the moving target, all that is needed is a permanent magnet that can move into the vicinity of the reed switch.

The reeds themselves are made from a ferromagnetic material which can channel the magnetic field. When placed correctly, the magnetic field can channel between both reeds which causes a small torque to be applied on each. This forces the two reeds towards each other and closes the electrical circuit. Notice in [Figure 1-2](#) the concentrated magnetic flux density that results between the tips of the two reeds when a magnet is present.

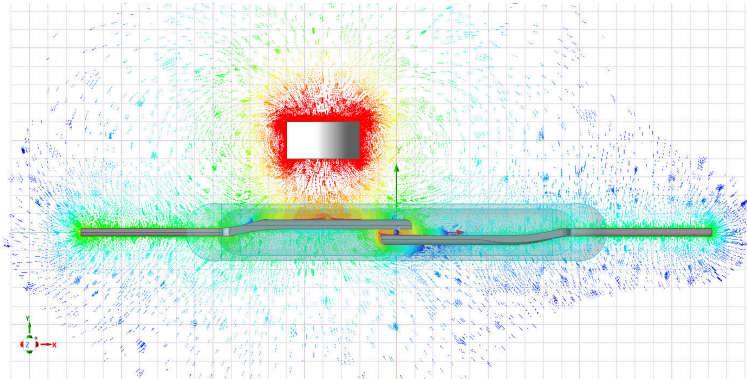

Figure 1-2. Reed Switch Simulated Response

The specific placement and orientation of the magnet required to close the reed switch can vary based on the construction of the device. The resulting field between the two reeds must be strong enough to cause them to flex towards each other. When the magnet is placed too far from the junction, there is a possibility that the field cannot channel adequately through both reeds. Creating a horizontal offset of the magnet position reduces the magnitude of the concentrated field between the reeds in [Figure 1-3](#).

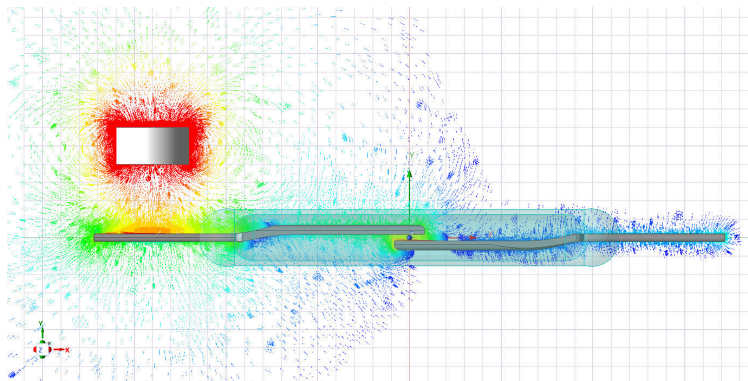

Figure 1-3. Reed Switch Offset Simulation

A sensitivity diagram can be provided by the reed switch manufacturer which must be followed to properly place the magnet for any switching application.

1.2 Hall-Effect Sensors

The Hall-effect was discovered by Edwin Hall. Hall discovered that when a current is passed through a conductor that has a magnetic field applied orthogonally, that the Lorentz force can cause a measurable voltage potential across the conductor.

The Lorentz force arises from a charged particle moving through an electromagnetic field as shown in [Figure 1-4](#) and described in [Equation 1](#).

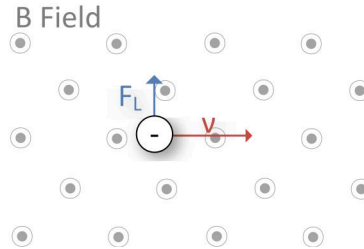

Figure 1-4. Lorentz Force

$$\vec{F}_L = q (\vec{E} + \vec{v} \times \vec{B}) \quad (1)$$

Considering this behavior when driving a current through a magnetic field, we observe the Hall-effect as shown in [Figure 1-5](#).

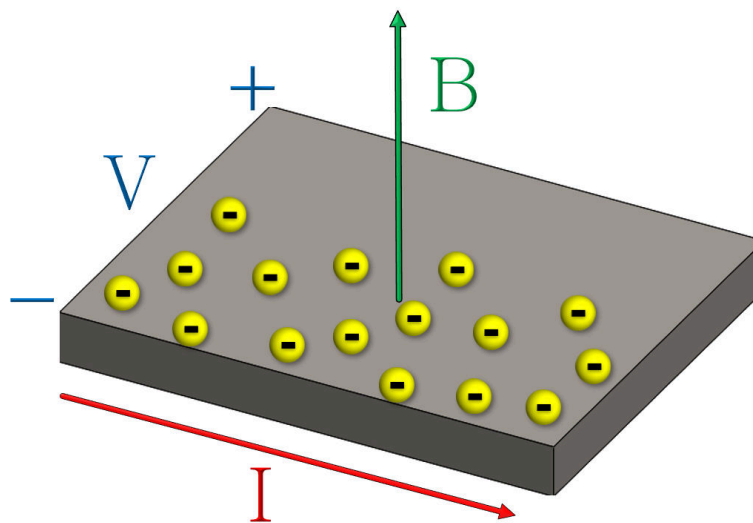

Figure 1-5. Hall-effect

When a conductive Hall-element is biased with a current and placed in a magnetic field, there is a linear change in the voltage which is produced across the conductor orthogonal to the current. This is particularly useful in generating a number of output formats that aid in tracking the position of a source magnet.

Of particular note here is the switch format. When amplified and driven into a comparator structure like that in [Figure 1-6](#), this voltage can be used to produce a binary output response demonstrated in [Figure 1-7](#). The device can be set to target a variety of operate and release thresholds (commonly referred to a B_{OP} and B_{RP} respectively), and can be set to sample at various intervals to limit current consumption.

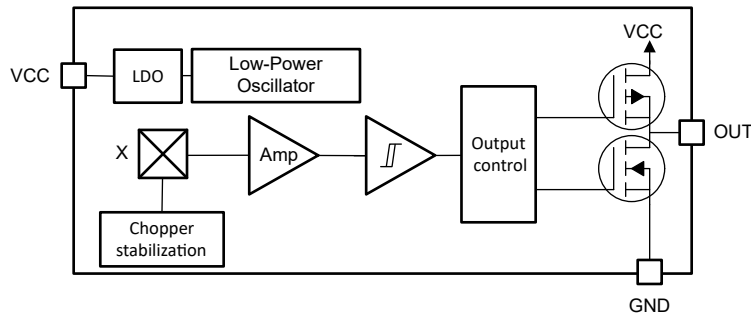

Figure 1-6. TMAG5233 Block Diagram

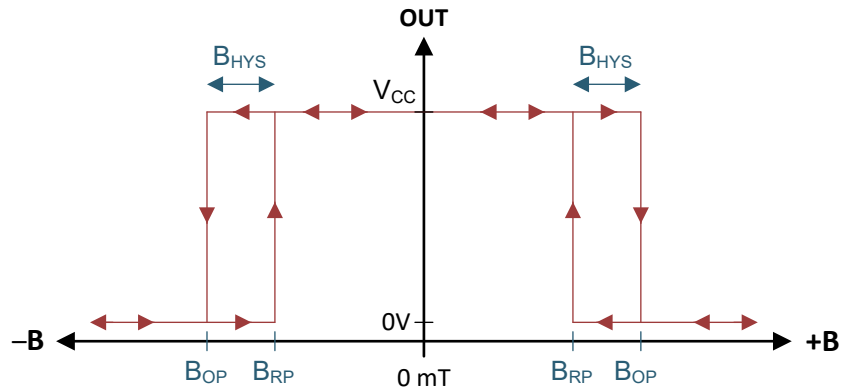

Figure 1-7. Omnipolar Switch Output

This technology is easily integrated into semiconductor processes. Traditionally, the Hall-element has been constructed with a sensitivity which is normal to the PCB surface and detect the Z-component of the B-Field vector similar to [Figure 1-8](#), but newer devices are also able to implement in-plane sensing elements which detect a horizontal vector component in either the X or Y directions. This sensitivity is shown in [Figure 1-9](#).

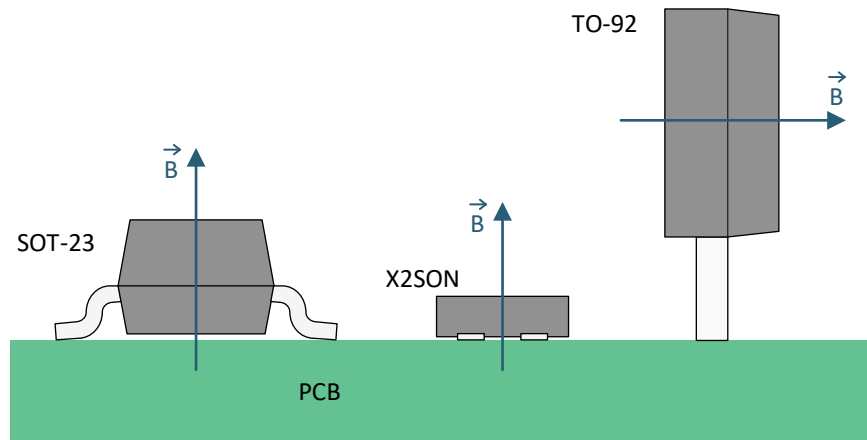

Figure 1-8. DRV5032 Vertical Sensitivity

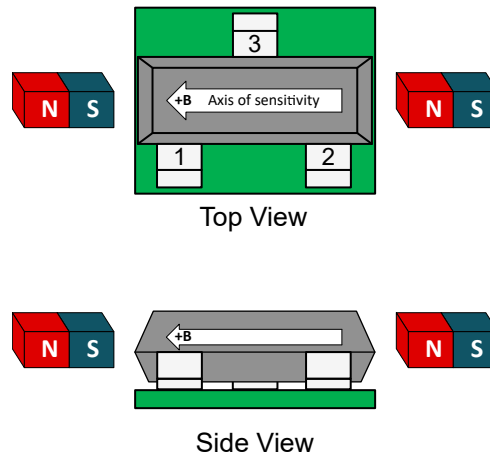

Figure 1-9. TMA5233 In-plane Sensitivity

1.3 Tunneling Magneto Resistance (TMR) Sensors

With the advancement in material science and quantum mechanics, a newer technology is now being adapted into magnetic switches that takes advantage of electron tunneling that can occur between magnetic structures which are separated by an ultra-thin dielectric layer.

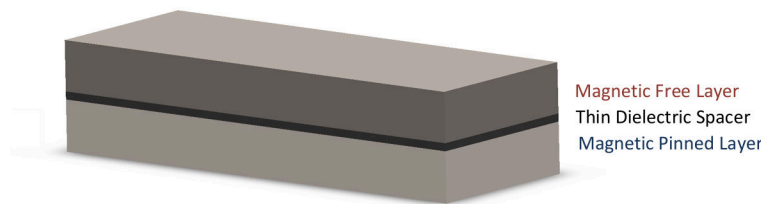

Figure 1-10. Simplified TMR Stack-up

The top and bottom blocks shown in Figure 1-10 are actually a complex layering of conductive magnetic materials which are able to produce the TMR effect. During fabrication, the bottom layer has had a specific magnetization applied and is commonly referred to as the pinned layer. Also, the top layer is considered to be free.

When an applied magnetic field is introduced to the structure the overall resistance of the material can vary based on the relative direction of the field. When the applied magnetic vector is parallel to the magnetization of the substrate layer, then the relative impedance can be at the maximum, but as the applied field approaches the anti-parallel direction to the flow of current, then the impedance can drop to a minimum shown in Figure 1-11.

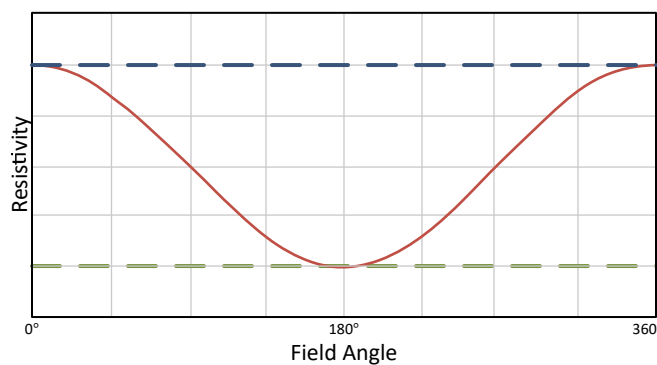

Figure 1-11. TMR Impedance Diagram

As a result of the normal fabrication processes for this technology, TMR sensors are typically constructed so that the sensors are sensitive to the field applied within the XY plane.

2 Design Considerations

Now that the basic operation of each technology has been discussed, the question stands how best to consider each in practical design. In practice, the mechanical robustness of the design, sensitivity of the sensor, overall cost, and power consumption can be key deciding factors

2.1 Technology Complexity and Cost

The complexity to create any switching technology has a direct impact on the size and cost of the sensor.

Hall-effect sensors can be miniaturized and are easily integrated in modern semiconductor processes. As a result these devices are typically manufactured and marketed at lower costs than either TMR or reed switches.

Reed switches are enclosed in a glass tube or some other hermetically sealed enclosure, and this process produces larger and costlier packaging requirements. These enclosures can be fragile which also increases handling and installation costs with an increased risk that these devices can need to be replaced in time due to physical damage.

The complex stack of materials involved with the creation of TMR sensors requires specialized deposition equipment not common to all semiconductor manufacturing flows and require an added step of magnetizing the pinned layer. The increased process steps and specialized materials make TMR inherently more expensive than Hall-effect sensors. Low-power Hall-effect sensors like [TMAG5233](#) and [TMAG5133](#) can be a more pragmatic choice.

2.2 Axis of Sensitivity

Considering the method of construction of each sensor type the direction of sensitivity to activate the switching function can limit the alignment of the sensor to the input magnetic field.

2.2.1 Hall-Effect Switches

Hall-effect sensors are the most flexible option. With the ability to sense any magnetic field component, the sensors can be configured and installed to detect any magnetic field stronger than B_{OP} . Small surface mount package sizes available with this sensing technology allow for extremely flexible placement. These devices are easily connected over longer wires to be embedded behind target surfaces, or can easily fit into controller PCBs using either vertical or horizontal (In-plane) sensitivity; see [Figure 2-1](#).

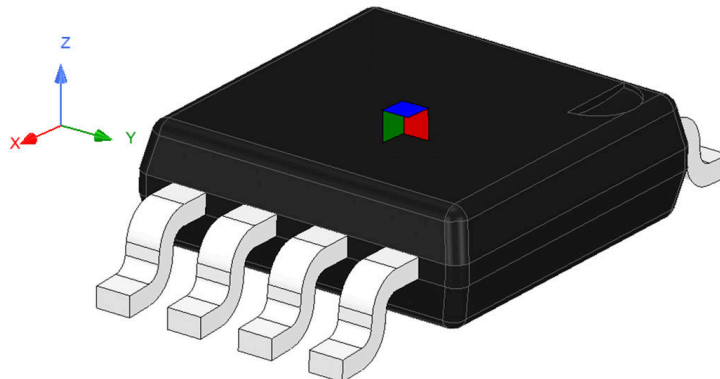

Figure 2-1. Hall-Effect Sensitivity

2.2.2 TMR Switches

TMR switches are typically built in such a way that the switches are predominantly sensitive in the XY plane. In most cases these devices are considered in-plane sensors, and require presenting the magnet as shown in [Section 1.3](#).

2.2.3 Reed Switches

Reed switches sensitivity can rely on how the magnetic field interacts with the ferromagnetic structures in the switch. The field must be channeled strongly enough between the two reeds to cause them to flex. In some cases, there is a possibility that there can be zones where a reed switch is not sensitive to the presence of the magnet, but can be activated after rotating the magnet 90°.

These devices do often support a wide selection of arrangements, but can have multiple trip points depending on the magnet motion and are more difficult to place and install due to the device size.

2.3 Mechanical Constraints

The overall sensitivity of the switch controls the range of the input magnet required for the sensor. Typically, each switching technology can be configured with operating thresholds (B_{OP}) that are less than 5mT. The total range required for a specific magnet can be determined using simulation tools like the [TI Magnetic Sense Simulator](#).

Electron tunneling in TMR sensors achieves the highest magnetic sensitivity available by magnetic sensors and can be configured for omnipolar operation similar to Hall-effect sensors. That is, that the switch can operate regardless of which magnetic pole is presented to the sensor. This is often useful during product assembly to reduce effort needed to align the magnet. However, there are functions that call for distinguishing which pole has been presented, and in these cases a unipolar switch can be needed as shown in [Figure 2-2](#).

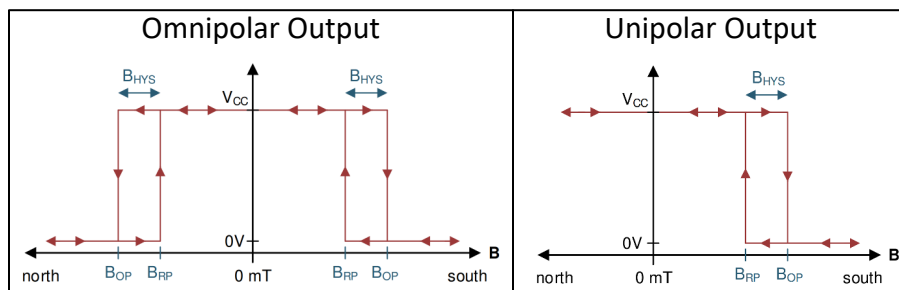

Figure 2-2. Magnetic Switch Output Modes

Hall-effect sensors offer the same functionality with the benefit of versatility in sensing direction, but offer greater flexibility in magnet positioning than TMR sensors. A particular concern that must be considered when using a TMR sensor is that the input magnetic field must always remain below the upper maximum input magnetic field rating. Since the pinned layer of the device is magnetized with a specific polarity, introduction of a significantly strong magnetic field can cause irreparable damage to the sensor. TMR magnetic over-exposure can manifest in the form of offset or even a change in the overall sensitivity of the device. Hall-effect sensors are not subject to this risk, and therefore can be placed as close to the magnet as desired.

In all cases, the input magnetic field must vary in such a way that the maximum input can always exceed the maximum rated value for B_{OP} and that the minimum field when the magnet is withdrawn is less than the minimum rated value for B_{RP} . This helps to eliminate risk that a device with an edge condition functions abnormally. In the case of reed switches, the actual construction of the switch can create zones of operation that result from how the individual reeds channel the magnetic field. This can include the possibility of inadvertent switching zones that are harder to predict without guidance from the manufacturer.

Another challenge to consider when designing with reed switches is that they can experience debounce, which is the result of an elastic collision where the two reeds separate after coming into contact with each other. The debounce extends the settling time of the signal, and can affect transmission integrity if not handled appropriately. The opening and closing of these mechanical contacts can also cause wear and tear over time leading to an eventual failure in the switching mechanism. The amount of switching cycles that it takes to break a reed switch depends on the construction and the load applied to the switch. For higher loads, this breaking point can be between 100,000 and 1,000,000 switch cycles.

A final mechanical consideration with reed switches is that the switches construction prohibits them from being handled as easily as packaged Hall-effect or TMR sensors. In many cases, the enclosure prohibits surface

mount installation using standard assembly procedures with a pick and place machine and solder reflow. Care must be taken to not damage the enclosure during the assembly process.

2.4 Power Consumption

Despite the mechanical limitations, the reed switch does achieve the designed for goal of zero power consumption since the operation is driven through the introduction of a permanent magnet and the subsequent electromagnetic force which pulls the reeds together.

Hall-effect and TMR sensors both require a bias current through the sensing element which is then influenced through the Lorentz force (Hall-effect) or quantum tunneling (TMR). The TMR sensor is typically higher impedance than the Hall-effect sensor, which results with lower current with the same applied input voltage. As a result, TMR sensors often achieve average operating currents at 1 μ A or better.

Hall-effect sensors can still compete with TMR in many battery powered applications, however. The typical operating behavior for both sensors is to periodically sample the sensor with the required active bias current. Between samples, the sensor is put into a low-power state for a predetermined period of time. While in this low-power state, the Hall-effect sensor can consume minimal power.

For instance, in the case of [TMAG5233](#) and [TMAG5133](#), these devices are well designed for low-power switching applications such as monitoring interactions with human machine interfaces (HMI). In these cases, data refresh rates can remain very low to reduce the total active time for the sensing element. To minimize average current to the [TMAG5233](#), a sample rate of 5Hz is offered to allow for typical operating currents of approximately 0.55 μ A. For the [TMAG5133](#), a sample rate of 20Hz is offered to allow for typical operating currents of approximately 1.8 μ A.

3 Summary

Advancements in sensing technologies are providing low-power devices that increase the overall system reliability. Hall-effect sensors such as [TMAG5233](#) and [TMAG5133](#) offer low-power magnetic detection at lower manufacturing costs than TMR and at comparable sensitivity thresholds.

Table 3-1. Technology Comparison

Parameter	Hall-effect	TMR	Reed Switch
Cost	Lowest	High	Highest
Sensing Direction	Vertical or in-plane (X,Y,Z)	Typically in-plane (X,Y)	Vertical or in-plane depending on construction
Handling	Standard PCB assembly	Standard PCB assembly	Typically require manual installation
Current Consumption	As low as 0.55 μ A	<0.3 μ A	Zero Current
Typical Operating Threshold (B_{OP})	As low as 1.8mT	As low as 0.3mT	<5mT
Permanent Damage from strong fields	None	Some devices can be damaged with fields as low as 100mT	Uncommon

To further explore low-power and in-plane magnetic switch options, please consider [Table 3-2](#).

Table 3-2. Related Devices

Device	Grade	Sensitivity Direction	Package Options	Average Current (μ A)
TMAG5233	Commercial	In-plane	SOT23-3(DBV)	2.7 μ A (40Hz) 0.55 μ A (5Hz)
TMAG5133	Commercial	In-plane	X1LGA (ZFC)	2.7 μ A (40Hz) 1.8 μ A (20Hz)
DRV5032	Commercial	Vertical	SOT23-3(DBV) TO-92(LPG) X2SON(DMR)	5.7 μ A (80Hz) 1.6 μ A (20Hz) 0.69 μ A (5Hz)
TMAG5231	Commercial	Vertical	SOT23-3(DBV) X2SON (DMR)	16 μ A (216Hz) 2 μ A (20Hz) 1.3 μ A (10Hz)
TMAG5123 (Q1)	Commercial (Automotive)	In-plane	SOT23-3 (DBV)	3.5mA (10kHz)

4 References

1. Flair Electronics, [Magnetic Reed Switch Principals of Operation](#).
2. Texas Instruments, [Intro to 3D Hall-effect Sensors](#), video.
3. [Magnetic Force](#).
4. Electronic Design, [What's the Difference Between TMR and GMR Sensors?](#).

5 Revision History

Changes from Revision * (September 2024) to Revision A (June 2025)	Page
• Updated the numbering format for tables, figures, and cross-references throughout the document	1
• Added TMAG5133 reference throughout document.....	1

IMPORTANT NOTICE AND DISCLAIMER

TI PROVIDES TECHNICAL AND RELIABILITY DATA (INCLUDING DATA SHEETS), DESIGN RESOURCES (INCLUDING REFERENCE DESIGNS), APPLICATION OR OTHER DESIGN ADVICE, WEB TOOLS, SAFETY INFORMATION, AND OTHER RESOURCES "AS IS" AND WITH ALL FAULTS, AND DISCLAIMS ALL WARRANTIES, EXPRESS AND IMPLIED, INCLUDING WITHOUT LIMITATION ANY IMPLIED WARRANTIES OF MERCHANTABILITY, FITNESS FOR A PARTICULAR PURPOSE OR NON-INFRINGEMENT OF THIRD PARTY INTELLECTUAL PROPERTY RIGHTS.

These resources are intended for skilled developers designing with TI products. You are solely responsible for (1) selecting the appropriate TI products for your application, (2) designing, validating and testing your application, and (3) ensuring your application meets applicable standards, and any other safety, security, regulatory or other requirements.

These resources are subject to change without notice. TI grants you permission to use these resources only for development of an application that uses the TI products described in the resource. Other reproduction and display of these resources is prohibited. No license is granted to any other TI intellectual property right or to any third party intellectual property right. TI disclaims responsibility for, and you will fully indemnify TI and its representatives against, any claims, damages, costs, losses, and liabilities arising out of your use of these resources.

TI's products are provided subject to [TI's Terms of Sale](#) or other applicable terms available either on [ti.com](https://www.ti.com) or provided in conjunction with such TI products. TI's provision of these resources does not expand or otherwise alter TI's applicable warranties or warranty disclaimers for TI products.

TI objects to and rejects any additional or different terms you may have proposed.

Mailing Address: Texas Instruments, Post Office Box 655303, Dallas, Texas 75265

Copyright © 2025, Texas Instruments Incorporated