

SN54ALS240A, SN54AS240A, SN74ALS240A, SN74AS240A OCTAL BUFFERS/DRIVERS WITH 3-STATE OUTPUTS

SDAS214E – DECEMBER 1982 – REVISED AUGUST 2002

- 3-State Outputs Drive Bus Lines or Buffer Memory Address Registers
- pnp Inputs Reduce dc Loading

SN54ALS240A, SN54AS240A . . . J OR W PACKAGE
SN74ALS240A . . . DB, DW, N, OR NS PACKAGE
SN74AS240A . . . DW OR N PACKAGE
(TOP VIEW)

description/ordering information

These octal buffers/drivers are designed specifically to improve both the performance and density of 3-state memory address drivers, clock drivers, and bus-oriented receivers and transmitters. When these devices are used with the 'ALS241, 'AS241A, 'ALS244, and 'AS244A devices, the circuit designer has a choice of selected combinations of inverting and noninverting outputs, symmetrical active-low output-enable (\overline{OE}) inputs, and complementary OE and \overline{OE} inputs. These devices feature high fan-out and improved fan-in.

The -1 version of SN74ALS240A is identical to the standard version, except that the recommended maximum I_{OL} for the -1 version is 48 mA. There is no -1 version of the SN54ALS240A.

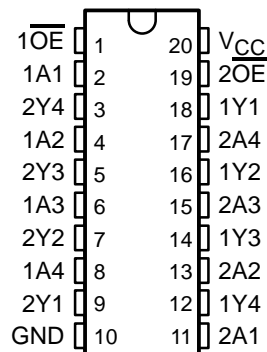

SN54ALS240A, SN54AS240A . . . FK PACKAGE
(TOP VIEW)

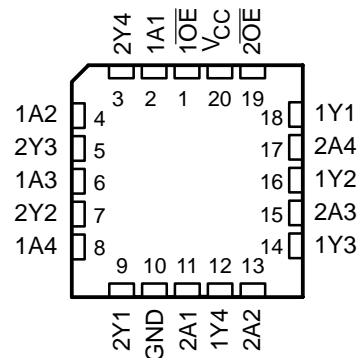

ORDERING INFORMATION

T_A	PACKAGE†		ORDERABLE PART NUMBER	TOP-SIDE MARKING
0°C to 70°C	PDIP – N	Tube	SN74ALS240AN	SN74ALS240AN
			SN74ALS240A-1N	SN74ALS240A-1N
			SN74AS240AN	SN74AS240AN
	SOIC – DW	Tube	SN74ALS240ADW	ALS240A
			SN74ALS240ADWR	
		Tape and reel	SN74ALS240A-1DW	ALS240A-1
			SN74ALS240A-1DWR	
		Tube	SN74AS240ADW	AS240A
			SN74AS240ADWR	
	SOP – NS	Tape and reel	SN74ALS240ANSR	ALS240A
			SN74ALS240A-1NSR	ALS240A-1
	SSOP – DB	Tape and reel	SN74ALS240ADBR	G240A
SN74ALS240A-1DBR			G240A-1	

† Package drawings, standard packing quantities, thermal data, symbolization, and PCB design guidelines are available at www.ti.com/sc/package.



Please be aware that an important notice concerning availability, standard warranty, and use in critical applications of Texas Instruments semiconductor products and disclaimers thereto appears at the end of this data sheet.

PRODUCTION DATA information is current as of publication date. Products conform to specifications per the terms of Texas Instruments standard warranty. Production processing does not necessarily include testing of all parameters.

 **TEXAS
INSTRUMENTS**

POST OFFICE BOX 655303 • DALLAS, TEXAS 75265

Copyright © 2002, Texas Instruments Incorporated
On products compliant to MIL-PRF-38535, all parameters are tested unless otherwise noted. On all other products, production processing does not necessarily include testing of all parameters.

SN54ALS240A, SN54AS240A, SN74ALS240A, SN74AS240A
OCTAL BUFFERS/DRIVERS
WITH 3-STATE OUTPUTS

SDAS214E – DECEMBER 1982 – REVISED AUGUST 2002

description/ordering information (continued)

ORDERING INFORMATION

TA	PACKAGE†		ORDERABLE PART NUMBER	TOP-SIDE MARKING
-55°C to 125°C	CDIP – J	Tube	SNJ54ALS240AJ	SNJ54ALS240AJ
			SNJ54AS240AJ	SNJ54AS240AJ
	CFP – W	Tube	SNJ54ALS240AW	SNJ54ALS240AW
			SNJ54AS240AW	SNJ54AS240AW
	LCCC – FK	Tube	SNJ54ALS240AFK	SNJ54ALS240AFK
			SNJ54AS240AFK	SNJ54AS240AFK

† Package drawings, standard packing quantities, thermal data, symbolization, and PCB design guidelines are available at www.ti.com/sc/package.

FUNCTION TABLE
(each buffer)

INPUTS		OUTPUT
\overline{OE}	A	Y
L	H	L
L	L	H
H	X	Z



SN54ALS240A, SN54AS240A, SN74ALS240A, SN74AS240A OCTAL BUFFERS/DRIVERS WITH 3-STATE OUTPUTS

SDAS214E – DECEMBER 1982 – REVISED AUGUST 2002

logic diagram (positive logic)

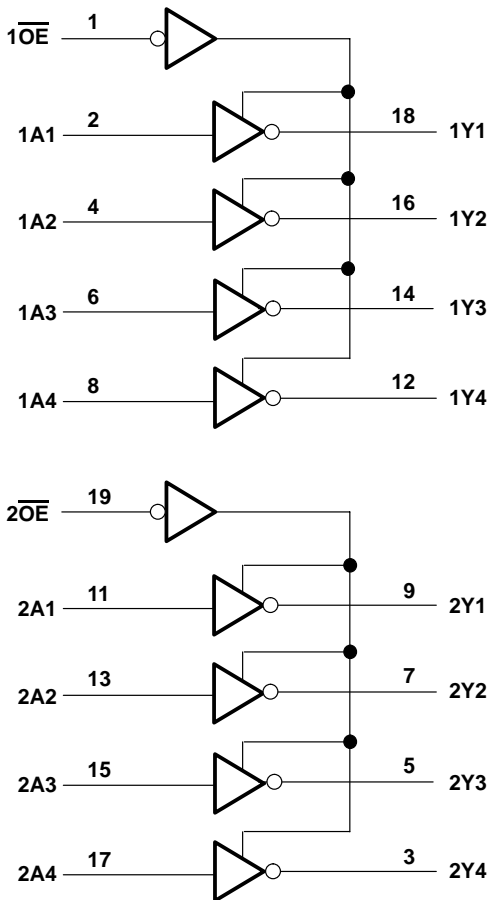

absolute maximum ratings over operating free-air temperature range (unless otherwise noted)†

Supply voltage, V_{CC}	7 V
Input voltage, V_I	7 V
Voltage applied to a disabled 3-state output	5.5 V
Package thermal impedance, θ_{JA} (see Note 1):	
DB package	70°C/W
DW package	58°C/W
N package	70°C/W
NS package	60°C/W
Storage temperature range, T_{Stg}	-65°C to 150°C

† Stresses beyond those listed under “absolute maximum ratings” may cause permanent damage to the device. These are stress ratings only, and functional operation of the device at these or any other conditions beyond those indicated under “recommended operating conditions” is not implied. Exposure to absolute-maximum-rated conditions for extended periods may affect device reliability.

NOTE 1: The package thermal impedance is calculated in accordance with JESD 51-7.



SN54ALS240A, SN54AS240A, SN74ALS240A, SN74AS240A OCTAL BUFFERS/DRIVERS WITH 3-STATE OUTPUTS

SDAS214E – DECEMBER 1982 – REVISED AUGUST 2002

recommended operating conditions

		MIN	NOM	MAX	UNIT
V _{CC}	Supply voltage	4.5	5	5.5	V
V _{IH}	High-level input voltage	2			V
V _{IL}	Low-level input voltage	SN54ALS240A		0.7	V
		SN74ALS240A, 'AS240A		0.8	
I _{OH}	High-level output current	SN54ALS240A, SN54AS240A		-12	mA
		SN74ALS240A, SN74AS240A		-15	
I _{OL}	Low-level output current	SN54ALS240A		12	mA
		SN74ALS240A		24	
				48†	
				64	
T _A	Operating free-air temperature	SN54ALS240A, SN54AS240A		-55	°C
		SN74ALS240A, SN74AS240A		0	

† Applies only to the -1 version and only if V_{CC} is between 4.75 V and 5.25 V

electrical characteristics over recommended operating free-air temperature range (unless otherwise noted)

PARAMETER	TEST CONDITIONS	SN54ALS240A		SN74ALS240A		UNIT	
		MIN	TYP‡	MAX	MIN		TYP‡
V _{IK}	V _{CC} = 4.5 V, I _I = -18 mA			-1.2		V	
V _{OH}	V _{CC} = 4.5 V to 5.5 V, I _{OH} = -0.4 mA	V _{CC} - 2		V _{CC} - 2		V	
	V _{CC} = 4.5 V	I _{OH} = -3 mA	2.4	3.2	2.4		3.2
		I _{OH} = -12 mA	2				
V _{OL}	V _{CC} = 4.5 V	I _{OL} = -15 mA			2		
		I _{OL} = 12 mA	0.25	0.4	0.25	0.4	
		I _{OL} = 24 mA			0.35	0.5	
		I _{OL} = 48 mA†			0.35	0.5	
I _{OZH}	V _{CC} = 5.5 V, V _O = 2.7 V			20		μA	
I _{OZL}	V _{CC} = 5.5 V, V _O = 0.4 V			-20		μA	
I _I	V _{CC} = 5.5 V, V _I = 7 V			0.1		mA	
I _{IH}	V _{CC} = 5.5 V, V _I = 2.7 V			20		μA	
I _{IL}	V _{CC} = 5.5 V, V _I = 0.4 V			-0.1		mA	
I _{O§}	V _{CC} = 5.5 V, V _O = 2.25 V	-20		-112	-30	-112	mA
I _{CC}	V _{CC} = 5.5 V	Outputs high		4	11	4	11
		Outputs low		13	23	13	23
		Outputs disabled		14	25	14	25

† Applies only to the -1 version and only if V_{CC} is between 4.75 V and 5.25 V

‡ All typical values are at V_{CC} = 5 V, T_A = 25°C.

§ The output conditions have been chosen to produce a current that closely approximates one-half of the true short-circuit output current, I_{OS}.



SN54ALS240A, SN54AS240A, SN74ALS240A, SN74AS240A OCTAL BUFFERS/DRIVERS WITH 3-STATE OUTPUTS

SDAS214E – DECEMBER 1982 – REVISED AUGUST 2002

electrical characteristics over recommended operating free-air temperature range (unless otherwise noted)

PARAMETER	TEST CONDITIONS		SN54AS240A		SN74AS240A		UNIT
			MIN	TYP†	MAX	MIN	
V_{IK}	$V_{CC} = 4.5\text{ V}$,	$I_I = -18\text{ mA}$	-1.2		-1.2		V
V_{OH}	$V_{CC} = 4.5\text{ V to } 5.5\text{ V}$	$I_{OH} = -2\text{ mA}$	$V_{CC} - 2$		$V_{CC} - 2$		V
		$I_{OH} = -3\text{ mA}$	2.4	3.4	2.4	3.4	
	$V_{CC} = 4.5\text{ V}$	$I_{OH} = -12\text{ mA}$	2.4				
		$I_{OH} = -15\text{ mA}$			2.4		
V_{OL}	$V_{CC} = 4.5\text{ V}$	$I_{OL} = 48\text{ mA}$	0.27	0.55			V
		$I_{OL} = 64\text{ mA}$			0.31	0.55	
I_{OZH}	$V_{CC} = 5.5\text{ V}$,	$V_O = 2.7\text{ V}$	50		50		μA
I_{OZL}	$V_{CC} = 5.5\text{ V}$,	$V_O = 0.4\text{ V}$	-50		-50		μA
I_I	$V_{CC} = 5.5\text{ V}$,	$V_I = 7\text{ V}$	0.1		0.1		mA
I_{IH}	$V_{CC} = 5.5\text{ V}$,	$V_I = 2.7\text{ V}$	20		20		μA
I_{IL}	A inputs	$V_{CC} = 5.5\text{ V}$,	-1		-1		mA
	\overline{OE} inputs		-0.5		-0.5		
$I_{O\ddagger}$	$V_{CC} = 5.5\text{ V}$,	$V_O = 2.25\text{ V}$	-50	-150	-50	-150	mA
I_{CC}	$V_{CC} = 5.5\text{ V}$	Outputs high	11	17	11	17	mA
		Outputs low	51	75	51	75	
		Outputs disabled	24	38	24	38	

† All typical values are at $V_{CC} = 5\text{ V}$, $T_A = 25^\circ\text{C}$.

‡ The output conditions have been chosen to produce a current that closely approximates one-half of the true short-circuit output current, I_{OS} .

switching characteristics (see Figure 1)

PARAMETER	FROM (INPUT)	TO (OUTPUT)	$V_{CC} = 4.5\text{ V to } 5.5\text{ V}$, $C_L = 50\text{ pF}$, $R_1 = 500\ \Omega$, $R_2 = 500\ \Omega$, $T_A = \text{MIN to MAX}\S$				UNIT
			SN54ALS240A		SN74ALS240A		
			MIN	MAX	MIN	MAX	
t_{PLH}	A	Y	2	22	2	9	ns
t_{PHL}			2	11	2	9	
t_{PZH}	\overline{OE}	Y	4	34	5	13	ns
t_{PZL}			5	26	5	18	
t_{PHZ}	\overline{OE}	Y	1	15	2	10	ns
t_{PLZ}			3	24	3	12	

§ For conditions shown as MIN or MAX, use the appropriate value specified under recommended operating conditions.



SN54ALS240A, SN54AS240A, SN74ALS240A, SN74AS240A
OCTAL BUFFERS/DRIVERS
WITH 3-STATE OUTPUTS

SDAS214E – DECEMBER 1982 – REVISED AUGUST 2002

switching characteristics (see Figure 1)

PARAMETER	FROM (INPUT)	TO (OUTPUT)	V _{CC} = 4.5 V to 5.5 V, C _L = 50 pF, R1 = 500 Ω, R2 = 500 Ω, T _A = MIN to MAX†				UNIT
			SN54AS240A		SN74AS240A		
			MIN	MAX	MIN	MAX	
t _{PLH}	A	Y	1	7	1	6.5	ns
t _{PHL}			1.2	6.5	1.2	6.5	
t _{PZH}	\overline{OE}	Y	1	7	1	6.4	ns
t _{PZL}			1.1	9.5	1.1	9	
t _{PHZ}	\overline{OE}	Y	1.2	5.5	1.2	5	ns
t _{PLZ}			1.5	12.5	1.5	9.5	

† For conditions shown as MIN or MAX, use the appropriate value specified under recommended operating conditions.



SN54ALS240A, SN54AS240A, SN74ALS240A, SN74AS240A OCTAL BUFFERS/DRIVERS WITH 3-STATE OUTPUTS

SDAS214E – DECEMBER 1982 – REVISED AUGUST 2002

PARAMETER MEASUREMENT INFORMATION SERIES 54ALS/74ALS AND 54AS/74AS DEVICES

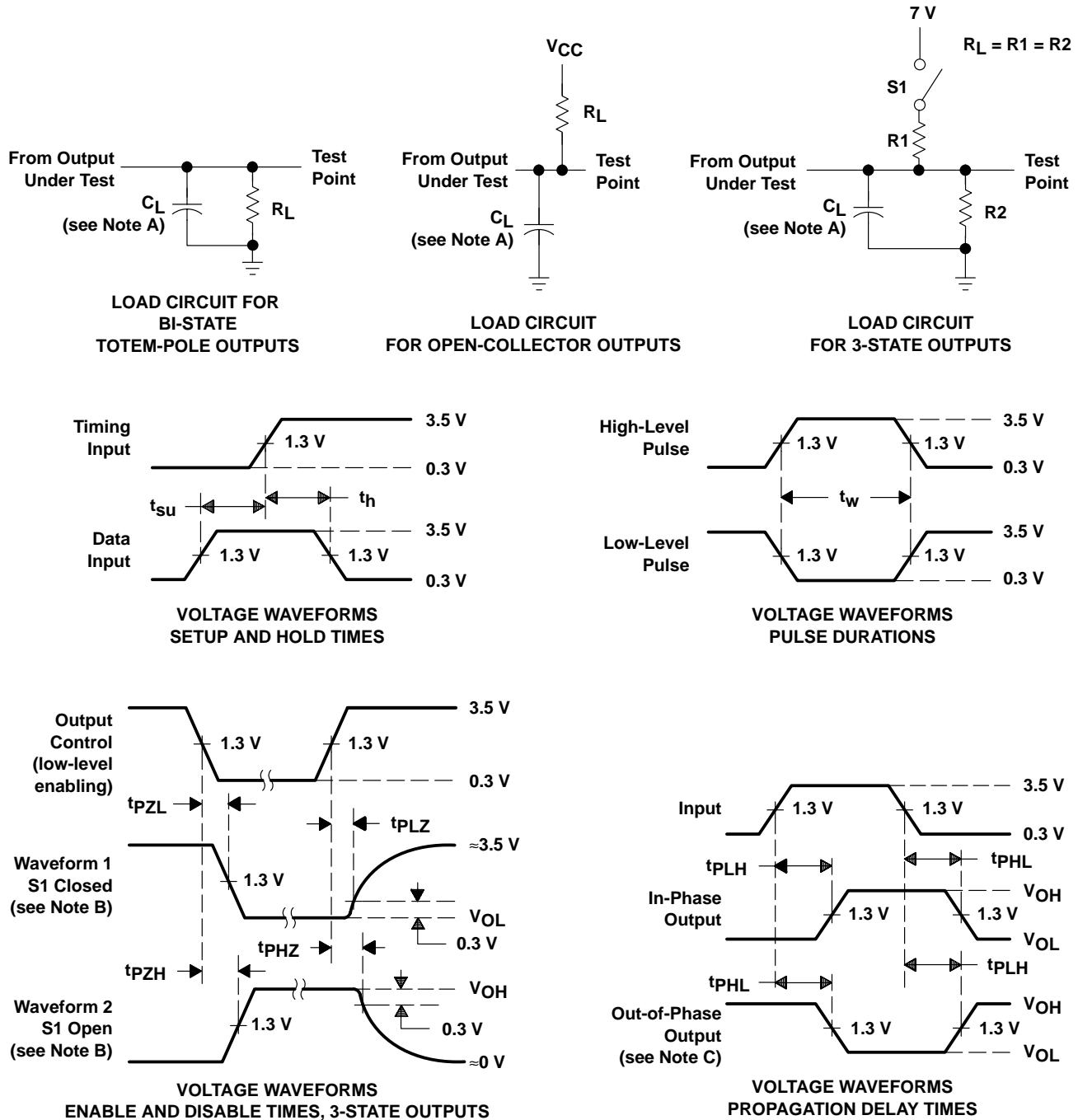

- NOTES: A. C_L includes probe and jig capacitance.
 B. Waveform 1 is for an output with internal conditions such that the output is low except when disabled by the output control. Waveform 2 is for an output with internal conditions such that the output is high except when disabled by the output control.
 C. When measuring propagation delay items of 3-state outputs, switch S1 is open.
 D. All input pulses have the following characteristics: $PRR \leq 1$ MHz, $t_r = t_f = 2$ ns, duty cycle = 50%.
 E. The outputs are measured one at a time with one transition per measurement.

Figure 1. Load Circuits and Voltage Waveforms

PACKAGING INFORMATION

Orderable part number	Status (1)	Material type (2)	Package Pins	Package qty Carrier	RoHS (3)	Lead finish/ Ball material (4)	MSL rating/ Peak reflow (5)	Op temp (°C)	Part marking (6)
5962-8859101SA	Active	Production	CFP (W) 20	25 TUBE	No	SNPB	N/A for Pkg Type	-55 to 125	5962-8859101SA SNJ54ALS240AW
JM38510/38301B2A	Active	Production	LCCC (FK) 20	55 TUBE	No	SNPB	N/A for Pkg Type	-55 to 125	JM38510/ 38301B2A
JM38510/38301B2A.A	Active	Production	LCCC (FK) 20	55 TUBE	No	SNPB	N/A for Pkg Type	-55 to 125	JM38510/ 38301B2A
JM38510/38301BRA	Active	Production	CDIP (J) 20	20 TUBE	No	SNPB	N/A for Pkg Type	-55 to 125	JM38510/ 38301BRA
JM38510/38301BRA.A	Active	Production	CDIP (J) 20	20 TUBE	No	SNPB	N/A for Pkg Type	-55 to 125	JM38510/ 38301BRA
M38510/38301B2A	Active	Production	LCCC (FK) 20	55 TUBE	No	SNPB	N/A for Pkg Type	-55 to 125	JM38510/ 38301B2A
M38510/38301BRA	Active	Production	CDIP (J) 20	20 TUBE	No	SNPB	N/A for Pkg Type	-55 to 125	JM38510/ 38301BRA
SN54ALS240AJ	Active	Production	CDIP (J) 20	20 TUBE	No	SNPB	N/A for Pkg Type	-55 to 125	SN54ALS240AJ
SN54ALS240AJ.A	Active	Production	CDIP (J) 20	20 TUBE	No	SNPB	N/A for Pkg Type	-55 to 125	SN54ALS240AJ
SN74ALS240A-1DW	Active	Production	SOIC (DW) 20	25 TUBE	Yes	NIPDAU	Level-1-260C-UNLIM	0 to 70	ALS240A-1
SN74ALS240A-1DW.A	Active	Production	SOIC (DW) 20	25 TUBE	Yes	NIPDAU	Level-1-260C-UNLIM	0 to 70	ALS240A-1
SN74ALS240A-1N	Active	Production	PDIP (N) 20	20 TUBE	Yes	NIPDAU	N/A for Pkg Type	0 to 70	SN74ALS240A-1N
SN74ALS240A-1N.A	Active	Production	PDIP (N) 20	20 TUBE	Yes	NIPDAU	N/A for Pkg Type	0 to 70	SN74ALS240A-1N
SN74ALS240A-1NSR	Active	Production	SOP (NS) 20	2000 LARGE T&R	Yes	NIPDAU	Level-1-260C-UNLIM	0 to 70	ALS240A-1
SN74ALS240A-1NSR.A	Active	Production	SOP (NS) 20	2000 LARGE T&R	Yes	NIPDAU	Level-1-260C-UNLIM	0 to 70	ALS240A-1
SN74ALS240ADBR	Active	Production	SSOP (DB) 20	2000 LARGE T&R	Yes	NIPDAU	Level-1-260C-UNLIM	-	G240A
SN74ALS240ADBR.A	Active	Production	SSOP (DB) 20	2000 LARGE T&R	Yes	NIPDAU	Level-1-260C-UNLIM	0 to 70	G240A
SN74ALS240ADW	Active	Production	SOIC (DW) 20	25 TUBE	Yes	NIPDAU	Level-1-260C-UNLIM	0 to 70	ALS240A
SN74ALS240ADW.A	Active	Production	SOIC (DW) 20	25 TUBE	Yes	NIPDAU	Level-1-260C-UNLIM	0 to 70	ALS240A
SN74ALS240ADWR	Active	Production	SOIC (DW) 20	2000 LARGE T&R	Yes	NIPDAU	Level-1-260C-UNLIM	0 to 70	ALS240A
SN74ALS240ADWR.A	Active	Production	SOIC (DW) 20	2000 LARGE T&R	Yes	NIPDAU	Level-1-260C-UNLIM	0 to 70	ALS240A
SN74ALS240AN	Active	Production	PDIP (N) 20	20 TUBE	Yes	NIPDAU	N/A for Pkg Type	0 to 70	SN74ALS240AN
SN74ALS240AN.A	Active	Production	PDIP (N) 20	20 TUBE	Yes	NIPDAU	N/A for Pkg Type	0 to 70	SN74ALS240AN
SN74ALS240ANSR	Active	Production	SOP (NS) 20	2000 LARGE T&R	Yes	NIPDAU	Level-1-260C-UNLIM	0 to 70	ALS240A

Orderable part number	Status (1)	Material type (2)	Package Pins	Package qty Carrier	RoHS (3)	Lead finish/ Ball material (4)	MSL rating/ Peak reflow (5)	Op temp (°C)	Part marking (6)
SN74ALS240ANSR.A	Active	Production	SOP (NS) 20	2000 LARGE T&R	Yes	NIPDAU	Level-1-260C-UNLIM	0 to 70	ALS240A
SN74AS240ADW	Active	Production	SOIC (DW) 20	25 TUBE	Yes	NIPDAU	Level-1-260C-UNLIM	0 to 70	AS240A
SN74AS240ADW.A	Active	Production	SOIC (DW) 20	25 TUBE	Yes	NIPDAU	Level-1-260C-UNLIM	0 to 70	AS240A
SN74AS240AN	Active	Production	PDIP (N) 20	20 TUBE	Yes	NIPDAU	N/A for Pkg Type	0 to 70	SN74AS240AN
SN74AS240AN.A	Active	Production	PDIP (N) 20	20 TUBE	Yes	NIPDAU	N/A for Pkg Type	0 to 70	SN74AS240AN
SN74AS240ANSR	Active	Production	SOP (NS) 20	2000 LARGE T&R	Yes	NIPDAU	Level-1-260C-UNLIM	0 to 70	74AS240A
SN74AS240ANSR.A	Active	Production	SOP (NS) 20	2000 LARGE T&R	Yes	NIPDAU	Level-1-260C-UNLIM	0 to 70	74AS240A
SNJ54ALS240AFK	Active	Production	LCCC (FK) 20	55 TUBE	No	SNPB	N/A for Pkg Type	-55 to 125	SNJ54ALS 240AFK
SNJ54ALS240AFK.A	Active	Production	LCCC (FK) 20	55 TUBE	No	SNPB	N/A for Pkg Type	-55 to 125	SNJ54ALS 240AFK
SNJ54ALS240AJ	Active	Production	CDIP (J) 20	20 TUBE	No	SNPB	N/A for Pkg Type	-55 to 125	SNJ54ALS240AJ
SNJ54ALS240AJ.A	Active	Production	CDIP (J) 20	20 TUBE	No	SNPB	N/A for Pkg Type	-55 to 125	SNJ54ALS240AJ
SNJ54ALS240AW	Active	Production	CFP (W) 20	25 TUBE	No	SNPB	N/A for Pkg Type	-55 to 125	5962-8859101SA SNJ54ALS240AW
SNJ54ALS240AW.A	Active	Production	CFP (W) 20	25 TUBE	No	SNPB	N/A for Pkg Type	-55 to 125	5962-8859101SA SNJ54ALS240AW
SNJ54AS240AJ	Active	Production	CDIP (J) 20	20 TUBE	No	SNPB	N/A for Pkg Type	-55 to 125	SNJ54AS240AJ
SNJ54AS240AJ.A	Active	Production	CDIP (J) 20	20 TUBE	No	SNPB	N/A for Pkg Type	-55 to 125	SNJ54AS240AJ

(1) **Status:** For more details on status, see our [product life cycle](#).

(2) **Material type:** When designated, preproduction parts are prototypes/experimental devices, and are not yet approved or released for full production. Testing and final process, including without limitation quality assurance, reliability performance testing, and/or process qualification, may not yet be complete, and this item is subject to further changes or possible discontinuation. If available for ordering, purchases will be subject to an additional waiver at checkout, and are intended for early internal evaluation purposes only. These items are sold without warranties of any kind.

(3) **RoHS values:** Yes, No, RoHS Exempt. See the [TI RoHS Statement](#) for additional information and value definition.

(4) **Lead finish/Ball material:** Parts may have multiple material finish options. Finish options are separated by a vertical ruled line. Lead finish/Ball material values may wrap to two lines if the finish value exceeds the maximum column width.

(5) **MSL rating/Peak reflow:** The moisture sensitivity level ratings and peak solder (reflow) temperatures. In the event that a part has multiple moisture sensitivity ratings, only the lowest level per JEDEC standards is shown. Refer to the shipping label for the actual reflow temperature that will be used to mount the part to the printed circuit board.

(6) Part marking: There may be an additional marking, which relates to the logo, the lot trace code information, or the environmental category of the part.

Multiple part markings will be inside parentheses. Only one part marking contained in parentheses and separated by a "~" will appear on a part. If a line is indented then it is a continuation of the previous line and the two combined represent the entire part marking for that device.

Important Information and Disclaimer: The information provided on this page represents TI's knowledge and belief as of the date that it is provided. TI bases its knowledge and belief on information provided by third parties, and makes no representation or warranty as to the accuracy of such information. Efforts are underway to better integrate information from third parties. TI has taken and continues to take reasonable steps to provide representative and accurate information but may not have conducted destructive testing or chemical analysis on incoming materials and chemicals. TI and TI suppliers consider certain information to be proprietary, and thus CAS numbers and other limited information may not be available for release.

In no event shall TI's liability arising out of such information exceed the total purchase price of the TI part(s) at issue in this document sold by TI to Customer on an annual basis.

OTHER QUALIFIED VERSIONS OF SN54ALS240A, SN54AS240A, SN74ALS240A, SN74AS240A :

- Catalog : [SN74ALS240A](#), [SN74AS240A](#)
- Military : [SN54ALS240A](#), [SN54AS240A](#)

NOTE: Qualified Version Definitions:

- Catalog - TI's standard catalog product
- Military - QML certified for Military and Defense Applications

TAPE AND REEL INFORMATION

QUADRANT ASSIGNMENTS FOR PIN 1 ORIENTATION IN TAPE

*All dimensions are nominal

Device	Package Type	Package Drawing	Pins	SPQ	Reel Diameter (mm)	Reel Width W1 (mm)	A0 (mm)	B0 (mm)	K0 (mm)	P1 (mm)	W (mm)	Pin1 Quadrant
SN74ALS240A-1NSR	SOP	NS	20	2000	330.0	24.4	8.4	13.0	2.5	12.0	24.0	Q1
SN74ALS240ADBR	SSOP	DB	20	2000	330.0	16.4	8.2	7.5	2.5	12.0	16.0	Q1
SN74ALS240ADWR	SOIC	DW	20	2000	330.0	24.4	10.8	13.3	2.7	12.0	24.0	Q1
SN74ALS240ANSR	SOP	NS	20	2000	330.0	24.4	8.4	13.0	2.5	12.0	24.0	Q1
SN74AS240ANSR	SOP	NS	20	2000	330.0	24.4	8.4	13.0	2.5	12.0	24.0	Q1

TAPE AND REEL BOX DIMENSIONS



*All dimensions are nominal

Device	Package Type	Package Drawing	Pins	SPQ	Length (mm)	Width (mm)	Height (mm)
SN74ALS240A-1NSR	SOP	NS	20	2000	367.0	367.0	45.0
SN74ALS240ADBR	SSOP	DB	20	2000	356.0	356.0	35.0
SN74ALS240ADWR	SOIC	DW	20	2000	367.0	367.0	45.0
SN74ALS240ANSR	SOP	NS	20	2000	367.0	367.0	45.0
SN74AS240ANSR	SOP	NS	20	2000	367.0	367.0	45.0

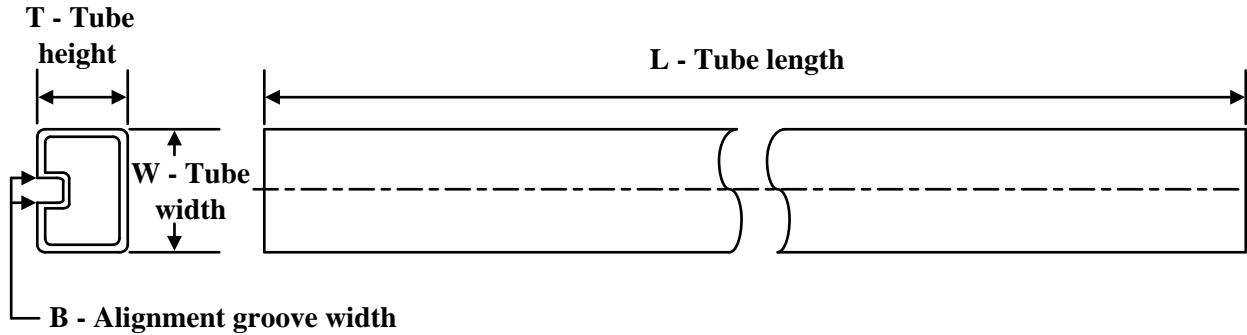
TUBE

*All dimensions are nominal

Device	Package Name	Package Type	Pins	SPQ	L (mm)	W (mm)	T (μm)	B (mm)
5962-8859101SA	W	CFP	20	25	506.98	26.16	6220	NA
JM38510/38301B2A	FK	LCCC	20	55	506.98	12.06	2030	NA
JM38510/38301B2A.A	FK	LCCC	20	55	506.98	12.06	2030	NA
M38510/38301B2A	FK	LCCC	20	55	506.98	12.06	2030	NA
SN74ALS240A-1DW	DW	SOIC	20	25	507	12.83	5080	6.6
SN74ALS240A-1DW.A	DW	SOIC	20	25	507	12.83	5080	6.6
SN74ALS240A-1N	N	PDIP	20	20	506	13.97	11230	4.32
SN74ALS240A-1N.A	N	PDIP	20	20	506	13.97	11230	4.32
SN74ALS240ADW	DW	SOIC	20	25	507	12.83	5080	6.6
SN74ALS240ADW.A	DW	SOIC	20	25	507	12.83	5080	6.6
SN74ALS240AN	N	PDIP	20	20	506	13.97	11230	4.32
SN74ALS240AN.A	N	PDIP	20	20	506	13.97	11230	4.32
SN74AS240ADW	DW	SOIC	20	25	507	12.83	5080	6.6
SN74AS240ADW.A	DW	SOIC	20	25	507	12.83	5080	6.6
SN74AS240AN	N	PDIP	20	20	506	13.97	11230	4.32
SN74AS240AN.A	N	PDIP	20	20	506	13.97	11230	4.32
SNJ54ALS240AFK	FK	LCCC	20	55	506.98	12.06	2030	NA
SNJ54ALS240AFK.A	FK	LCCC	20	55	506.98	12.06	2030	NA
SNJ54ALS240AW	W	CFP	20	25	506.98	26.16	6220	NA
SNJ54ALS240AW.A	W	CFP	20	25	506.98	26.16	6220	NA

W (R-GDFP-F20)

CERAMIC DUAL FLATPACK



4040180-4/F 04/14

- NOTES:
- A. All linear dimensions are in inches (millimeters).
 - B. This drawing is subject to change without notice.
 - C. This package can be hermetically sealed with a ceramic lid using glass frit.
 - D. Index point is provided on cap for terminal identification only.
 - E. Falls within Mil-Std 1835 GDFP2-F20

DB0020A



PACKAGE OUTLINE

SSOP - 2 mm max height

SMALL OUTLINE PACKAGE



4214851/B 08/2019

EXAMPLE BOARD LAYOUT

DB0020A

SSOP - 2 mm max height

SMALL OUTLINE PACKAGE



LAND PATTERN EXAMPLE
EXPOSED METAL SHOWN
SCALE: 10X



4214851/B 08/2019

NOTES: (continued)

- 6. Publication IPC-7351 may have alternate designs.
- 7. Solder mask tolerances between and around signal pads can vary based on board fabrication site.

EXAMPLE STENCIL DESIGN

DB0020A

SSOP - 2 mm max height

SMALL OUTLINE PACKAGE



SOLDER PASTE EXAMPLE
BASED ON 0.125 mm THICK STENCIL
SCALE: 10X

4214851/B 08/2019

NOTES: (continued)

8. Laser cutting apertures with trapezoidal walls and rounded corners may offer better paste release. IPC-7525 may have alternate design recommendations.
9. Board assembly site may have different recommendations for stencil design.

MECHANICAL DATA

NS (R-PDSO-G**)

PLASTIC SMALL-OUTLINE PACKAGE

14-PINS SHOWN



- NOTES:
- A. All linear dimensions are in millimeters.
 - B. This drawing is subject to change without notice.
 - C. Body dimensions do not include mold flash or protrusion, not to exceed 0,15.

J (R-GDIP-T**)

14 LEADS SHOWN

CERAMIC DUAL IN-LINE PACKAGE



DIM \ PINS **	14	16	18	20
A	0.300 (7,62) BSC	0.300 (7,62) BSC	0.300 (7,62) BSC	0.300 (7,62) BSC
B MAX	0.785 (19,94)	.840 (21,34)	0.960 (24,38)	1.060 (26,92)
B MIN	—	—	—	—
C MAX	0.300 (7,62)	0.300 (7,62)	0.310 (7,87)	0.300 (7,62)
C MIN	0.245 (6,22)	0.245 (6,22)	0.220 (5,59)	0.245 (6,22)



4040083/F 03/03

- NOTES:
- All linear dimensions are in inches (millimeters).
 - This drawing is subject to change without notice.
 - This package is hermetically sealed with a ceramic lid using glass frit.
 - Index point is provided on cap for terminal identification only on press ceramic glass frit seal only.
 - Falls within MIL STD 1835 GDIP1-T14, GDIP1-T16, GDIP1-T18 and GDIP1-T20.

GENERIC PACKAGE VIEW

FK 20

LCCC - 2.03 mm max height

8.89 x 8.89, 1.27 mm pitch

LEADLESS CERAMIC CHIP CARRIER

This image is a representation of the package family, actual package may vary.
Refer to the product data sheet for package details.



4229370VA\

N (R-PDIP-T**)

PLASTIC DUAL-IN-LINE PACKAGE

16 PINS SHOWN



- NOTES:
- A. All linear dimensions are in inches (millimeters).
 - B. This drawing is subject to change without notice.
 - Falls within JEDEC MS-001, except 18 and 20 pin minimum body length (Dim A).
 - The 20 pin end lead shoulder width is a vendor option, either half or full width.

DW0020A



PACKAGE OUTLINE

SOIC - 2.65 mm max height

SOIC



4220724/A 05/2016

NOTES:

1. All linear dimensions are in millimeters. Dimensions in parenthesis are for reference only. Dimensioning and tolerancing per ASME Y14.5M.
2. This drawing is subject to change without notice.
3. This dimension does not include mold flash, protrusions, or gate burrs. Mold flash, protrusions, or gate burrs shall not exceed 0.15 mm per side.
4. This dimension does not include interlead flash. Interlead flash shall not exceed 0.43 mm per side.
5. Reference JEDEC registration MS-013.

EXAMPLE BOARD LAYOUT

DW0020A

SOIC - 2.65 mm max height

SOIC



LAND PATTERN EXAMPLE
SCALE:6X



SOLDER MASK DETAILS

4220724/A 05/2016

NOTES: (continued)

- 6. Publication IPC-7351 may have alternate designs.
- 7. Solder mask tolerances between and around signal pads can vary based on board fabrication site.

EXAMPLE STENCIL DESIGN

DW0020A

SOIC - 2.65 mm max height

SOIC



SOLDER PASTE EXAMPLE
BASED ON 0.125 mm THICK STENCIL
SCALE:6X

4220724/A 05/2016

NOTES: (continued)

8. Laser cutting apertures with trapezoidal walls and rounded corners may offer better paste release. IPC-7525 may have alternate design recommendations.
9. Board assembly site may have different recommendations for stencil design.

IMPORTANT NOTICE AND DISCLAIMER

TI PROVIDES TECHNICAL AND RELIABILITY DATA (INCLUDING DATA SHEETS), DESIGN RESOURCES (INCLUDING REFERENCE DESIGNS), APPLICATION OR OTHER DESIGN ADVICE, WEB TOOLS, SAFETY INFORMATION, AND OTHER RESOURCES "AS IS" AND WITH ALL FAULTS, AND DISCLAIMS ALL WARRANTIES, EXPRESS AND IMPLIED, INCLUDING WITHOUT LIMITATION ANY IMPLIED WARRANTIES OF MERCHANTABILITY, FITNESS FOR A PARTICULAR PURPOSE OR NON-INFRINGEMENT OF THIRD PARTY INTELLECTUAL PROPERTY RIGHTS.

These resources are intended for skilled developers designing with TI products. You are solely responsible for (1) selecting the appropriate TI products for your application, (2) designing, validating and testing your application, and (3) ensuring your application meets applicable standards, and any other safety, security, regulatory or other requirements.

These resources are subject to change without notice. TI grants you permission to use these resources only for development of an application that uses the TI products described in the resource. Other reproduction and display of these resources is prohibited. No license is granted to any other TI intellectual property right or to any third party intellectual property right. TI disclaims responsibility for, and you will fully indemnify TI and its representatives against, any claims, damages, costs, losses, and liabilities arising out of your use of these resources.

TI's products are provided subject to [TI's Terms of Sale](#) or other applicable terms available either on [ti.com](https://www.ti.com) or provided in conjunction with such TI products. TI's provision of these resources does not expand or otherwise alter TI's applicable warranties or warranty disclaimers for TI products.

TI objects to and rejects any additional or different terms you may have proposed.

Mailing Address: Texas Instruments, Post Office Box 655303, Dallas, Texas 75265

Copyright © 2025, Texas Instruments Incorporated