

3-V to 5.5-V Multichannel RS-232 Line Driver and Receiver with ± 15 -kV ESD Protection

1 Features

- ESD Protection for RS-232 bus pins
 - ± 15 -kV Human-body model (HBM)
 - ± 8 -kV IEC61000-4-2, Contact discharge
 - ± 15 -kV IEC61000-4-2, Air-gap discharge
- Meets or exceeds the requirements of TIA/EIA-232-F and ITU v.28 standards
- Operates with 3-V to 5.5-V V_{CC} supply
- Operates up to 500 kbit/s
- Two drivers and two receivers
- Low standby current: 1 μ A typical
- External capacitors: 4 \times 0.1 μ F
- Accepts 5-V logic input With 3.3-V supply
- Alternative high-speed pin-compatible device (1 Mbit/s) for SNx5C3223E

2 Applications

- [Battery-powered systems](#)
- [PDAs](#)
- [Notebooks](#)
- [Laptops](#)
- [Palm-top PCs](#)
- [Hand-held equipment](#)

DB, DW, OR PW PACKAGE
(TOP VIEW)

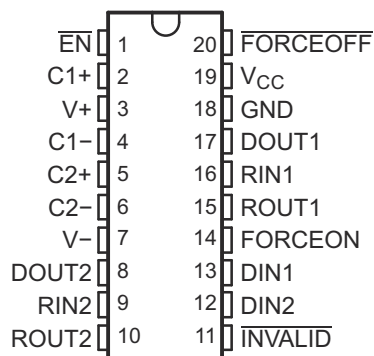

3 Description

The MAX3223E consists of two line drivers, two line receivers, and a dual charge-pump circuit with ± 15 -kV ESD protection pin to pin (serial-port connection pins, including GND). The device meets the requirements of TIA/EIA-232-F and provides the electrical interface between an asynchronous communication controller and the serial-port connector. The charge pump and four small external capacitors allow operation from a single 3-V to 5.5-V supply. The device operates at typical data signaling rates up to 500 kbit/s and a maximum of 30-V/ μ s driver output slew rate.

Flexible control options for power management are available when the serial port is inactive. The auto-powerdown feature functions when FORCEON is low and FORCEOFF is high. During this mode of operation, if the device does not sense a valid RS-232 signal, the driver outputs are disabled. If FORCEOFF is set low and EN is high, both drivers and receivers are shut off, and the supply current is reduced to 1 mA. Disconnecting the serial port or turning off the peripheral drivers causes auto-powerdown to occur. Auto-powerdown can be disabled when FORCEON and FORCEOFF are high. With auto-powerdown enabled, the device is activated automatically when a valid signal is applied to any receiver input. The INVALID output is used to notify the user if an RS-232 signal is present at any receiver input. INVALID is high (valid data) if any receiver input voltage is greater than 2.7 V or less than -2.7 V, or has been between -0.3 V and 0.3 V for less than 30 μ s. INVALID is low (invalid data) if the receiver input voltage is between -0.3 V and 0.3 V for more than 30 μ s. Refer to [Figure 5-4](#) for receiver input levels.

Package Information

PART NUMBER	PACKAGE ⁽¹⁾	PACKAGE SIZE ⁽²⁾
MAX3223E	SOIC (DW, 20)	12.8 mm \times 10.3 mm
	SSOP (DB, 20)	7.2 mm \times 7.8 mm
	TSSOP (PW, 20)	6.5 mm \times 6.4 mm

(1) For more information, see [Section 10](#).

(2) The package size (length \times width) is a nominal value and includes pins, where applicable.



Table of Contents

1 Features	1	6 Detailed Description	10
2 Applications	1	6.1 Functional Block Diagram.....	10
3 Description	1	6.2 Device Functional Modes.....	10
4 Specifications	3	7 Application and Implementation	11
4.1 Absolute Maximum Ratings.....	3	7.1 Typical Application.....	11
4.2 Recommended Operating Conditions.....	3	8 Device and Documentation Support	13
4.3 ESD Ratings.....	3	8.1 Receiving Notification of Documentation Updates... 13	
4.4 ESD Ratings - IEC Specifications.....	4	8.2 Support Resources.....	13
4.5 Thermal Information.....	4	8.3 Trademarks.....	13
4.6 Electrical Characteristics.....	4	8.4 Electrostatic Discharge Caution.....	13
4.7 Driver Section.....	4	8.5 Glossary.....	13
4.8 Receiver Section.....	5	9 Revision History	13
4.9 Auto-Powerdown Section.....	6	10 Mechanical, Packaging, and Orderable Information	13
5 Parameter Measurement Information	7		

4 Specifications

4.1 Absolute Maximum Ratings

over operating free-air temperature range (unless otherwise noted) ⁽¹⁾

		MIN	MAX	UNIT
V _{CC}	Supply voltage range	-0.3	6	V
V+	Positive-output supply voltage range ⁽²⁾	-0.3	7	V
V-	Negative-output supply voltage range ⁽²⁾	0.3	-7	V
V+ - V-	Supply voltage difference ⁽²⁾		13	V
V _I	Input voltage range	Driver (FORCEOFF, FORCEON, $\overline{\text{EN}}$)		V
		Receiver		
V _O	Output voltage range	Driver		V
		Receiver (INVALID)		
T _J	Operating virtual junction temperature		150	°C
T _{stg}	Storage temperature range	-65	150	°C

- (1) Stresses beyond those listed under "absolute maximum ratings" may cause permanent damage to the device. These are stress ratings only, and functional operation of the device at these or any other conditions beyond those indicated under "recommended operating conditions" is not implied. Exposure to absolute-maximum-rated conditions for extended periods may affect device reliability.
- (2) All voltages are with respect to network GND.

4.2 Recommended Operating Conditions

See [Figure 7-1](#), and ⁽¹⁾

		MIN	NOM	MAX	UNIT	
Supply voltage		V _{CC} = 3.3 V	3	3.3	3.6	V
		V _{CC} = 5 V	4.5	5	5.5	
V _{IH}	Driver and control high-level input voltage	DIN, $\overline{\text{EN}}$, FORCEOFF, FORCEON	V _{CC} = 3.3 V		V	
			V _{CC} = 5 V			
V _{IL}	Driver and control low-level input voltage	DIN, $\overline{\text{EN}}$, FORCEOFF, FORCEON		0.8	V	
V _I	Driver and control input voltage	DIN, $\overline{\text{EN}}$, FORCEOFF, FORCEON		0	5.5	V
	Receiver input voltage	-25		25	V	
T _A	Operating free-air temperature	MAX3223EC	0	70	°C	
		MAX3223EI	-40	85		

- (1) Test conditions are C1–C4 = 0.1 μF at V_{CC} = 3.3 V ± 0.3 V; C1 = 0.047 μF, C2–C4 = 0.33 μF at V_{CC} = 5 V ± 0.5 V.

4.3 ESD Ratings

		VALUE	UNIT
V _(ESD)	Electrostatic discharge	All pins except RIN1, RIN2, DOUT1 and DOUT2 pins	±3000
		RIN1, RIN2, DOUT1 and DOUT2 pins to GND	±15000
		All pins	±1500

- (1) JEDEC document JEP155 states that 500-V HBM allows safe manufacturing with a standard ESD control process.
- (2) JEDEC document JEP157 states that 250-V CDM allows safe manufacturing with a standard ESD control process.

4.4 ESD Ratings - IEC Specifications

		VALUE	UNIT
V _(ESD)	Electrostatic discharge	IEC 61000-4-2 Contact Discharge ⁽¹⁾	±8000
		IEC 61000-4-2 Air-gap Discharge ⁽¹⁾	±15,000

(1) A minimum of 1- μ F capacitor between V_{CC} and GND is required to meet the specified IEC 61000-4-2 rating.

4.5 Thermal Information

THERMAL METRIC ⁽¹⁾		DB (SOIC)	DW (SOIC)	PW (TSSOP)	UNIT
		20 PINS	20 PINS	20 PINS	
R _{θJA}	Junction-to-ambient thermal resistance	87.2	76.8	89.7	°C/W
R _{θJC(top)}	Junction-to-case (top) thermal resistance	41.1	39.6	29.0	°C/W
R _{θJB}	Junction-to-board thermal resistance	43.3	41.5	41.9	°C/W
ψ _{JT}	Junction-to-top characterization parameter	9.2	12.6	1.9	°C/W
ψ _{JB}	Junction-to-board characterization parameter	42.7	40.9	41.3	°C/W

(1) For more information about traditional and new thermal metrics, see the [Semiconductor and IC Package Thermal Metrics](#) application report.

4.6 Electrical Characteristics

over recommended ranges of supply voltage and operating free-air temperature (unless otherwise noted) (see [Figure 5-5](#)) and ⁽¹⁾

PARAMETER		TEST CONDITIONS	MIN	TYP ⁽²⁾	MAX	UNIT
I _I	Input leakage current	EN, FORCEOFF, FORCEON		±0.01	±1	μA
I _{CC}	Supply current	Auto-powerdown disabled	V _{CC} = 3.3 V or 5 V, T _A = 25°C, No load, FORCEOFF and FORCEON at V _{CC}	0.3	1.3	mA
		Powered off	No load, FORCEOFF at GND	1	10	
		Auto-powerdown enabled	No load, FORCEOFF at V _{CC} , FORCEON at GND, All RIN are open or grounded	1	10	μA

(1) Test conditions are C1–C4 = 0.1 μ F at V_{CC} = 3.3 V \pm 0.3 V; C1 = 0.047 μ F, C2–C4 = 0.33 μ F at V_{CC} = 5 V \pm 0.5 V.

(2) All typical values are at V_{CC} = 3.3 V or V_{CC} = 5 V, and T_A = 25°C.

4.7 Driver Section

4.7.1 Electrical Characteristics

over recommended ranges of supply voltage and operating free-air temperature (unless otherwise noted) (see [Figure 5-5](#)) and ⁽¹⁾

PARAMETER		TEST CONDITIONS	MIN	TYP ⁽²⁾	MAX	UNIT
V _{OH}	High-level output voltage	DOOUT at R _L = 3 k Ω to GND	5	5.4		V
V _{OL}	Low-level output voltage	DOOUT at R _L = 3 k Ω to GND	–5	–5.4		V
I _{IH}	High-level input current	V _I = V _{CC}		±0.01	±1	μA
I _{IL}	Low-level input current	V _I at GND		±0.01	±1	μA
I _{OS}	Short-circuit output current ⁽³⁾	V _{CC} = 3.6 V, V _O = 0 V		±35	±60	mA
		V _{CC} = 5.5 V, V _O = 0 V				
r _o	Output resistance	V _{CC} , V+, and V– = 0 V, V _O = \pm 2 V	300	10M		Ω
I _{OZ}	Output leakage current	FORCEOFF = GND, V _{CC} = 3 V to 3.6 V, V _O = \pm 12 V			±25	μA
		FORCEOFF = GND, V _{CC} = 4.5 V to 5.5 V, V _O = \pm 12 V			±25	

(1) Test conditions are C1–C4 = 0.1 μ F at V_{CC} = 3.3 V \pm 0.3 V; C1 = 0.047 μ F, C2–C4 = 0.33 μ F at V_{CC} = 5 V \pm 0.5 V.

(2) All typical values are at V_{CC} = 3.3 V or V_{CC} = 5 V, and T_A = 25°C.

- (3) Short-circuit durations should be controlled to prevent exceeding the device absolute power dissipation ratings, and not more than one output should be shorted at a time.

4.7.2 Switching Characteristics

over recommended ranges of supply voltage and operating free-air temperature (unless otherwise noted) (see [Figure 5-5](#)) and ⁽¹⁾

PARAMETER	TEST CONDITIONS	MIN	TYP ⁽²⁾	MAX	UNIT
Maximum data rate	$C_L = 1000$ pF, One DOUT switching, $R_L = 3$ k Ω , See Figure 5-1	250	500		kbit/s
$t_{sk(p)}$ Pulse skew ⁽³⁾	$C_L = 150$ pF to 2500 pF, See Figure 5-2		100		ns
SR(tr) Slew rate, transition region (See Figure 5-1)	$R_L = 3$ k Ω to 7 k Ω , $V_{CC} = 3.3$ V			30	V/ μ s
	$C_L = 150$ pF to 1000 pF $C_L = 150$ pF to 2500 pF	6 4		30	

- (1) Test conditions are $C1-C4 = 0.1$ μ F at $V_{CC} = 3.3$ V \pm 0.3 V; $C1 = 0.047$ μ F, $C2-C4 = 0.33$ μ F at $V_{CC} = 5$ V \pm 0.5 V.
(2) All typical values are at $V_{CC} = 3.3$ V or $V_{CC} = 5$ V, and $T_A = 25^\circ$ C.
(3) Pulse skew is defined as $|t_{PLH} - t_{PHL}|$ of each channel of the same device.

4.7.3 ESD Protection

		TYP	UNIT
Driver outputs (DOUTx)	Human-Body Model (HBM)	± 15	kV
	IEC61000-4-2, Air-Gap Discharge	± 15	
	IEC61000-4-2, Contact Discharge	± 8	

4.8 Receiver Section

4.8.1 Electrical Characteristics

over recommended ranges of supply voltage and operating free-air temperature (unless otherwise noted) (see [Figure 7-1](#)) and ⁽¹⁾

PARAMETER	TEST CONDITIONS	MIN	TYP ⁽²⁾	MAX	UNIT
V_{OH} High-level output voltage	$I_{OH} = -1$ mA	$V_{CC} - 0.6$	$V_{CC} - 0.1$		V
V_{OL} Low-level output voltage	$I_{OL} = 1.6$ mA			0.4	V
V_{IT+} Positive-going input threshold voltage	$V_{CC} = 3.3$ V		1.6	2.4	V
	$V_{CC} = 5$ V		1.9	2.4	
V_{IT-} Negative-going input threshold voltage	$V_{CC} = 3.3$ V	0.6	1.1		V
	$V_{CC} = 5$ V	0.6	1.4		
V_{hys} Input hysteresis ($V_{IT+} - V_{IT-}$)			0.5		V
I_{OZ} Output leakage current	$\overline{EN} = V_{CC}$		± 0.05		μ A
r_i Input resistance	$V_I = \pm 3$ V to ± 25 V	3	5		k Ω

- (1) Test conditions are $C1-C4 = 0.1$ μ F at $V_{CC} = 3.3$ V \pm 0.3 V; $C1 = 0.047$ μ F, $C2-C4 = 0.33$ μ F at $V_{CC} = 5$ V \pm 0.5 V.
(2) All typical values are at $V_{CC} = 3.3$ V or $V_{CC} = 5$ V, and $T_A = 25^\circ$ C.

4.8.2 Switching Characteristics

over recommended ranges of supply voltage and operating free-air temperature (unless otherwise noted) ⁽¹⁾

PARAMETER	TEST CONDITIONS	TYP ⁽²⁾	UNIT
t_{PLH} Propagation delay time, low- to high-level output	$C_L = 150$ pF, See Figure 5-3	150	ns
t_{PHL} Propagation delay time, high- to low-level output	$C_L = 150$ pF, See Figure 5-3	150	ns
t_{en} Output enable time	$C_L = 150$ pF, $R_L = 3$ k Ω , See Figure 5-4	200	ns
t_{dis} Output disable time	$C_L = 150$ pF, $R_L = 3$ k Ω , See Figure 5-4	200	ns
$t_{sk(p)}$ Pulse skew ⁽³⁾	See Figure 5-3	50	ns

- (1) Test conditions are $C1-C4 = 0.1$ μ F at $V_{CC} = 3.3$ V \pm 0.3 V; $C1 = 0.047$ μ F, $C2-C4 = 0.33$ μ F at $V_{CC} = 5$ V \pm 0.5 V.

MAX3223E

SLLS707B – JANUARY 2006 – REVISED DECEMBER 2023

- (2) All typical values are at $V_{CC} = 3.3\text{ V}$ or $V_{CC} = 5\text{ V}$, and $T_A = 25^\circ\text{C}$.
- (3) Pulse skew is defined as $|t_{PLH} - t_{PHL}|$ of each channel of the same device.

4.8.3 ESD Protection

		TYP	UNIT
Receiver inputs (RINx)	Human-Body Model (HBM)	±15	kV
	IEC61000-4-2, Air-Gap Discharge	±15	
	IEC61000-4-2, Contact Discharge	±8	

4.9 Auto-Powerdown Section

4.9.1 Electrical Characteristics

 over recommended ranges of supply voltage and operating free-air temperature (unless otherwise noted) (see [Figure 5-5](#))

PARAMETER		TEST CONDITIONS		MIN	MAX	UNIT
$V_{T+(\text{valid})}$	Receiver input threshold for $\overline{\text{INVALID}}$ high-level output voltage	FORCEON = GND,	FORCEOFF = V_{CC}		2.7	V
$V_{T(\text{valid})}$	Receiver input threshold for $\overline{\text{INVALID}}$ high-level output voltage	FORCEON = GND,	FORCEOFF = V_{CC}	-2.7		V
$V_{T(\text{invalid})}$	Receiver input threshold for $\overline{\text{INVALID}}$ low-level output voltage	FORCEON = GND,	FORCEOFF = V_{CC}	-0.3	0.3	V
V_{OH}	$\overline{\text{INVALID}}$ high-level output voltage	$I_{OH} = 1\text{ mA}$, FORCEOFF = V_{CC}	FORCEON = GND,	$V_{CC} - 0.6$		V
V_{OL}	$\overline{\text{INVALID}}$ low-level output voltage	$I_{OL} = 1.6\text{ mA}$, FORCEOFF = V_{CC}	FORCEON = GND,		0.4	V

4.9.2 Switching Characteristics

 over recommended ranges of supply voltage and operating free-air temperature (unless otherwise noted) (see [Figure 5-5](#))

PARAMETER		TYP ⁽¹⁾	UNIT
t_{valid}	Propagation delay time, low- to high-level output	1	µs
t_{invalid}	Propagation delay time, high- to low-level output	30	µs
t_{en}	Supply enable time	100	µs

- (1) All typical values are at $V_{CC} = 3.3\text{ V}$ or $V_{CC} = 5\text{ V}$, and $T_A = 25^\circ\text{C}$.

5 Parameter Measurement Information

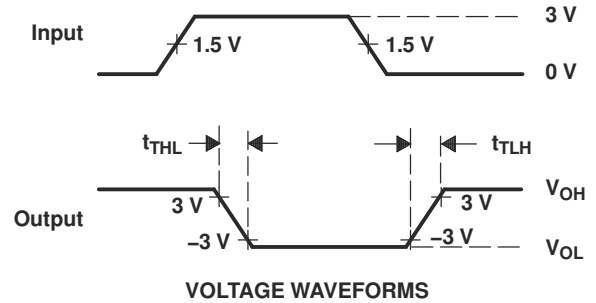
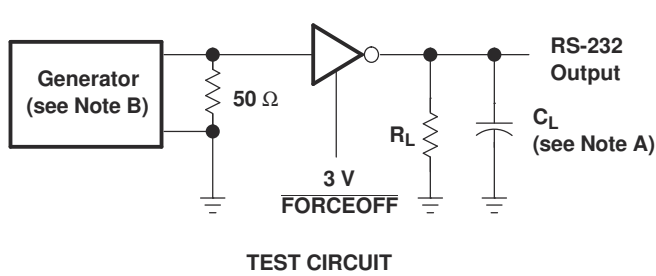

$$SR(tr) = \frac{6 V}{t_{THL} \text{ or } t_{TLH}}$$

- A. C_L includes probe and jig capacitance.
 B. The pulse generator has the following characteristics: PRR = 250 kbit/s, $Z_O = 50 \Omega$, 50% duty cycle, $t_r \leq 10 \text{ ns}$, $t_f \leq 10 \text{ ns}$.

Figure 5-1. Driver Slew Rate

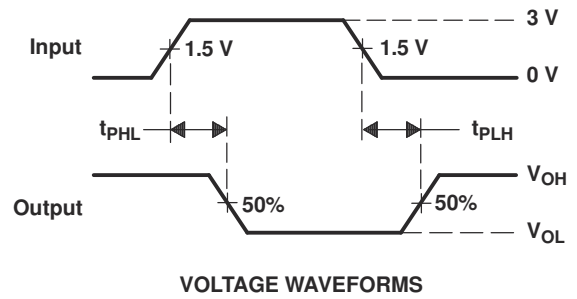
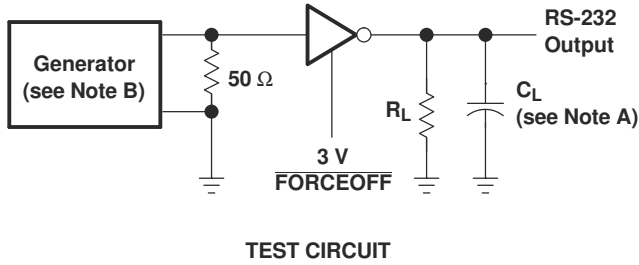

- A. C_L includes probe and jig capacitance.
 B. The pulse generator has the following characteristics: PRR = 250 kbit/s, $Z_O = 50 \Omega$, 50% duty cycle, $t_r \leq 10 \text{ ns}$, $t_f \leq 10 \text{ ns}$.

Figure 5-2. Driver Pulse Skew

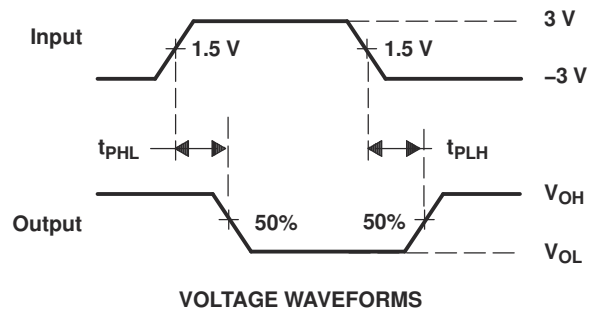
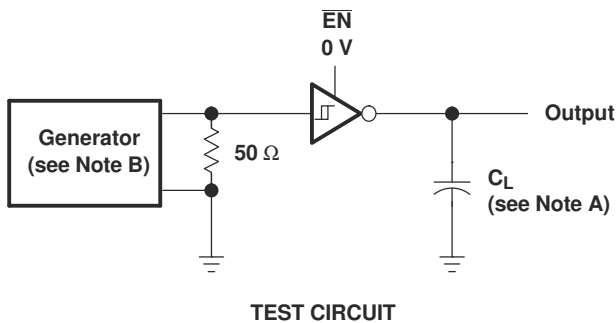

- A. C_L includes probe and jig capacitance.
 B. The pulse generator has the following characteristics: $Z_O = 50 \Omega$, 50% duty cycle, $t_r \leq 10 \text{ ns}$, $t_f \leq 10 \text{ ns}$.

Figure 5-3. Receiver Propagation Delay Times

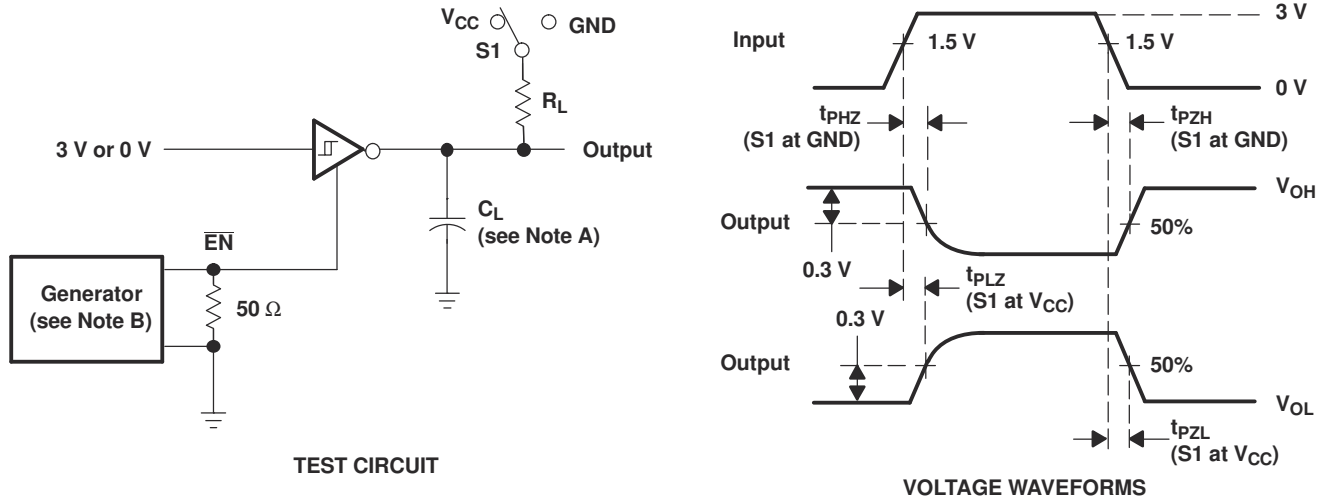

- A. C_L includes probe and jig capacitance.
- B. The pulse generator has the following characteristics: $Z_O = 50 \Omega$, 50% duty cycle, $t_r \leq 10 \text{ ns}$, $t_f \leq 10 \text{ ns}$.

Figure 5-4. Receiver Enable and Disable Times

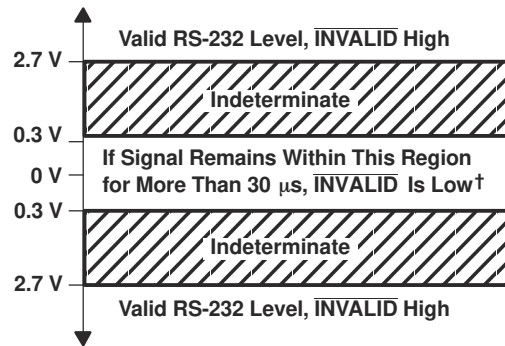
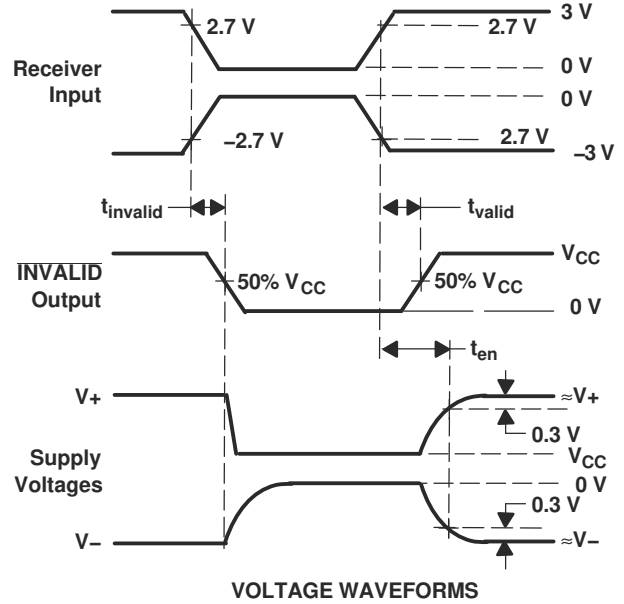
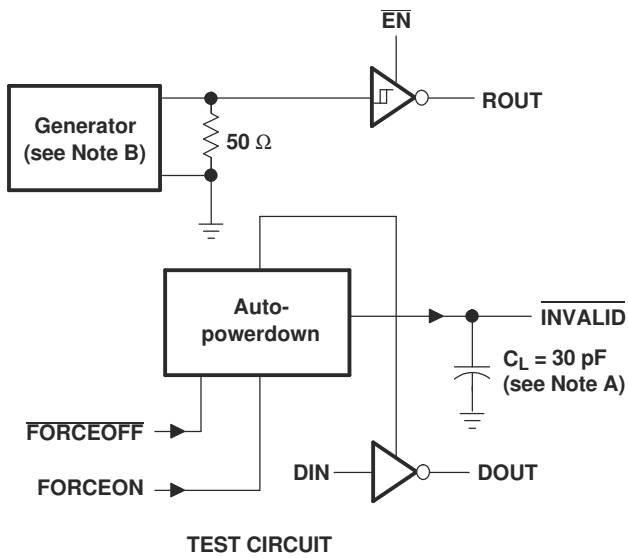

† Auto-powerdown disables drivers and reduces supply current to 1 μ A

- A. C_L includes probe and jig capacitance.
- B. The pulse generator has the following characteristics: PRR = 250 kbit/s, $Z_O = 50 \Omega$, 50% duty cycle, $t_r \leq 10$ ns, $t_f \leq 10$ ns.

Figure 5-5. $\overline{\text{INVALID}}$ Propagation Delay Times and Supply Enabling Time

6 Detailed Description

6.1 Functional Block Diagram

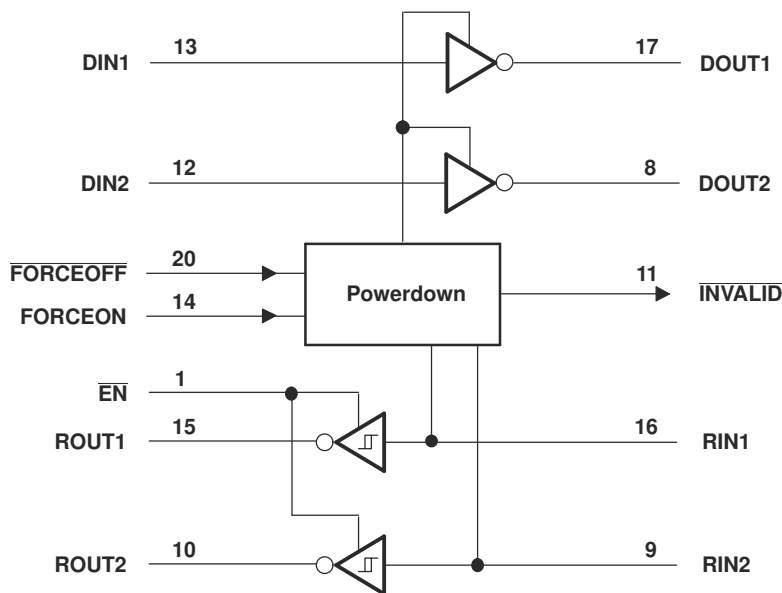

Pin numbers are for the DB, DW, and PW packages.

Figure 6-1. Logic diagram (positive logic)

6.2 Device Functional Modes

Function Table (Each Driver)

INPUTS ⁽¹⁾				OUTPUT DOUT	DRIVER STATUS
DIN	FORCEON	FORCEOFF	VALID RIN RS-232 LEVEL		
X	X	L	X	Z	Powered off
L	H	H	X	H	Normal operation with auto-powerdown disabled
H	H	H	X	L	
L	L	H	Yes	H	Normal operation with auto-powerdown enabled
H	L	H	Yes	L	
L	L	H	No	Z	Powered off by auto-powerdown feature
H	L	H	No	Z	

(1) H = high level, L = low level, X = irrelevant, Z = high impedance

Function Table (Each Receiver)

INPUTS ⁽¹⁾			OUTPUT DOUT
RIN	EN	VALID RIN RS-232 LEVEL	
L	L	X	H
H	L	X	L
X	H	X	Z
Open	L	No	H

(1) H = high level, L = low level, X = irrelevant, Z = high impedance (off), Open = input disconnected or connected driver off

7 Application and Implementation

Note

Information in the following applications sections is not part of the TI component specification, and TI does not warrant its accuracy or completeness. TI's customers are responsible for determining suitability of components for their purposes, as well as validating and testing their design implementation to confirm system functionality.

7.1 Typical Application

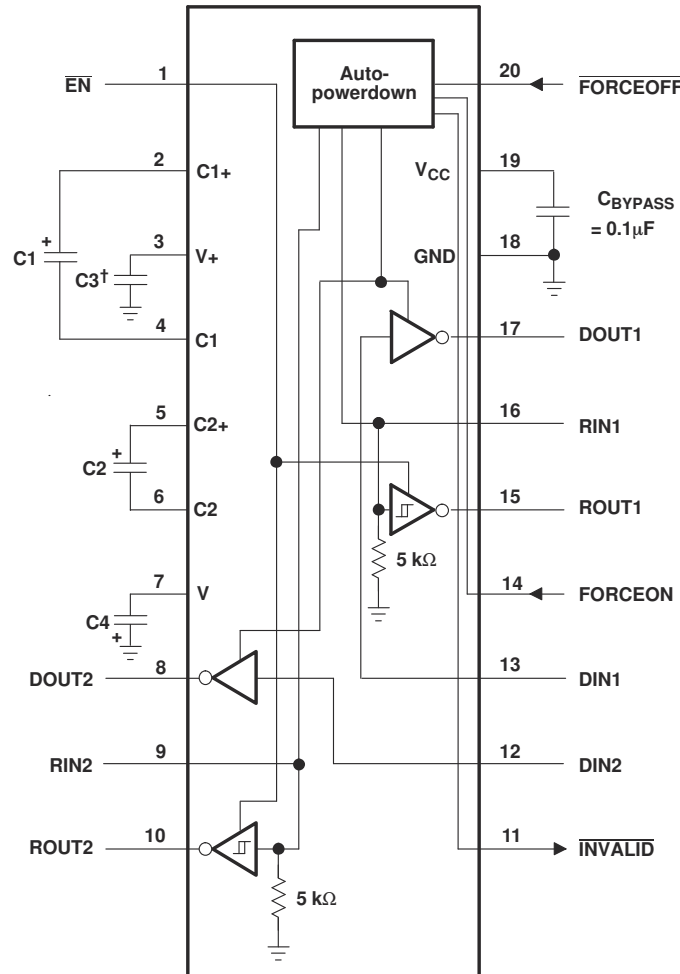

† C3 can be connected to V_{CC} or GND.

NOTES: A. Resistor values shown are nominal.

B. Nonpolarized ceramic capacitors are acceptable. If polarized tantalum or electrolytic capacitors are used, they should be connected as shown.

V_{CC} vs CAPACITOR VALUES

V_{CC}	C1	C2, C3, and C4
3.3 V ± 0.3 V	0.1 μ F	0.1 μ F
5 V ± 0.5 V	0.047 μ F	0.33 μ F
3 V to 5.5 V	0.1 μ F	0.47 μ F

Figure 7-1. Typical Operating Circuit and Capacitor Values

7.1.1 Detailed Design Procedure

MAX3223E has integrated charge-pump that generates positive and negative rails needed for RS-232 signal levels. Main design requirement is that charge-pump capacitor terminals must be connected with recommended capacitor values. Charge-pump rail voltages and device supply pin must be properly bypassed with ceramic capacitors

(1)

8 Device and Documentation Support

8.1 Receiving Notification of Documentation Updates

To receive notification of documentation updates, navigate to the device product folder on ti.com. Click on *Subscribe to updates* to register and receive a weekly digest of any product information that has changed. For change details, review the revision history included in any revised document.

8.2 Support Resources

[TI E2E™ support forums](#) are an engineer's go-to source for fast, verified answers and design help — straight from the experts. Search existing answers or ask your own question to get the quick design help you need.

Linked content is provided "AS IS" by the respective contributors. They do not constitute TI specifications and do not necessarily reflect TI's views; see TI's [Terms of Use](#).

8.3 Trademarks

TI E2E™ is a trademark of Texas Instruments.
All trademarks are the property of their respective owners.

8.4 Electrostatic Discharge Caution



This integrated circuit can be damaged by ESD. Texas Instruments recommends that all integrated circuits be handled with appropriate precautions. Failure to observe proper handling and installation procedures can cause damage.

ESD damage can range from subtle performance degradation to complete device failure. Precision integrated circuits may be more susceptible to damage because very small parametric changes could cause the device not to meet its published specifications.

8.5 Glossary

[TI Glossary](#) This glossary lists and explains terms, acronyms, and definitions.

9 Revision History

NOTE: Page numbers for previous revisions may differ from page numbers in the current version.

Changes from Revision A (September 2009) to Revision B (December 2023)	Page
• Changed the numbering format for tables, figures, and cross-references throughout the document.....	1
• Added the <i>ESD Ratings</i> tables.....	3
• Added the <i>Thermal Information</i> table.....	4
• Changed the I _{CC} Auto-powerdown disabled max value from 1 mA to 1.3 mA in the <i>Electrical Characteristics</i>	4

Changes from Revision * (January 2006) to Revision A (September 2009)	Page
• Deleted the <i>RHL Pinout</i> image.....	1

10 Mechanical, Packaging, and Orderable Information

The following pages include mechanical, packaging, and orderable information. This information is the most current data available for the designated devices. This data is subject to change without notice and revision of this document. For browser-based versions of this data sheet, refer to the left-hand navigation.

PACKAGING INFORMATION

Orderable part number	Status (1)	Material type (2)	Package Pins	Package qty Carrier	RoHS (3)	Lead finish/ Ball material (4)	MSL rating/ Peak reflow (5)	Op temp (°C)	Part marking (6)
MAX3223ECDBR	Obsolete	Production	SSOP (DB) 20	-	-	Call TI	Call TI	0 to 70	MP223EC
MAX3223ECDW	Active	Production	SOIC (DW) 20	25 TUBE	Yes	NIPDAU	Level-1-260C-UNLIM	0 to 70	MAX3223EC
MAX3223ECDW.A	Active	Production	SOIC (DW) 20	25 TUBE	Yes	NIPDAU	Level-1-260C-UNLIM	0 to 70	MAX3223EC
MAX3223ECDWR	Active	Production	SOIC (DW) 20	2000 LARGE T&R	Yes	NIPDAU	Level-1-260C-UNLIM	0 to 70	MAX3223EC
MAX3223ECDWR.A	Active	Production	SOIC (DW) 20	2000 LARGE T&R	Yes	NIPDAU	Level-1-260C-UNLIM	0 to 70	MAX3223EC
MAX3223ECPW	Obsolete	Production	TSSOP (PW) 20	-	-	Call TI	Call TI	0 to 70	MP223EC
MAX3223ECPWR	Obsolete	Production	TSSOP (PW) 20	-	-	Call TI	Call TI	0 to 70	MP223EC
MAX3223EIDB	Obsolete	Production	SSOP (DB) 20	-	-	Call TI	Call TI	-40 to 85	MP223EI
MAX3223EIDBR	Active	Production	SSOP (DB) 20	2000 LARGE T&R	Yes	NIPDAU	Level-1-260C-UNLIM	-40 to 85	MP223EI
MAX3223EIDBR.A	Active	Production	SSOP (DB) 20	2000 LARGE T&R	Yes	NIPDAU	Level-1-260C-UNLIM	-40 to 85	MP223EI
MAX3223EIDBRG4	Active	Production	SSOP (DB) 20	2000 LARGE T&R	Yes	NIPDAU	Level-1-260C-UNLIM	-40 to 85	MP223EI
MAX3223EIDBRG4.A	Active	Production	SSOP (DB) 20	2000 LARGE T&R	Yes	NIPDAU	Level-1-260C-UNLIM	-40 to 85	MP223EI
MAX3223EIDW	Active	Production	SOIC (DW) 20	25 TUBE	Yes	NIPDAU	Level-1-260C-UNLIM	-40 to 85	MAX3223EI
MAX3223EIDW.A	Active	Production	SOIC (DW) 20	25 TUBE	Yes	NIPDAU	Level-1-260C-UNLIM	-40 to 85	MAX3223EI
MAX3223EIDWR	Active	Production	SOIC (DW) 20	2000 LARGE T&R	Yes	NIPDAU	Level-1-260C-UNLIM	-40 to 85	MAX3223EI
MAX3223EIDWR.A	Active	Production	SOIC (DW) 20	2000 LARGE T&R	Yes	NIPDAU	Level-1-260C-UNLIM	-40 to 85	MAX3223EI
MAX3223EIPWR	Active	Production	TSSOP (PW) 20	2000 LARGE T&R	Yes	NIPDAU NIPDAU	Level-1-260C-UNLIM	-40 to 85	MP223EI
MAX3223EIPWR.A	Active	Production	TSSOP (PW) 20	2000 LARGE T&R	Yes	NIPDAU	Level-1-260C-UNLIM	-40 to 85	MP223EI

(1) **Status:** For more details on status, see our [product life cycle](#).

(2) **Material type:** When designated, preproduction parts are prototypes/experimental devices, and are not yet approved or released for full production. Testing and final process, including without limitation quality assurance, reliability performance testing, and/or process qualification, may not yet be complete, and this item is subject to further changes or possible discontinuation. If available for ordering, purchases will be subject to an additional waiver at checkout, and are intended for early internal evaluation purposes only. These items are sold without warranties of any kind.

(3) **RoHS values:** Yes, No, RoHS Exempt. See the [TI RoHS Statement](#) for additional information and value definition.

(4) **Lead finish/Ball material:** Parts may have multiple material finish options. Finish options are separated by a vertical ruled line. Lead finish/Ball material values may wrap to two lines if the finish value exceeds the maximum column width.

(5) **MSL rating/Peak reflow:** The moisture sensitivity level ratings and peak solder (reflow) temperatures. In the event that a part has multiple moisture sensitivity ratings, only the lowest level per JEDEC standards is shown. Refer to the shipping label for the actual reflow temperature that will be used to mount the part to the printed circuit board.

(6) **Part marking:** There may be an additional marking, which relates to the logo, the lot trace code information, or the environmental category of the part.

Multiple part markings will be inside parentheses. Only one part marking contained in parentheses and separated by a "~" will appear on a part. If a line is indented then it is a continuation of the previous line and the two combined represent the entire part marking for that device.

Important Information and Disclaimer:The information provided on this page represents TI's knowledge and belief as of the date that it is provided. TI bases its knowledge and belief on information provided by third parties, and makes no representation or warranty as to the accuracy of such information. Efforts are underway to better integrate information from third parties. TI has taken and continues to take reasonable steps to provide representative and accurate information but may not have conducted destructive testing or chemical analysis on incoming materials and chemicals. TI and TI suppliers consider certain information to be proprietary, and thus CAS numbers and other limited information may not be available for release.

In no event shall TI's liability arising out of such information exceed the total purchase price of the TI part(s) at issue in this document sold by TI to Customer on an annual basis.

TAPE AND REEL INFORMATION

QUADRANT ASSIGNMENTS FOR PIN 1 ORIENTATION IN TAPE



*All dimensions are nominal

Device	Package Type	Package Drawing	Pins	SPQ	Reel Diameter (mm)	Reel Width W1 (mm)	A0 (mm)	B0 (mm)	K0 (mm)	P1 (mm)	W (mm)	Pin1 Quadrant
MAX3223ECDWR	SOIC	DW	20	2000	330.0	24.4	10.8	13.3	2.7	12.0	24.0	Q1
MAX3223EIDBR	SSOP	DB	20	2000	330.0	16.4	8.2	7.5	2.5	12.0	16.0	Q1
MAX3223EIDBR	SSOP	DB	20	2000	330.0	16.4	8.2	7.5	2.5	12.0	16.0	Q1
MAX3223EIDBRG4	SSOP	DB	20	2000	330.0	16.4	8.2	7.5	2.5	12.0	16.0	Q1
MAX3223EIDBRG4	SSOP	DB	20	2000	330.0	16.4	8.2	7.5	2.5	12.0	16.0	Q1
MAX3223EIDWR	SOIC	DW	20	2000	330.0	24.4	10.8	13.3	2.7	12.0	24.0	Q1
MAX3223EIPWR	TSSOP	PW	20	2000	330.0	16.4	6.95	7.1	1.6	8.0	16.0	Q1
MAX3223EIPWR	TSSOP	PW	20	2000	330.0	16.4	6.95	7.0	1.4	8.0	16.0	Q1

TAPE AND REEL BOX DIMENSIONS

*All dimensions are nominal

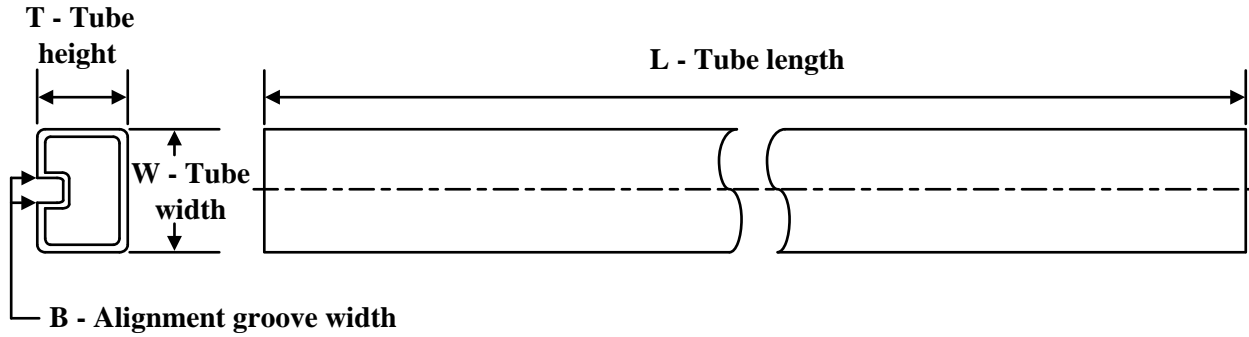
Device	Package Type	Package Drawing	Pins	SPQ	Length (mm)	Width (mm)	Height (mm)
MAX3223ECDWR	SOIC	DW	20	2000	367.0	367.0	45.0
MAX3223EIDBR	SSOP	DB	20	2000	353.0	353.0	32.0
MAX3223EIDBR	SSOP	DB	20	2000	356.0	356.0	35.0
MAX3223EIDBRG4	SSOP	DB	20	2000	356.0	356.0	35.0
MAX3223EIDBRG4	SSOP	DB	20	2000	353.0	353.0	32.0
MAX3223EIDWR	SOIC	DW	20	2000	367.0	367.0	45.0
MAX3223EIPWR	TSSOP	PW	20	2000	353.0	353.0	32.0
MAX3223EIPWR	TSSOP	PW	20	2000	356.0	356.0	35.0

TUBE

*All dimensions are nominal

Device	Package Name	Package Type	Pins	SPQ	L (mm)	W (mm)	T (μm)	B (mm)
MAX3223ECDW	DW	SOIC	20	25	507	12.83	5080	6.6
MAX3223ECDW.A	DW	SOIC	20	25	507	12.83	5080	6.6
MAX3223EIDW	DW	SOIC	20	25	507	12.83	5080	6.6
MAX3223EIDW.A	DW	SOIC	20	25	507	12.83	5080	6.6

PW0020A



PACKAGE OUTLINE

TSSOP - 1.2 mm max height

SMALL OUTLINE PACKAGE



4220206/A 02/2017

NOTES:

- All linear dimensions are in millimeters. Any dimensions in parenthesis are for reference only. Dimensioning and tolerancing per ASME Y14.5M.
- This drawing is subject to change without notice.
- This dimension does not include mold flash, protrusions, or gate burrs. Mold flash, protrusions, or gate burrs shall not exceed 0.15 mm per side.
- This dimension does not include interlead flash. Interlead flash shall not exceed 0.25 mm per side.
- Reference JEDEC registration MO-153.

EXAMPLE BOARD LAYOUT

PW0020A

TSSOP - 1.2 mm max height

SMALL OUTLINE PACKAGE



LAND PATTERN EXAMPLE
EXPOSED METAL SHOWN
SCALE: 10X



SOLDER MASK DETAILS

4220206/A 02/2017

NOTES: (continued)

- 6. Publication IPC-7351 may have alternate designs.
- 7. Solder mask tolerances between and around signal pads can vary based on board fabrication site.

EXAMPLE STENCIL DESIGN

PW0020A

TSSOP - 1.2 mm max height

SMALL OUTLINE PACKAGE



SOLDER PASTE EXAMPLE
BASED ON 0.125 mm THICK STENCIL
SCALE: 10X

4220206/A 02/2017

NOTES: (continued)

8. Laser cutting apertures with trapezoidal walls and rounded corners may offer better paste release. IPC-7525 may have alternate design recommendations.
9. Board assembly site may have different recommendations for stencil design.

DB0020A



PACKAGE OUTLINE

SSOP - 2 mm max height

SMALL OUTLINE PACKAGE



4214851/B 08/2019

NOTES:

- All linear dimensions are in millimeters. Any dimensions in parenthesis are for reference only. Dimensioning and tolerancing per ASME Y14.5M.
- This drawing is subject to change without notice.
- This dimension does not include mold flash, protrusions, or gate burrs. Mold flash, protrusions, or gate burrs shall not exceed 0.15 mm per side.
- This dimension does not include interlead flash. Interlead flash shall not exceed 0.25 mm per side.
- Reference JEDEC registration MO-150.

EXAMPLE BOARD LAYOUT

DB0020A

SSOP - 2 mm max height

SMALL OUTLINE PACKAGE



LAND PATTERN EXAMPLE
EXPOSED METAL SHOWN
SCALE: 10X



4214851/B 08/2019

NOTES: (continued)

- 6. Publication IPC-7351 may have alternate designs.
- 7. Solder mask tolerances between and around signal pads can vary based on board fabrication site.

EXAMPLE STENCIL DESIGN

DB0020A

SSOP - 2 mm max height

SMALL OUTLINE PACKAGE



SOLDER PASTE EXAMPLE
BASED ON 0.125 mm THICK STENCIL
SCALE: 10X

4214851/B 08/2019

NOTES: (continued)

8. Laser cutting apertures with trapezoidal walls and rounded corners may offer better paste release. IPC-7525 may have alternate design recommendations.
9. Board assembly site may have different recommendations for stencil design.

DW0020A



PACKAGE OUTLINE

SOIC - 2.65 mm max height

SOIC



4220724/A 05/2016

NOTES:

1. All linear dimensions are in millimeters. Dimensions in parenthesis are for reference only. Dimensioning and tolerancing per ASME Y14.5M.
2. This drawing is subject to change without notice.
3. This dimension does not include mold flash, protrusions, or gate burrs. Mold flash, protrusions, or gate burrs shall not exceed 0.15 mm per side.
4. This dimension does not include interlead flash. Interlead flash shall not exceed 0.43 mm per side.
5. Reference JEDEC registration MS-013.

EXAMPLE BOARD LAYOUT

DW0020A

SOIC - 2.65 mm max height

SOIC



LAND PATTERN EXAMPLE
SCALE:6X



SOLDER MASK DETAILS

4220724/A 05/2016

NOTES: (continued)

- 6. Publication IPC-7351 may have alternate designs.
- 7. Solder mask tolerances between and around signal pads can vary based on board fabrication site.

EXAMPLE STENCIL DESIGN

DW0020A

SOIC - 2.65 mm max height

SOIC



SOLDER PASTE EXAMPLE
BASED ON 0.125 mm THICK STENCIL
SCALE:6X

4220724/A 05/2016

NOTES: (continued)

8. Laser cutting apertures with trapezoidal walls and rounded corners may offer better paste release. IPC-7525 may have alternate design recommendations.
9. Board assembly site may have different recommendations for stencil design.

IMPORTANT NOTICE AND DISCLAIMER

TI PROVIDES TECHNICAL AND RELIABILITY DATA (INCLUDING DATA SHEETS), DESIGN RESOURCES (INCLUDING REFERENCE DESIGNS), APPLICATION OR OTHER DESIGN ADVICE, WEB TOOLS, SAFETY INFORMATION, AND OTHER RESOURCES "AS IS" AND WITH ALL FAULTS, AND DISCLAIMS ALL WARRANTIES, EXPRESS AND IMPLIED, INCLUDING WITHOUT LIMITATION ANY IMPLIED WARRANTIES OF MERCHANTABILITY, FITNESS FOR A PARTICULAR PURPOSE OR NON-INFRINGEMENT OF THIRD PARTY INTELLECTUAL PROPERTY RIGHTS.

These resources are intended for skilled developers designing with TI products. You are solely responsible for (1) selecting the appropriate TI products for your application, (2) designing, validating and testing your application, and (3) ensuring your application meets applicable standards, and any other safety, security, regulatory or other requirements.

These resources are subject to change without notice. TI grants you permission to use these resources only for development of an application that uses the TI products described in the resource. Other reproduction and display of these resources is prohibited. No license is granted to any other TI intellectual property right or to any third party intellectual property right. TI disclaims responsibility for, and you will fully indemnify TI and its representatives against, any claims, damages, costs, losses, and liabilities arising out of your use of these resources.

TI's products are provided subject to [TI's Terms of Sale](#) or other applicable terms available either on [ti.com](https://www.ti.com) or provided in conjunction with such TI products. TI's provision of these resources does not expand or otherwise alter TI's applicable warranties or warranty disclaimers for TI products.

TI objects to and rejects any additional or different terms you may have proposed.

Mailing Address: Texas Instruments, Post Office Box 655303, Dallas, Texas 75265
Copyright © 2025, Texas Instruments Incorporated