

XTR200 Precision, 3-Wire, Current-and-Voltage Transmitter

1 Features

- Mode pin for selectable current or voltage output
 - Current output transfer function set by a single external resistor
 - Voltage output mode has a fixed gain of 3.75V/V
- Integrated output transistor eliminates external components
- Capable of output voltages within 1mV of ground on a single supply
- Wide supply voltage range: 8V to 60V
- Wide specified temperature range: -40°C to +125°C
- Low input offset voltage: ±200µV
- Low input offset voltage drift: ±0.5µV/°C
- Excellent span error (current mode): 0.01%
- Excellent gain error (voltage mode): 0.01%
- Output error flag (\overline{EF})
- Output disable (OD)
- Extremely small 3mm × 2mm WSON package

2 Applications

- [Position sensor](#)
- [Pressure transmitter](#)
- [Temperature transmitter](#)
- [Flow transmitter](#)
- [Analog output module](#)
- [AC drive control module](#)
- [CPU \(PLC controller\)](#)
- [HVAC valve and actuator control](#)
- Constant-current sensor biasing
- Resistance Temperature Detector (RTD) biasing
- High-side current source

3 Description

The XTR200 is a high-voltage, precision, output driver for 3-wire current or voltage systems, designed for standard industrial signal levels such as 0mA to 20mA, 4mA to 20mA, and 0V to 10V. The mode pin configures the device for either current or voltage output and eliminates the need to change external components to switch between modes. In current-output mode, the ratio between input voltage and output current is set by a single resistor, R_{SET} . In voltage-output mode, the XTR200 has a fixed gain of 3.75V/V which is set by integrated, high-precision, thin-film, resistors.

The device integrates a low-leakage PMOS output transistor and short-circuit current protection, further reducing the need for external components. An external PNP or PMOS transistor can be used with the XTR200 to reduce on-chip power dissipation. The on-chip short-circuit protection also protects external transistors from damaging overcurrent events.

The XTR200 error flag pin (\overline{EF}) indicates several temperature or output fault conditions. The output disable pin (OD) places the output pin into a high-impedance state with very low leakage.

The XTR200 is available in a small 3mm × 2mm, 10-pin WSON surface-mount package.

Package Information

PART NUMBER	PACKAGE ⁽¹⁾	PACKAGE SIZE ⁽²⁾
XTR200	DQC (WSON, 10)	3mm × 2mm

(1) For more information, see [Section 10](#).

(2) The package size (length × width) is a nominal value and includes pins, where applicable.

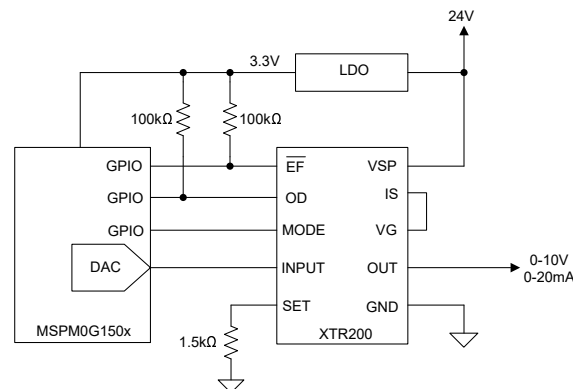

Simplified Schematic of XTR200 Used in a Three-Wire Output Circuit



Table of Contents

1 Features	1	7 Application and Implementation	15
2 Applications	1	7.1 Application Information.....	15
3 Description	1	7.2 Typical Applications.....	18
4 Pin Configurations and Functions	3	7.3 Power Supply Recommendations.....	20
5 Specifications	4	7.4 Layout.....	21
5.1 Absolute Maximum Ratings.....	4	8 Device and Documentation Support	22
5.2 ESD Ratings.....	4	8.1 Device Support.....	22
5.3 Recommended Operating Conditions.....	4	8.2 Documentation Support.....	22
5.4 Thermal Information.....	4	8.3 Receiving Notification of Documentation Updates....	22
5.5 Electrical Characteristics.....	5	8.4 Support Resources.....	22
5.6 Typical Characteristics.....	7	8.5 Trademarks.....	22
6 Detailed Description	9	8.6 Electrostatic Discharge Caution.....	22
6.1 Overview.....	9	8.7 Glossary.....	22
6.2 Functional Block Diagram.....	9	9 Revision History	22
6.3 Feature Description.....	10	10 Mechanical, Packaging, and Orderable Information	23
6.4 Device Functional Modes.....	12		

4 Pin Configurations and Functions

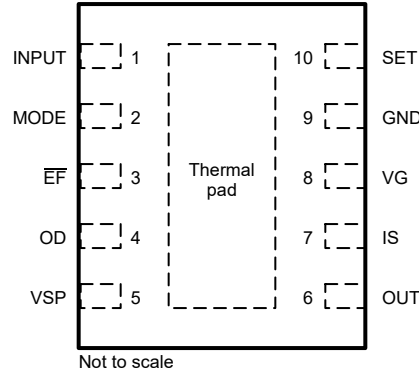

DQC Package, 10-Pin WSON (Top View)

Table 4-1. Pin Functions

PIN		TYPE	DESCRIPTION
NO.	NAME		
1	INPUT	Input	Input voltage
2	MODE	Input	Selects current output mode (high) or voltage output mode (low)
3	EF	Output	Error flag (active low)
4	OD	Input	Output disable (active high)
5	VSP	Power	Positive supply
6	OUT	Output	Output current or voltage signal
7	IS	Output	Source or emitter connection for optional external transistor
8	VG	Output	Gate or base drive for optional external transistor
9	GND	Ground	Negative supply
10	SET	Input	Sets the voltage-to-current transfer ratio
Pad	Thermal pad	—	Connect exposed thermal pad to GND

5 Specifications

5.1 Absolute Maximum Ratings

over operating free-air temperature range (unless otherwise noted) ⁽¹⁾

		MIN	MAX	UNIT
V+	Power supply (referenced to GND pin)		65	V
	Input voltage (referenced to GND pin)	0	6	V
	Output current limit		Continuous	
T _A	Operating junction temperature	-50	150	°C
	Specified temperature	-40	125	°C
T _{stg}	Storage temperature	-55	125	°C
	Lead temperature (soldering, 10s)		300	°C

- (1) Stresses beyond those listed under *Absolute Maximum Ratings* may cause permanent damage to the device. These are stress ratings only, which do not imply functional operation of the device at these or any other conditions beyond those indicated under *Recommended Operating Conditions*. Exposure to absolute-maximum-rated conditions for extended periods may affect device reliability.

5.2 ESD Ratings

			VALUE	UNIT
V _(ESD)	Electrostatic discharge	Human-body model (HBM), per ANSI/ESDA/JEDEC JS-001 ⁽¹⁾	TBD	V
		Charged-device model (CDM), per ANSI/ESDA/JEDEC JS-002 ⁽²⁾	TBD	

- (1) JEDEC document JEP155 states that 500V HBM allows safe manufacturing with a standard ESD control process.
 (2) JEDEC document JEP157 states that 250V CDM allows safe manufacturing with a standard ESD control process.

5.3 Recommended Operating Conditions

over operating free-air temperature range (unless otherwise noted)

	MIN	NOM	MAX	UNIT
Supply voltage, V _s = (V+) – (V–)	8	24	60	V
Specified temperature	-40		125	°C

5.4 Thermal Information

THERMAL METRIC ⁽¹⁾		XTR200	UNIT
		10 PINS	
		DQC (DFN-10)	
R _{θJA}	Junction-to-ambient thermal resistance	69.4	°C/W
R _{θJC(top)}	Junction-to-case (top) thermal resistance	71.2	°C/W
R _{θJC(bot)}	Junction-to-case (bottom) thermal resistance	13.9	°C/W
R _{θJB}	Junction-to-board thermal resistance	36.7	°C/W
ψ _{JT}	Junction-to-top characterization parameter	3.1	°C/W
ψ _{JB}	Junction-to-board characterization parameter	36.6	°C/W

- (1) For more information about traditional and new thermal metrics, see the [Semiconductor and IC Package Thermal Metrics application note](#).

5.5 Electrical Characteristics

at $T_A = 25^\circ\text{C}$, $V_{SP} = 24\text{V}$, Current-Output Mode: $R_{SET} = 1.5\text{k}\Omega$, $R_L = 250\Omega$, $C_L = 10\text{pF}$, Voltage-Output Mode: $R_L = 1\text{k}\Omega$, $C_L = 10\text{pF}$ unless otherwise noted.

PARAMETER		TEST CONDITIONS		MIN	TYP	MAX	UNIT
INPUT							
	Input voltage range			0		5	V
V_{OS}	Input offset voltage				± 200	± 800	μV
		$T_A = -40^\circ\text{C}$ to $+125^\circ\text{C}$				± 1000	
dV_{OS}/dT	Input offset voltage drift	$T_A = -40^\circ\text{C}$ to $+125^\circ\text{C}$			± 0.5	± 2	$\mu\text{V}/^\circ\text{C}$
PSRR	Power supply rejection ratio				2	8	$\mu\text{V}/\text{V}$
		$T_A = -40^\circ\text{C}$ to $+125^\circ\text{C}$				10	
I_B	Input bias current	$V_{IN} = 3\text{V}$			± 25		pA
		$T_A = -40^\circ\text{C}$ to $+125^\circ\text{C}$				10	nA
Z_{IN}	Input impedance				$1 \parallel 1$		$\text{T}\Omega \parallel \text{pF}$
e_n	Input voltage noise density	$f = 1\text{kHz}$	Current-output mode		53		$\text{nV}/\sqrt{\text{Hz}}$
			Voltage-output mode		34		
	Input voltage noise	$f = 0.1\text{Hz}$ to 10Hz	Current-output mode		10		$\mu\text{Vp-p}$
			Voltage-output mode		6.5		
I_n	Input current noise density	$f = 1\text{kHz}$			3		$\text{fA}/\sqrt{\text{Hz}}$
CURRENT OUTPUT							
I_{OUT}	Output current equation	$I_{OUT} = 10 * (V_{IN} / R_{SET})$					
	Output current headroom				2.5		V
	Output current, linear range			0.01		25	mA
R_O	Output resistance				1		$\text{G}\Omega$
I_{LEAK}	Output leakage	Output Disabled			10		nA
		$T_A = -40^\circ\text{C}$ to $+125^\circ\text{C}$				50	
dI_O/dT	Output current drift	$T_A = -40^\circ\text{C}$ to $+125^\circ\text{C}$	$I_{OUT} = 4\text{mA}$		6	25	$\text{nA}/^\circ\text{C}$
			$I_{OUT} = 20\text{mA}$		15	65	
	Nonlinearity	I_{OUT} from 0.1mA to 25mA			0.001%	0.003%	
	Span error	I_{OUT} from 0.1mA to 25mA			0.01%	0.065%	$\%/\text{V}$
		$T_A = -40^\circ\text{C}$ to $+125^\circ\text{C}$				0.07%	
		V_{SP} from 12V to 40V			0.0001	0.0003	
	Span error drift	$T_A = -40^\circ\text{C}$ to $+125^\circ\text{C}$			1	2	$\text{ppm}/^\circ\text{C}$
I_{OS}	Offset current	$V_{IN} = 0\text{V}$			2	10	μA
		$I_{OUT} = 4\text{mA}$			2	12	
		$T_A = -40^\circ\text{C}$ to $+125^\circ\text{C}$				TBD	
dI_{OS}/dV_S	Offset current vs supply	$I_{OUT} = 4\text{mA}$	V_{SP} from 8V to 40V		5	70	nA/V
VOLTAGE OUTPUT							
V_{OUT}	Output voltage equation	$V_{OUT} = V_{IN} * 3.75$					
	Output voltage headroom	$V_{SP} = 8\text{V}$	$I_{OUT} = 20\text{mA}$		2.5		V
	Maximum output voltage	$V_{IN} = 5\text{V}$			18.75		V
	Minimum output voltage	$V_{IN} = 0\text{V}$			1	3	mV
		$T_A = -40^\circ\text{C}$ to $+125^\circ\text{C}$				4	
	Gain error	V_{OUT} from 10 mV to 10 V			0.01%	0.04%	
		$T_A = -40^\circ\text{C}$ to $+125^\circ\text{C}$				0.05%	
		V_{SP} from 12.5V to 40V			TBD		
	Gain error drift	$T_A = -40^\circ\text{C}$ to $+125^\circ\text{C}$			0.1	0.2	$\text{ppm}/^\circ\text{C}$
	Nonlinearity	V_{OUT} from 10mV to 10V			0.0025%	0.034%	
I_{LIM}	Short circuit current limit				30	45	mA
		$T_A = -40^\circ\text{C}$ to $+125^\circ\text{C}$				49	

5.5 Electrical Characteristics (continued)

at $T_A = 25^\circ\text{C}$, $V_{SP} = 24\text{V}$, Current-Output Mode: $R_{SET} = 1.5\text{k}\Omega$, $R_L = 250\Omega$, $C_L = 10\text{pF}$, Voltage-Output Mode: $R_L = 1\text{k}\Omega$, $C_L = 10\text{pF}$ unless otherwise noted.

PARAMETER		TEST CONDITIONS	MIN	TYP	MAX	UNIT
DYNAMIC RESPONSE						
	Small signal bandwidth	Current-output mode		2.8		MHz
		Voltage-output mode		250		kHz
	Slew rate	Current-output mode		2.5		mA/ μs
		Voltage-output mode		0.5		V/ μs
ERROR FLAG						
	Output voltage	Logic Low			0.8	V
		Logic High	2	3.3		V
	Thermal warning temperature	EF Output Low	125	130	135	$^\circ\text{C}$
MODE						
	Input logic threshold (high)	Current-output mode	2			V
	Input logic threshold (low)	Voltage-output mode			0.8	V
	Internal pull-up current			4		μA
OUTPUT DISABLE						
	Input logic threshold (high)	Output Disabled	2			V
	Input logic threshold (low)	Output Enabled			0.8	V
	Internal pullup current			4		μA
POWER SUPPLY						
I_Q	Quiescent current	Current-output mode		325	450	μA
		$T_A = -40^\circ\text{C}$ to 125°C			550	

5.6 Typical Characteristics

at $T_A = 25^\circ\text{C}$ and $V_{SP} = 24\text{V}$ (unless otherwise noted)

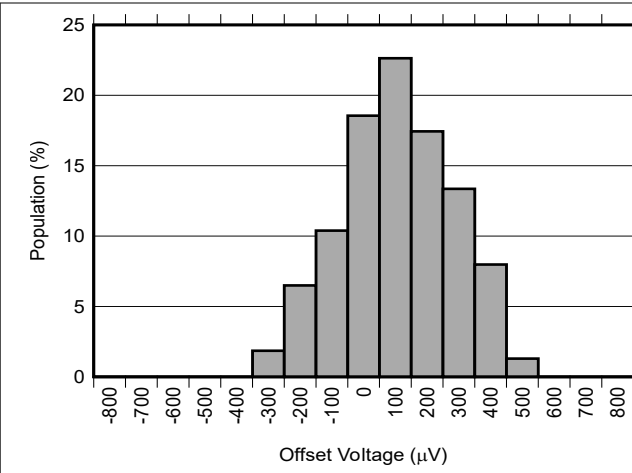

Figure 5-1. Offset Voltage Distribution

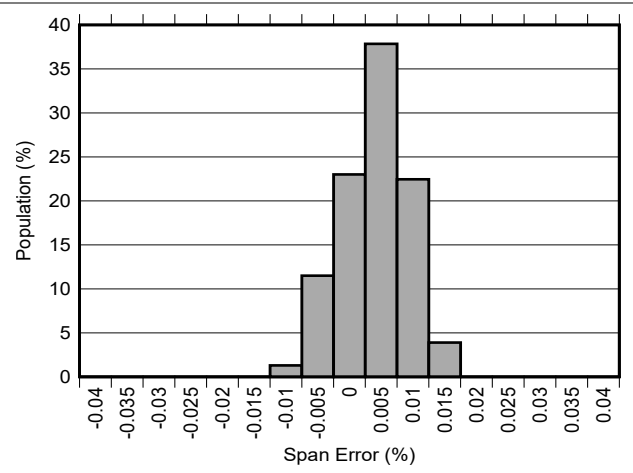

Figure 5-2. Span Error Distribution

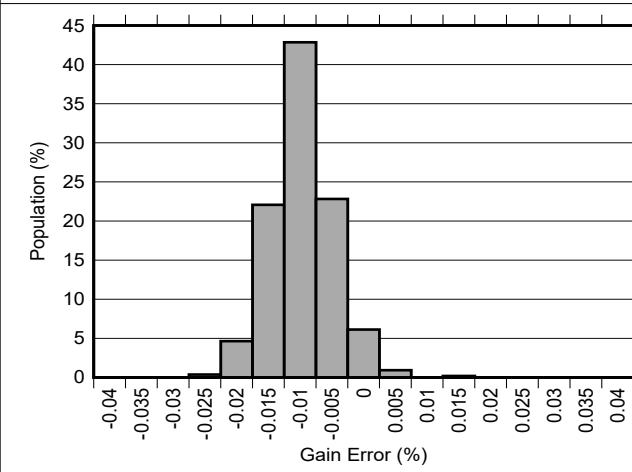

Figure 5-3. Gain Error Distribution

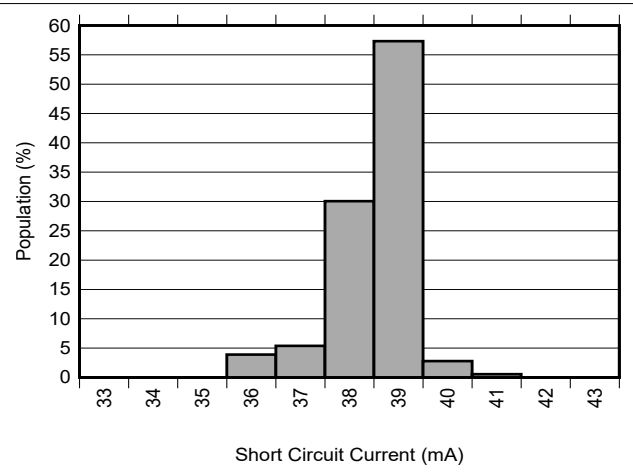

Figure 5-4. Short-Circuit Current Limit Distribution

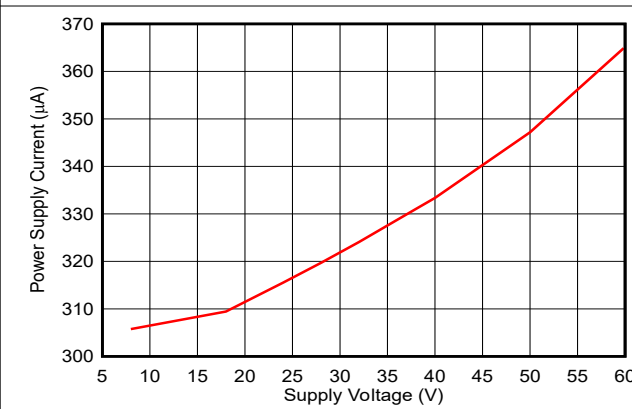

Figure 5-5. Power Supply Current vs Supply Voltage

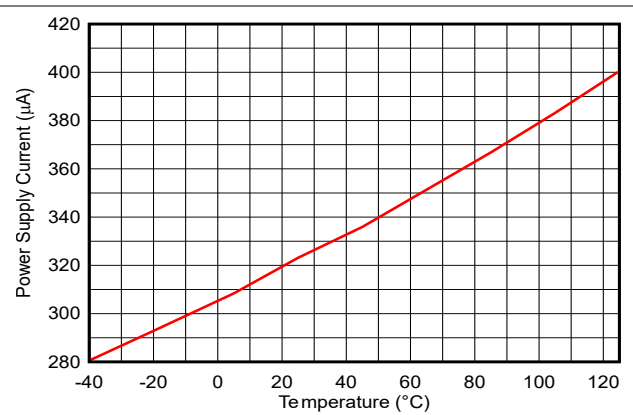

Figure 5-6. Power Supply Current vs Temperature

5.6 Typical Characteristics (continued)

at $T_A = 25^\circ\text{C}$ and $V_{SP} = 24\text{V}$ (unless otherwise noted)

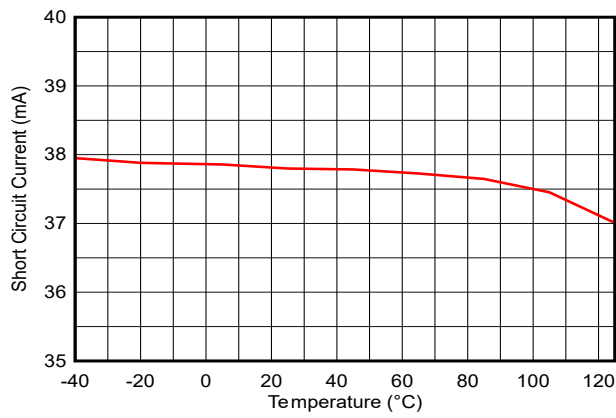

Figure 5-7. Short-Circuit Current vs Temperature

6 Detailed Description

6.1 Overview

The XTR200 is an output driver intended for 3-wire systems with analog current or voltage outputs. The XTR200 is designed to deliver the commonly-used industrial signaling ranges of 0mA to 20mA, 4mA to 20mA, or 0V to 10V on a single supply and with minimal additional components. The performance is specified for a nominal supply voltage of 24V, but sustained supply voltages up to 60V are acceptable, with an absolute maximum supply voltage rating of 65V. Furthermore, the XTR200 is specified over the full industrial temperature range of -40°C to $+125^{\circ}\text{C}$.

The XTR200 has two modes of normal operation. In current-output mode, the voltage-to-current ratio is defined by an external resistor, R_{SET} ; therefore, the input voltage range can be freely set in accordance with application requirements. In voltage-output mode, the XTR200 has a fixed gain of 3.75V/V, which produces a 0V to 10V output from a 0V to 2.67V input voltage achievable by many common digital-to-analog converters (DACs) and microcontrollers.

Error detection circuitry activates a logic output (error flag pin, $\overline{\text{EF}}$) in case the correct current or voltage output is unachievable, the die temperature is too high, or the power supply voltage is too low. Use the output disable (OD) pin during power-on, multiplexing, and other conditions where the output presents no current. The OD pin contains an internal pullup that causes the XTR200 to come up in output disable mode unless the OD pin is tied low.

The XTR200 integrates an output PMOS capable of driving the full rated load current across a wide range of supply voltages. However, the device can also be configured to use an external PNP or PMOS transistor to deliver the majority of the load current and reduce the on-chip power dissipation. Both the internal PMOS and optional external transistors are protected by integrated short circuit protection circuitry.

6.2 Functional Block Diagram

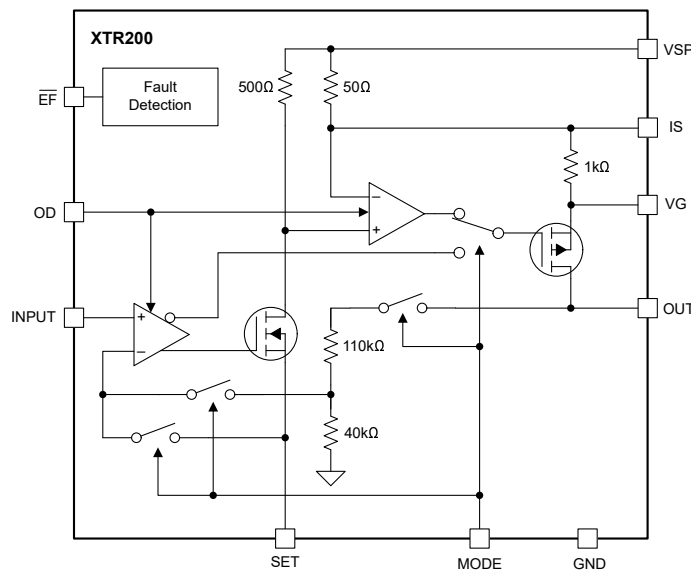

6.3 Feature Description

6.3.1 Explanation of Pin Functions

INPUT: This input is a conventional, noninverting, high-impedance input of an operational amplifier (op amp). This pin is designed for voltages from 0V to 5V. The internal circuitry is protected by clamp diodes to ground and an internal 5V reference. Applying voltages beyond 0V to 5V causes a large amount of current to flow through the clamp diodes and potentially damage the device. An external series resistor can be used to limit current through the clamp diodes if voltages beyond the 0V to 5V range are expected.

MODE: This input determines the output mode of the XTR200. Applying a voltage greater than 2V selects current-output mode. A voltage less than 0.8V above ground selects voltage-output mode. This pin has a weak internal pullup to 3.3V.

EF : The active-low error flag (logic output) indicates the fault conditions listed in [Error Flag](#). This pin has a weak internal pullup resistor to 3.3V. The pin can be used with a pullup resistor to an external voltage source for different voltage levels. Leave the pin unconnected if not used.

OD: This control input has a 4 μ A internal pullup current source disabling the output. Pulling the pin low, within 0.8V of GND, is required to activate the output. Control OD to reduce output glitches during power on and power off. If not used, connect this pin to ground to enable the output continuously.

SET: The total resistance connected between this pin and the ground reference sets the voltage-to-current transfer ratio. Additional series resistance introduced by improper PCB layout degrades precision. The voltage on this pin must not exceed 5V.

IS: This output pin is connected to the source or emitter of an external transistor (PMOS or PNP) if one is used. If no external transistor is used, short this pin to the VG pin for proper functionality.

VG: This output pin drives the gate or base of an external transistor. Short this pin to the IS pin if no external transistor is used.

VSP: This is the positive power supply for the internal circuitry of the XTR200. The XTR200 tolerates supply voltages up to a maximum of 65V, which allows the XTR200 to operate in harsh industrial environments. Use a bypass capacitor (>100nF) and optionally a damping inductor or a small resistor (5 Ω) to decouple the XTR200 supply from the noise typically found on industrial 24V supplies.

GND: The GND pin is both the negative power supply and the reference voltage point for the internal circuitry of the XTR200. The input voltage, logic levels, and R_{SET} voltage are measured with respect to this point. Provide a low-impedance connection to the system ground for reliable operation.

OUT: This pin delivers load current from the internal PMOS transistor. If using an external transistor, connect the OUT pin to the collector or drain of the external PNP or PMOS transistor.

6.3.2 Using an External Transistor

The XTR200 integrates an output transistor capable of delivering the specified output current to a wide range of load resistances. However, in applications with high supply voltages, using an external transistor reduces the power dissipated in the XTR200. The [Power Supply Recommendations](#) section provides useful information on supply voltage and PCB temperature limitations when using the internal output transistor. Establish that the external transistor is rated for the maximum anticipated supply voltage and is capable of dissipating the power generated by the load current and the voltage drop across the transistor.

[Figure 6-1](#) and [Figure 6-2](#) display the current flow when using an external PNP or PMOS transistor with the XTR200. A portion of the load current flows through the internal 1k Ω resistor between the IS and VG pins, producing a voltage which turns on the external transistor. The voltage between the IS and VG pins is limited to approximately 2V by a clamp circuit represented by a Zener diode in the diagram. A small portion of the output load current still flows through the internal PMOS of the XTR200 but is recombined with the current through the external transistor. When using an external PNP transistor, the base current is recirculated through the internal PMOS (Q2) and does not degrade the accuracy of the output current.

All load current flows through the on-chip 50Ω resistor in the XTR200 which is used to measure output current and detect fault conditions. For this reason, using an external transistor does not change the transfer function of the XTR200 or increase the maximum output current. External transistors are protected from short-circuit faults by the same circuitry which protects the internal output PMOS.

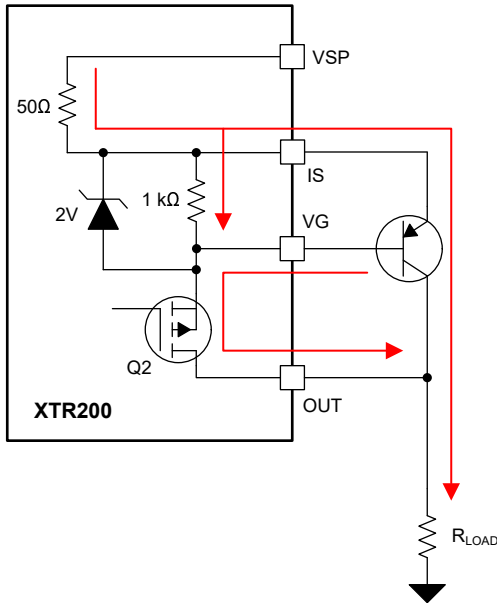

Figure 6-1. Current Pathways for an External PNP Transistor

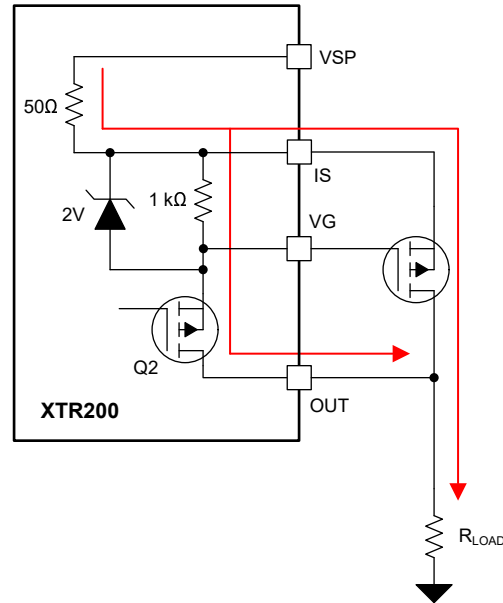

Figure 6-2. Current Pathways for an External PMOS Transistor

6.3.3 Error Flag

The XTR200 has internal circuitry that detects the error states listed in Table 6-1. When an error state is detected, the error flag \overline{EF} (an open-drain logic output), pulls low. This digital output can be pulled up to an external logic voltage through a resistor. The internal pullup current is 4μA to an internal 3.3V reference.

Table 6-1. Error States Indicated by Error Flag

Error State	Description
Output short	Short-circuit current limit reached in voltage output mode
Output open	Unable to reach correct output current in current output mode. This fault condition is only detectable with an input voltage of >350mV and a supply voltage of >10V.
Output saturation	Insufficient headroom between load voltage and supply voltage to achieve correct voltage or current output. This fault condition is only detectable with a supply voltage of >10V.
SET pin short	SET pin current exceeding 1/10th of the output short circuit current limit
Power supply under voltage	Power supply voltage under 8V
High die temperature	Die temperature exceeding 130°C

6.4 Device Functional Modes

6.4.1 Current-Output Mode

Applying a voltage greater than 2V to the MODE pin places the XTR200 into current-output mode. In current-output mode, the XTR200 acts as a voltage-controlled current source. Figure 6-3 shows the internal configuration of the XTR200, as well as the current flow inside the device. When a voltage is applied to the input, amplifier A1 drives the gate of NMOS transistor Q1, which causes a current I_{SET} to flow through the external resistor R_{SET} . The voltage at the SET pin is fed back to the inverting input of amplifier A1 through switch SW1. This feedback loop forces the voltage at the SET pin to equal the input voltage, as shown in Equation 1.

$$I_{SET} = V_{IN}/R_{SET} \quad (1)$$

I_{SET} also flows through the 500Ω resistor connected between the drain of Q1 and the power supply, VSP. Amplifier A2 senses the voltage drop across this 500Ω resistor and drives the gate of the PMOS output transistor Q2 through switch SW4. This action creates an equal voltage drop across the 50Ω resistor at the inverting input connected between the source of Q2 and VSP. To produce an equal voltage at the input terminals of amplifier A2, 10 times more current must flow through the 50Ω resistor, as shown in Equation 2

$$I_{OUT} = 10 \times I_{SET} \quad (2)$$

The general equation for the transfer function in current-output mode is:

$$I_{OUT} = 10 \times \frac{V_{IN}}{R_{SET}} \quad (3)$$

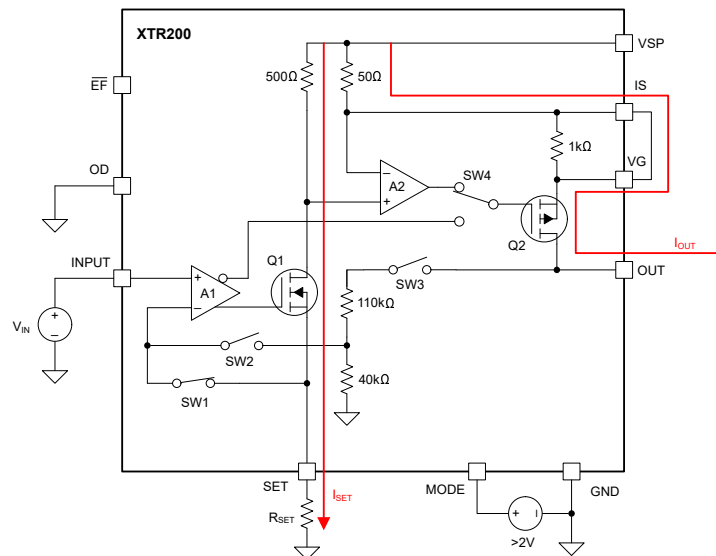

Figure 6-3. XTR200 Internal Configuration and Current Flow in Current-Output Mode

6.4.2 Voltage-Output Mode

Pulling the MODE pin low places the XTR200 into voltage-output mode. Figure 6-4 shows the internal configuration of the device in voltage-output mode. Amplifier A2 is now bypassed and the inverted output of amplifier A1 controls the output transistor Q2 through switch SW4. Switches SW2 and SW3 close the feedback loop through the on-chip voltage divider consisting of 110kΩ and 40kΩ resistors. These resistors are fabricated using a high-precision thin-film deposition and precision layout techniques to deliver extremely low gain error over the full temperature range.

6.4.4 Thermal Shutdown

The error flag pin (\overline{EF}) of the XTR200 indicates a die temperature above 130°C as a warning of a fault condition. If the die temperature continues to rise, the XTR200 enters into a thermal shutdown state when the die temperature exceeds 160°C. In the thermal shutdown state, the output is disabled (high impedance) until the die temperature cools below 125°C. If the external fault condition which initially produced the high die temperature has not been remedied, the device oscillates in and out of the thermal shutdown state until the fault is removed.

7 Application and Implementation

Note

Information in the following applications sections is not part of the TI component specification, and TI does not warrant its accuracy or completeness. TI's customers are responsible for determining suitability of components for their purposes, as well as validating and testing their design implementation to confirm system functionality.

7.1 Application Information

7.1.1 Input Voltage

The linear input voltage range extends from 0V to 5V. The input voltage is referenced to the grounding point of R_{SET} . Verify that R_{SET} is not distorted from other currents. Assuming a 3V full-scale input signal for a 20mA output current, R_{SET} is 1.5k Ω . A resistance uncertainty of just 1.5 Ω already degrades the accuracy to below 0.1%. Select a precision, low-drift resistor for best performance because resistor drift directly converts into drift of the output current. Design the layout carefully to minimize any series resistance with R_{SET} and the input reference point.

Do not drive the input negative (referred to GND) greater than 500mV. Higher negative voltages turn on the internal protection diodes. Insert a resistor in series with the input if negative signals can eventually occur during power on, power off, or other transient conditions.

Use a voltage divider to add an offset voltage to the input voltage for a 4mA to 20mA signaling range as shown in Figure 7-1. In this approach, an offset voltage is derived from a voltage reference and voltage divider, such that the XTR200 delivers 4mA to the load when the DAC output voltage is 0V, preserving DAC resolution.

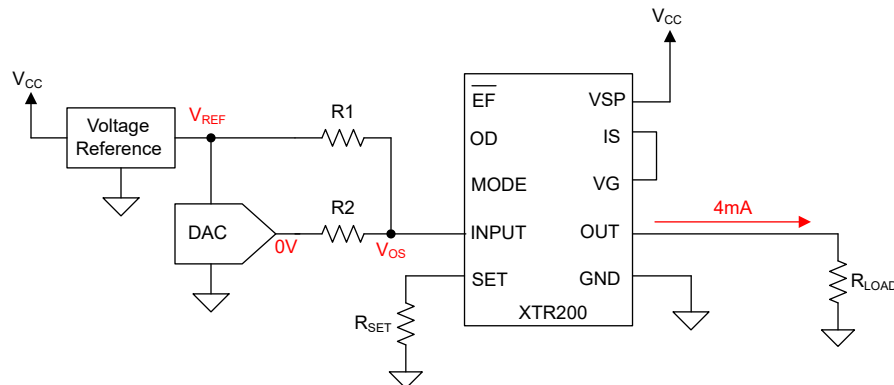

Figure 7-1. Adding an Offset Voltage to the XTR200 Input for 4mA to 20mA Signaling

Use Equation 5 to calculate the offset voltage, V_{OS} , required for a 4mA output.

$$V_{OS} = \frac{4\text{mA} \times R_{SET}}{10} \quad (5)$$

When the necessary offset voltage is calculated, calculate the values of R_1 and R_2 using the equation:

$$V_{OS} = V_{REF} \times \frac{R_2}{R_1 + R_2} \quad (6)$$

Consider the minimum output voltage of the DAC when designing this circuit. Some DACs do not reach all the way to 0V.

7.1.2 Miswiring Protection

On occasion, miswiring faults occur when field transmitters are installed in industrial environments. If the OUT pin of the XTR200 is mistakenly connected to the power supply, and the VSP pin is grounded, the on-chip ESD diode between these pins is forward biased. The forward bias causes a large current to flow and damage the IC. [Figure 7-2](#) shows the addition of a miswiring protection diode in series with the XTR200 power supply. This diode prevents reverse current from flowing out of the VSP pin through the ESD diode. The supply bypass capacitor, C_{BYP} , placed at the VSP pin provides a low-impedance pathway to ground for high-frequency ESD events that forward bias the on-chip ESD diode. Include the forward voltage drop of the miswiring protection diode when calculating the minimum supply voltage to provide the necessary headroom for the XTR200.

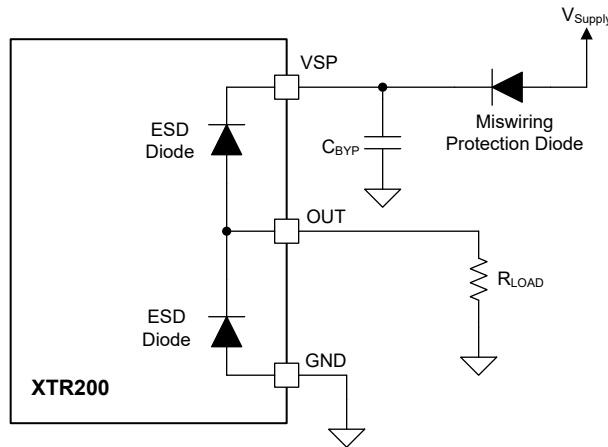

Figure 7-2. Miswiring Protection Diode in Series with Supply

A diode in series with the power supply of the XTR200 does not protect against a miswiring fault where the GND pin is connected to a supply voltage and the OUT pin is connected to ground.

7.1.3 Power Dissipation in Current Output Mode

In current-output mode, the combination of low load resistances and relatively high output currents causes increased power dissipation in the XTR200 when using the internal output transistor. [Equation 7](#) calculate the power dissipated in the XTR200.

$$P_D = V_{SP}I_Q + \left(V_{SP} - \frac{I_O R_{SET}}{10} \right) \frac{I_O}{10} + (V_{SP} - I_O R_L) I_O \quad (7)$$

Where:

- V_{SP} : Supply voltage in volts
- I_Q : Quiescent power supply current in amps (typically 325 μ A)
- I_O : Output current in amps
- R_{SET} : SET resistor value in ohms
- R_L : Load resistor value in ohms

[Equation 7](#) has three terms. The first term represents the operating dissipation of the XTR200 internal circuitry and is a function of the power supply voltage and the quiescent power supply current. The second term represents the power dissipated in the SET pathway of the XTR200 and is a function of the supply voltage, the SET current (1/10th the output current) and the SET resistor, R_{SET} .

The last, and most significant, term of the equation represents the power dissipation in the output circuitry of the XTR200 and is a function of the supply voltage, output current, and load resistance. Use the calculated power dissipation with the method [Estimating Junction Temperature](#) shows to estimate the XTR200 junction temperature for a given use case.

Figure 7-3 shows the power dissipation of an XTR200 in current output mode using the internal transistor, a 24V supply, and a 1.33kΩ R_{SET} for various load resistances. Power dissipation in the XTR200 is highest for low resistance loads and high output currents. Power dissipation decreases once the load voltage exceeds the voltage drop across the output circuitry of the XTR200 as seen in the 500Ω load case above 26mA of output current.

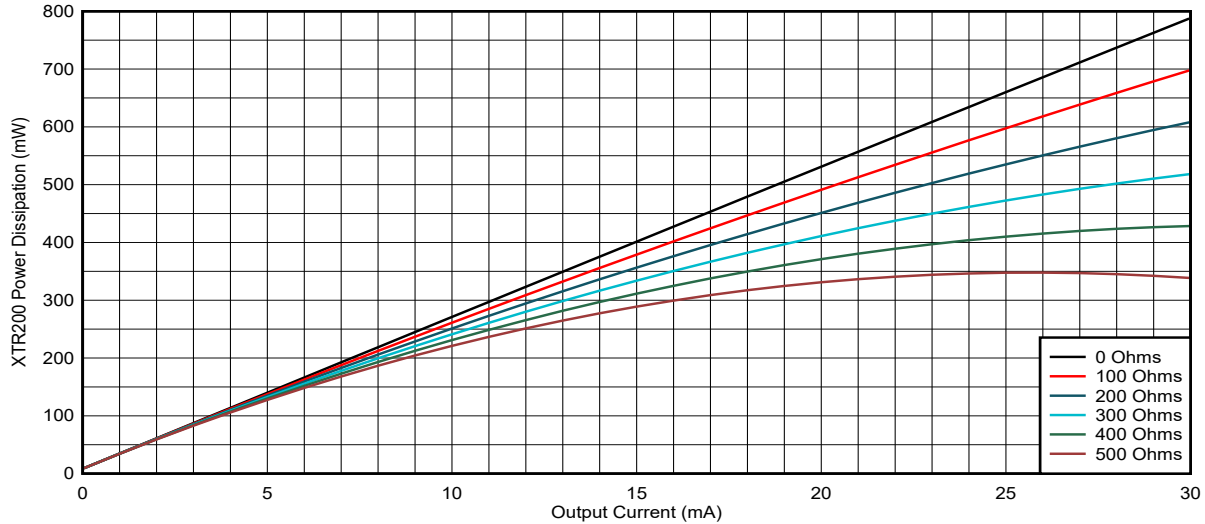

Figure 7-3. XTR200 Power Dissipation vs Output Current and Load Resistance (V_{SP} = 24V, R_{SET} = 1.33kΩ)

7.1.4 Estimating Junction Temperature

The JEDEC standard now recommends using psi (Ψ) thermal metrics to estimate the junction temperatures of the LDO when in-circuit on a typical PCB board application. These metrics are not thermal resistance parameters and instead offer a practical and relative way to estimate junction temperature. These psi metrics are determined as significantly independent of the copper area available for heat-spreading.

The [Thermal Information](#) table lists the primary thermal metrics, which are the junction-to-top characterization parameter (Ψ_{JT}) and junction-to-board characterization parameter (Ψ_{JB}). These parameters provide two methods for calculating the junction temperature (T_J), as described in the following equations. Use the junction-to-top characterization parameter (Ψ_{JT}) with the temperature at the center-top of device package (T_T) to calculate the junction temperature. Use the junction-to-board characterization parameter (Ψ_{JB}) with the PCB surface temperature 1mm from the device package (T_B) to calculate the junction temperature.

$$T_J = T_T + \Psi_{JT} \times P_D \quad (8)$$

where

- P_D is the dissipated power
- T_T is the temperature at the center-top of the device package

$$T_J = T_B + \Psi_{JB} \times P_D \quad (9)$$

where

- T_B is the PCB surface temperature measured 1mm from the device package and centered on the package edge

For detailed information on the thermal metrics and how to use them, see the [Semiconductor and IC Package Thermal Metrics](#) application note.

7.2 Typical Applications

7.2.1 Analog Output Circuitry for Field Transmitters

The XTR200 is designed as a fully-integrated output driver for field transmitters that transmit analog information in standard industrial ranges of 0mA to 20mA, 4mA to 20mA, and 0V to 10V. Figure 7-4 shows a simplified schematic of the output circuitry of field transmitter. A digital-to-analog converter (DAC) provides the input signal to the XTR200 while a microcontroller controls the MODE and Output Disable (OD) pins and monitors the error flag pin. The XTR200 can run directly from the loop supply, which is specified for a range of 18V to 36V. The device is configured to use the internal output transistor to drive the load by shorting the IS and VG pins together.

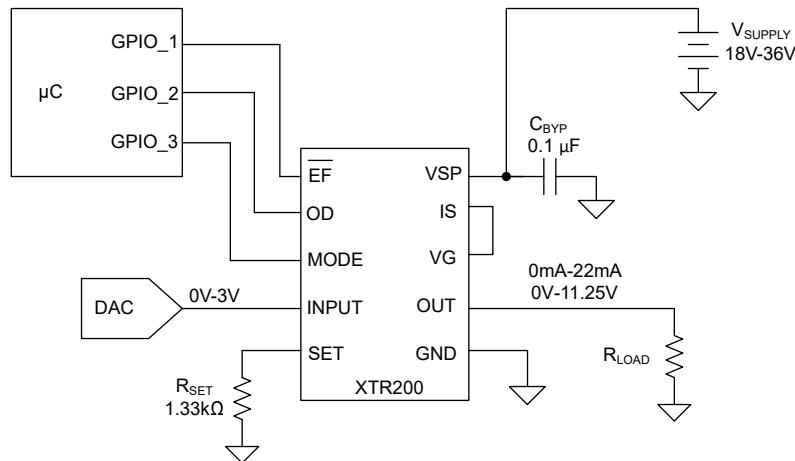

Figure 7-4. XTR200 Configured to Provide Standard Industrial Current and Voltage Outputs

7.2.1.1 Design Requirements

The design requirements for this application are listed in Table 7-1. These are chosen to closely represent the design requirements of industrial field transmitters.

Although the standard ranges for transmitting information are 0mA to 20mA, 4mA to 20mA, and 0V to 10V, currents above 20mA and voltages above 10V are often used to indicate error conditions. This is why the design requirements specify output currents up to 22mA and output voltages up to 11.25V.

Table 7-1. Design Parameters

Parameter	Value
Input voltage range	0V to 3V
Power supply voltage	18V to 36V
Output current range	0mA to 22mA
Output voltage range	0V to 11.25V
Operating temperature range	-40°C to 85°C
Load Resistance (Current Output)	0Ω to 500Ω
Load Resistance (Voltage Output)	>1000Ω

7.2.1.2 Detailed Design Procedure

The only calculation required to complete the circuit design is a single external component, R_{SET} . Resistor R_{SET} determines the voltage-to-current transfer function of the circuit. The value of R_{SET} is calculated using the maximum input voltage and the maximum output current as shown in Equation 10.

$$R_{SET} = 10 \times \frac{V_{IN(MAX)}}{I_{OUT(MAX)}} = 10 \times \frac{3V}{22mA} = 1363.64\Omega \rightarrow 1.33k\Omega \quad (10)$$

A value of 1.33k Ω is chosen for R_{SET} as this is a standard 1% resistor value that is very close to the calculated value of 1363.64 Ω and can still provide the required maximum output current of 22mA. Select a resistor with a low temperature coefficient and tight value tolerance to minimize the error introduced by this external component.

No calculations are required to set the output voltage transfer function. The XTR200 has a fixed gain of 3.75V/V in voltage-output mode which is sufficient for a variety of DAC output voltage ranges.

Consider the headroom requirement of the XTR200 when evaluating the load resistance and power supply voltage ranges. The worst case scenario is a minimum supply voltage of 18V and the maximum output current (22mA) into the maximum load resistor (500 Ω). In this case, the load voltage is 11V and the headroom (the difference between supply voltage and load voltage) is 7V. This case is well above the 2.5V headroom requirement of the XTR200 and sufficient for proper operation. The required maximum power supply voltage, 36V, is well within the limits recommended in [Power Supply Recommendations](#) when using the internal transistor.

Figure 7-4 also shows a 0.1 μ F bypass capacitor, C_{BYP} , on the power supply pin, VSP, of the XTR200. The bypass capacitor location is a good design practice and helps provide a low-impedance supply for the XTR200 and filter out any residual noise on the power supply.

7.2.1.3 Application Curves

Figure 7-5 and Figure 7-6 show the output current and voltage transfer functions of the circuit. The calculated value of R_{SET} , 1.33k Ω , gives a maximum output current of 22.56mA for an input voltage of 3V. The maximum output voltage is 11.25V for an input voltage of 3V.

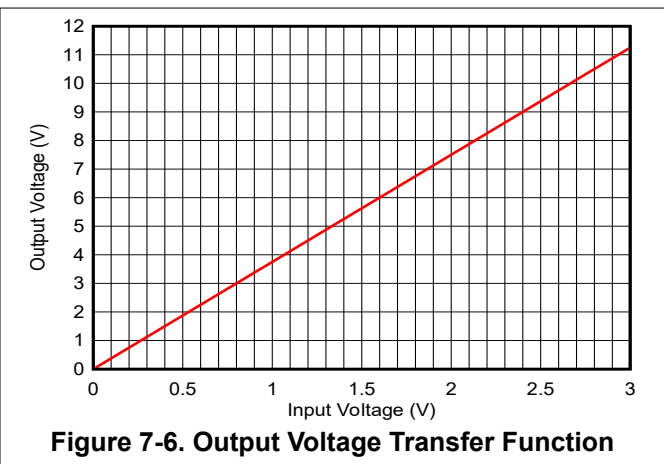
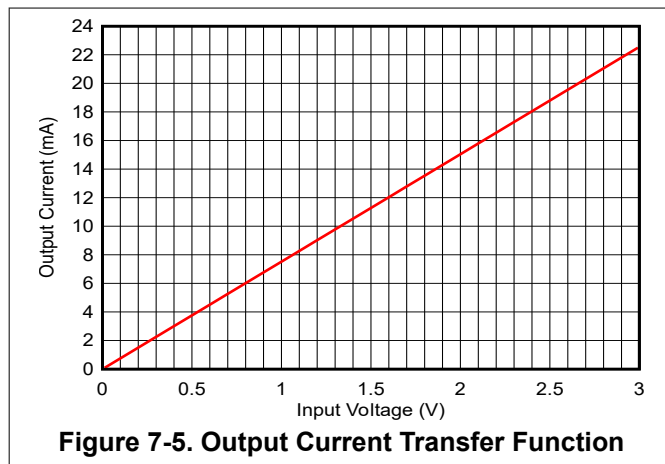

7.3 Power Supply Recommendations

The XTR200 operates over a supply voltage range of 8V to 60V. However, consider the environmental temperature, load current, and load resistance in the overall system design. Figure 7-7 shows the thermally-limited maximum supply voltage of the XTR200 over a range of PCB temperatures. Figure 7-7 shows a worst-case scenario of 22mA output current into a 0Ω load using the internal output transistor, IS and VG pins shorted.

The black curve shows the supply voltage resulting in a 125°C junction temperature (the maximum specified temperature of the XTR200) for the given PCB temperature. At approximately 130°C, the Error Flag pin (EF) voltage goes low, warning of high junction temperature. The red curve shows the supply voltages resulting in a 150°C junction temperature (maximum operating temperature of the XTR200) for a given PCB temperature.

The XTR200 thermal shutdown circuitry disables the output for junction temperatures above 150°C. When the junction temperature falls back below 125°C, the output is re-enabled. For PCB temperatures below 70°C, the maximum recommended supply voltage is limited by the voltage rating of the XTR200 internal circuitry rather than thermal considerations. If high-temperature and high-supply-voltage operation is required, use an external transistor to deliver the load current as described in [Using an External Transistor](#).

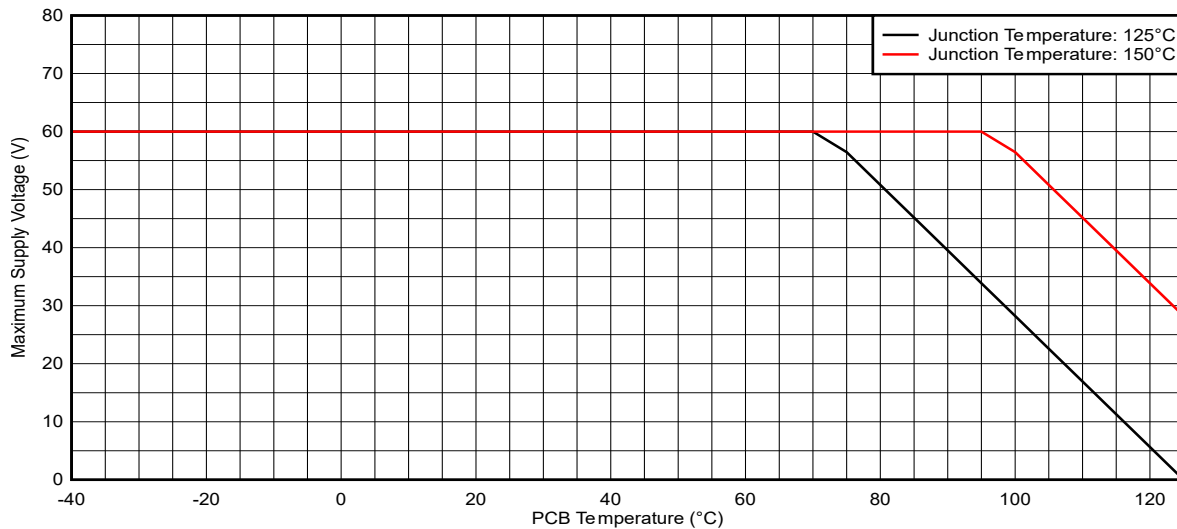

Figure 7-7. Maximum Recommended Supply Voltage vs PCB Temperature (Internal Output Transistor)

Consider the headroom specification of the XTR200 when determining the working power supply range of a system. The term headroom defines the difference between the supply voltage of the XTR200 and the load voltage as shown in Figure 7-8. Above the minimum supply voltage, 8V, confirm that the XTR200 supply voltage is at least 2.5V above the load voltage.

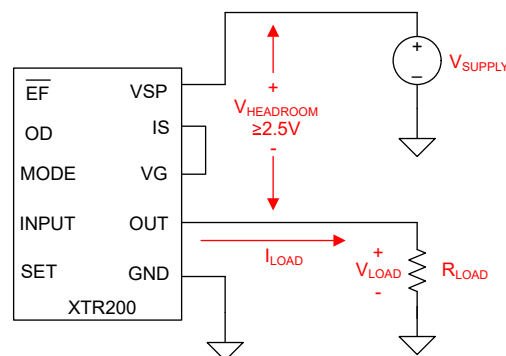

Figure 7-8. XTR200 Headroom

7.4 Layout

7.4.1 Layout Guidelines

Figure 7-9 shows an example layout for the XTR200. For particular requirements of an application or PCB assembly process, refine the layout. To maximize the performance of the device:

- Place the R_{SET} resistor as close as possible to the SET and GND pins to minimize trace resistance in series with the R_{SET} resistor.
- When using the integrated output transistor, short the IS and VG pins together as close as possible to the device. This reduces trace resistance to maximize output headroom and prevent noise coupling into the output signal.
- Place power supply bypass capacitors near the power supply pin, between the device and any vias used for the supply connection. Provide a low impedance connection to ground for bypass capacitors.
- Connect the thermal pad to a ground plane or pour and, if possible, extend the ground pour beyond the device to maximize power dissipation.

Soldering the exposed pad significantly improves board-level reliability during temperature cycling, key push, package shear, and similar board-level tests. Even with applications that have low power dissipation, solder the exposed pad to the PCB to provide structural integrity and long-term reliability. Physical dimensions for the package and pad are shown in [Mechanical, Packaging, and Orderable Information](#).

7.4.2 Layout Example

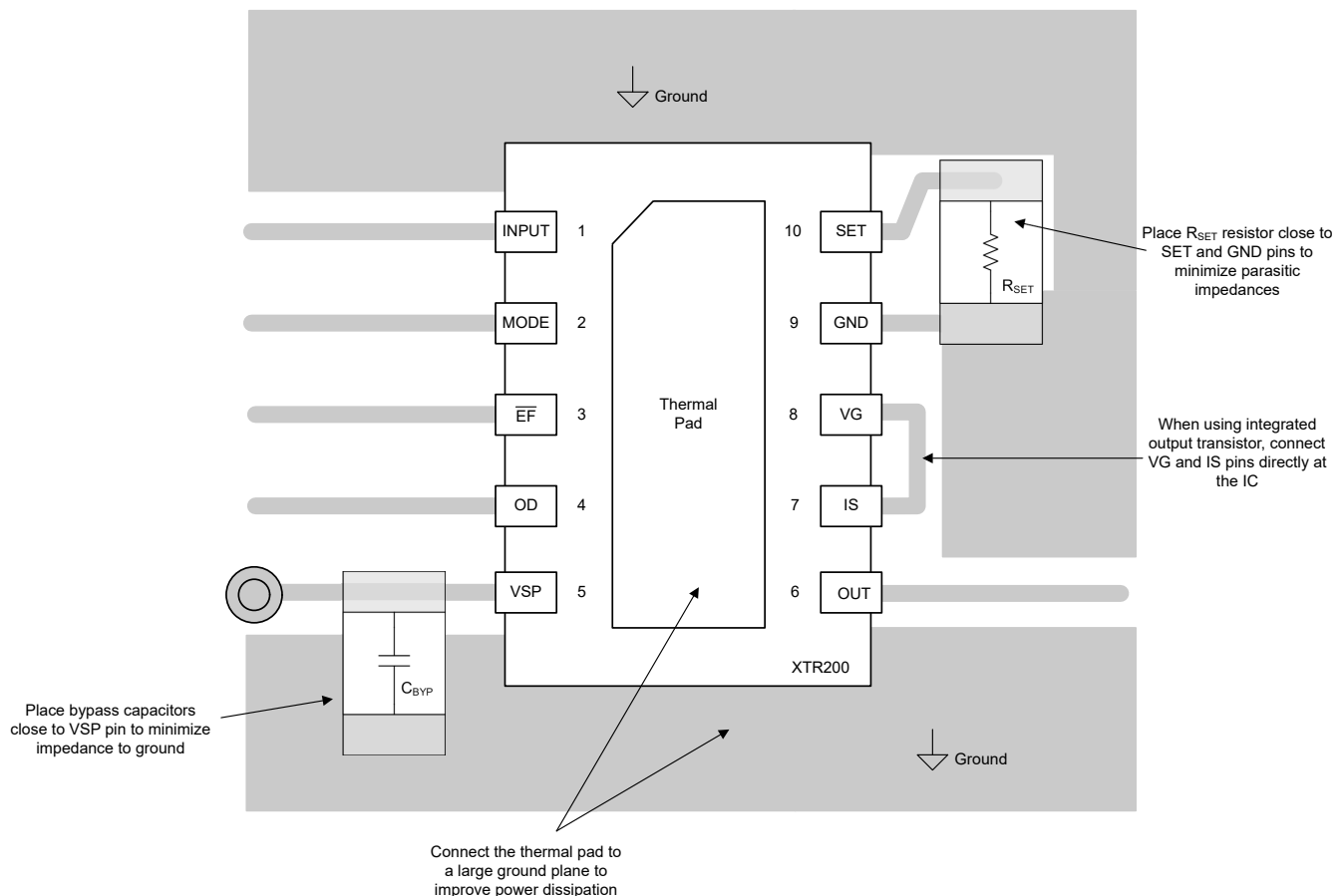

Figure 7-9. Layout Example

8 Device and Documentation Support

TI offers an extensive line of development tools. Tools and software to evaluate the performance of the device, generate code, and develop solutions are listed below.

8.1 Device Support

8.1.1 Third-Party Products Disclaimer

TI'S PUBLICATION OF INFORMATION REGARDING THIRD-PARTY PRODUCTS OR SERVICES DOES NOT CONSTITUTE AN ENDORSEMENT REGARDING THE SUITABILITY OF SUCH PRODUCTS OR SERVICES OR A WARRANTY, REPRESENTATION OR ENDORSEMENT OF SUCH PRODUCTS OR SERVICES, EITHER ALONE OR IN COMBINATION WITH ANY TI PRODUCT OR SERVICE.

8.2 Documentation Support

8.2.1 Related Documentation

For related documentation see the following:

- Texas Instruments, [XTR200 Evaluation Module User's Guide](#)
- Texas Instruments, [How to Select Amplifiers for Pressure Transmitter Applications application brief](#)
- Texas Instruments, [Special Function Amplifiers Precision Labs video series](#) on Current Loop Transmitters

8.3 Receiving Notification of Documentation Updates

To receive notification of documentation updates, navigate to the device product folder on [ti.com](#). Click on *Notifications* to register and receive a weekly digest of any product information that has changed. For change details, review the revision history included in any revised document.

8.4 Support Resources

TI E2E™ [support forums](#) are an engineer's go-to source for fast, verified answers and design help — straight from the experts. Search existing answers or ask your own question to get the quick design help you need.

Linked content is provided "AS IS" by the respective contributors. They do not constitute TI specifications and do not necessarily reflect TI's views; see TI's [Terms of Use](#).

8.5 Trademarks

TI E2E™ is a trademark of Texas Instruments.
All trademarks are the property of their respective owners.

8.6 Electrostatic Discharge Caution



This integrated circuit can be damaged by ESD. Texas Instruments recommends that all integrated circuits be handled with appropriate precautions. Failure to observe proper handling and installation procedures can cause damage.

ESD damage can range from subtle performance degradation to complete device failure. Precision integrated circuits may be more susceptible to damage because very small parametric changes could cause the device not to meet its published specifications.

8.7 Glossary

[TI Glossary](#) This glossary lists and explains terms, acronyms, and definitions.

9 Revision History

NOTE: Page numbers for previous revisions may differ from page numbers in the current version.

DATE	REVISION	NOTES
June 2025	*	Initial Release

10 Mechanical, Packaging, and Orderable Information

The following pages include mechanical, packaging, and orderable information. This information is the most current data available for the designated devices. This data is subject to change without notice and revision of this document. For browser-based versions of this data sheet, refer to the left-hand navigation.



DQC0010A

PACKAGE OUTLINE
WSO - 0.8mm max height

PLASTIC SMALL OUTLINE - NO LEAD

ADVANCE INFORMATION

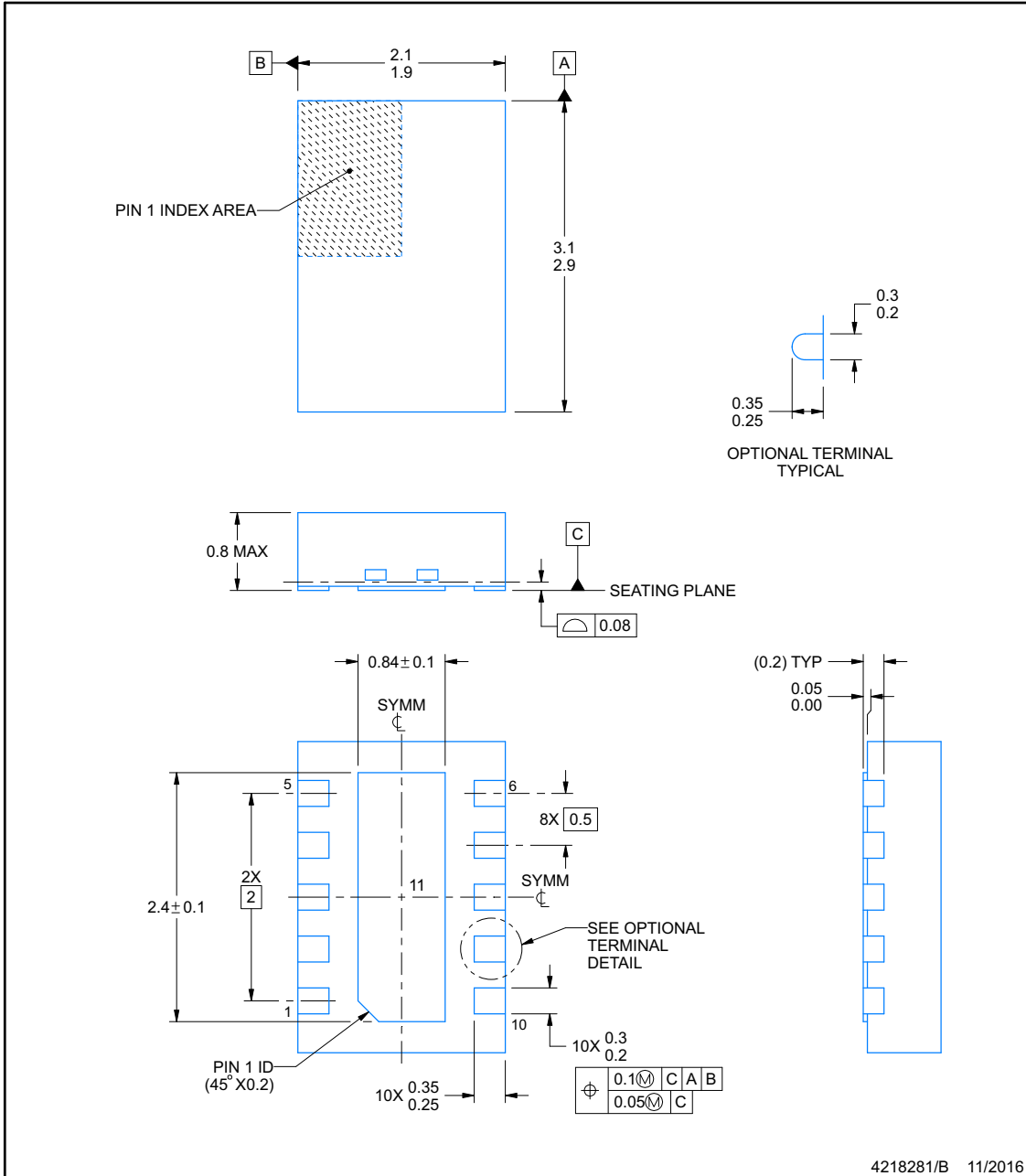

4218281/B 11/2016

NOTES:

1. All linear dimensions are in millimeters. Any dimensions in parenthesis are for reference only. Dimensioning and tolerancing per ASME Y14.5M.
2. This drawing is subject to change without notice.
3. The package thermal pad must be soldered to the printed circuit board for thermal and mechanical performance.

EXAMPLE BOARD LAYOUT

DQC0010A

WSON - 0.8mm max height

PLASTIC SMALL OUTLINE - NO LEAD

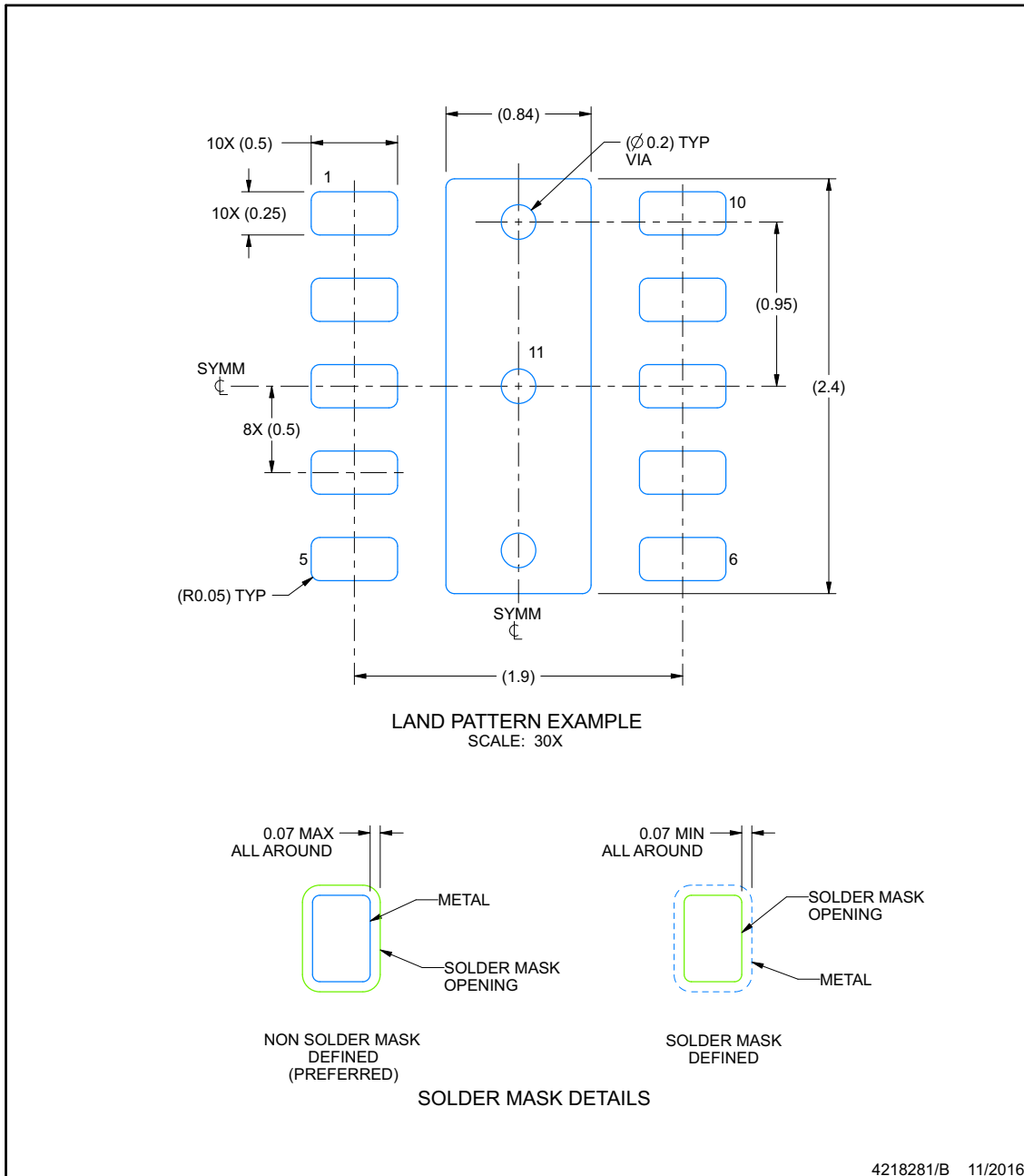

NOTES: (continued)

- This package is designed to be soldered to a thermal pad on the board. For more information, see Texas Instruments literature number SLUA271 (www.ti.com/lit/sluea271).
- Vias are optional depending on application, refer to device data sheet. If any vias are implemented, refer to their locations shown on this view. It is recommended that vias under paste be filled, plugged or tented.

EXAMPLE STENCIL DESIGN

DQC0010A

WSO - 0.8mm max height

PLASTIC SMALL OUTLINE - NO LEAD

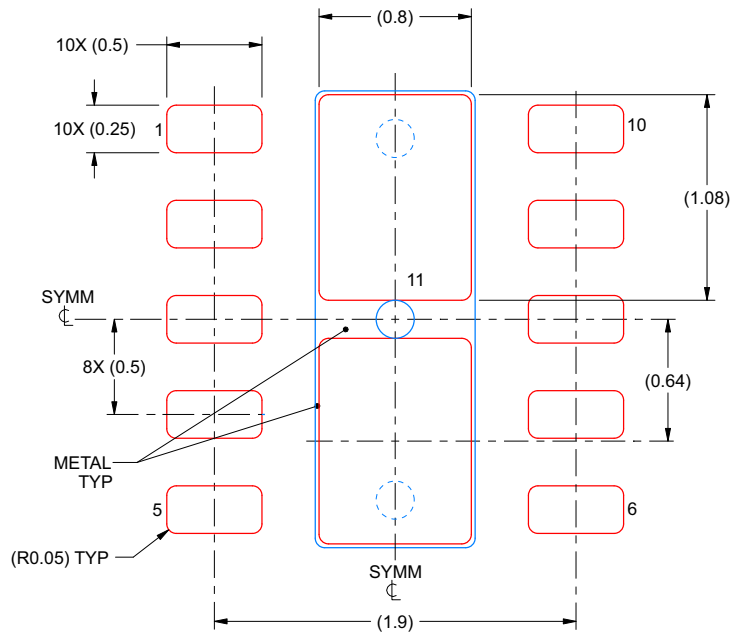

SOLDER PASTE EXAMPLE
BASED ON 0.125 mm THICK STENCIL

EXPOSED PAD 11:
86% PRINTED SOLDER COVERAGE BY AREA UNDER PACKAGE
SCALE: 30X

4218281/B 11/2016

NOTES: (continued)

6. Laser cutting apertures with trapezoidal walls and rounded corners may offer better paste release. IPC-7525 may have alternate design recommendations.

ADVANCE INFORMATION

PACKAGING INFORMATION

Orderable part number	Status (1)	Material type (2)	Package Pins	Package qty Carrier	RoHS (3)	Lead finish/ Ball material (4)	MSL rating/ Peak reflow (5)	Op temp (°C)	Part marking (6)
PXTR200DQCR	Active	Preproduction	WSON (DQC) 10	3000 LARGE T&R	-	Call TI	Call TI	-40 to 125	

(1) **Status:** For more details on status, see our [product life cycle](#).

(2) **Material type:** When designated, preproduction parts are prototypes/experimental devices, and are not yet approved or released for full production. Testing and final process, including without limitation quality assurance, reliability performance testing, and/or process qualification, may not yet be complete, and this item is subject to further changes or possible discontinuation. If available for ordering, purchases will be subject to an additional waiver at checkout, and are intended for early internal evaluation purposes only. These items are sold without warranties of any kind.

(3) **RoHS values:** Yes, No, RoHS Exempt. See the [TI RoHS Statement](#) for additional information and value definition.

(4) **Lead finish/Ball material:** Parts may have multiple material finish options. Finish options are separated by a vertical ruled line. Lead finish/Ball material values may wrap to two lines if the finish value exceeds the maximum column width.

(5) **MSL rating/Peak reflow:** The moisture sensitivity level ratings and peak solder (reflow) temperatures. In the event that a part has multiple moisture sensitivity ratings, only the lowest level per JEDEC standards is shown. Refer to the shipping label for the actual reflow temperature that will be used to mount the part to the printed circuit board.

(6) **Part marking:** There may be an additional marking, which relates to the logo, the lot trace code information, or the environmental category of the part.

Multiple part markings will be inside parentheses. Only one part marking contained in parentheses and separated by a "-" will appear on a part. If a line is indented then it is a continuation of the previous line and the two combined represent the entire part marking for that device.

Important Information and Disclaimer: The information provided on this page represents TI's knowledge and belief as of the date that it is provided. TI bases its knowledge and belief on information provided by third parties, and makes no representation or warranty as to the accuracy of such information. Efforts are underway to better integrate information from third parties. TI has taken and continues to take reasonable steps to provide representative and accurate information but may not have conducted destructive testing or chemical analysis on incoming materials and chemicals. TI and TI suppliers consider certain information to be proprietary, and thus CAS numbers and other limited information may not be available for release.

In no event shall TI's liability arising out of such information exceed the total purchase price of the TI part(s) at issue in this document sold by TI to Customer on an annual basis.

GENERIC PACKAGE VIEW

DQC 10

WSON - 0.8 mm max height

PLASTIC SMALL OUTLINE - NO LEAD

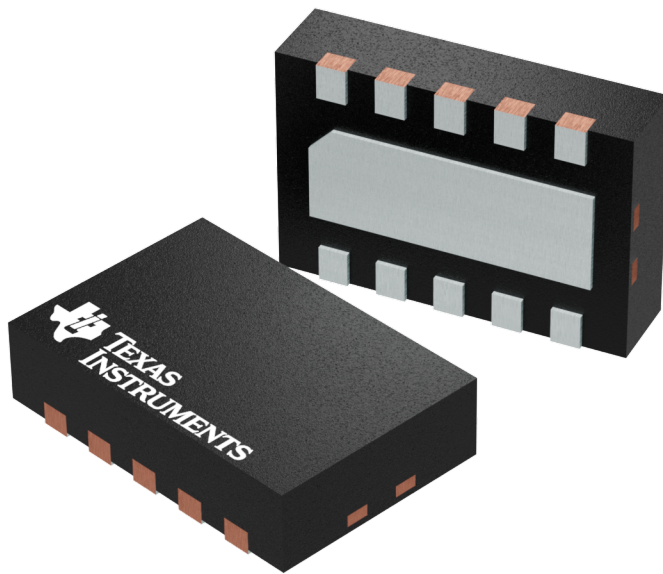

Images above are just a representation of the package family, actual package may vary.
Refer to the product data sheet for package details.

4209674/B

IMPORTANT NOTICE AND DISCLAIMER

TI PROVIDES TECHNICAL AND RELIABILITY DATA (INCLUDING DATA SHEETS), DESIGN RESOURCES (INCLUDING REFERENCE DESIGNS), APPLICATION OR OTHER DESIGN ADVICE, WEB TOOLS, SAFETY INFORMATION, AND OTHER RESOURCES "AS IS" AND WITH ALL FAULTS, AND DISCLAIMS ALL WARRANTIES, EXPRESS AND IMPLIED, INCLUDING WITHOUT LIMITATION ANY IMPLIED WARRANTIES OF MERCHANTABILITY, FITNESS FOR A PARTICULAR PURPOSE OR NON-INFRINGEMENT OF THIRD PARTY INTELLECTUAL PROPERTY RIGHTS.

These resources are intended for skilled developers designing with TI products. You are solely responsible for (1) selecting the appropriate TI products for your application, (2) designing, validating and testing your application, and (3) ensuring your application meets applicable standards, and any other safety, security, regulatory or other requirements.

These resources are subject to change without notice. TI grants you permission to use these resources only for development of an application that uses the TI products described in the resource. Other reproduction and display of these resources is prohibited. No license is granted to any other TI intellectual property right or to any third party intellectual property right. TI disclaims responsibility for, and you will fully indemnify TI and its representatives against, any claims, damages, costs, losses, and liabilities arising out of your use of these resources.

TI's products are provided subject to [TI's Terms of Sale](#) or other applicable terms available either on [ti.com](https://www.ti.com) or provided in conjunction with such TI products. TI's provision of these resources does not expand or otherwise alter TI's applicable warranties or warranty disclaimers for TI products.

TI objects to and rejects any additional or different terms you may have proposed.

Mailing Address: Texas Instruments, Post Office Box 655303, Dallas, Texas 75265

Copyright © 2025, Texas Instruments Incorporated