

## SNx4AHC123A Dual Retriggerable Monostable Multivibrators

### 1 Features

- Operating range 2V to 5.5V  $V_{CC}$
- Schmitt-trigger circuitry on  $\bar{A}$ , B, and  $\bar{CLR}$  inputs for slow input transition rates
- Edge triggered from active-high or active-low gated logic inputs
- Retriggerable for very long output pulses
- Overriding clear terminates output pulse
- Glitch-free power-up reset on outputs
- Latch-up performance exceeds 100mA per JESD 78, class II

### 2 Description

The 'AHC123A devices are dual retriggerable monostable multivibrators designed for 2V to 5.5V  $V_{CC}$  operation.

#### Device Information

PART NUMBER	PACKAGE <sup>(1)</sup>	PACKAGE SIZE <sup>(2)</sup>	BODY SIZE (NOM) <sup>(3)</sup>
SNx4AHC123A	DB (SSOP, 16)	6.50mm x 7.8mm	6.50mm x 5.30mm
	PW (TSSOP, 16)	5.00mm x 6.4mm	5.00mm x 4.40mm
	DGV (TVSOP, 16)	3.60mm x 6.4mm	3.60mm x 4.40mm
	N (PDIP, 16)	19.3mm x 9.4mm	19.3mm x 6.35mm
	D (SOIC, 16)	9.00mm x 6mm	9.00mm x 3.90mm

- (1) For more information, see [Mechanical, Packaging, and Orderable Information](#).
- (2) The package size (length × width) is a nominal value and includes pins, where applicable.
- (3) The body size (length × width) is a nominal value and does not include pins.

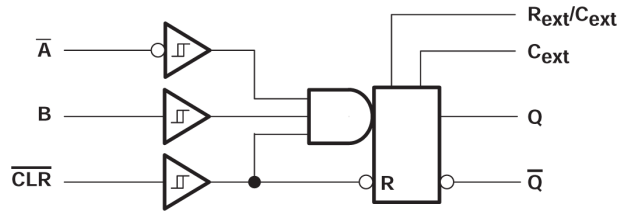

Logic Diagram, Each Multivibrator (Positive Logic)



## Table of Contents

<b>1 Features</b> .....	1	6.1 Overview.....	10
<b>2 Description</b> .....	1	6.2 Functional Block Diagram.....	10
<b>3 Pin Configuration and Functions</b> .....	3	6.3 Device Functional Modes.....	10
<b>4 Specifications</b> .....	4	<b>7 Application and Implementation</b> .....	11
4.1 Absolute Maximum Ratings.....	4	7.1 Application Information .....	11
4.2 ESD Ratings.....	4	7.2 Power Supply Recommendations.....	14
4.3 Recommended Operating Conditions.....	4	7.3 Layout.....	14
4.4 Thermal Information.....	5	<b>8 Device and Documentation Support</b> .....	17
4.5 Electrical Characteristics.....	5	8.1 Documentation Support.....	17
4.6 Timing Requirements, $V_{CC} = 3.3V \pm 0.3V$ .....	5	8.2 Receiving Notification of Documentation Updates....	17
4.7 Timing Requirements, $V_{CC} = 5V \pm 0.5V$ .....	6	8.3 Support Resources.....	17
4.8 Switching Characteristics, $V_{CC} = 3.3V \pm 0.3V$ .....	6	8.4 Trademarks.....	17
4.9 Switching Characteristics, $V_{CC} = 5V \pm 0.5V$ .....	7	8.5 Electrostatic Discharge Caution.....	17
4.10 Operating Characteristics.....	7	8.6 Glossary.....	17
4.11 Input/Output Timing Diagram.....	8	<b>9 Revision History</b> .....	17
<b>5 Parameter Measurement Information</b> .....	9	<b>10 Mechanical, Packaging, and Orderable Information</b> .....	17
<b>6 Detailed Description</b> .....	10		

### 3 Pin Configuration and Functions

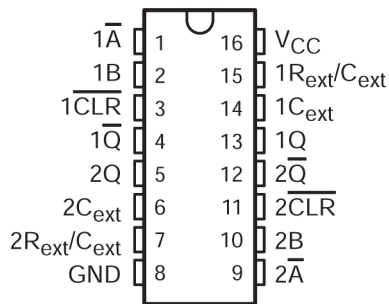

**Figure 3-1. SN54AHC123A J or W Package;  
SN74AHC123A D, DB, DGV, N, or PW Package; 16-  
Pin CDIP, CFP, SOIC, SSOP, TVSOP, PDIP, TSSOP  
(Top View)**

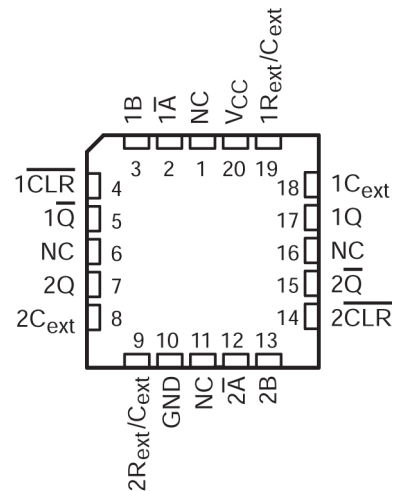

NC – No internal connection

**Figure 3-2. SN54AHC123A FK Package, 20-Pin  
LCCC (Top View)**

**Table 3-1. Pin Functions**

PIN		I/O1	DESCRIPTION
NAME	NO.		
1 $\bar{A}$	1	I	Channel 1 falling edge trigger input when 1B = H; Hold low for other input methods
1B	2	I	Channel 1 rising edge trigger input when 1 $\bar{A}$ = L; Hold high for other input methods
1 $\overline{\text{CLR}}$	3	I	Channel 1 rising edge trigger when 1 $\bar{A}$ = L and 1B = H; Hold high for other input methods; Can cut pulse length short by driving low during output
1 $\bar{Q}$	4	O	Channel 1 inverted output
2Q	5	O	Channel 2 output
2C <sub>ext</sub>	6	—	Channel 2 external capacitor negative connection
2R <sub>ext</sub> /C <sub>ext</sub>	7	—	Channel 2 external capacitor and resistor junction connection
GND	8	—	Ground
2 $\bar{A}$	9	I	Channel 2 falling edge trigger input when 2B = H; Hold low for other input methods
2B	10	I	Channel 2 rising edge trigger input when 2 $\bar{A}$ = L; Hold high for other input methods
2 $\overline{\text{CLR}}$	11	I	Channel 2 rising edge trigger when 2 $\bar{A}$ = L and 2B = H; Hold high for other input methods; Can cut pulse length short by driving low during output
2 $\bar{Q}$	12	O	Channel 2 inverted output
1Q	13	O	Channel 1 output
1C <sub>ext</sub>	14	—	Channel 1 external capacitor negative connection
1R <sub>ext</sub> /C <sub>ext</sub>	15	—	Channel 1 external capacitor and resistor junction connection
V <sub>CC</sub>	16	—	Power supply

1. I = Input, O = Output, I/O = Input or Output, G = Ground, P = Power

## 4 Specifications

### 4.1 Absolute Maximum Ratings

over operating free-air temperature (unless otherwise noted)<sup>(1)</sup>

		MIN	MAX	UNIT
$V_{CC}$ <sup>(2)</sup>	Supply voltage range	-0.5	7	V
$V_I$ <sup>(3)</sup>	Input voltage range	-0.5	7	V
$V_O$ <sup>(2)</sup>	Output voltage range in high or low state	-0.5	$V_{CC} + 0.5$	V
$V_O$ <sup>(2)</sup>	Output voltage range in power-off state	-0.5	7	V
$I_{IK}$	Input clamp current	$(V_I < 0)$		-20 mA
$I_{OK}$	Output clamp current	$(V_O < 0 \text{ or } V_O > V_{CC})$		±20 mA
$I_O$	Continuous output current	$(V_O = 0 \text{ to } V_{CC})$		±25 mA
	Continuous current through $V_{CC}$ or GND			±50 mA
$T_{stg}$	Storage temperature range	-65	150	°C

(1) Stresses beyond those listed under “absolute maximum ratings” may cause permanent damage to the device. These are stress ratings only, and functional operation of the device at these or any other conditions beyond those indicated under “recommended operating conditions” is not implied. Exposure to absolute-maximum-rated conditions for extended periods may affect device reliability.

(2) Voltage values are with respect to the network ground terminal.

(3) The input and output voltage ratings may be exceeded if the input and output current ratings are observed.

### 4.2 ESD Ratings

		VALUE	UNIT
$V_{(ESD)}$ Electrostatic discharge	Human body model (HBM), per ANSI/ESDA/JEDEC JS-001, all pins <sup>(1)</sup>	±2000	V
	Charged device model (CDM), per JEDEC specification JESD22-C101, all pins <sup>(2)</sup>	±1000	

(1) JEDEC document JEP155 states that 500-V HBM allows safe manufacturing with a standard ESD control process.

(2) JEDEC document JEP157 states that 250-V CDM allows safe manufacturing with a standard ESD control process.

### 4.3 Recommended Operating Conditions

over operating free-air temperature (unless otherwise noted)<sup>(1)</sup>

		SN54AHC123A		SN74AHC123A		UNIT
		MIN	MAX	MIN	MAX	
$V_{CC}$	Supply voltage	2	5.5	2	5.5	V
$V_{IH}$	High-level input voltage	$V_{CC} = 2 \text{ V}$	1.5	1.5		V
		$V_{CC} = 3 \text{ V}$	2.1	2.1		
		$V_{CC} = 5.5 \text{ V}$	3.85	3.85		
$V_{IL}$	Low-level input voltage	$V_{CC} = 2 \text{ V}$		0.5	0.5	V
		$V_{CC} = 3 \text{ V}$		0.9	0.9	
		$V_{CC} = 5.5 \text{ V}$		1.65	1.65	
$V_I$	Input voltage	0	5.5	0	5.5	V
$V_O$	Output voltage	0	$V_{CC}$	0	$V_{CC}$	V
$I_{OH}$	High-level output current	$V_{CC} = 2 \text{ V}$		-50	-50	μA
		$V_{CC} = 3.3 \text{ V} \pm 0.3 \text{ V}$		-4	-4	mA
		$V_{CC} = 5 \text{ V} \pm 0.5 \text{ V}$		-8	-8	
$I_{OL}$	Low-level output current	$V_{CC} = 2 \text{ V}$		50	50	μA
		$V_{CC} = 3.3 \text{ V} \pm 0.3 \text{ V}$		4	4	mA
		$V_{CC} = 5 \text{ V} \pm 0.5 \text{ V}$		8	8	
$R_{ext}$	External timing resistance	$V_{CC} = 2 \text{ V}$	5k	5k		Ω
		$V_{CC} > 3 \text{ V}$	1k	1k		
$\Delta t/\Delta V_{CC}$	Power-up ramp rate	1		1		ms/V

over operating free-air temperature (unless otherwise noted)<sup>(1)</sup>

		SN54AHC123A		SN74AHC123A		UNIT
		MIN	MAX	MIN	MAX	
T <sub>A</sub>	Operating free-air temperature	-55	125	-40	85	°C

(1) Unused R<sub>ext</sub>/C<sub>ext</sub> terminals should be left unconnected. All remaining unused inputs of the device must be held at V<sub>CC</sub> or GND to ensure proper device operation. Refer to the TI application report, *Implications of Slow or Floating CMOS Inputs*, literature number SCBA004.

#### 4.4 Thermal Information

THERMAL METRIC <sup>(1)</sup>		SNx4AHC123A					UNIT
		D (SOIC)	DB (SSOP)	DGV (TVSOP)	N (PDIP)	PW (TSSOP)	
		16 PINS	16 PINS	16 PINS	16 PINS	16 PINS	
R <sub>θJA</sub>	Junction-to-ambient thermal resistance	73	82	120	67	108	°C/W

(1) The package thermal impedance is calculated in accordance with JESD 51-7.

#### 4.5 Electrical Characteristics

over recommended operating free-air temperature range (unless otherwise noted)

PARAMETER	TEST CONDITIONS	V <sub>CC</sub>	T <sub>A</sub> = 25°C			SN54AHC123A		SN74AHC123A		UNIT
			MIN	TYP	MAX	MIN	MAX	MIN	MAX	
V <sub>OH</sub>	I <sub>OH</sub> = -50mA	2V	1.9	2		1.9		1.9	V	
		3V	2.9	3		2.9		2.9		
		4.5V	4.4	4.5		4.4		4.4		
	I <sub>OH</sub> = -4mA	3V	2.58		2.48		2.48			
	I <sub>OH</sub> = -8mA	4.5V	3.94		3.8		3.8			
V <sub>OL</sub>	I <sub>OL</sub> = 50mA	2V			0.1		0.1	0.1	V	
		3V			0.1		0.1	0.1		
		4.5V			0.1		0.1	0.1		
	I <sub>OL</sub> = 4mA	3V			0.36		0.5	0.44		
	I <sub>OL</sub> = 8mA	4.5V			0.36		0.5	0.44		
I <sub>I</sub>	R <sub>ext</sub> /C <sub>ext</sub> <sup>(2)</sup>	V <sub>I</sub> = V <sub>CC</sub> or GND	5.5V			±0.25		±2.5	±2.5	µA
	$\bar{A}$ , B, and $\overline{CLR}$	V <sub>I</sub> = V <sub>CC</sub> or GND	0V to 5.5V			±0.1		±1 <sup>(1)</sup>	±1	
I <sub>CC</sub>	Quiescent	V <sub>I</sub> = V <sub>CC</sub> or GND, I <sub>O</sub> = 0	5.5 V			4		40	40	µA
I <sub>CC</sub>	Active state (per circuit)	V <sub>I</sub> = V <sub>CC</sub> or GND, R <sub>ext</sub> /C <sub>ext</sub> = 0.5 V <sub>CC</sub>	3V		160	250		280	280	µA
			4.5V		280	500		650	650	
			5.5V		360	750		975	975	
C <sub>i</sub>		V <sub>I</sub> = V <sub>CC</sub> or GND	5V		1.9	10		10	pF	

(1) On products compliant to MIL-PRF-38535, this parameter is not production tested at V<sub>CC</sub> = 0 V.

(2) This test is performed with the terminal in the off-state condition.

#### 4.6 Timing Requirements, V<sub>CC</sub> = 3.3V ± 0.3V

over recommended operating free-air temperature range, V<sub>CC</sub> = 3.3 V ± 0.3 V (unless otherwise noted) (see [Load Circuit and Voltage Waveforms](#))

			TEST CONDITIONS	T <sub>A</sub> = 25°C			SN54AHC123A		SN74AHC123A		UNIT
				MIN	TYP	MAX	MIN	MAX	MIN	MAX	
t <sub>w</sub>	Pulse duration	$\overline{CLR}$		5			5		5	ns	
		$\bar{A}$ or B trigger		5			5		5		

**SN54AHC123A, SN74AHC123A**

SCLS352I – JULY 1997 – REVISED JANUARY 2025

 over recommended operating free-air temperature range,  $V_{CC} = 3.3\text{ V} \pm 0.3\text{ V}$  (unless otherwise noted) (see [Load Circuit and Voltage Waveforms](#))

		TEST CONDITIONS	$T_A = 25^\circ\text{C}$			SN54AHC123A		SN74AHC123A		UNIT
			MIN	TYP	MAX	MIN	MAX	MIN	MAX	
$t_{rr}$	Pulse retrigger time	$R_{ext} = 1\text{ k}\Omega$ , $C_{ext} = 100\text{ pF}$	(1)	76		(1)		(1)		ns
		$R_{ext} = 1\text{ k}\Omega$ , $C_{ext} = 0.01\text{ }\mu\text{F}$	(1)	1.8		(1)		(1)		$\mu\text{s}$

 (1) See retriggering data in the *application information* section.

**4.7 Timing Requirements,  $V_{CC} = 5\text{ V} \pm 0.5\text{ V}$** 

 over recommended operating free-air temperature range,  $V_{CC} = 5\text{ V} \pm 0.5\text{ V}$  (unless otherwise noted) (see [Load Circuit and Voltage Waveforms](#))

			TEST CONDITIONS	$T_A = 25^\circ\text{C}$			SN54AHC123A		SN74AHC123A		UNIT
				MIN	TYP	MAX	MIN	MAX	MIN	MAX	
$t_w$	Pulse duration	$\overline{\text{CLR}}$		5		5		5		ns	
		$\overline{\text{A}}$ or B trigger		5		5		5			
$t_{rr}$	Pulse retrigger time	$R_{ext} = 1\text{ k}\Omega$ , $C_{ext} = 100\text{ pF}$	(1)	59		(1)		(1)		ns	
		$R_{ext} = 1\text{ k}\Omega$ , $C_{ext} = 0.01\text{ }\mu\text{F}$	(1)	1.5		(1)		(1)		$\mu\text{s}$	

 (1) See retriggering data in the *application information* section.

**4.8 Switching Characteristics,  $V_{CC} = 3.3\text{ V} \pm 0.3\text{ V}$** 

 over recommended operating free-air temperature range,  $V_{CC} = 3.3\text{ V} \pm 0.3\text{ V}$  (unless otherwise noted) (see [Load Circuit and Voltage Waveforms](#))

PARAMETER	FROM (INPUT)	TO (OUTPUT)	TEST CONDITIONS	$T_A = 25^\circ\text{C}$			SN54AHC123A		SN74AHC123A		UNIT		
				MIN	TYP	MAX	MIN	MAX	MIN	MAX			
$t_{PLH}$	$\overline{\text{A}}$ or B	Q or $\overline{\text{Q}}$	$C_L = 15\text{ pF}$	9.5 <sup>(1)</sup>	20.6 <sup>(1)</sup>		1 <sup>(1)</sup>	24 <sup>(1)</sup>	1	24	ns		
$t_{PHL}$				10.2 <sup>(1)</sup>	20.6 <sup>(1)</sup>		1 <sup>(1)</sup>	24 <sup>(1)</sup>	1	24			
$t_{PLH}$	$\overline{\text{CLR}}$	Q or $\overline{\text{Q}}$	$C_L = 15\text{ pF}$	7.5 <sup>(1)</sup>	15.8 <sup>(1)</sup>		1 <sup>(1)</sup>	18.5 <sup>(1)</sup>	1	18.5	ns		
$t_{PHL}$				9.3 <sup>(1)</sup>	15.8 <sup>(1)</sup>		1 <sup>(1)</sup>	18.5 <sup>(1)</sup>	1	18.5			
$t_{PLH}$	$\overline{\text{CLR}}$ trigger	Q or $\overline{\text{Q}}$	$C_L = 15\text{ pF}$	10 <sup>(1)</sup>	22.4 <sup>(1)</sup>		1 <sup>(1)</sup>	26 <sup>(1)</sup>	1	26	ns		
$t_{PHL}$				10.6 <sup>(1)</sup>	22.4 <sup>(1)</sup>		1 <sup>(1)</sup>	26 <sup>(1)</sup>	1	26			
$t_{PLH}$	$\overline{\text{A}}$ or B	Q or $\overline{\text{Q}}$	$C_L = 50\text{ pF}$	10.5	24.1		1	27.5	1	27.5	ns		
$t_{PHL}$				11.8	24.1		1	27.5	1	27.5			
$t_{PLH}$	$\overline{\text{CLR}}$	Q or $\overline{\text{Q}}$	$C_L = 50\text{ pF}$	8.9	19.3		1	22	1	22	ns		
$t_{PHL}$				10.5	19.3		1	22	1	22			
$t_{PLH}$	$\overline{\text{CLR}}$ trigger	Q or $\overline{\text{Q}}$	$C_L = 50\text{ pF}$	11	25.9		1	29.5	1	29.5	ns		
$t_{PHL}$				12.3	25.9		1	29.5	1	29.5			
$t_w$ <sup>(2)</sup>		Q or $\overline{\text{Q}}$	$C_L = 50\text{ pF}$ , $C_{ext} = 28\text{ pF}$ , $R_{ext} = 2\text{ k}\Omega$	182	240			300		300	ns		
			$C_L = 50\text{ pF}$ , $C_{ext} = 0.01\text{ }\mu\text{F}$ , $R_{ext} = 10\text{ k}\Omega$	90	100	110		90	110		90	110	$\mu\text{s}$
			$C_L = 50\text{ pF}$ , $C_{ext} = 0.1\text{ }\mu\text{F}$ , $R_{ext} = 10\text{ k}\Omega$	0.9	1	1.1		0.9	1.1		0.9	1.1	ms
$\Delta t_w$ <sup>(3)</sup>					$\pm 1$						%		

(1) On products compliant to MIL-PRF-38535, this parameter is not production tested.

 (2)  $t_w$  = Pulse duration at Q and  $\overline{\text{Q}}$  outputs

 (3)  $\Delta t_w$  = Output pulse-duration variation (Q and  $\overline{\text{Q}}$ ) between circuits in same package

## 4.9 Switching Characteristics, $V_{CC} = 5V \pm 0.5V$

over recommended operating free-air temperature range,  $V_{CC} = 5V \pm 0.5V$  (unless otherwise noted) (see [Load Circuit and Voltage Waveforms](#))

PARAMETER	FROM (INPUT)	TO (OUTPUT)	TEST CONDITIONS	$T_A = 25^\circ\text{C}$			SN54AHC123A		SN74AHC123A		UNIT
				MIN	TYP	MAX	MIN	MAX	MIN	MAX	
$t_{PLH}$	$\bar{A}$ or B	Q or $\bar{Q}$	$C_L = 15\text{ pF}$	6.5 <sup>(1)</sup>	12 <sup>(1)</sup>		1 <sup>(1)</sup>	14 <sup>(1)</sup>	1	14	ns
$t_{PHL}$				7.1 <sup>(1)</sup>	12 <sup>(1)</sup>		1 <sup>(1)</sup>	14 <sup>(1)</sup>	1	14	
$t_{PLH}$	$\overline{\text{CLR}}$	Q or $\bar{Q}$	$C_L = 15\text{ pF}$	5.3 <sup>(1)</sup>	9.4 <sup>(1)</sup>		1 <sup>(1)</sup>	11 <sup>(1)</sup>	1	11	ns
$t_{PHL}$				6.5 <sup>(1)</sup>	9.4 <sup>(1)</sup>		1 <sup>(1)</sup>	11 <sup>(1)</sup>	1	11	
$t_{PLH}$	$\overline{\text{CLR}}$ trigger	Q or $\bar{Q}$	$C_L = 15\text{ pF}$	6.9 <sup>(1)</sup>	12.9 <sup>(1)</sup>		1 <sup>(1)</sup>	15 <sup>(1)</sup>	1	15	ns
$t_{PHL}$				7.4 <sup>(1)</sup>	12.9 <sup>(1)</sup>		1 <sup>(1)</sup>	15 <sup>(1)</sup>	1	15	
$t_{PLH}$	$\bar{A}$ or B	Q or $\bar{Q}$	$C_L = 50\text{ pF}$	7.3	14		1	16	1	16	ns
$t_{PHL}$				8.3	14		1	16	1	16	
$t_{PLH}$	$\overline{\text{CLR}}$	Q or $\bar{Q}$	$C_L = 50\text{ pF}$	6.3	11.4		1	13	1	13	ns
$t_{PHL}$				7.4	11.4		1	13	1	13	
$t_{PLH}$	$\overline{\text{CLR}}$ trigger	Q or $\bar{Q}$	$C_L = 50\text{ pF}$	7.6	14.9		1	17	1	17	ns
$t_{PHL}$				8.7	14.9		1	17	1	17	
$t_w$ <sup>(2)</sup>		Q or $\bar{Q}$	$C_L = 50\text{ pF}, C_{\text{ext}} = 28\text{ pF}, R_{\text{ext}} = 2\text{ k}\Omega$	167	200			240		240	ns
			$C_L = 50\text{ pF}, C_{\text{ext}} = 0.01\text{ }\mu\text{F}, R_{\text{ext}} = 10\text{ k}\Omega$	90	100	110	90	110	90	110	$\mu\text{s}$
			$C_L = 50\text{ pF}, C_{\text{ext}} = 0.1\text{ }\mu\text{F}, R_{\text{ext}} = 10\text{ k}\Omega$	0.9	1	1.1	0.9	1.1	0.9	1.1	ms
$\Delta t_w$ <sup>(3)</sup>				$\pm 1$						%	

(1) On products compliant to MIL-PRF-38535, this parameter is not production tested.

(2)  $t_w$  = Pulse duration at Q and  $\bar{Q}$  outputs

(3)  $\Delta t_w$  = Output pulse-duration variation (Q and  $\bar{Q}$ ) between circuits in same package

## 4.10 Operating Characteristics

$V_{CC} = 5V, T_A = 25^\circ\text{C}$

PARAMETER	TEST CONDITIONS	TYP	UNIT	
$C_{pd}$	Power dissipation capacitance	No load	29	pF

### 4.11 Input/Output Timing Diagram

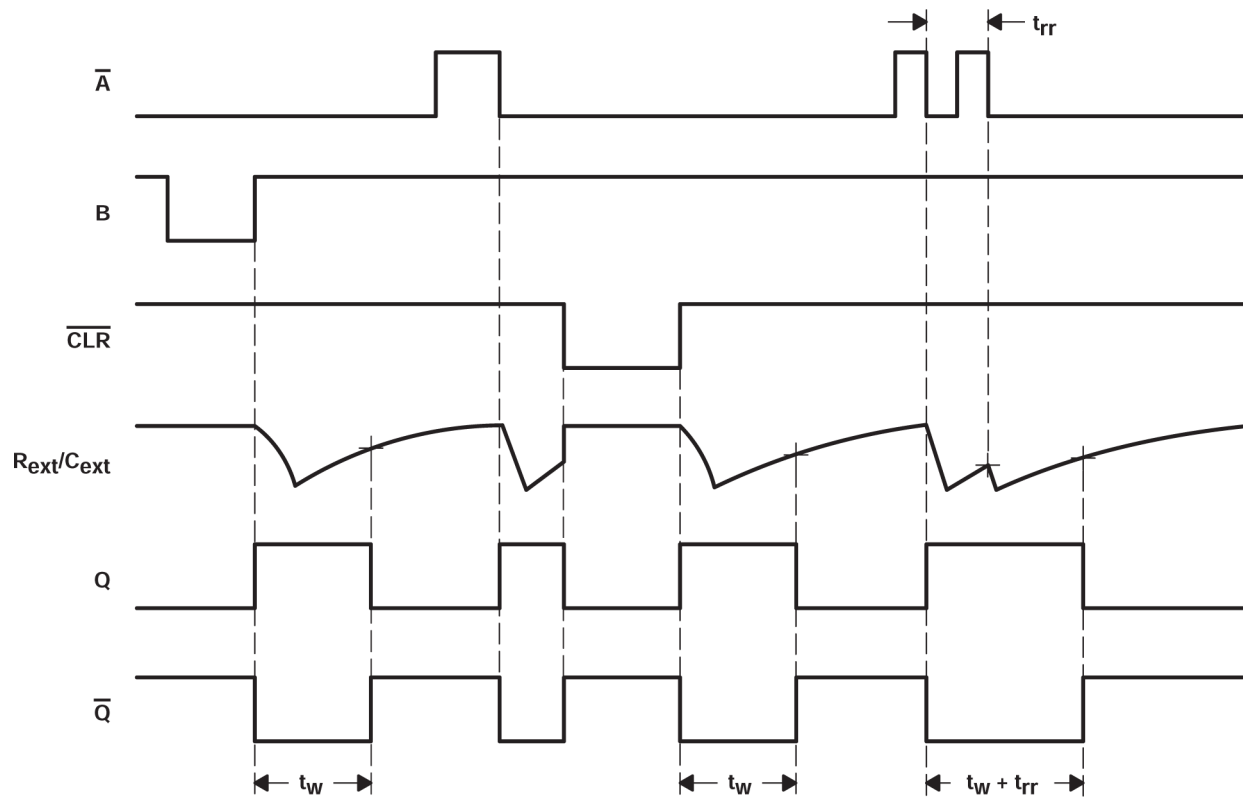

## 5 Parameter Measurement Information

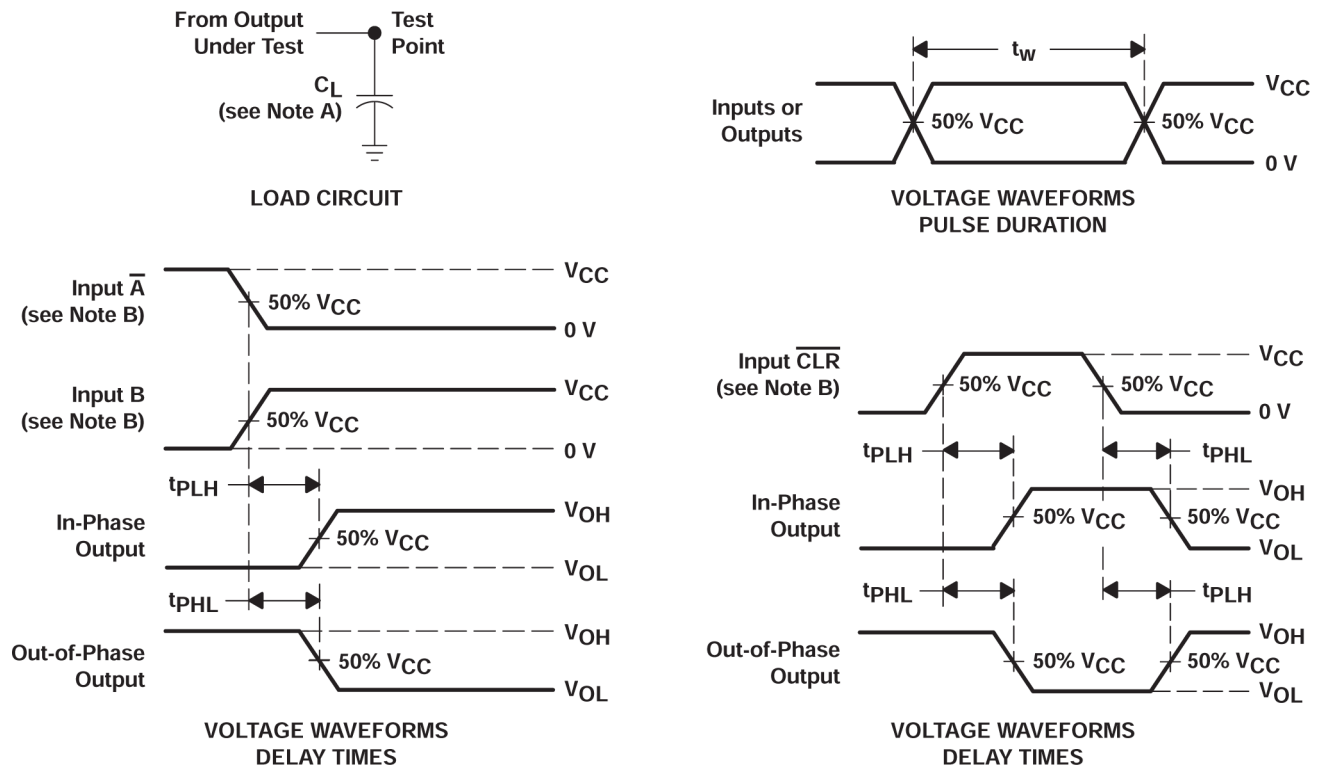

- A.  $C_L$  includes probe and jig capacitance.
- B. All input pulses are supplied by generators having the following characteristics:  $Z_O = 50\ \Omega$ ,  $t_r + 3\text{ ns}$ ,  $t_f + 3\text{ ns}$ .
- C. The outputs are measured one at a time, with one input transition per measurement.

**Figure 5-1. Load Circuit and Voltage Waveforms**

## 6 Detailed Description

### 6.1 Overview

These edge-triggered multivibrators feature output pulse-duration control by three methods. In the first method, the  $\bar{A}$  input is low, and the B input goes high. In the second method, the B input is high, and the  $\bar{A}$  input goes low. In the third method, the  $\bar{A}$  input is low, the B input is high, and the clear ( $\overline{\text{CLR}}$ ) input goes high.

The output pulse duration is programmed by selecting external resistance and capacitance values. The external timing capacitor must be connected between  $C_{\text{ext}}$  and  $R_{\text{ext}}/C_{\text{ext}}$  (positive) and an external resistor connected between  $R_{\text{ext}}/C_{\text{ext}}$  and  $V_{\text{CC}}$ . To obtain variable pulse durations, connect an external variable resistance between  $R_{\text{ext}}/C_{\text{ext}}$  and  $V_{\text{CC}}$ . The output pulse duration also can be reduced by taking  $\overline{\text{CLR}}$  low.

Pulse triggering occurs at a particular voltage level and is not directly related to the transition time of the input pulse. The  $\bar{A}$ , B, and  $\overline{\text{CLR}}$  inputs have Schmitt-triggers with sufficient hysteresis to handle slow input transition rates with jitter-free triggering at the outputs.

Once triggered, the basic pulse duration can be extended by retriggering the gated low-level-active ( $\bar{A}$ ) or high-level-active (B) input. Pulse duration can be reduced by taking  $\overline{\text{CLR}}$  low.  $\overline{\text{CLR}}$  input can be used to override  $\bar{A}$  or B inputs. The input/output timing diagram illustrates pulse control by retriggering the inputs and early clearing.

The variance in output pulse duration from device to device typically is less than  $\pm 0.5\%$  for given external timing components. An example of this distribution for the 'AHC123A is shown in Figure 7-9. Variations in output pulse duration versus supply voltage and temperature are shown in Figure 7-5.

During power up, Q outputs are in the low state, and  $\bar{Q}$  outputs are in the high state. The outputs are glitch free, without applying a reset pulse.

For additional application information on multivibrators, see the application report *Designing With the SN74AHC123A and SN74AHCT123A*, literature number SCLA014.

### 6.2 Functional Block Diagram

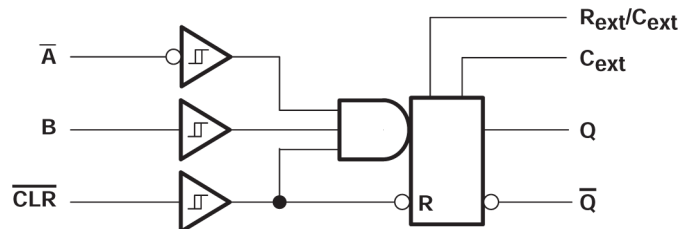







Figure 6-1. Logic Diagram, Each Multivibrator (Positive Logic)

### 6.3 Device Functional Modes

Table 6-1. Function Table (Each Multivibrator)

INPUTS			OUTPUTS	
CLR	A	B	Q	$\bar{Q}$
L	X	X	L	H
X	H	X	L <sup>(1)</sup>	H <sup>(1)</sup>
X	X	L	L <sup>(1)</sup>	H <sup>(1)</sup>
H	L	↑		
H	↓	H		
↑	L	H		

- (1) These outputs are based on the assumption that the indicated steady-state conditions at the  $\bar{A}$  and B inputs have been set up long enough to complete any pulse started before the setup.

## 7 Application and Implementation

### Note

Information in the following applications sections is not part of the TI component specification, and TI does not warrant its accuracy or completeness. TI's customers are responsible for determining suitability of components for their purposes, as well as validating and testing their design implementation to confirm system functionality.

### 7.1 Application Information

Operation of the device at these or any other conditions beyond those indicated under “recommended operating conditions” is not implied.

#### 7.1.1 Caution in Use

To prevent malfunctions due to noise, connect a high-frequency capacitor between  $V_{CC}$  and GND, and keep the wiring between the external components and  $C_{ext}$  and  $R_{ext}/C_{ext}$  terminals as short as possible.

#### 7.1.2 Output Pulse Duration

The output pulse duration,  $t_w$ , is determined primarily by the values of the external capacitance ( $C_T$ ) and timing resistance ( $R_T$ ). The timing components are connected as shown in [Figure 7-1](#).

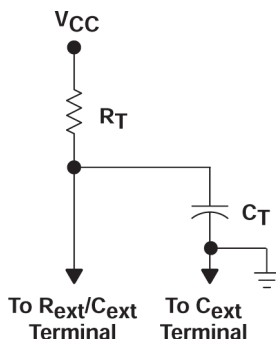

**Figure 7-1. Timing-Component Connections**

The pulse duration is given by:

$$t_w + K \times R_T \times C_T \quad (1)$$

if  $C_T$  is  $\geq 1000$  pF,  $K = 1.0$  or

if  $C_T$  is  $< 1000$  pF,  $K$  can be determined from [Figure 7-6](#)

where:

$t_w$  = pulse duration in ns

$R_T$  = external timing resistance in  $k\Omega$

$C_T$  = external capacitance in pF

$K$  = multiplier factor

[Figure 5-1](#) and [Figure 7-2](#) can be used to determine values for pulse duration, external resistance, and external capacitance.

#### 7.1.3 Power-down Considerations

Large values of  $C_{ext}$  can cause problems when powering down the 'AHC123A devices because of the amount of energy stored in the capacitor. When a system containing this device is powered down, the capacitor can discharge from  $V_{CC}$  through the protection diodes at pin 2 or pin 14. Current through the input protection diodes

must be limited to 30 mA; therefore, the turn-off time of the  $V_{CC}$  power supply must not be faster than  $t = V_{CC} \times C_{ext}/30 \text{ mA}$ . For example, if  $V_{CC} = 5 \text{ V}$  and  $C_{ext} = 15 \text{ pF}$ , the  $V_{CC}$  supply must turn off no faster than  $t = (5 \text{ V}) \times (15 \text{ pF})/30 \text{ mA} = 2.5 \text{ ns}$ . Usually, this is not a problem because power supplies are heavily filtered and cannot discharge at this rate. When a more rapid decrease of  $V_{CC}$  to zero occurs, the 'AHC123A devices can sustain damage. To avoid this possibility, use external clamping diodes.

### 7.1.4 Retriggering Data

The minimum input retriggering time ( $t_{MIR}$ ) is the minimum time required after the initial signal before retriggering the input. After  $t_{MIR}$ , the device retriggers the output. Experimentally, it also can be shown that to retrigger the output pulse, the two adjacent input signals should be  $t_{MIR}$  apart, where  $t_{MIR} = 0.30 \times t_w$ . The retrigger pulse duration is calculated as shown in Figure 7-2.

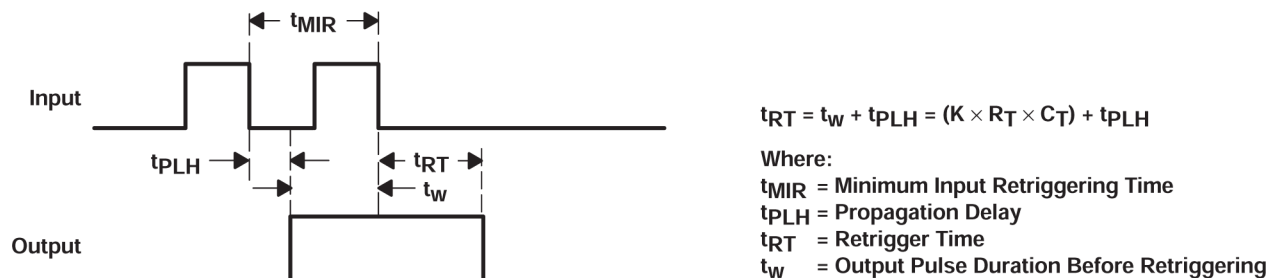

Figure 7-2. Retrigger Pulse Duration

The minimum value from the end of the input pulse to the beginning of the retriggered output should be approximately 15 ns to ensure a retriggered output (see Figure 7-3).

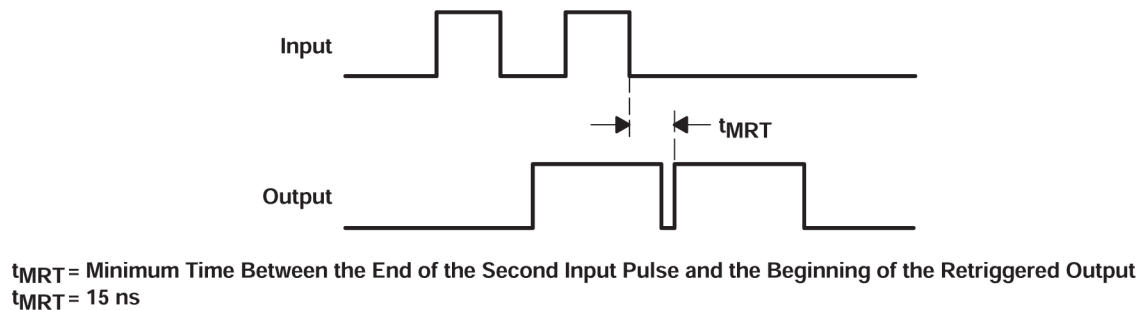
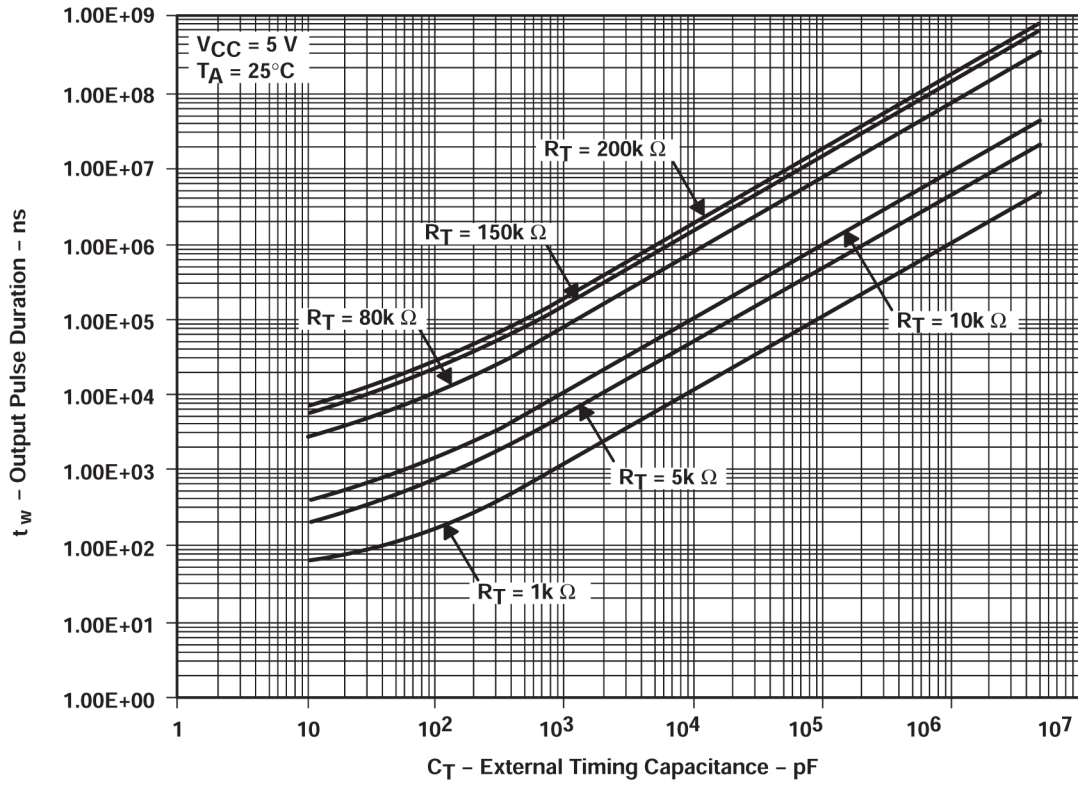
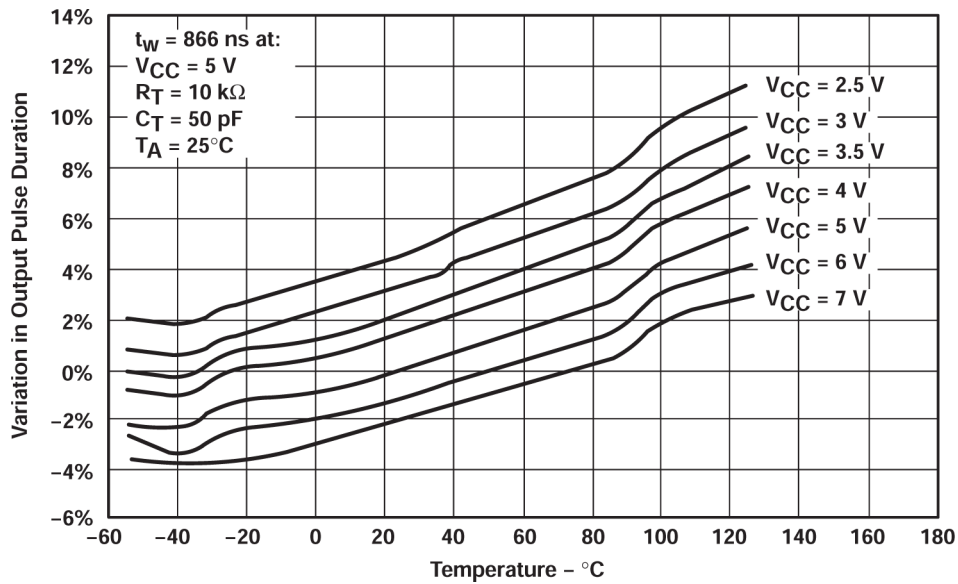

Figure 7-3. Input/Output Requirements



**Figure 7-4. Output Pulse Duration vs External Timing Capacitance**



**Figure 7-5. Variations in Output Pulse Duration vs Temperature**

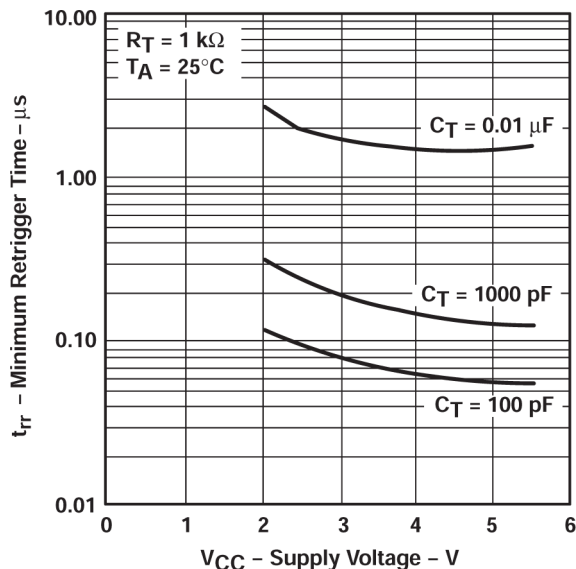

**Figure 7-6. Minimum Trigger Time vs  $V_{CC}$  Characteristics**

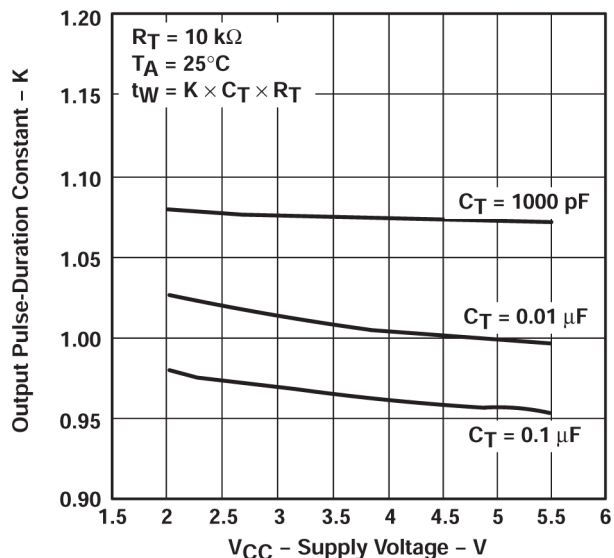

**Figure 7-7. Output Pulse-duration Constant vs Supply Voltage**

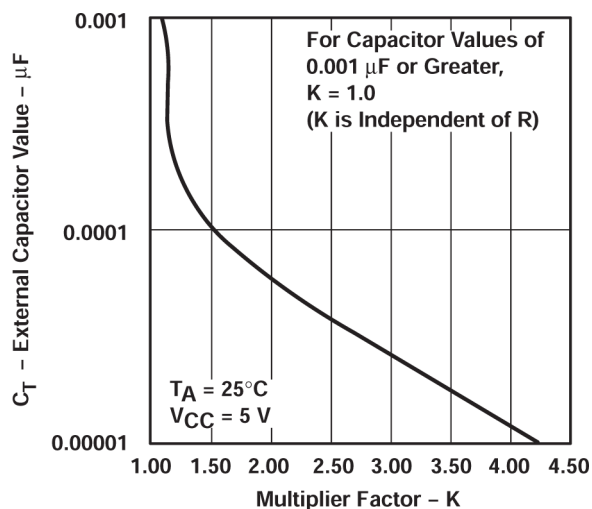

**Figure 7-8. External Capacitance vs Multiplier Factor**

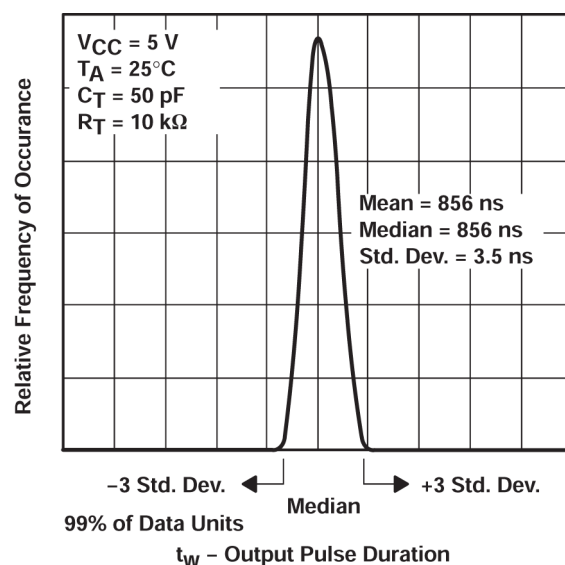

**Figure 7-9. Distribution of Units vs Output Pulse Duration**

## 7.2 Power Supply Recommendations

The power supply can be any voltage between the minimum and maximum supply voltage rating located in the *Recommended Operating Conditions*. Each  $V_{CC}$  terminal should have a good bypass capacitor to prevent power disturbance. A  $0.1\mu\text{F}$  capacitor is recommended for this device. It is acceptable to parallel multiple bypass capacitors to reject different frequencies of noise. The  $0.1\mu\text{F}$  and  $1\mu\text{F}$  capacitors are commonly used in parallel. The bypass capacitor should be installed as close to the power terminal as possible for best results.

## 7.3 Layout

### 7.3.1 Layout Guidelines

- Bypass capacitor placement

- Place near the positive supply terminal of the device
- Provide an electrically short ground return path
- Use wide traces to minimize impedance
- Keep the device, capacitors, and traces on the same side of the board whenever possible
- Signal trace geometry
  - 8mil to 12mil trace width
  - Lengths less than 12cm to minimize transmission line effects
  - Avoid 90° corners for signal traces
  - Use an unbroken ground plane below signal traces
  - Flood fill areas around signal traces with ground
  - For traces longer than 12cm
    - Use impedance controlled traces
    - Source-terminate using a series damping resistor near the output
    - Avoid branches; buffer signals that must branch separately

### 7.3.2 Layout Example

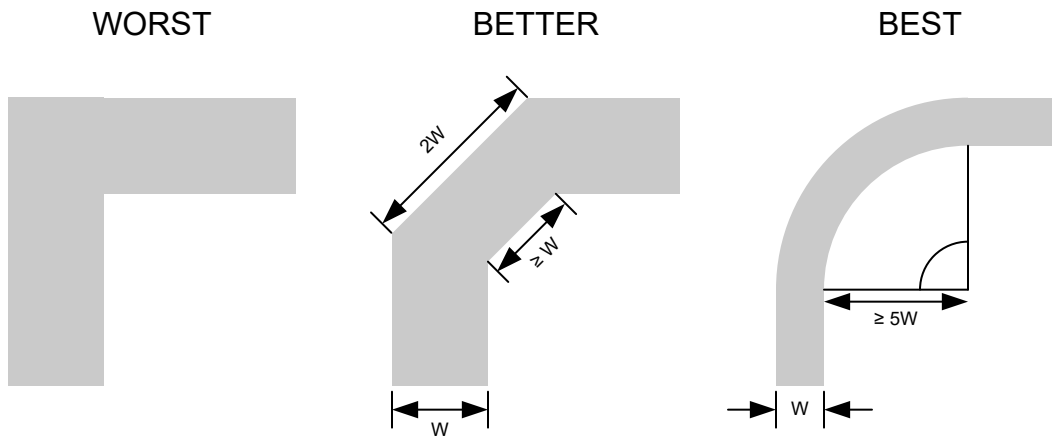

**Figure 7-10. Example Trace Corners for Improved Signal Integrity**

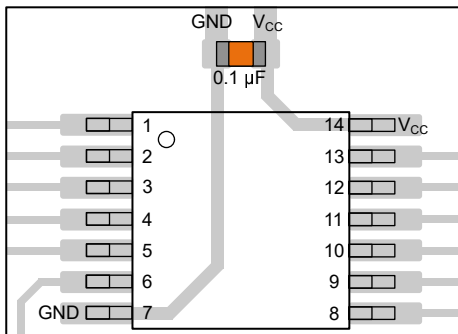

**Figure 7-11. Example Bypass Capacitor Placement for TSSOP and Similar Packages**

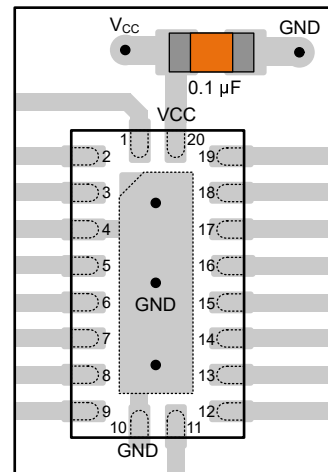

**Figure 7-12. Example Bypass Capacitor Placement for WQFN and Similar Packages**

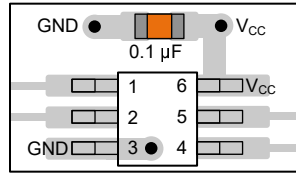

**Figure 7-13. Example Bypass Capacitor Placement for SOT, SC70 and Similar Packages**

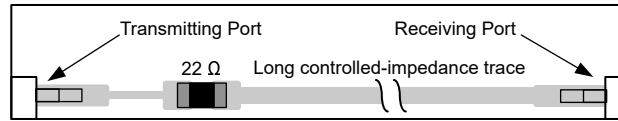

**Figure 7-14. Example Damping Resistor Placement for Improved Signal Integrity**

## 8 Device and Documentation Support

TI offers an extensive line of development tools. Tools and software to evaluate the performance of the device, generate code, and develop solutions are listed below.

### 8.1 Documentation Support

#### 8.1.1 Related Documentation

For related documentation, see the following:

- Texas Instruments, [CMOS Power Consumption and  \$C\_{pd}\$  Calculation application report](#)
- Texas Instruments, [Designing With Logic application report](#)
- Texas Instruments, [Thermal Characteristics of Standard Linear and Logic \(SLL\) Packages and Devices application report](#)

### 8.2 Receiving Notification of Documentation Updates

To receive notification of documentation updates, navigate to the device product folder on [ti.com](#). Click on *Notifications* to register and receive a weekly digest of any product information that has changed. For change details, review the revision history included in any revised document.

### 8.3 Support Resources

TI E2E™ [support forums](#) are an engineer's go-to source for fast, verified answers and design help — straight from the experts. Search existing answers or ask your own question to get the quick design help you need.

Linked content is provided "AS IS" by the respective contributors. They do not constitute TI specifications and do not necessarily reflect TI's views; see TI's [Terms of Use](#).

### 8.4 Trademarks

TI E2E™ is a trademark of Texas Instruments.  
All trademarks are the property of their respective owners.

### 8.5 Electrostatic Discharge Caution



This integrated circuit can be damaged by ESD. Texas Instruments recommends that all integrated circuits be handled with appropriate precautions. Failure to observe proper handling and installation procedures can cause damage.

ESD damage can range from subtle performance degradation to complete device failure. Precision integrated circuits may be more susceptible to damage because very small parametric changes could cause the device not to meet its published specifications.

### 8.6 Glossary

[TI Glossary](#) This glossary lists and explains terms, acronyms, and definitions.

## 9 Revision History

NOTE: Page numbers for previous revisions may differ from page numbers in the current version.

<b>Changes from Revision H (October 2005) to Revision I (January 2025)</b>	<b>Page</b>
• Added <i>Device Information</i> table, <i>Pin Functions</i> table, <i>ESD Ratings</i> table, <i>Thermal Information</i> table, <i>Device Functional Modes</i> , Application and Implementation section, <i>Device and Documentation Support</i> section, and <i>Mechanical, Packaging, and Orderable Information</i> section .....	<b>1</b>
• Deleted references to machine model throughout data sheet.....	<b>4</b>

## 10 Mechanical, Packaging, and Orderable Information

The following pages include mechanical, packaging, and orderable information. This information is the most current data available for the designated devices. This data is subject to change without notice and revision of this document. For browser-based versions of this data sheet, refer to the left-hand navigation.

**PACKAGING INFORMATION**

Orderable part number	Status (1)	Material type (2)	Package   Pins	Package qty   Carrier	RoHS (3)	Lead finish/ Ball material (4)	MSL rating/ Peak reflow (5)	Op temp (°C)	Part marking (6)
<a href="#">5962-9860801Q2A</a>	Active	Production	LCCC (FK)   20	55   TUBE	No	SNPB	N/A for Pkg Type	-55 to 125	5962- 9860801Q2A SNJ54AHC 123AFK
<a href="#">5962-9860801QEA</a>	Active	Production	CDIP (J)   16	25   TUBE	No	SNPB	N/A for Pkg Type	-55 to 125	5962-9860801QE A SNJ54AHC123AJ
<a href="#">5962-9860801QFA</a>	Active	Production	CFP (W)   16	25   TUBE	No	SNPB	N/A for Pkg Type	-55 to 125	5962-9860801QF A SNJ54AHC123AW
<a href="#">SN74AHC123AD</a>	Obsolete	Production	SOIC (D)   16	-	-	Call TI	Call TI	-40 to 85	AHC123A
<a href="#">SN74AHC123ADBR</a>	Active	Production	SSOP (DB)   16	2000   LARGE T&R	Yes	NIPDAU	Level-1-260C-UNLIM	-40 to 85	HA123A
<a href="#">SN74AHC123ADBR.A</a>	Active	Production	SSOP (DB)   16	2000   LARGE T&R	Yes	NIPDAU	Level-1-260C-UNLIM	-40 to 85	HA123A
<a href="#">SN74AHC123ADGVR</a>	Active	Production	TVSOP (DGV)   16	2000   LARGE T&R	Yes	NIPDAU	Level-1-260C-UNLIM	-40 to 85	HA123A
<a href="#">SN74AHC123ADGVR.A</a>	Active	Production	TVSOP (DGV)   16	2000   LARGE T&R	Yes	NIPDAU	Level-1-260C-UNLIM	-40 to 85	HA123A
<a href="#">SN74AHC123ADGVRE4</a>	Active	Production	TVSOP (DGV)   16	2000   LARGE T&R	Yes	NIPDAU	Level-1-260C-UNLIM	-40 to 85	HA123A
<a href="#">SN74AHC123ADR</a>	Active	Production	SOIC (D)   16	2500   LARGE T&R	Yes	NIPDAU	Level-1-260C-UNLIM	-40 to 85	AHC123A
<a href="#">SN74AHC123ADR.A</a>	Active	Production	SOIC (D)   16	2500   LARGE T&R	Yes	NIPDAU	Level-1-260C-UNLIM	-40 to 85	AHC123A
<a href="#">SN74AHC123AN</a>	Active	Production	PDIP (N)   16	25   TUBE	Yes	NIPDAU	N/A for Pkg Type	-40 to 85	SN74AHC123AN
<a href="#">SN74AHC123AN.A</a>	Active	Production	PDIP (N)   16	25   TUBE	Yes	NIPDAU	N/A for Pkg Type	-40 to 85	SN74AHC123AN
<a href="#">SN74AHC123APWR</a>	Active	Production	TSSOP (PW)   16	2000   LARGE T&R	Yes	NIPDAU   SN	Level-1-260C-UNLIM	-40 to 85	HA123A
<a href="#">SN74AHC123APWR.A</a>	Active	Production	TSSOP (PW)   16	2000   LARGE T&R	Yes	NIPDAU	Level-1-260C-UNLIM	-40 to 85	HA123A
<a href="#">SN74AHC123APWRG4</a>	Active	Production	TSSOP (PW)   16	2000   LARGE T&R	Yes	NIPDAU	Level-1-260C-UNLIM	-40 to 85	HA123A
<a href="#">SN74AHC123APWRG4.A</a>	Active	Production	TSSOP (PW)   16	2000   LARGE T&R	Yes	NIPDAU	Level-1-260C-UNLIM	-40 to 85	HA123A
<a href="#">SNJ54AHC123AFK</a>	Active	Production	LCCC (FK)   20	55   TUBE	No	SNPB	N/A for Pkg Type	-55 to 125	5962- 9860801Q2A SNJ54AHC 123AFK
<a href="#">SNJ54AHC123AFK.A</a>	Active	Production	LCCC (FK)   20	55   TUBE	No	SNPB	N/A for Pkg Type	-55 to 125	5962- 9860801Q2A SNJ54AHC 123AFK

Orderable part number	Status (1)	Material type (2)	Package   Pins	Package qty   Carrier	RoHS (3)	Lead finish/ Ball material (4)	MSL rating/ Peak reflow (5)	Op temp (°C)	Part marking (6)
<a href="#">SNJ54AHC123AJ</a>	Active	Production	CDIP (J)   16	25   TUBE	No	SNPB	N/A for Pkg Type	-55 to 125	5962-9860801QE A SNJ54AHC123AJ
SNJ54AHC123AJ.A	Active	Production	CDIP (J)   16	25   TUBE	No	SNPB	N/A for Pkg Type	-55 to 125	5962-9860801QE A SNJ54AHC123AJ
<a href="#">SNJ54AHC123AW</a>	Active	Production	CFP (W)   16	25   TUBE	No	SNPB	N/A for Pkg Type	-55 to 125	5962-9860801QF A SNJ54AHC123AW
SNJ54AHC123AW.A	Active	Production	CFP (W)   16	25   TUBE	No	SNPB	N/A for Pkg Type	-55 to 125	5962-9860801QF A SNJ54AHC123AW

(1) **Status:** For more details on status, see our [product life cycle](#).

(2) **Material type:** When designated, preproduction parts are prototypes/experimental devices, and are not yet approved or released for full production. Testing and final process, including without limitation quality assurance, reliability performance testing, and/or process qualification, may not yet be complete, and this item is subject to further changes or possible discontinuation. If available for ordering, purchases will be subject to an additional waiver at checkout, and are intended for early internal evaluation purposes only. These items are sold without warranties of any kind.

(3) **RoHS values:** Yes, No, RoHS Exempt. See the [TI RoHS Statement](#) for additional information and value definition.

(4) **Lead finish/Ball material:** Parts may have multiple material finish options. Finish options are separated by a vertical ruled line. Lead finish/Ball material values may wrap to two lines if the finish value exceeds the maximum column width.

(5) **MSL rating/Peak reflow:** The moisture sensitivity level ratings and peak solder (reflow) temperatures. In the event that a part has multiple moisture sensitivity ratings, only the lowest level per JEDEC standards is shown. Refer to the shipping label for the actual reflow temperature that will be used to mount the part to the printed circuit board.

(6) **Part marking:** There may be an additional marking, which relates to the logo, the lot trace code information, or the environmental category of the part.

Multiple part markings will be inside parentheses. Only one part marking contained in parentheses and separated by a "~" will appear on a part. If a line is indented then it is a continuation of the previous line and the two combined represent the entire part marking for that device.

**Important Information and Disclaimer:** The information provided on this page represents TI's knowledge and belief as of the date that it is provided. TI bases its knowledge and belief on information provided by third parties, and makes no representation or warranty as to the accuracy of such information. Efforts are underway to better integrate information from third parties. TI has taken and continues to take reasonable steps to provide representative and accurate information but may not have conducted destructive testing or chemical analysis on incoming materials and chemicals. TI and TI suppliers consider certain information to be proprietary, and thus CAS numbers and other limited information may not be available for release.

In no event shall TI's liability arising out of such information exceed the total purchase price of the TI part(s) at issue in this document sold by TI to Customer on an annual basis.

**OTHER QUALIFIED VERSIONS OF SN54AHC123A, SN74AHC123A :**

- Catalog : [SN74AHC123A](#)
- Enhanced Product : [SN74AHC123A-EP](#), [SN74AHC123A-EP](#)
- Military : [SN54AHC123A](#)

NOTE: Qualified Version Definitions:

- Catalog - TI's standard catalog product
- Enhanced Product - Supports Defense, Aerospace and Medical Applications
- Military - QML certified for Military and Defense Applications

**TAPE AND REEL INFORMATION**

**QUADRANT ASSIGNMENTS FOR PIN 1 ORIENTATION IN TAPE**

\*All dimensions are nominal

Device	Package Type	Package Drawing	Pins	SPQ	Reel Diameter (mm)	Reel Width W1 (mm)	A0 (mm)	B0 (mm)	K0 (mm)	P1 (mm)	W (mm)	Pin1 Quadrant
SN74AHC123ADBR	SSOP	DB	16	2000	330.0	16.4	8.35	6.6	2.4	12.0	16.0	Q1
SN74AHC123ADGVR	TVSOP	DGV	16	2000	330.0	12.4	6.8	4.0	1.6	8.0	12.0	Q1
SN74AHC123ADR	SOIC	D	16	2500	330.0	16.4	6.5	10.3	2.1	8.0	16.0	Q1
SN74AHC123APWR	TSSOP	PW	16	2000	330.0	12.4	6.9	5.6	1.6	8.0	12.0	Q1
SN74AHC123APWRG4	TSSOP	PW	16	2000	330.0	12.4	6.9	5.6	1.6	8.0	12.0	Q1

**TAPE AND REEL BOX DIMENSIONS**

\*All dimensions are nominal

Device	Package Type	Package Drawing	Pins	SPQ	Length (mm)	Width (mm)	Height (mm)
SN74AHC123ADBR	SSOP	DB	16	2000	356.0	356.0	35.0
SN74AHC123ADGVR	TVSOP	DGV	16	2000	356.0	356.0	35.0
SN74AHC123ADR	SOIC	D	16	2500	353.0	353.0	32.0
SN74AHC123APWR	TSSOP	PW	16	2000	356.0	356.0	35.0
SN74AHC123APWRG4	TSSOP	PW	16	2000	367.0	367.0	35.0

**TUBE**

\*All dimensions are nominal

Device	Package Name	Package Type	Pins	SPQ	L (mm)	W (mm)	T (μm)	B (mm)
5962-9860801Q2A	FK	LCCC	20	55	506.98	12.06	2030	NA
5962-9860801QFA	W	CFP	16	25	506.98	26.16	6220	NA
SN74AHC123AN	N	PDIP	16	25	506	13.97	11230	4.32
SN74AHC123AN.A	N	PDIP	16	25	506	13.97	11230	4.32
SNJ54AHC123AFK	FK	LCCC	20	55	506.98	12.06	2030	NA
SNJ54AHC123AFK.A	FK	LCCC	20	55	506.98	12.06	2030	NA
SNJ54AHC123AW	W	CFP	16	25	506.98	26.16	6220	NA
SNJ54AHC123AW.A	W	CFP	16	25	506.98	26.16	6220	NA

DGV (R-PDSO-G\*\*)

PLASTIC SMALL-OUTLINE

24 PINS SHOWN



4073251/E 08/00

- NOTES: A. All linear dimensions are in millimeters.  
 B. This drawing is subject to change without notice.  
 C. Body dimensions do not include mold flash or protrusion, not to exceed 0,15 per side.  
 D. Falls within JEDEC: 24/48 Pins – MO-153  
 14/16/20/56 Pins – MO-194

W (R-GDFP-F16)

CERAMIC DUAL FLATPACK



- NOTES:
- A. All linear dimensions are in inches (millimeters).
  - B. This drawing is subject to change without notice.
  - C. This package can be hermetically sealed with a ceramic lid using glass frit.
  - D. Index point is provided on cap for terminal identification only.
  - E. Falls within MIL STD 1835 GDFP2-F16

## GENERIC PACKAGE VIEW

**FK 20**

**LCCC - 2.03 mm max height**

8.89 x 8.89, 1.27 mm pitch

LEADLESS CERAMIC CHIP CARRIER

This image is a representation of the package family, actual package may vary.  
Refer to the product data sheet for package details.



4229370VA\

J (R-GDIP-T\*\*)

14 LEADS SHOWN

CERAMIC DUAL IN-LINE PACKAGE



DIM \ PINS **	14	16	18	20
A	0.300 (7,62) BSC	0.300 (7,62) BSC	0.300 (7,62) BSC	0.300 (7,62) BSC
B MAX	0.785 (19,94)	.840 (21,34)	0.960 (24,38)	1.060 (26,92)
B MIN	—	—	—	—
C MAX	0.300 (7,62)	0.300 (7,62)	0.310 (7,87)	0.300 (7,62)
C MIN	0.245 (6,22)	0.245 (6,22)	0.220 (5,59)	0.245 (6,22)



4040083/F 03/03

- NOTES:
- All linear dimensions are in inches (millimeters).
  - This drawing is subject to change without notice.
  - This package is hermetically sealed with a ceramic lid using glass frit.
  - Index point is provided on cap for terminal identification only on press ceramic glass frit seal only.
  - Falls within MIL STD 1835 GDIP1-T14, GDIP1-T16, GDIP1-T18 and GDIP1-T20.

N (R-PDIP-T\*\*)

PLASTIC DUAL-IN-LINE PACKAGE

16 PINS SHOWN



- NOTES:
- A. All linear dimensions are in inches (millimeters).
  - B. This drawing is subject to change without notice.
  - Falls within JEDEC MS-001, except 18 and 20 pin minimum body length (Dim A).
  - The 20 pin end lead shoulder width is a vendor option, either half or full width.

D (R-PDSO-G16)

PLASTIC SMALL OUTLINE



- NOTES:
- A. All linear dimensions are in inches (millimeters).
  - B. This drawing is subject to change without notice.
  - C. Body length does not include mold flash, protrusions, or gate burrs. Mold flash, protrusions, or gate burrs shall not exceed 0.006 (0,15) each side.
  - D. Body width does not include interlead flash. Interlead flash shall not exceed 0.017 (0,43) each side.
  - E. Reference JEDEC MS-012 variation AC.

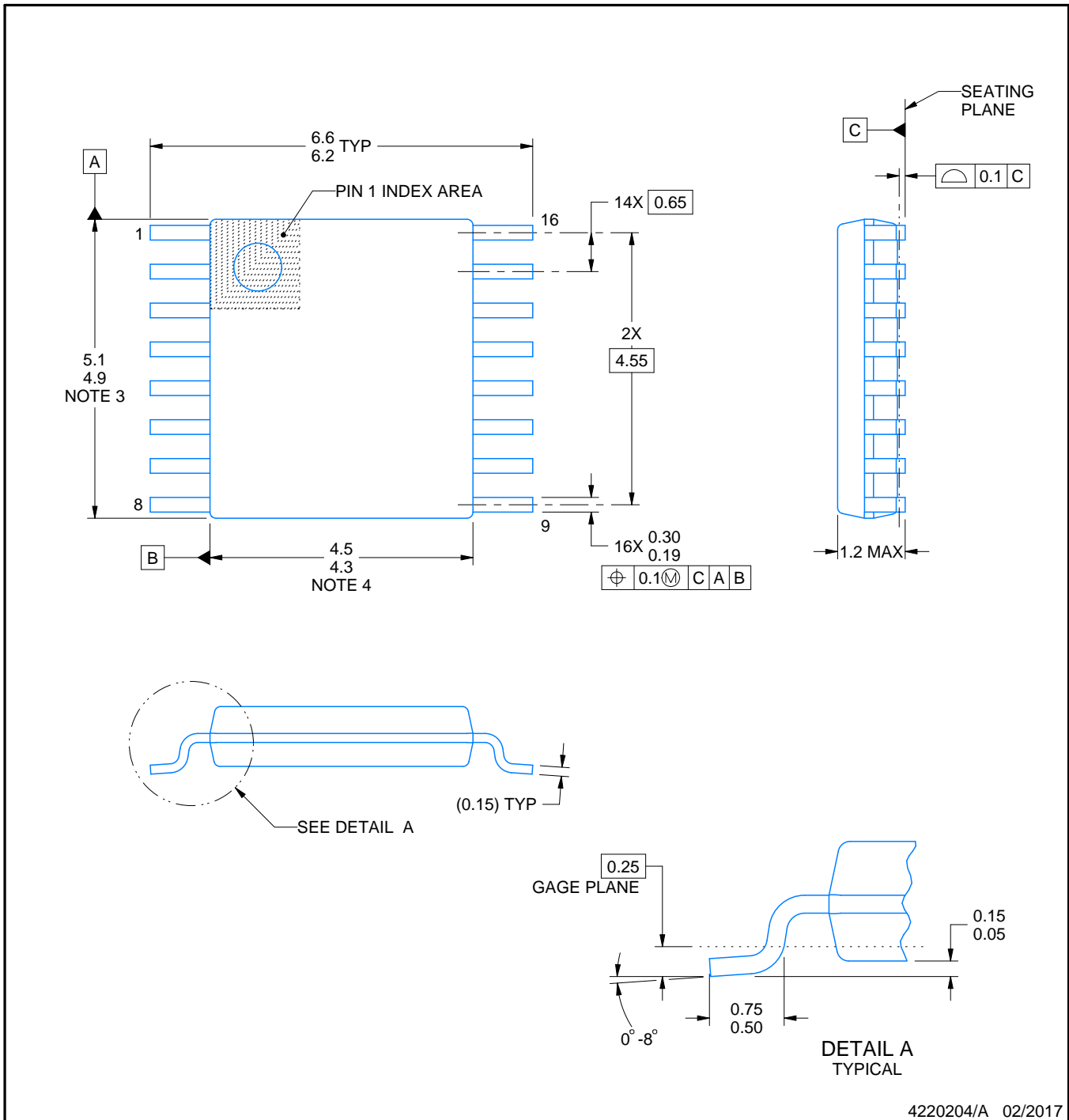

4220204/A 02/2017

NOTES:

1. All linear dimensions are in millimeters. Any dimensions in parenthesis are for reference only. Dimensioning and tolerancing per ASME Y14.5M.
2. This drawing is subject to change without notice.
3. This dimension does not include mold flash, protrusions, or gate burrs. Mold flash, protrusions, or gate burrs shall not exceed 0.15 mm per side.
4. This dimension does not include interlead flash. Interlead flash shall not exceed 0.25 mm per side.
5. Reference JEDEC registration MO-153.

# EXAMPLE BOARD LAYOUT

PW0016A

TSSOP - 1.2 mm max height

SMALL OUTLINE PACKAGE



LAND PATTERN EXAMPLE  
EXPOSED METAL SHOWN  
SCALE: 10X



SOLDER MASK DETAILS

4220204/A 02/2017

NOTES: (continued)

- 6. Publication IPC-7351 may have alternate designs.
- 7. Solder mask tolerances between and around signal pads can vary based on board fabrication site.

# EXAMPLE STENCIL DESIGN

PW0016A

TSSOP - 1.2 mm max height

SMALL OUTLINE PACKAGE

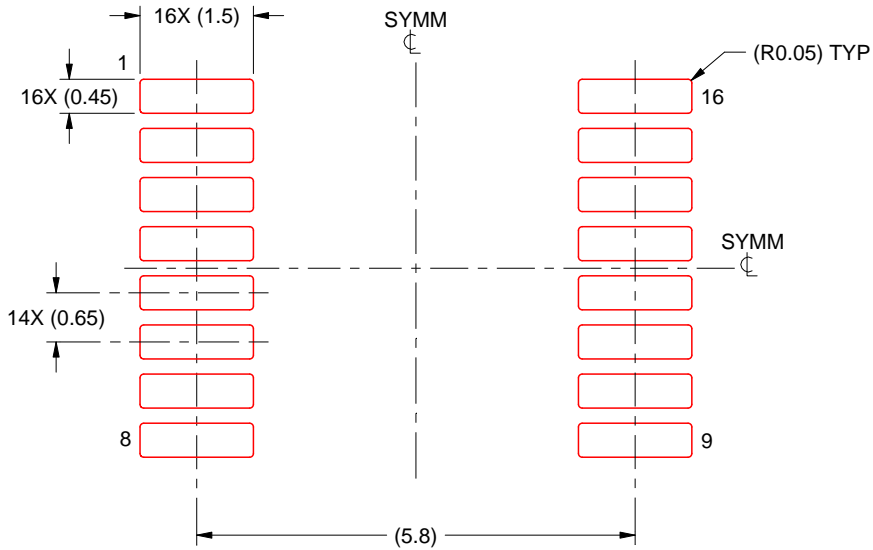

SOLDER PASTE EXAMPLE  
BASED ON 0.125 mm THICK STENCIL  
SCALE: 10X

4220204/A 02/2017

NOTES: (continued)

8. Laser cutting apertures with trapezoidal walls and rounded corners may offer better paste release. IPC-7525 may have alternate design recommendations.
9. Board assembly site may have different recommendations for stencil design.

# DB0016A



# PACKAGE OUTLINE

## SSOP - 2 mm max height

SMALL OUTLINE PACKAGE

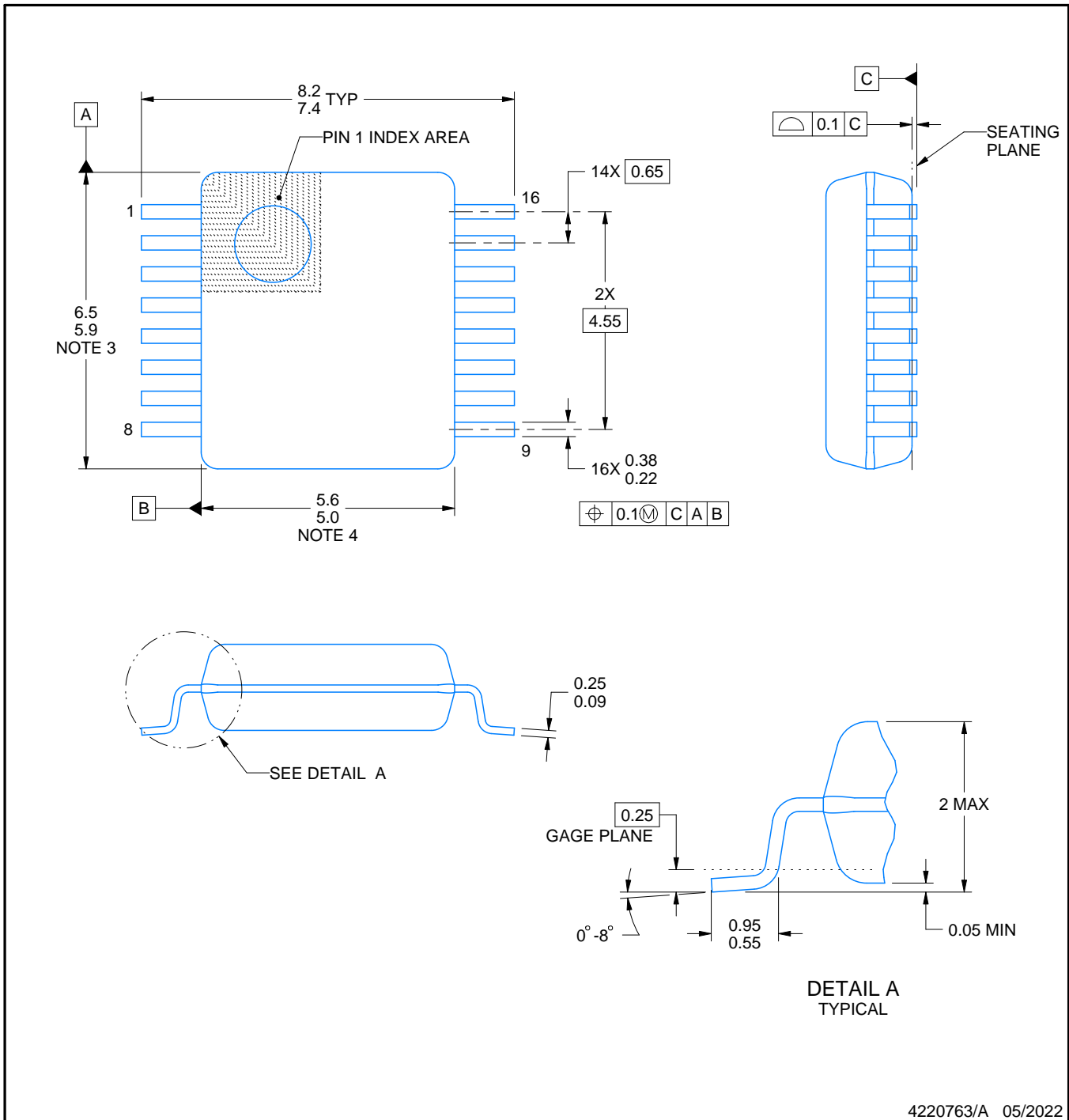

4220763/A 05/2022

**NOTES:**

1. All linear dimensions are in millimeters. Any dimensions in parenthesis are for reference only. Dimensioning and tolerancing per ASME Y14.5M.
2. This drawing is subject to change without notice.
3. This dimension does not include mold flash, protrusions, or gate burrs. Mold flash, protrusions, or gate burrs shall not exceed 0.15 mm per side.
4. Reference JEDEC registration MO-150.

# EXAMPLE BOARD LAYOUT

DB0016A

SSOP - 2 mm max height

SMALL OUTLINE PACKAGE

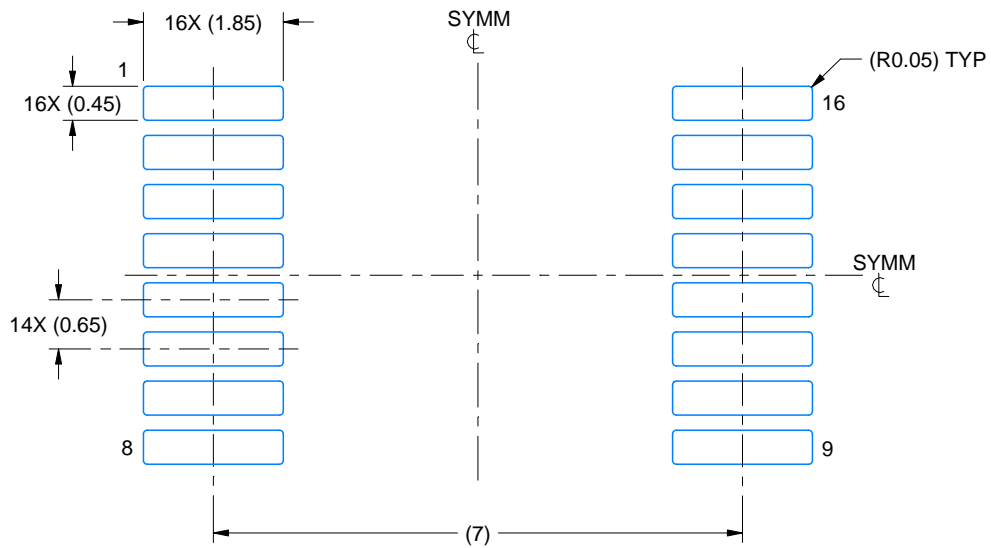

LAND PATTERN EXAMPLE  
EXPOSED METAL SHOWN  
SCALE: 10X

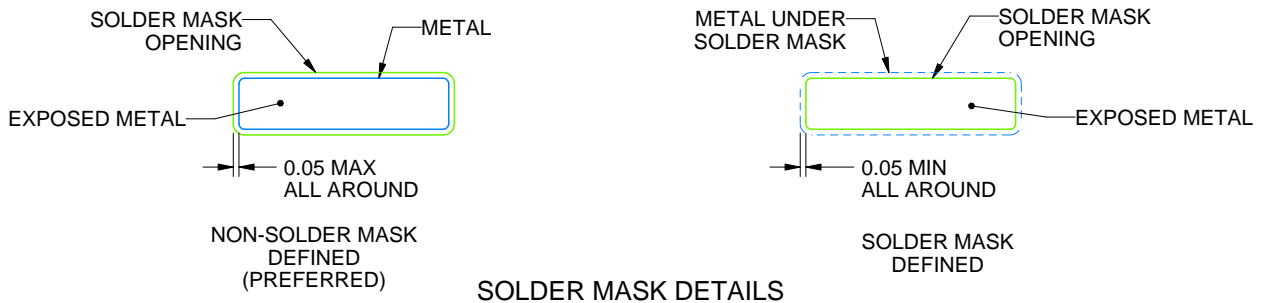

4220763/A 05/2022

NOTES: (continued)

5. Publication IPC-7351 may have alternate designs.
6. Solder mask tolerances between and around signal pads can vary based on board fabrication site.

# EXAMPLE STENCIL DESIGN

DB0016A

SSOP - 2 mm max height

SMALL OUTLINE PACKAGE

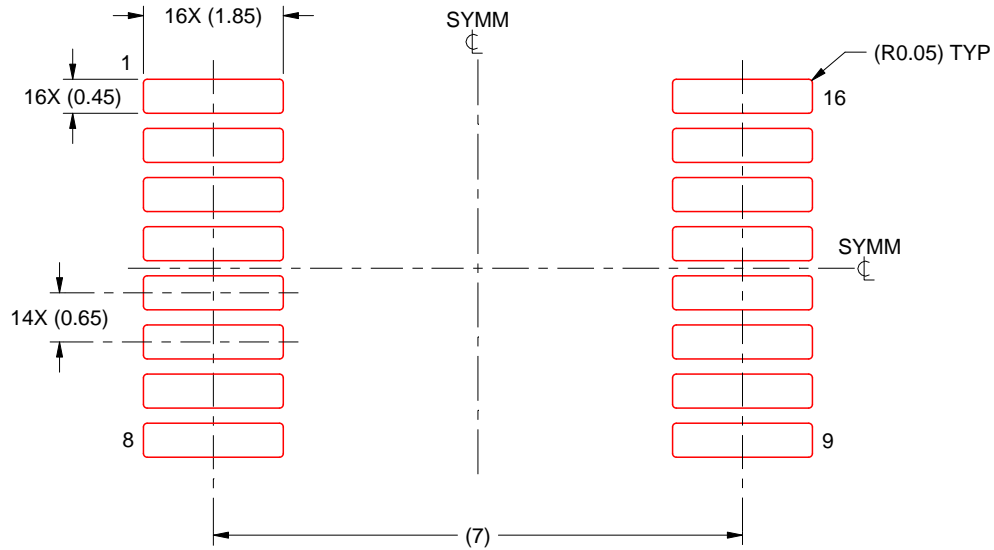

SOLDER PASTE EXAMPLE  
BASED ON 0.125 mm THICK STENCIL  
SCALE: 10X

4220763/A 05/2022

NOTES: (continued)

7. Laser cutting apertures with trapezoidal walls and rounded corners may offer better paste release. IPC-7525 may have alternate design recommendations.
8. Board assembly site may have different recommendations for stencil design.

## IMPORTANT NOTICE AND DISCLAIMER

TI PROVIDES TECHNICAL AND RELIABILITY DATA (INCLUDING DATA SHEETS), DESIGN RESOURCES (INCLUDING REFERENCE DESIGNS), APPLICATION OR OTHER DESIGN ADVICE, WEB TOOLS, SAFETY INFORMATION, AND OTHER RESOURCES "AS IS" AND WITH ALL FAULTS, AND DISCLAIMS ALL WARRANTIES, EXPRESS AND IMPLIED, INCLUDING WITHOUT LIMITATION ANY IMPLIED WARRANTIES OF MERCHANTABILITY, FITNESS FOR A PARTICULAR PURPOSE OR NON-INFRINGEMENT OF THIRD PARTY INTELLECTUAL PROPERTY RIGHTS.

These resources are intended for skilled developers designing with TI products. You are solely responsible for (1) selecting the appropriate TI products for your application, (2) designing, validating and testing your application, and (3) ensuring your application meets applicable standards, and any other safety, security, regulatory or other requirements.

These resources are subject to change without notice. TI grants you permission to use these resources only for development of an application that uses the TI products described in the resource. Other reproduction and display of these resources is prohibited. No license is granted to any other TI intellectual property right or to any third party intellectual property right. TI disclaims responsibility for, and you will fully indemnify TI and its representatives against, any claims, damages, costs, losses, and liabilities arising out of your use of these resources.

TI's products are provided subject to [TI's Terms of Sale](#) or other applicable terms available either on [ti.com](https://www.ti.com) or provided in conjunction with such TI products. TI's provision of these resources does not expand or otherwise alter TI's applicable warranties or warranty disclaimers for TI products.

TI objects to and rejects any additional or different terms you may have proposed.

Mailing Address: Texas Instruments, Post Office Box 655303, Dallas, Texas 75265  
Copyright © 2025, Texas Instruments Incorporated