

## 3-V to 5.5-V Multichannel RS-232 Line Driver and Receiver with $\pm 15$ -kV ESD Protection

### 1 Features

- ESD Protection for RS-232 bus pins
  - $\pm 15$ -kV Human-body model (HBM)
  - $\pm 8$ -kV IEC61000-4-2, Contact discharge
  - $\pm 15$ -kV IEC61000-4-2, Air-gap discharge
- Meets or exceeds the requirements of TIA/EIA-232-F and ITU v.28 standards
- Operates with 3-V to 5.5-V  $V_{CC}$  supply
- Operates up to 500 kbit/s
- Two drivers and two receivers
- Low standby current . . . 1  $\mu$ A Typ
- External capacitors . . .  $4 \times 0.1 \mu$ F
- Accepts 5-V logic input with 3.3-V supply
- Alternative high-speed pin-compatible device (1 Mbit/s) for TRS3222E

### 2 Applications

- Industrial PCs
- Wired networking
- Data center and networking equipment
- Notebooks
- Hand-held equipment

### 3 Description

The TRS3222E consists of two line drivers, two line receivers, and a dual charge-pump circuit with  $\pm 15$ -kV ESD protection pin to pin (serial-port connection pins, including GND).

The device meets the requirements of TIA/EIA-232-F and provides the electrical interface between an asynchronous communication controller and the serial-port connector. The charge pump and four small external capacitors allow operation from a single 3-V to 5.5-V supply. The device operates at typical data signaling rates up to 500 kbit/s and a maximum of 30-V/ $\mu$ s driver output slew rate.

The TRS3222E can be placed in the power-down mode by setting the power-down ( $\overline{\text{PWRDOWN}}$ ) input low, which draws only 1  $\mu$ A from the power supply. When the device is powered down, the receivers remain active while the drivers are placed in the high-impedance state. Also, during power down, the onboard charge pump is disabled;  $V_+$  is lowered to  $V_{CC}$ , and  $V_-$  is raised toward GND. Receiver outputs also can be placed in the high-impedance state by setting enable ( $\overline{\text{EN}}$ ) high.

#### Device Information

PART NUMBER	PACKAGE <sup>(1)</sup>	BODY SIZE (NOM)
TRS3222E	DB (SSOP) (20)	10.2 mm x 5.30 mm
	DW (SOIC) (20)	15.4 mm x 7.50 mm
	PW (TSSOP) (20)	7.80 mm v 4.40 mm

(1) For all available packages, see the orderable addendum at the end of the data sheet.

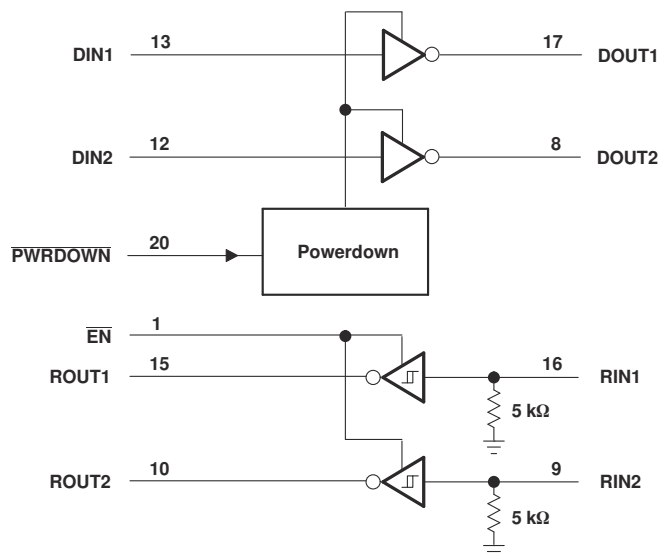

Pin numbers are for the DB, DW, and PW packages.

#### Logic Diagram (Positive Logic)



## Table of Contents

<b>1 Features</b> .....	<b>1</b>	<b>7 Parameter Measurement Information</b> .....	<b>8</b>
<b>2 Applications</b> .....	<b>1</b>	<b>8 Detailed Description</b> .....	<b>10</b>
<b>3 Description</b> .....	<b>1</b>	8.1 Functional Block Diagram.....	10
<b>4 Revision History</b> .....	<b>2</b>	8.2 Device Functional Modes.....	10
<b>5 Pin Configuration and Functions</b> .....	<b>3</b>	<b>9 Application and Implementation</b> .....	<b>11</b>
<b>6 Specifications</b> .....	<b>4</b>	9.1 Application Information.....	11
6.1 Absolute Maximum Ratings.....	4	9.2 Typical Application.....	11
6.2 ESD Ratings.....	4	<b>10 Device and Documentation Support</b> .....	<b>12</b>
6.3 ESD Ratings - IEC Specifications.....	4	10.1 Receiving Notification of Documentation Updates..	12
6.4 Recommended Operating Conditions.....	5	10.2 Support Resources.....	12
6.5 Thermal Information.....	5	10.3 Trademarks.....	12
6.6 Electrical Characteristics.....	5	10.4 Electrostatic Discharge Caution.....	12
6.7 Electrical Characteristics: Driver.....	6	10.5 Glossary.....	12
6.8 Switching Characteristics: Driver.....	6	<b>11 Mechanical, Packaging, and Orderable</b>	
6.9 Electrical Characteristics: Receiver.....	7	<b>Information</b> .....	<b>12</b>
6.10 Switching Characteristics: Receiver.....	7		

## 4 Revision History

NOTE: Page numbers for previous revisions may differ from page numbers in the current version.

<b>Changes from Revision * (June 2007) to Revision A (August 2021)</b>	<b>Page</b>
• Updated the list of <i>Applications</i> .....	1
• Deleted the <i>Ordering Information</i> table.....	1
• Added the <i>Device Information</i> table, the <i>Pin Configuration and Functions</i> , the <i>Detailed Description</i> section, the <i>Application and Implementation</i> section. Removed RHL package from <i>Device Information</i> table and <i>Pin configuration and functions</i> table.....	1
• Deleted the Package thermal impedance from the <i>Absolute Maximum Ratings</i> .....	4
• Added the <i>ESD Ratings</i> table.....	4
• Added the <i>Thermal Information</i> table.....	5
• Changed the value of R <sub>θJA</sub> for PW package (previously in the <i>Absolute Maximum Ratings</i> table), and added additional thermal parameters for all packages in the <i>Thermal Information</i> table.....	5

## 5 Pin Configuration and Functions

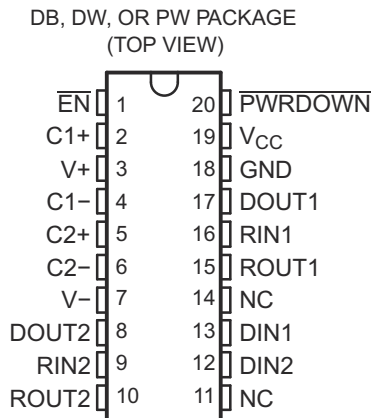

NC – No internal connection

**Table 5-1. Pin Functions**

PIN		I/O	DESCRIPTION
NAME	NO.		
C1+	2	—	Charge pump capacitor pin
C1-	4	—	Charge pump capacitor pin
C2+	5	—	Charge pump capacitor pin
C2-	6	—	Charge pump capacitor pin
DIN1	13	I	Driver logic input
DIN2	12	I	Driver logic input
DOUT1	17	O	RS-232 driver output
DOUT2	8	O	RS-232 driver output
EN	1	I	Receiver enable, active low
GND	18	—	Ground
NC	11,14	—	No internal connection
PWRDOWN	20	I	Driver disable, active low
RIN1	16	I	RS-232 receiver input
RIN2	9	I	RS-232 receiver input
ROUT1	15	O	Receiver logic output
ROUT2	10	O	Receiver logic output
V <sub>CC</sub>	19	—	Power Supply
V+	3	—	Charge pump capacitor pin
V-	7	—	Charge pump capacitor pin

## 6 Specifications

### 6.1 Absolute Maximum Ratings

over operating free-air temperature range (unless otherwise noted) <sup>(1)</sup>

		MIN	MAX	UNIT
V <sub>CC</sub>	Supply voltage range <sup>(2)</sup>	-0.3	6	V
V+	Positive-output supply voltage range <sup>(2)</sup>	-0.3	7	V
V-	Negative-output supply voltage range <sup>(2)</sup>	0.3	-7	V
V+ - V-	Supply voltage difference <sup>(2)</sup>		13	V
V <sub>I</sub>	Input voltage range	Driver ( $\overline{\text{EN}}$ , PWRDOWN)		V
V <sub>O</sub>	Output voltage range	Receiver		V
V <sub>O</sub>	Output voltage range	Driver		V
V <sub>O</sub>	Output voltage range	Receiver		V
T <sub>J</sub>	Operating virtual junction temperature		150	°C
T <sub>stg</sub>	Storage temperature range	-65	150	°C

- (1) Stresses beyond those listed under "absolute maximum ratings" may cause permanent damage to the device. These are stress ratings only, and functional operation of the device at these or any other conditions beyond those indicated under "recommended operating conditions" is not implied. Exposure to absolute-maximum-rated conditions for extended periods may affect device reliability.
- (2) All voltages are with respect to network GND.

### 6.2 ESD Ratings

		VALUE	UNIT	
V <sub>(ESD)</sub>	Electrostatic discharge	Human-body model (HBM), per ANSI/ESDA/JEDEC JS-001 <sup>(1)</sup>	V	
		All pins except RIN1, RIN2, DOUT1 and DOUT2 pins		±3000
		RIN1, RIN2, DOUT1 and DOUT2 pins to GND		±15000
	Charged device model (CDM), per ANSI/ESDA/JEDEC JS-002 <sup>(2)</sup>	All pins	±1500	

- (1) JEDEC document JEP155 states that 500-V HBM allows safe manufacturing with a standard ESD control process.
- (2) JEDEC document JEP157 states that 250-V CDM allows safe manufacturing with a standard ESD control process.

### 6.3 ESD Ratings - IEC Specifications

		VALUE	UNIT
V <sub>(ESD)</sub>	Electrostatic discharge	IEC 61000-4-2 Contact Discharge <sup>(1)</sup>	V
		IEC 61000-4-2 Air-gap Discharge <sup>(1)</sup>	
		RIN1, RIN2, DOUT1 and DOUT2 pins	±15,000

- (1) For PW Package only, a minimum of 1-μF capacitor between V<sub>CC</sub> and GND is required to meet the specified IEC 61000-4-2 rating.

## 6.4 Recommended Operating Conditions

See [Figure 9-1](#) and <sup>(1)</sup>

			MIN	NOM	MAX	UNIT
V <sub>CC</sub>	Supply voltage	V <sub>CC</sub> = 3.3 V	3	3.3	3.6	V
		V <sub>CC</sub> = 5 V	4.5	5	5.5	
V <sub>IH</sub>	Driver and control high-level input voltage	DIN, $\overline{\text{EN}}$ , PWRDOWN	V <sub>CC</sub> = 3.3 V	2		V
			V <sub>CC</sub> = 5 V	2.4		
V <sub>IL</sub>	Driver and control low-level input voltage	DIN, $\overline{\text{EN}}$ , PWRDOWN			0.8	V
V <sub>I</sub>	Driver and control input voltage	DIN, $\overline{\text{EN}}$ , PWRDOWN	0		5.5	V
V <sub>I</sub>	Receiver input voltage		-25		25	V
T <sub>A</sub>	Operating free-air temperature	TRS3222EC	0		70	°C
		TRS3222EI	-40		85	

(1) Test conditions are C1–C4 = 0.1 μF at V<sub>CC</sub> = 3.3 V ± 0.3 V; C1 = 0.047 μF, C2–C4 = 0.33 μF at V<sub>CC</sub> = 5 V ± 0.5 V.

## 6.5 Thermal Information

THERMAL METRIC <sup>(1)</sup>		TRS3222E			UNIT
		DB (SSOP)	DW (SOIC)	PW (TSSOP)	
		20 Pins	20 Pins	20 Pins	
R <sub>θJA</sub>	Junction-to-ambient thermal resistance	70	58	94.1	°C/W
R <sub>θJC(top)</sub>	Junction-to-case (top) thermal resistance	33.6	30.0	35.2	°C/W
R <sub>θJB</sub>	Junction-to-board thermal resistance	36.4	29.6	45.5	°C/W
ψ <sub>JT</sub>	Junction-to-top characterization parameter	4.8	7.7	3.1	°C/W
ψ <sub>JB</sub>	Junction-to-board characterization parameter	35.9	29.3	45.1	°C/W

(1) For more information about traditional and new thermal metrics, see the [Semiconductor and IC package thermal metrics](#) application report.

## 6.6 Electrical Characteristics

over recommended ranges of supply voltage and operating free-air temperature (unless otherwise noted) (see [Figure 9-1](#))

PARAMETER		TEST CONDITIONS <sup>(2)</sup>	MIN	TYP <sup>(1)</sup>	MAX	UNIT
I <sub>I</sub>	Input leakage current ( $\overline{\text{EN}}$ , PWRDOWN)			±0.01	±1	μA
I <sub>CC</sub>	Supply current	No load, PWRDOWN at V <sub>CC</sub>		0.3	1	mA
	Supply current (powered off)	No load, PWRDOWN at GND		1	10	μA

(1) All typical values are at V<sub>CC</sub> = 3.3 V or V<sub>CC</sub> = 5 V, and T<sub>A</sub> = 25°C.

(2) Test conditions are C1–C4 = 0.1 μF at V<sub>CC</sub> = 3.3 V ± 0.3 V; C1 = 0.047 μF, C2–C4 = 0.33 μF at V<sub>CC</sub> = 5 V ± 0.5 V.

## 6.7 Electrical Characteristics: Driver

over recommended ranges of supply voltage and operating free-air temperature (unless otherwise noted) (see [Figure 9-1](#))

PARAMETER		TEST CONDITIONS <sup>(3)</sup>		MIN	TYP <sup>(1)</sup>	MAX	UNIT
V <sub>OH</sub>	High-level output voltage	DOUT at R <sub>L</sub> = 3 kΩ to GND, DIN = GND		5	5.4		V
V <sub>OL</sub>	Low-level output voltage	DOUT at R <sub>L</sub> = 3 kΩ to GND, DIN = V <sub>CC</sub>		-5	-5.4		V
I <sub>IH</sub>	High-level input current	V <sub>I</sub> = V <sub>CC</sub>			±0.01	±1	μA
I <sub>IL</sub>	Low-level input current	V <sub>I</sub> at GND			±0.01	±1	μA
I <sub>OS</sub>	Short-circuit output current <sup>(2)</sup>	V <sub>CC</sub> = 3.6 V	V <sub>O</sub> = 0 V		±35	±60	mA
		V <sub>CC</sub> = 5.5 V					
r <sub>o</sub>	Output resistance	V <sub>CC</sub> , V+, and V- = 0 V, V <sub>O</sub> = ±2 V		300	10M		Ω
I <sub>OZ</sub>	Output leakage current	PWRDOWN = GND	V <sub>CC</sub> = 3 V to 3.6 V, V <sub>O</sub> = ±12 V			±25	μA
				V <sub>CC</sub> = 4.5 V to 5.5 V, V <sub>O</sub> = ±10 V			

(1) All typical values are at V<sub>CC</sub> = 3.3 V or V<sub>CC</sub> = 5 V, and T<sub>A</sub> = 25°C.

(2) Short-circuit durations should be controlled to prevent exceeding the device absolute power dissipation ratings, and not more than one output should be shorted at a time.

(3) Test conditions are C1–C4 = 0.1 μF at V<sub>CC</sub> = 3.3 V ± 0.3 V; C1 = 0.047 μF, C2–C4 = 0.33 μF at V<sub>CC</sub> = 5 V ± 0.5 V.

## 6.8 Switching Characteristics: Driver

over recommended ranges of supply voltage and operating free-air temperature (unless otherwise noted) (see [Figure 9-1](#))

PARAMETER		TEST CONDITIONS <sup>(3)</sup>		MIN	TYP <sup>(1)</sup>	MAX	UNIT
	Maximum data rate	C <sub>L</sub> = 1000 pF, One DOUT switching,	R <sub>L</sub> = 3 kΩ, See <a href="#">Figure 7-1</a>	250	500		kbit/s
t <sub>sk(p)</sub>	Pulse skew <sup>(2)</sup>	C <sub>L</sub> = 150 pF to 2500 pF, See <a href="#">Figure 7-2</a>	R <sub>L</sub> = 3 kΩ to 7 kΩ,		300		ns
SR(tr)	Slew rate, transition region (see <a href="#">Figure 7-1</a> )	R <sub>L</sub> = 3 kΩ to 7 kΩ, V <sub>CC</sub> = 3.3 V	C <sub>L</sub> = 150 pF to 1000 pF	6		30	V/μs
			C <sub>L</sub> = 150 pF to 2500 pF	4		30	

(1) All typical values are at V<sub>CC</sub> = 3.3 V or V<sub>CC</sub> = 5 V, and T<sub>A</sub> = 25°C.

(2) Pulse skew is defined as |t<sub>PLH</sub> - t<sub>PHL</sub>| of each channel of the same device.

(3) Test conditions are C1–C4 = 0.1 μF at V<sub>CC</sub> = 3.3 V ± 0.3 V; C1 = 0.047 μF, C2–C4 = 0.33 μF at V<sub>CC</sub> = 5 V ± 0.5 V.

## 6.9 Electrical Characteristics: Receiver

over recommended ranges of supply voltage and operating free-air temperature (unless otherwise noted) (see [Figure 9-1](#))

PARAMETER		TEST CONDITIONS <sup>(2)</sup>	MIN	TYP <sup>(1)</sup>	MAX	UNIT
V <sub>OH</sub>	High-level output voltage	I <sub>OH</sub> = -1 mA	V <sub>CC</sub> - 0.6	V <sub>CC</sub> - 0.1		V
V <sub>OL</sub>	Low-level output voltage	I <sub>OL</sub> = 1.6 mA			0.4	V
V <sub>IT+</sub>	Positive-going input threshold voltage	V <sub>CC</sub> = 3.3 V		1.5	2.4	V
		V <sub>CC</sub> = 5 V		1.8	2.4	
V <sub>IT-</sub>	Negative-going input threshold voltage	V <sub>CC</sub> = 3.3 V	0.6	1.2		V
		V <sub>CC</sub> = 5 V	0.8	1.5		
V <sub>hys</sub>	Input hysteresis (V <sub>IT+</sub> - V <sub>IT-</sub> )			0.3		V
I <sub>OZ</sub>	Output leakage current	EN = 1		±0.05	±10	µA
r <sub>I</sub>	Input resistance	V <sub>I</sub> = ±3 V to ±25 V	3	5	7	kΩ

(1) All typical values are at V<sub>CC</sub> = 3.3 V or V<sub>CC</sub> = 5 V, and T<sub>A</sub> = 25°C.

(2) Test conditions are C1–C4 = 0.1 µF at V<sub>CC</sub> = 3.3 V ± 0.3 V; C1 = 0.047 µF, C2–C4 = 0.33 µF at V<sub>CC</sub> = 5 V ± 0.5 V.

## 6.10 Switching Characteristics: Receiver

over recommended ranges of supply voltage and operating free-air temperature (unless otherwise noted)

PARAMETER		TEST CONDITIONS <sup>(3)</sup>	TYP <sup>(1)</sup>	UNIT
t <sub>PLH</sub>	Propagation delay time, low- to high-level output	C <sub>L</sub> = 150 pF, See <a href="#">Figure 7-3</a>	300	ns
t <sub>PHL</sub>	Propagation delay time, high- to low-level output	C <sub>L</sub> = 150 pF, See <a href="#">Figure 7-3</a>	300	ns
t <sub>en</sub>	Output enable time	C <sub>L</sub> = 150 pF, R <sub>L</sub> = 3 kΩ, See <a href="#">Figure 7-4</a>	200	ns
t <sub>dis</sub>	Output disable time	C <sub>L</sub> = 150 pF, R <sub>L</sub> = 3 kΩ, See <a href="#">Figure 7-4</a>	200	ns
t <sub>sk(p)</sub>	Pulse skew <sup>(2)</sup>	See <a href="#">Figure 7-3</a>	300	ns

(1) All typical values are at V<sub>CC</sub> = 3.3 V or V<sub>CC</sub> = 5 V, and T<sub>A</sub> = 25°C.

(2) Pulse skew is defined as |t<sub>PLH</sub> - t<sub>PHL</sub>| of each channel of the same device.

(3) Test conditions are C1–C4 = 0.1 µF at V<sub>CC</sub> = 3.3 V ± 0.3 V; C1 = 0.047 µF, C2–C4 = 0.33 µF at V<sub>CC</sub> = 5 V ± 0.5 V.

## 7 Parameter Measurement Information

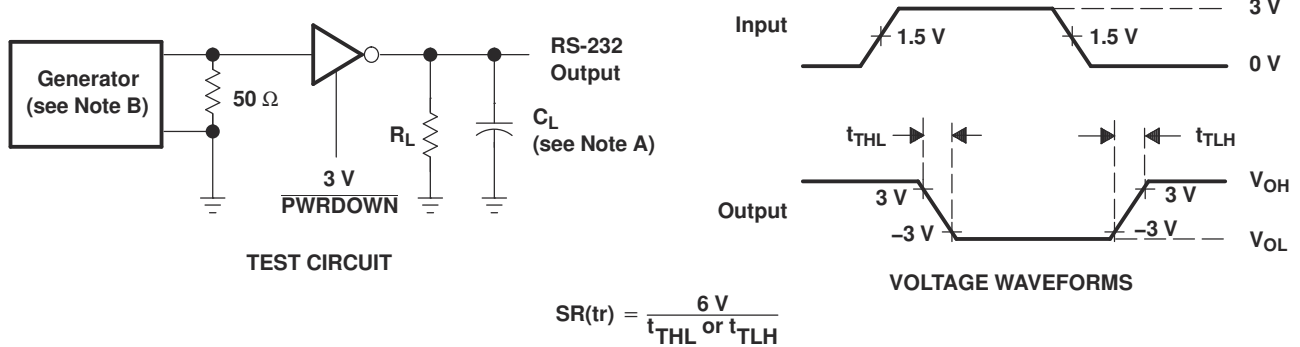

- A.  $C_L$  includes probe and jig capacitance.
- B. The pulse generator has the following characteristics: PRR = 250 kbit/s,  $Z_0 = 50\ \Omega$ , 50% duty cycle,  $t_r \leq 10\text{ ns}$ ,  $t_f \leq 10\text{ ns}$ .

**Figure 7-1. Driver Slew Rate**

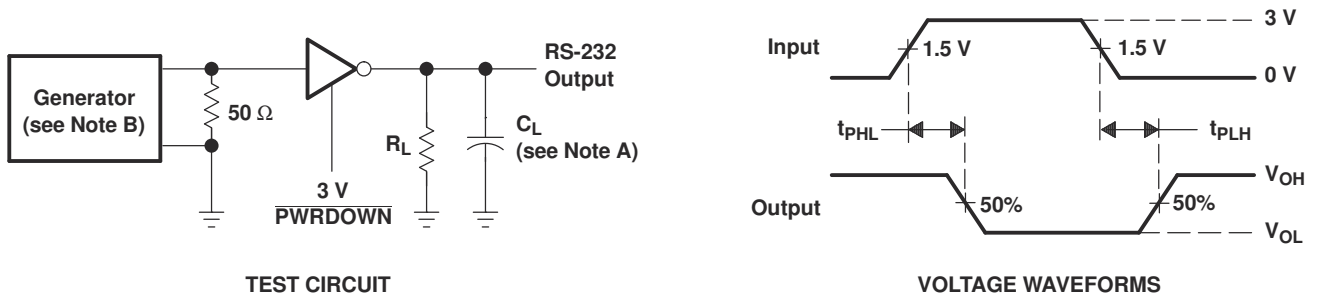

- A.  $C_L$  includes probe and jig capacitance.
- B. The pulse generator has the following characteristics: PRR = 250 kbit/s,  $Z_0 = 50\ \Omega$ , 50% duty cycle,  $t_r \leq 10\text{ ns}$ ,  $t_f \leq 10\text{ ns}$ .

**Figure 7-2. Driver Pulse Skew**

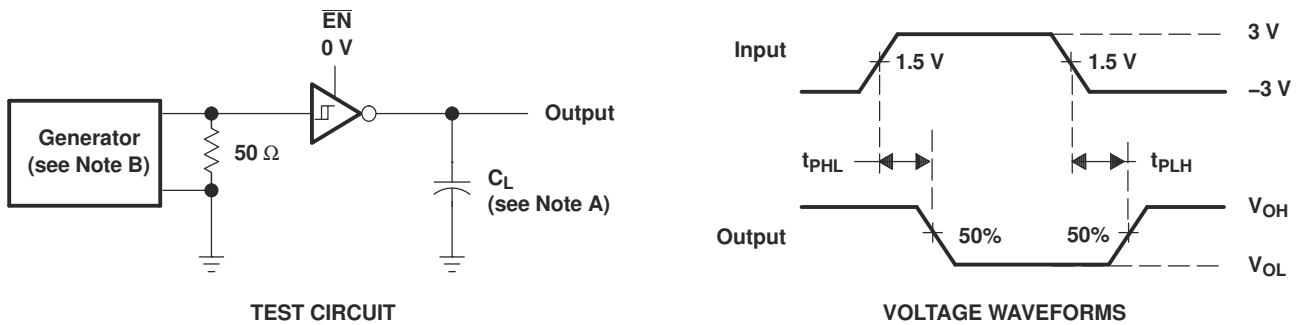

- A.  $C_L$  includes probe and jig capacitance.
- B. The pulse generator has the following characteristics:  $Z_0 = 50\ \Omega$ , 50% duty cycle,  $t_r \leq 10\text{ ns}$ ,  $t_f \leq 10\text{ ns}$ .

**Figure 7-3. Receiver Propagation Delay Times**

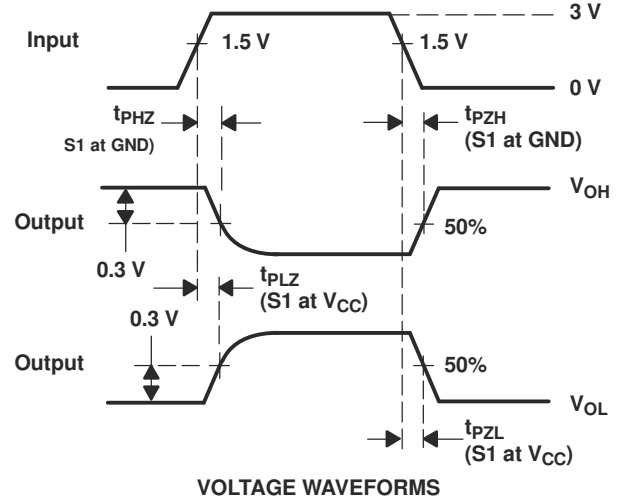
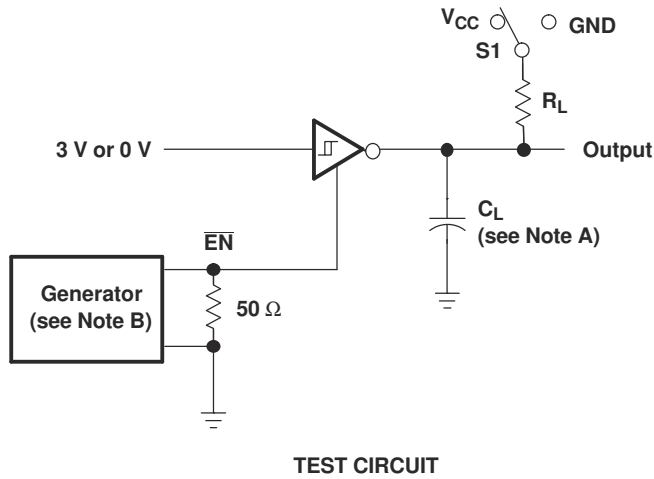

- A.  $C_L$  includes probe and jig capacitance.
- B. The pulse generator has the following characteristics:  $Z_O = 50\ \Omega$ , 50% duty cycle,  $t_r \leq 10\ ns$ ,  $t_f \leq 10\ ns$ .

**Figure 7-4. Receiver Enable and Disable Times**

## 8 Detailed Description

### 8.1 Functional Block Diagram

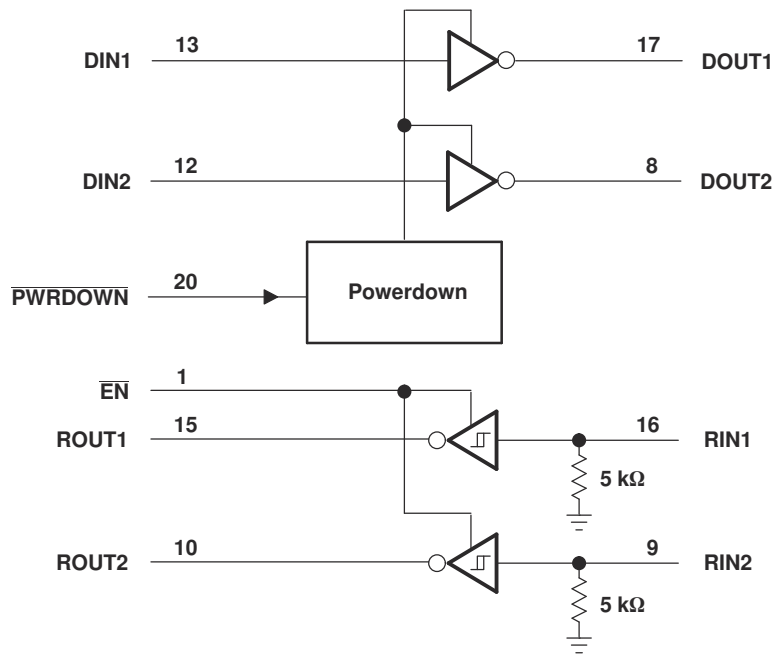

Pin numbers are for the DB, DW, and PW packages.

Figure 8-1. Logic Diagram (Positive Logic)

### 8.2 Device Functional Modes

Table 8-1. Function Table: Each Driver

INPUTS <sup>(1)</sup>		OUTPUT DOUT
DIN	PWRDOWN	
X	L	Z
L	H	H
H	H	L

(1) H = high level, L = low level, X = irrelevant, Z = high impedance

Table 8-2. Function Table: Each Receiver

INPUTS <sup>(1)</sup>		OUTPUT ROUT
RIN	EN	
L	L	H
H	L	L
X	H	Z
Open	L	H

(1) H = high level, L = low level, X = irrelevant,  
Z = high impedance (off),  
Open = input disconnected or connected driver off

## 9 Application and Implementation

### Note

Information in the following applications sections is not part of the TI component specification, and TI does not warrant its accuracy or completeness. TI's customers are responsible for determining suitability of components for their purposes, as well as validating and testing their design implementation to confirm system functionality.

### 9.1 Application Information

### 9.2 Typical Application

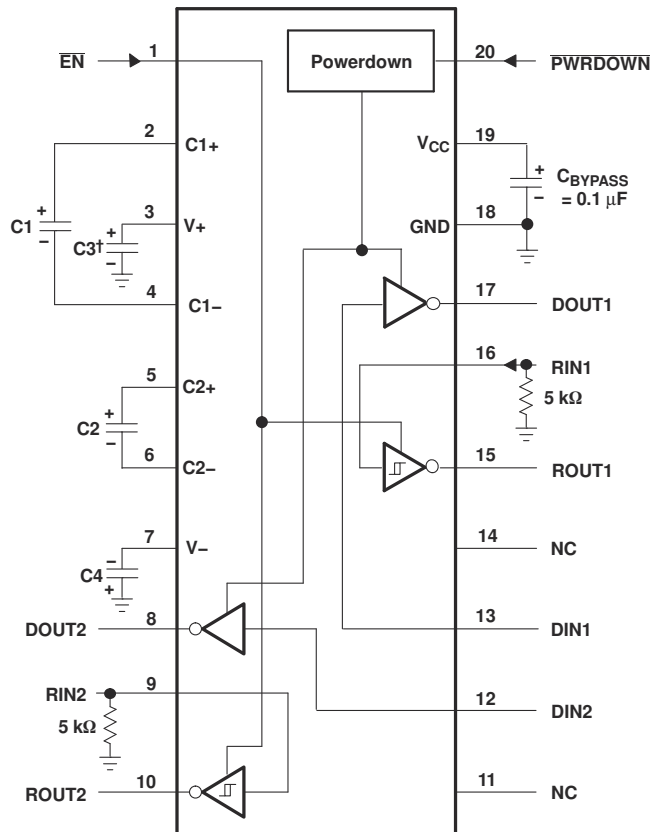

† C3 can be connected to V<sub>CC</sub> or GND.

NOTES: A. Resistor values shown are nominal.

B. NC – No internal connection

C. Nonpolarized ceramic capacitors are acceptable. If polarized tantalum or electrolytic capacitors are used, they should be connected as shown.

V<sub>CC</sub> vs CAPACITOR VALUES

V <sub>CC</sub>	C1	C2, C3, and C4
3.3 V ± 0.3 V	0.1 μF	0.1 μF
5 V ± 0.5 V	0.047 μF	0.33 μF
3 V to 5.5 V	0.1 μF	0.47 μF

Figure 9-1. Typical Operating Circuit and Capacitor Values

## 10 Device and Documentation Support

TI offers an extensive line of development tools. Tools and software to evaluate the performance of the device, generate code, and develop solutions are listed below.

### 10.1 Receiving Notification of Documentation Updates

To receive notification of documentation updates, navigate to the device product folder on [ti.com](http://ti.com). Click on *Subscribe to updates* to register and receive a weekly digest of any product information that has changed. For change details, review the revision history included in any revised document.

### 10.2 Support Resources

TI E2E™ [support forums](#) are an engineer's go-to source for fast, verified answers and design help — straight from the experts. Search existing answers or ask your own question to get the quick design help you need.

Linked content is provided "AS IS" by the respective contributors. They do not constitute TI specifications and do not necessarily reflect TI's views; see TI's [Terms of Use](#).

### 10.3 Trademarks

TI E2E™ is a trademark of Texas Instruments.

All trademarks are the property of their respective owners.

### 10.4 Electrostatic Discharge Caution



This integrated circuit can be damaged by ESD. Texas Instruments recommends that all integrated circuits be handled with appropriate precautions. Failure to observe proper handling and installation procedures can cause damage.

ESD damage can range from subtle performance degradation to complete device failure. Precision integrated circuits may be more susceptible to damage because very small parametric changes could cause the device not to meet its published specifications.

### 10.5 Glossary

[TI Glossary](#) This glossary lists and explains terms, acronyms, and definitions.

## 11 Mechanical, Packaging, and Orderable Information

The following pages include mechanical, packaging, and orderable information. This information is the most current data available for the designated devices. This data is subject to change without notice and revision of this document. For browser-based versions of this data sheet, refer to the left-hand navigation.

**PACKAGING INFORMATION**

Orderable part number	Status (1)	Material type (2)	Package   Pins	Package qty   Carrier	RoHS (3)	Lead finish/ Ball material (4)	MSL rating/ Peak reflow (5)	Op temp (°C)	Part marking (6)
<a href="#">TRS3222ECDB</a>	Obsolete	Production	SSOP (DB)   20	-	-	Call TI	Call TI	0 to 70	RS22EC
<a href="#">TRS3222ECDBR</a>	Obsolete	Production	SSOP (DB)   20	-	-	Call TI	Call TI	0 to 70	RS22EC
<a href="#">TRS3222ECDW</a>	Obsolete	Production	SOIC (DW)   20	-	-	Call TI	Call TI	0 to 70	TRS3222EC
<a href="#">TRS3222ECPW</a>	Obsolete	Production	TSSOP (PW)   20	-	-	Call TI	Call TI	0 to 70	RS22EC
<a href="#">TRS3222EIDBR</a>	Obsolete	Production	SSOP (DB)   20	-	-	Call TI	Call TI	-40 to 85	RS22EI
<a href="#">TRS3222EIPWR</a>	Active	Production	TSSOP (PW)   20	2000   LARGE T&R	Yes	NIPDAU   NIPDAU	Level-1-260C-UNLIM	-40 to 85	RS22EI
TRS3222EIPWR.A	Active	Production	TSSOP (PW)   20	2000   LARGE T&R	Yes	NIPDAU	Level-1-260C-UNLIM	-40 to 85	RS22EI
TRS3222EIPWRG4	Active	Production	TSSOP (PW)   20	2000   LARGE T&R	Yes	NIPDAU   NIPDAU	Level-1-260C-UNLIM	-40 to 85	RS22EI
TRS3222EIPWRG4.A	Active	Production	TSSOP (PW)   20	2000   LARGE T&R	Yes	NIPDAU	Level-1-260C-UNLIM	-40 to 85	RS22EI

(1) **Status:** For more details on status, see our [product life cycle](#).

(2) **Material type:** When designated, preproduction parts are prototypes/experimental devices, and are not yet approved or released for full production. Testing and final process, including without limitation quality assurance, reliability performance testing, and/or process qualification, may not yet be complete, and this item is subject to further changes or possible discontinuation. If available for ordering, purchases will be subject to an additional waiver at checkout, and are intended for early internal evaluation purposes only. These items are sold without warranties of any kind.

(3) **RoHS values:** Yes, No, RoHS Exempt. See the [TI RoHS Statement](#) for additional information and value definition.

(4) **Lead finish/Ball material:** Parts may have multiple material finish options. Finish options are separated by a vertical ruled line. Lead finish/Ball material values may wrap to two lines if the finish value exceeds the maximum column width.

(5) **MSL rating/Peak reflow:** The moisture sensitivity level ratings and peak solder (reflow) temperatures. In the event that a part has multiple moisture sensitivity ratings, only the lowest level per JEDEC standards is shown. Refer to the shipping label for the actual reflow temperature that will be used to mount the part to the printed circuit board.

(6) **Part marking:** There may be an additional marking, which relates to the logo, the lot trace code information, or the environmental category of the part.

Multiple part markings will be inside parentheses. Only one part marking contained in parentheses and separated by a "-" will appear on a part. If a line is indented then it is a continuation of the previous line and the two combined represent the entire part marking for that device.

**Important Information and Disclaimer:** The information provided on this page represents TI's knowledge and belief as of the date that it is provided. TI bases its knowledge and belief on information provided by third parties, and makes no representation or warranty as to the accuracy of such information. Efforts are underway to better integrate information from third parties. TI has taken and continues to take reasonable steps to provide representative

and accurate information but may not have conducted destructive testing or chemical analysis on incoming materials and chemicals. TI and TI suppliers consider certain information to be proprietary, and thus CAS numbers and other limited information may not be available for release.

In no event shall TI's liability arising out of such information exceed the total purchase price of the TI part(s) at issue in this document sold by TI to Customer on an annual basis.

**TAPE AND REEL INFORMATION**

**QUADRANT ASSIGNMENTS FOR PIN 1 ORIENTATION IN TAPE**

\*All dimensions are nominal

Device	Package Type	Package Drawing	Pins	SPQ	Reel Diameter (mm)	Reel Width W1 (mm)	A0 (mm)	B0 (mm)	K0 (mm)	P1 (mm)	W (mm)	Pin1 Quadrant
TRS3222EIPWR	TSSOP	PW	20	2000	330.0	16.4	6.95	7.0	1.4	8.0	16.0	Q1
TRS3222EIPWR	TSSOP	PW	20	2000	330.0	16.4	6.95	7.0	1.4	8.0	16.0	Q1
TRS3222EIPWRG4	TSSOP	PW	20	2000	330.0	16.4	6.95	7.0	1.4	8.0	16.0	Q1

**TAPE AND REEL BOX DIMENSIONS**

\*All dimensions are nominal

Device	Package Type	Package Drawing	Pins	SPQ	Length (mm)	Width (mm)	Height (mm)
TRS3222EIPWR	TSSOP	PW	20	2000	356.0	356.0	35.0
TRS3222EIPWR	TSSOP	PW	20	2000	356.0	356.0	35.0
TRS3222EIPWRG4	TSSOP	PW	20	2000	356.0	356.0	35.0

# DB0020A



# PACKAGE OUTLINE

## SSOP - 2 mm max height

SMALL OUTLINE PACKAGE



4214851/B 08/2019

### NOTES:

1. All linear dimensions are in millimeters. Any dimensions in parenthesis are for reference only. Dimensioning and tolerancing per ASME Y14.5M.
2. This drawing is subject to change without notice.
3. This dimension does not include mold flash, protrusions, or gate burrs. Mold flash, protrusions, or gate burrs shall not exceed 0.15 mm per side.
4. This dimension does not include interlead flash. Interlead flash shall not exceed 0.25 mm per side.
5. Reference JEDEC registration MO-150.

# EXAMPLE BOARD LAYOUT

DB0020A

SSOP - 2 mm max height

SMALL OUTLINE PACKAGE



LAND PATTERN EXAMPLE  
EXPOSED METAL SHOWN  
SCALE: 10X



4214851/B 08/2019

NOTES: (continued)

- 6. Publication IPC-7351 may have alternate designs.
- 7. Solder mask tolerances between and around signal pads can vary based on board fabrication site.

# EXAMPLE STENCIL DESIGN

DB0020A

SSOP - 2 mm max height

SMALL OUTLINE PACKAGE



SOLDER PASTE EXAMPLE  
BASED ON 0.125 mm THICK STENCIL  
SCALE: 10X

4214851/B 08/2019

NOTES: (continued)

8. Laser cutting apertures with trapezoidal walls and rounded corners may offer better paste release. IPC-7525 may have alternate design recommendations.
9. Board assembly site may have different recommendations for stencil design.

# DW0020A



# PACKAGE OUTLINE

## SOIC - 2.65 mm max height

SOIC



4220724/A 05/2016

**NOTES:**

1. All linear dimensions are in millimeters. Dimensions in parenthesis are for reference only. Dimensioning and tolerancing per ASME Y14.5M.
2. This drawing is subject to change without notice.
3. This dimension does not include mold flash, protrusions, or gate burrs. Mold flash, protrusions, or gate burrs shall not exceed 0.15 mm per side.
4. This dimension does not include interlead flash. Interlead flash shall not exceed 0.43 mm per side.
5. Reference JEDEC registration MS-013.

# EXAMPLE BOARD LAYOUT

DW0020A

SOIC - 2.65 mm max height

SOIC



LAND PATTERN EXAMPLE  
SCALE:6X



SOLDER MASK DETAILS

4220724/A 05/2016

NOTES: (continued)

- 6. Publication IPC-7351 may have alternate designs.
- 7. Solder mask tolerances between and around signal pads can vary based on board fabrication site.

# EXAMPLE STENCIL DESIGN

DW0020A

SOIC - 2.65 mm max height

SOIC



SOLDER PASTE EXAMPLE  
BASED ON 0.125 mm THICK STENCIL  
SCALE:6X

4220724/A 05/2016

NOTES: (continued)

8. Laser cutting apertures with trapezoidal walls and rounded corners may offer better paste release. IPC-7525 may have alternate design recommendations.
9. Board assembly site may have different recommendations for stencil design.

# PW0020A



# PACKAGE OUTLINE

## TSSOP - 1.2 mm max height

SMALL OUTLINE PACKAGE



4220206/A 02/2017

### NOTES:

1. All linear dimensions are in millimeters. Any dimensions in parenthesis are for reference only. Dimensioning and tolerancing per ASME Y14.5M.
2. This drawing is subject to change without notice.
3. This dimension does not include mold flash, protrusions, or gate burrs. Mold flash, protrusions, or gate burrs shall not exceed 0.15 mm per side.
4. This dimension does not include interlead flash. Interlead flash shall not exceed 0.25 mm per side.
5. Reference JEDEC registration MO-153.

# EXAMPLE BOARD LAYOUT

PW0020A

TSSOP - 1.2 mm max height

SMALL OUTLINE PACKAGE



LAND PATTERN EXAMPLE  
EXPOSED METAL SHOWN  
SCALE: 10X



SOLDER MASK DETAILS

4220206/A 02/2017

NOTES: (continued)

- 6. Publication IPC-7351 may have alternate designs.
- 7. Solder mask tolerances between and around signal pads can vary based on board fabrication site.

# EXAMPLE STENCIL DESIGN

PW0020A

TSSOP - 1.2 mm max height

SMALL OUTLINE PACKAGE



SOLDER PASTE EXAMPLE  
BASED ON 0.125 mm THICK STENCIL  
SCALE: 10X

4220206/A 02/2017

NOTES: (continued)

8. Laser cutting apertures with trapezoidal walls and rounded corners may offer better paste release. IPC-7525 may have alternate design recommendations.
9. Board assembly site may have different recommendations for stencil design.

## IMPORTANT NOTICE AND DISCLAIMER

TI PROVIDES TECHNICAL AND RELIABILITY DATA (INCLUDING DATA SHEETS), DESIGN RESOURCES (INCLUDING REFERENCE DESIGNS), APPLICATION OR OTHER DESIGN ADVICE, WEB TOOLS, SAFETY INFORMATION, AND OTHER RESOURCES "AS IS" AND WITH ALL FAULTS, AND DISCLAIMS ALL WARRANTIES, EXPRESS AND IMPLIED, INCLUDING WITHOUT LIMITATION ANY IMPLIED WARRANTIES OF MERCHANTABILITY, FITNESS FOR A PARTICULAR PURPOSE OR NON-INFRINGEMENT OF THIRD PARTY INTELLECTUAL PROPERTY RIGHTS.

These resources are intended for skilled developers designing with TI products. You are solely responsible for (1) selecting the appropriate TI products for your application, (2) designing, validating and testing your application, and (3) ensuring your application meets applicable standards, and any other safety, security, regulatory or other requirements.

These resources are subject to change without notice. TI grants you permission to use these resources only for development of an application that uses the TI products described in the resource. Other reproduction and display of these resources is prohibited. No license is granted to any other TI intellectual property right or to any third party intellectual property right. TI disclaims responsibility for, and you will fully indemnify TI and its representatives against, any claims, damages, costs, losses, and liabilities arising out of your use of these resources.

TI's products are provided subject to [TI's Terms of Sale](#) or other applicable terms available either on [ti.com](https://www.ti.com) or provided in conjunction with such TI products. TI's provision of these resources does not expand or otherwise alter TI's applicable warranties or warranty disclaimers for TI products.

TI objects to and rejects any additional or different terms you may have proposed.

Mailing Address: Texas Instruments, Post Office Box 655303, Dallas, Texas 75265

Copyright © 2025, Texas Instruments Incorporated