

TMAG5133 Low-Power, In-plane High Sensitivity Hall-Effect Switch

1 Features

- Supply range: 1.65V to 5.5V
- Operating temperature range: -40°C to 125°C
- In-plane axis of sensitivity
- Magnetic pole detection:
 - Dual unipolar
 - Omnipolar (preview)
- Output type:
 - Push-pull
 - Open-drain (preview)
- Magnetic operate point (B_{OP}):
 - $\pm 3\text{mT}$
 - 1.8mT to 15mT options
- Magnetic hysteresis ($B_{OP} - B_{RP}$): $\pm 0.8\text{mT}$
- Duty cycle operation
 - 20Hz: $1.8\mu\text{A}$
 - 1.25Hz to 8kHz options
- Industry standard package and pinout
 - 4-pin X1LGA
 - SOT-23 (preview)

2 Applications

- [Door and window sensors](#)
- [Refrigerator and freeze door open/close sensors](#)
- [Electricity meter tamper detection](#)
- [Electronic smart locks](#)
- [Smoke detector push buttons](#)
- [PC and notebooks](#)
- [Tablets](#)
- [Water meters](#)
- [Gas meters](#)

3 Description

The TMAG5133 is an in-plane Hall-effect switch designed to replace TMR, AMR and Reed switches. The device is optimized to enable small form factors across industrial and consumer applications with ultra-low power consumption, wide supply and temperature ranges.

The TMAG5133 has two unipolar outputs or a single omnipolar which enable the device to react to external magnetic fields. When the applied magnetic flux density through the sensor axis of sensitivity exceeds the operate point threshold (B_{OP}), the device outputs a low voltage on the respective pin. The output stays low until the magnetic flux density decreases to less than the release point threshold (B_{RP}), after which the device outputs a high voltage.

To minimize power consumption, the TMAG5133 is internally duty-cycled. The device has a push-pull output which eliminates the need for an external pullup resistor, and is available in an industry standard X1LGA package.

Package Information

PART NUMBER	PACKAGE ⁽¹⁾	PACKAGE SIZE ⁽²⁾
TMAG5133	ZFC (X1LGA, 4)	1.3mm × 0.9mm
	DBV (SOT-23, 3) ⁽³⁾	2.9mm × 2.8mm

- (1) For all available packages, see [Section 10](#).
- (2) The package size (length × width) is a nominal value and includes pins, where applicable.
- (3) This package is preview only.

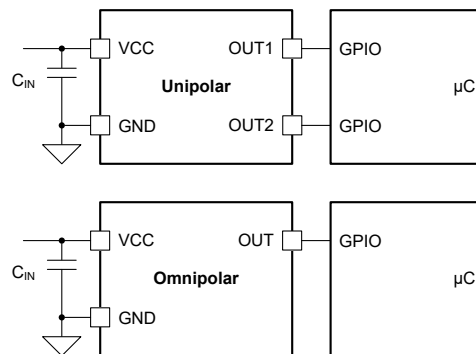

Simplified Schematic



Table of Contents

1 Features	1	7 Detailed Description	7
2 Applications	1	7.1 Overview.....	7
3 Description	1	7.2 Functional Block Diagram.....	7
4 Device Comparison	3	7.3 Feature Description.....	7
5 Pin Configuration and Functions	3	7.4 Device Functional Modes.....	10
6 Specifications	4	8 Application and Implementation	11
6.1 Absolute Maximum Ratings.....	4	8.1 Application Information.....	11
6.2 ESD Ratings.....	4	8.2 Typical Application.....	11
6.3 Recommended Operating Conditions.....	4	8.3 Power Supply Recommendations.....	12
6.4 Thermal Information.....	4	8.4 Layout.....	12
6.5 Electrical Characteristics.....	5	9 Revision History	12
6.6 Magnetic Characteristics.....	6	10 Mechanical, Packaging, and Orderable Information	12
6.7 Typical Characteristics.....	6		

4 Device Comparison

Table 4-1. Released Device Comparison

VERSION	TYPICAL THRESHOLD	TYPICAL HYSTERESIS	MAGNETIC RESPONSE	OUTPUT TYPE	SENSOR ORIENTATION	SAMPLING RATE	PACKAGES AVAILABLE
TMAG5133D5D	3mT	0.8mT	Unipolar, active low	Push-pull	In-plane	20Hz	X1LGA

Table 4-2 indicates the B_{OP} , output configuration, and sampling rate options available for the TMAG5133xxx. E.g. TMAG5133C6G is a 2.5mT BOP, Unipolar, Active High, Open Drain, 160Hz version of the device.

Table 4-2. Additional device configuration options

B_{OP}	Output Configuration				Sampling Rate
	Option Number	Omnipolar or Unipolar	Active Low or Active High	Open Drain or Push-pull	
A = 1.8mT	0 - Omni, L, OD	0 - Omnipolar	0 - Active Low	0 - Open Drain	A = 1.25Hz
B = 2.0mT	1 - Omni, L, P-p	0 - Omnipolar	0 - Active Low	1 - Push-pull	B = 5Hz
C = 2.5mT	2 - Omni, H, OD	0 - Omnipolar	1 - Active High	0 - Open Drain	C = 10Hz
D = 3.0mT	3 - Omni, H, P-p	0 - Omnipolar	1 - Active High	1 - Push-pull	D = 20Hz
E = 6mT	4 - Uni, L, OD	1 - Unipolar	0 - Active Low	0 - Open Drain	E = 40Hz
F = 12mT	5 - Uni, L, P-p	1 - Unipolar	0 - Active Low	1 - Push-pull	F = 80Hz
G = 15mT	6 - Uni, H, OD	1 - Unipolar	1 - Active High	0 - Open Drain	G = 1600Hz
	7 - Uni, H, P-p	1 - Unipolar	1 - Active High	1 - Push-pull	H = 320Hz
					I = 640Hz
					J = 8kHz
					K = 2.5kHz

5 Pin Configuration and Functions



Figure 5-1. ZFC Package 4-Pin X1LGA Top View

Table 5-1. Pin Functions

PIN		TYPE	DESCRIPTION
NAME	X1LGA (4)		
OUT2	1	O	Unipolar output, responds to negative magnetic flux density through the package.
GND	2	G	Ground
VCC	3	P	Supply voltage
OUT1	4	O	Unipolar output, responds to positive magnetic flux density through the package.

6 Specifications

6.1 Absolute Maximum Ratings

over operating free-air temperature range (unless otherwise noted)⁽¹⁾

		MIN	MAX	UNIT
Power supply voltage	V_{CC}	-0.3	6	V
Pin voltage	OUT1, OUT2	-0.3	$V_{CC} + 0.3V$	
Output pin current	OUT1, OUT2	-5.5	5.5	mA
Magnetic flux density, B		Unlimited		T
Junction temperature, T_J		-65	150	°C
Storage temperature, T_{stg}		-65	150	°C

- (1) Operation outside the Absolute Maximum Ratings may cause permanent device damage. Absolute Maximum Ratings do not imply functional operation of the device at these or any other conditions beyond those listed under Recommended Operating Conditions. If used outside the Recommended Operating Conditions but within the Absolute Maximum Ratings, the device may not be fully functional, and this may affect device reliability, functionality, performance, and shorten the device lifetime.

6.2 ESD Ratings

			VALUE	UNIT
$V_{(ESD)}$	Electrostatic discharge	Human body model (HBM), per ANSI/ESDA/ JEDEC JS-001, all pins ⁽¹⁾	±2000	V
		Charged device model (CDM), ANSI/ESDA/ JEDEC JS-002 ⁽²⁾	±500	

- (1) JEDEC document JEP155 states that 500V HBM allows safe manufacturing with a standard ESD control process.
(2) JEDEC document JEP157 states that 250V CDM allows safe manufacturing with a standard ESD control process.

6.3 Recommended Operating Conditions

		MIN	MAX	UNIT
V_{CC}	Power supply voltage	1.65	5.5	V
V_o	Output voltage, OUT1, OUT2, OUT	0	V_{CC}	V
I_o	Output current	-5	5	mA
T_A	Ambient temperature	-40	125	°C

6.4 Thermal Information

THERMAL METRIC ⁽¹⁾		TMAG5133		UNIT
		SOT-23 (DBV)	X1LGA (ZFC)	
		3 PINS	4 PINS	
$R_{\theta JA}$	Junction-to-ambient thermal resistance	233.8	393.5	°C/W
$R_{\theta JC(top)}$	Junction-to-case (top) thermal resistance	89.1	149.7	
$R_{\theta JB}$	Junction-to-board thermal resistance	76.2	275.8	
Ψ_{JT}	Junction-to-top characterization parameter	33.1	7.1	
Ψ_{JB}	Junction-to-board characterization parameter	75.3	273.2	

- (1) For more information about traditional and new thermal metrics, see the [Semiconductor and IC Package Thermal Metrics](#) application report.

6.5 Electrical Characteristics

over free-air temperature range and $V_{CC} = 1.65\text{V}$ to 5.5V (unless otherwise noted); Typical specifications are at $T_A = 25^\circ\text{C}$ and $V_{CC} = 3.3\text{V}$ (unless otherwise noted)

PARAMETER		TEST CONDITIONS	MIN	TYP	MAX	UNIT
DIGITAL INPUT/OUTPUT						
V_{OH}	High-level output voltage	$I_{OH} = 0.5\text{mA}$	$V_{CC} - 0.4\text{ V}$		V_{CC}	V
V_{OL}	Low-level output voltage	$I_{OL} = 0.5\text{mA}$	0		0.4	V
I_{IN}	Input leakage current	$V_{OUT} = 0\text{V}, V_{CC}$	-1		1	μA
C_{OUT}	Pin capacitance	$f = 1\text{MHz}$		2		pF
POWER SUPPLY						
t_{ACTIVE}	Active time duration (pulse width)		23	28	34	μs
I_{ACTIVE}	Supply current during measurement	$T_A = 25^\circ\text{C}$		2.4	2.8	mA
		$T_A = -40^\circ\text{C}$ to 85°C			3	mA
		$T_A = 125^\circ\text{C}$			3.2	mA
I_{SLEEP}	Sleep current	$T_A = 25^\circ\text{C}$		0.32	0.6	μA
		$T_A = -40^\circ\text{C}$ to 85°C			1	μA
		$T_A = 125^\circ\text{C}$			1.75	μA
t_{ON}	Power-on time			100	500	μs
TMAG5133xxD 20Hz						
f_S	Frequency of magnetic sampling	$T_A = 25^\circ\text{C}$	13	20	27	Hz
			10	20	30	
t_S	Period of magnetic sampling	$T_A = 25^\circ\text{C}$	37	50	77	ms
			33	50	100	
I_{CCAVG}	Average current consumption $f_S = 20\text{Hz}$	$T_A = 25^\circ\text{C}$		1.8	2.0	μA
		$T_A = -40^\circ\text{C}$ to 85°C			2.6	
		$T_A = -40^\circ\text{C}$ to 125°C			3.4	

6.6 Magnetic Characteristics

over free-air temperature range and $V_{CC} = 1.65V$ to $5.5V$ (unless otherwise noted); Typical specifications are at $T_A = 25^\circ C$ and $V_{CC} = 3.3V$ (unless otherwise noted)

PARAMETER		TEST CONDITIONS	MIN	TYP	MAX	UNIT
TMAG5133Dxx 3mT						
B_{OP}	Magnetic threshold operate point	$T_A = 25^\circ C$	± 2.3	± 3	± 3.7	mT
		$T_A = -40^\circ C$ to $85^\circ C$	± 2.2	± 3	± 3.8	
		$T_A = -40^\circ C$ to $125^\circ C$	± 2.1	± 3	± 3.9	
B_{RP}	Magnetic release operate point	$T_A = 25^\circ C$	± 1.5	± 2.2	± 2.9	mT
		$T_A = -40^\circ C$ to $85^\circ C$	± 1.4	± 2.2	± 3	
		$T_A = -40^\circ C$ to $125^\circ C$	± 1.3	± 2.2	± 3.1	
B_{HYS}	Magnetic hysteresis: $ B_{OP} - B_{RP} $	$T_A = 25^\circ C$	0.26	0.8		mT
		$T_A = 85^\circ C$	0.16	0.8		
		$T_A = 125^\circ C$	0.11	0.8		

6.7 Typical Characteristics

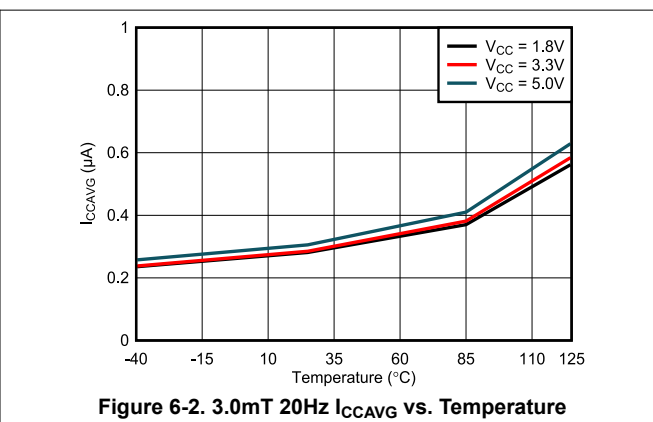
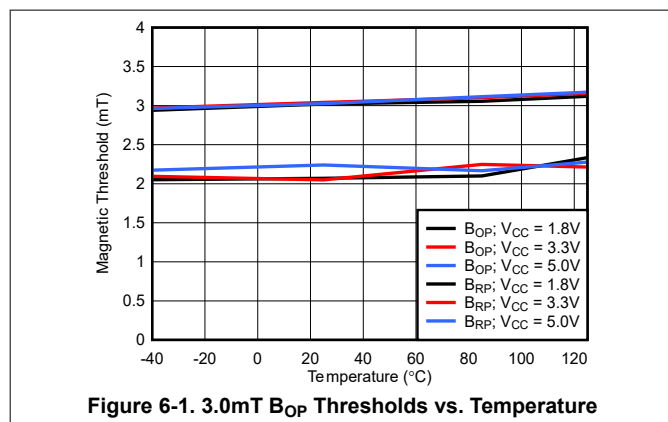

7 Detailed Description

7.1 Overview

The TMAG5133 is a Hall-effect magnetic sensor with two digital outputs that indicate when the magnetic flux density threshold has been crossed. The outputs are active low push-pull, driving the output pins low when a magnetic field is present and returning high when no field is present. As a dual-unipolar switch, the OUT1 pin responds to positive magnetic flux density through the package whereas the OUT2 pin responds to a negative magnetic flux density through the package. The TMAG5133 periodically samples the Hall sensor according to the sampling rate. After sampling the sensor, the device enters a low-power sleep state to conserve power.

7.2 Functional Block Diagram

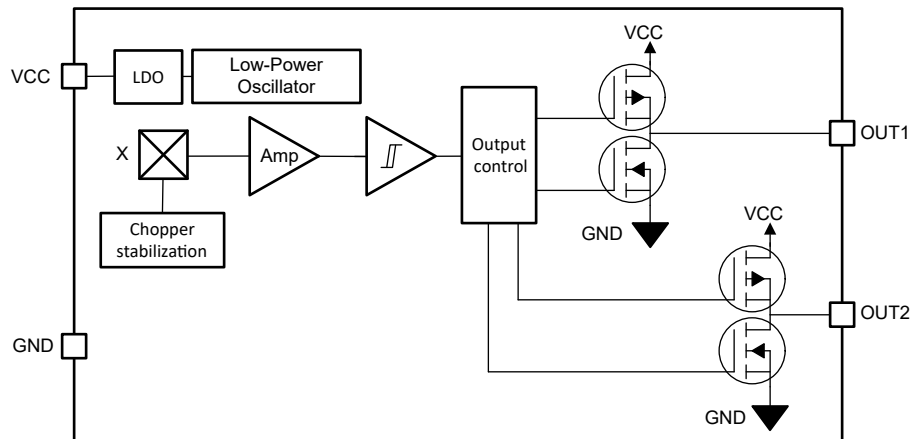

7.3 Feature Description

7.3.1 X1LGA Magnetic Flux Direction

The TMAG5133 X1LGA package detects the magnetic flux density which is horizontal to the package marking surface.

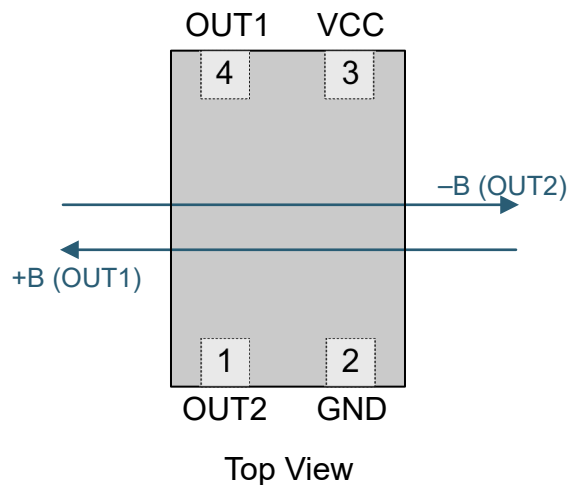

Figure 7-1. Direction of Sensitivity in X1LGA Package

Magnetic flux that travels from the pin 2 and 3 side of the package to the pin 1 and 4 side of the package is considered positive by the TMAG5133 X1LGA. This condition exists when a south magnetic pole is near pins 1 and 4 of the device.

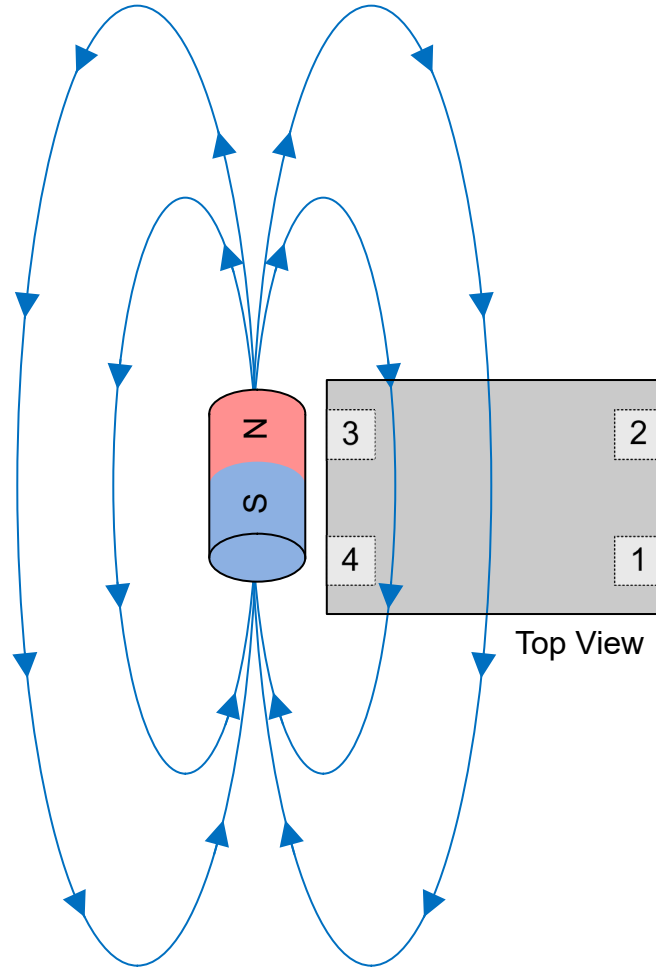

Figure 7-2. Positive Flux Direction Offset

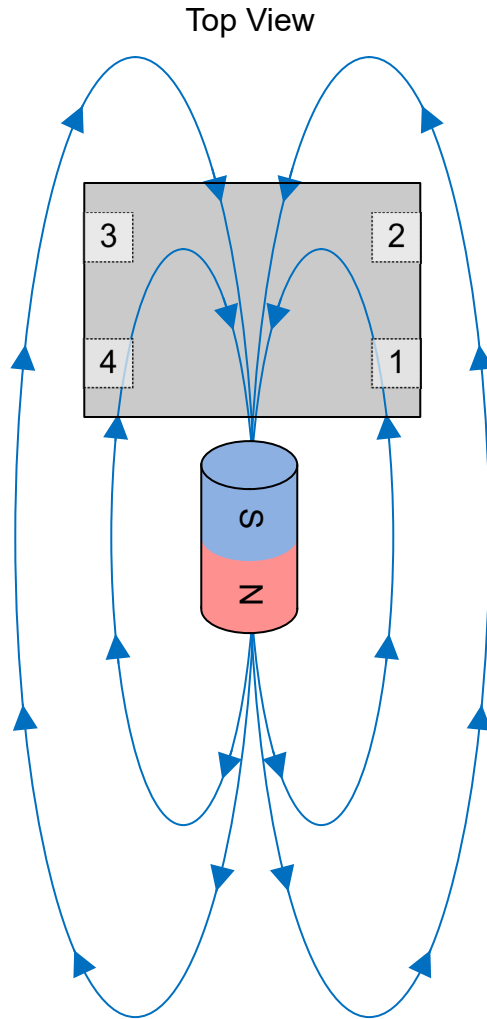

Figure 7-3. Positive Flux Direction side

The TMAG5133 X1LGA package is available with two unipolar outputs. OUT1 responds to a positive magnetic flux density through the package, which can be seen for example when a south magnet is located at the pin 1 and 4 side of the package, or when a north magnet is located at the pin 3 and 2 side of the package. OUT2 responds to a negative magnetic flux density through the package, which can be seen for example when a north magnet is located at the pin 1 and 4 side of the package, or when a south magnet is located at the pin 3 and 2 side of the package. [Figure 7-4](#) illustrates the behavior of OUT1 and OUT2.

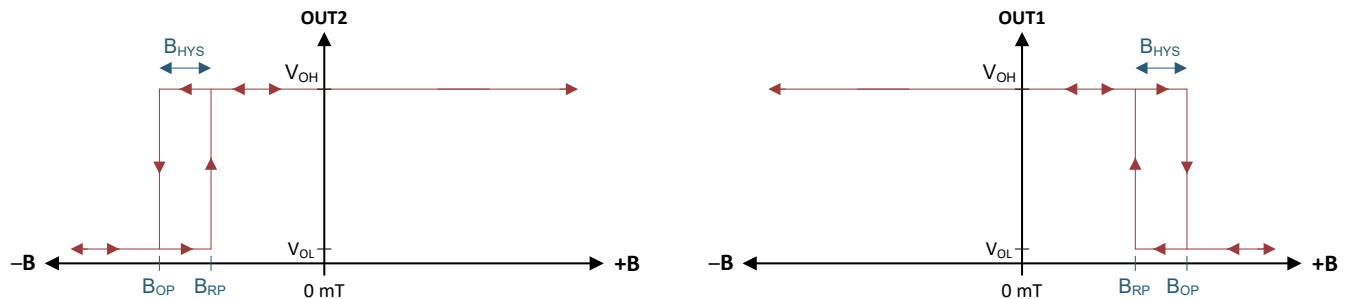

Figure 7-4. Unipolar Output Response

7.3.3 Sampling Rate

When the TMAG5133 powers up, the device measures the first magnetic sample and sets the output within t_{ON} . The output is latched, and the device enters a low-power sleep state. After each t_S time has passed, the device measures a new sample and updates the output, if necessary. If the magnetic field does not change between periods, the output also does not change.

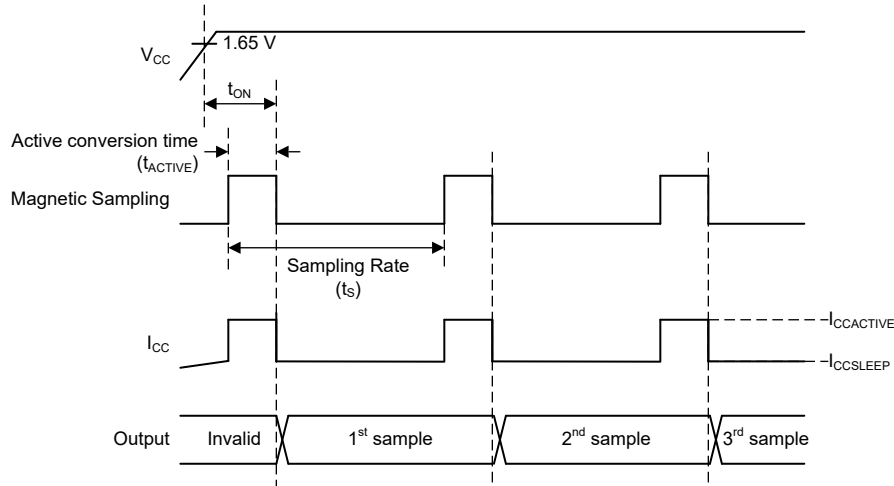

Figure 7-5. Sampling Rate Diagram

7.3.4 Hall Element Location

Figure 7-6 shows the sensing element location inside the X1LGA package.

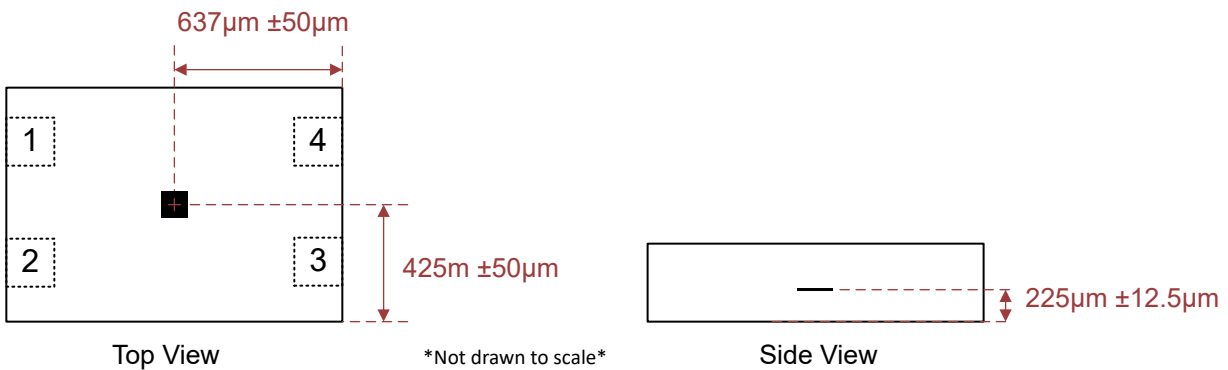

Figure 7-6. Hall Element Location

7.4 Device Functional Modes

The TMAG5133 always operates in a continuous conversion mode when the *Recommended Operating Conditions* are met.

8 Application and Implementation

Note

Information in the following applications sections is not part of the TI component specification, and TI does not warrant its accuracy or completeness. TI's customers are responsible for determining suitability of components for their purposes, as well as validating and testing their design implementation to confirm system functionality.

8.1 Application Information

The TMAG5133 is a Hall-effect switch used to detect the proximity of a magnet, which is often attached to a movable component within the system. When the magnet comes sufficiently close to the sensor and induces a magnetic flux density that exceeds the B_{OP} threshold along the TMAG5133 axis of sensitivity, the output of the sensor is pulled low to GND. This low output can be read by a GPIO pin on a controller, enabling the system to recognize that the magnet has crossed the threshold, thereby indicating the position or movement of the component. This application is common in various fields, such as industrial automation and consumer electronics, where precise detection of position or movement is critical.

Due to the complex, non-linear behavior of magnets, it may be difficult to determine the appropriate magnet characteristics required to ensure the system works as intended. Therefore, TI recommends to begin the design process with experimentation to solve for a design that works. To help facilitate rapid design iteration, the [TI Magnetic Sense Simulator \(TIMSS\)](#) web tool provides a visual interface that emulates typical sensor performance in system designs. TIMSS simulations provide an understanding of expected magnetic field behavior across a range of motion, and the simulations are run in a few seconds.

8.2 Typical Application

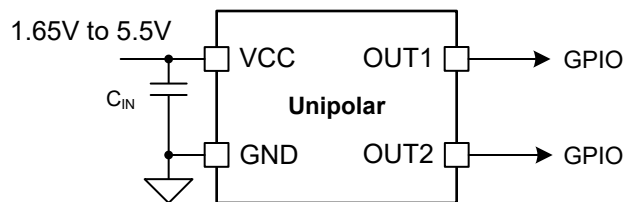

Figure 8-1. Typical Application Schematic

8.2.1 Design Requirements

This section provides an example using the [TI Magnetic Sense Simulator \(TIMSS\)](#) web tool for a magnet slide-by application. The following table lists the design parameters related to the movement of the magnet on the x-axis.

Table 8-1. Design Parameters

PARAMETER	VALUE
Supply voltage (V_{CC})	3.3V
Bypass capacitor	0.1 μ F
Part number	TMAG5133D5D
Magnet range of motion	10mm
Magnet length	3mm
Magnet width	3mm
Magnet height	3mm
Magnet type	N35

8.2.2 Detailed Design Procedure

As the magnet travels from the starting position (–5mm on X-axis) to the final position (5mm on X-axis), the magnetic flux density seen by the TMAG5133 across the axis of sensitivity changes.

At the magnet starting position, the TMAG5133 output is high because the magnetic flux density is less than B_{OP} . As the magnet moves along the X-axis towards the sensor, the magnetic flux density crosses the B_{OP} threshold of the TMAG5133 at a displacement of –3.1mm, making the output go low. As the magnet continues to move along the X-axis past the origin, the magnetic flux density begins to decrease. At a displacement of 3.4mm the B_{RP} threshold is crossed and the output goes high.

8.3 Power Supply Recommendations

The TMAG5133 supports a supply range of 1.65V to 5.5V. A minimum 0.1µF decoupling capacitor must be placed as close to the device as possible.

8.4 Layout

8.4.1 Layout Guidelines

Magnetic fields pass through most non-ferromagnetic materials with no significant disturbance. Embedding Hall-effect sensors within plastic or aluminum enclosures and sensing magnets on the outside is common practice. Magnetic fields also easily pass through most printed circuit boards (PCBs), which makes the placement of the magnet on the opposite side possible.

8.4.2 Layout Example

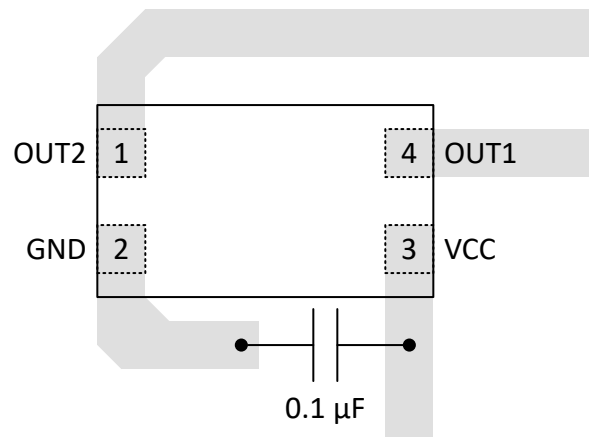

Figure 8-2. X1LGA Layout Example

9 Revision History

NOTE: Page numbers for previous revisions may differ from page numbers in the current version.

Changes from Revision * (March 2025) to Revision A (June 2025)	Page
• Changed data sheet status from Advance Information to Production Data.....	1

10 Mechanical, Packaging, and Orderable Information

The following pages include mechanical, packaging, and orderable information. This information is the most current data available for the designated devices. This data is subject to change without notice and revision of this document. For browser-based versions of this data sheet, refer to the left-hand navigation.

PACKAGING INFORMATION

Orderable part number	Status (1)	Material type (2)	Package Pins	Package qty Carrier	RoHS (3)	Lead finish/ Ball material (4)	MSL rating/ Peak reflow (5)	Op temp (°C)	Part marking (6)
TMAG5133D5DZFCR	Active	Production	NFBGA (ZFC) 4	3000 LARGE T&R	No	NIAU	Level-2-260C-1 YEAR	-40 to 125	

(1) **Status:** For more details on status, see our [product life cycle](#).

(2) **Material type:** When designated, preproduction parts are prototypes/experimental devices, and are not yet approved or released for full production. Testing and final process, including without limitation quality assurance, reliability performance testing, and/or process qualification, may not yet be complete, and this item is subject to further changes or possible discontinuation. If available for ordering, purchases will be subject to an additional waiver at checkout, and are intended for early internal evaluation purposes only. These items are sold without warranties of any kind.

(3) **RoHS values:** Yes, No, RoHS Exempt. See the [TI RoHS Statement](#) for additional information and value definition.

(4) **Lead finish/Ball material:** Parts may have multiple material finish options. Finish options are separated by a vertical ruled line. Lead finish/Ball material values may wrap to two lines if the finish value exceeds the maximum column width.

(5) **MSL rating/Peak reflow:** The moisture sensitivity level ratings and peak solder (reflow) temperatures. In the event that a part has multiple moisture sensitivity ratings, only the lowest level per JEDEC standards is shown. Refer to the shipping label for the actual reflow temperature that will be used to mount the part to the printed circuit board.

(6) **Part marking:** There may be an additional marking, which relates to the logo, the lot trace code information, or the environmental category of the part.

Multiple part markings will be inside parentheses. Only one part marking contained in parentheses and separated by a "-" will appear on a part. If a line is indented then it is a continuation of the previous line and the two combined represent the entire part marking for that device.

Important Information and Disclaimer: The information provided on this page represents TI's knowledge and belief as of the date that it is provided. TI bases its knowledge and belief on information provided by third parties, and makes no representation or warranty as to the accuracy of such information. Efforts are underway to better integrate information from third parties. TI has taken and continues to take reasonable steps to provide representative and accurate information but may not have conducted destructive testing or chemical analysis on incoming materials and chemicals. TI and TI suppliers consider certain information to be proprietary, and thus CAS numbers and other limited information may not be available for release.

In no event shall TI's liability arising out of such information exceed the total purchase price of the TI part(s) at issue in this document sold by TI to Customer on an annual basis.

TAPE AND REEL INFORMATION

QUADRANT ASSIGNMENTS FOR PIN 1 ORIENTATION IN TAPE

*All dimensions are nominal

Device	Package Type	Package Drawing	Pins	SPQ	Reel Diameter (mm)	Reel Width W1 (mm)	A0 (mm)	B0 (mm)	K0 (mm)	P1 (mm)	W (mm)	Pin1 Quadrant
TMAG5133D5DZFCR	NFBGA	ZFC	4	3000	180.0	8.4	1.07	1.47	0.52	4.0	8.0	Q3

TAPE AND REEL BOX DIMENSIONS

*All dimensions are nominal

Device	Package Type	Package Drawing	Pins	SPQ	Length (mm)	Width (mm)	Height (mm)
TMAG5133D5DZFCR	NFBGA	ZFC	4	3000	338.1	338.1	20.6

ZFC0004A

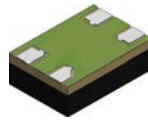

PACKAGE OUTLINE

X1LGA - 0.42 mm max height

LAND GRID ARRAY

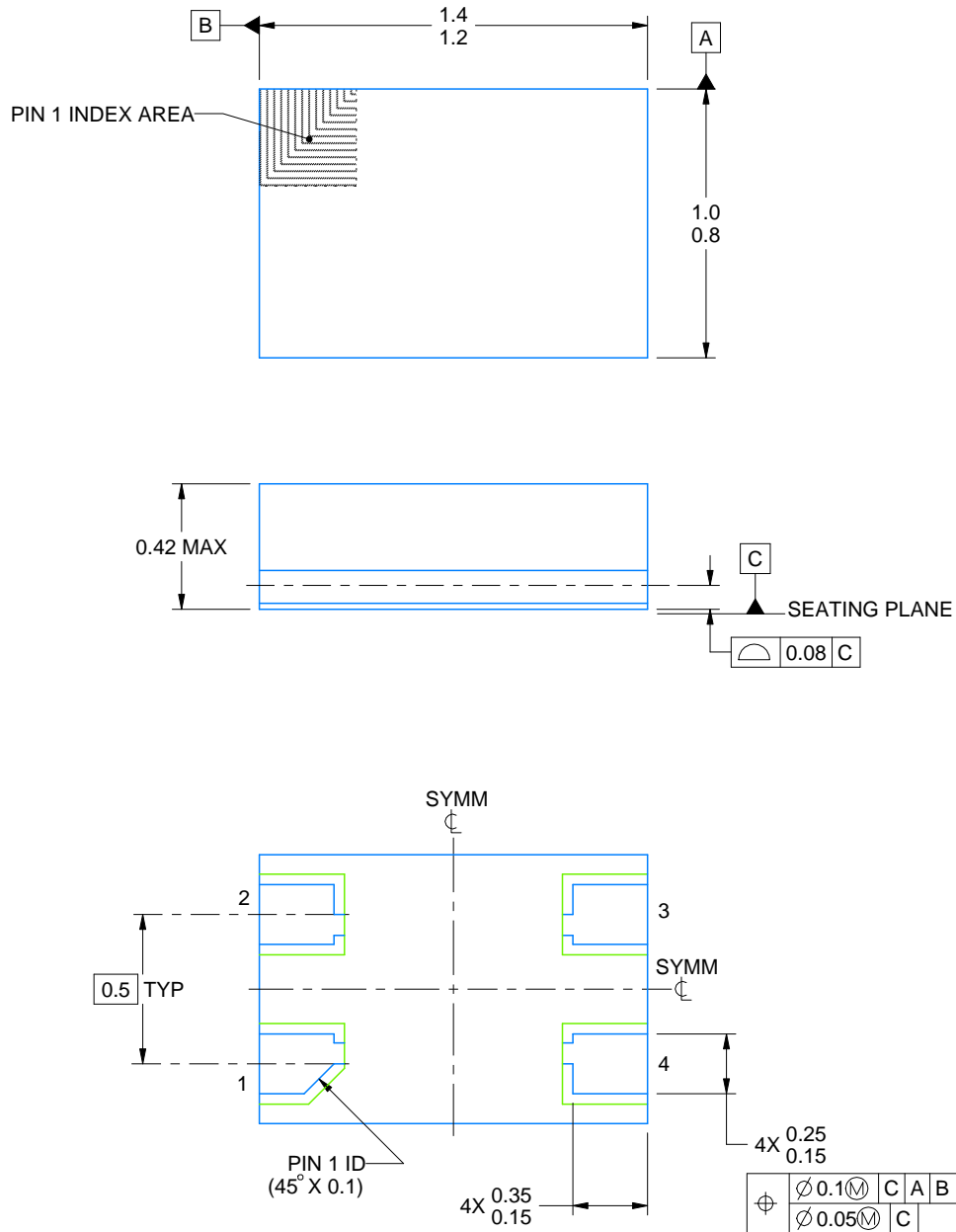

4229561/C 10/2024

NOTES:

1. All linear dimensions are in millimeters. Any dimensions in parenthesis are for reference only. Dimensioning and tolerancing per ASME Y14.5M.
2. This drawing is subject to change without notice.

EXAMPLE BOARD LAYOUT

ZFC0004A

X1LGA - 0.42 mm max height

LAND GRID ARRAY

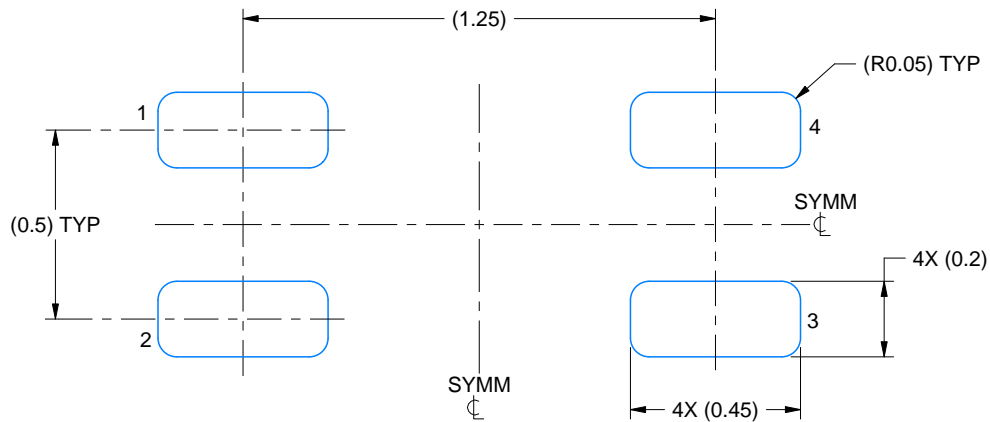

LAND PATTERN EXAMPLE

EXPOSED METAL SHOWN
SCALE: 50X

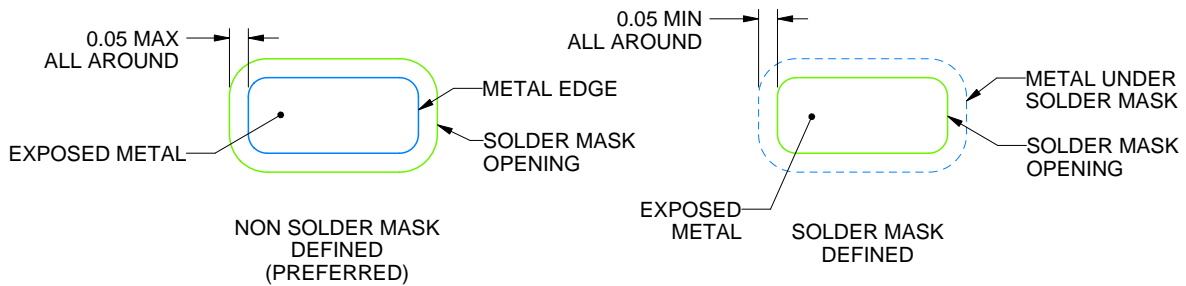

SOLDER MASK DETAILS

NOT TO SCALE

4229561/C 10/2024

NOTES: (continued)

- Final dimensions may vary due to manufacturing tolerance considerations and also routing constraints. For information, see Texas Instruments literature number SPRAA99 (www.ti.com/lit/spraa99).

EXAMPLE STENCIL DESIGN

ZFC0004A

X1LGA - 0.42 mm max height

LAND GRID ARRAY

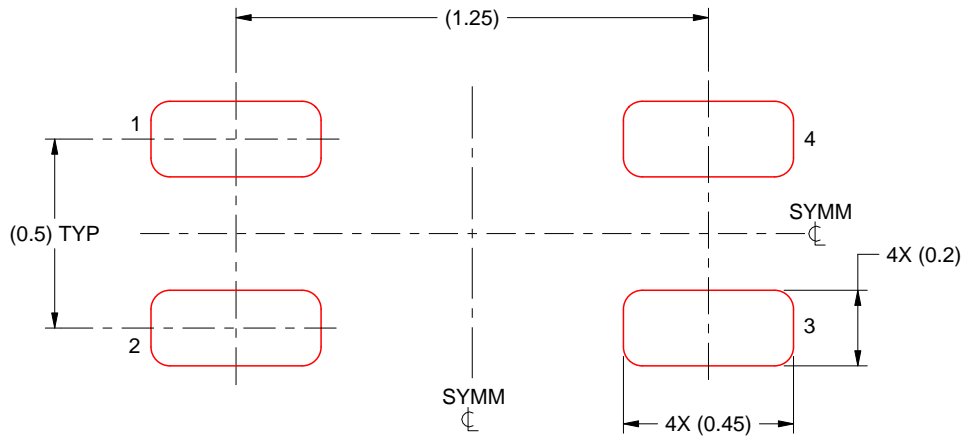

SOLDER PASTE EXAMPLE
BASED ON 0.100 mm THICK STENCIL
SCALE: 50X

4229561/C 10/2024

NOTES: (continued)

4. Laser cutting apertures with trapezoidal walls and rounded corners may offer better paste release.

IMPORTANT NOTICE AND DISCLAIMER

TI PROVIDES TECHNICAL AND RELIABILITY DATA (INCLUDING DATA SHEETS), DESIGN RESOURCES (INCLUDING REFERENCE DESIGNS), APPLICATION OR OTHER DESIGN ADVICE, WEB TOOLS, SAFETY INFORMATION, AND OTHER RESOURCES "AS IS" AND WITH ALL FAULTS, AND DISCLAIMS ALL WARRANTIES, EXPRESS AND IMPLIED, INCLUDING WITHOUT LIMITATION ANY IMPLIED WARRANTIES OF MERCHANTABILITY, FITNESS FOR A PARTICULAR PURPOSE OR NON-INFRINGEMENT OF THIRD PARTY INTELLECTUAL PROPERTY RIGHTS.

These resources are intended for skilled developers designing with TI products. You are solely responsible for (1) selecting the appropriate TI products for your application, (2) designing, validating and testing your application, and (3) ensuring your application meets applicable standards, and any other safety, security, regulatory or other requirements.

These resources are subject to change without notice. TI grants you permission to use these resources only for development of an application that uses the TI products described in the resource. Other reproduction and display of these resources is prohibited. No license is granted to any other TI intellectual property right or to any third party intellectual property right. TI disclaims responsibility for, and you will fully indemnify TI and its representatives against, any claims, damages, costs, losses, and liabilities arising out of your use of these resources.

TI's products are provided subject to [TI's Terms of Sale](#) or other applicable terms available either on [ti.com](https://www.ti.com) or provided in conjunction with such TI products. TI's provision of these resources does not expand or otherwise alter TI's applicable warranties or warranty disclaimers for TI products.

TI objects to and rejects any additional or different terms you may have proposed.

Mailing Address: Texas Instruments, Post Office Box 655303, Dallas, Texas 75265
Copyright © 2025, Texas Instruments Incorporated