

## HIGH-SPEED DIFFERENTIAL LINE DRIVERS AND RECEIVERS

### FEATURES

- Typically Meets or Exceeds ANSI TIA/EIA-644-1995 Standard
- Operates From a Single 2.4-V to 3.6-V Supply
- Signaling Rates up to 400 Mbit/s
- Bus-Terminal ESD Exceeds 12 kV
- Low-Voltage Differential Signaling With Typical Output Voltages of 285 mV and a 100-Ω Load
- Propagation Delay Times
  - Driver: 1.7-ns Typical
  - Receiver: 3.7-ns Typical
  - Driver: 25-mW Typical
  - Receiver: 60-mW Typical
- Power Dissipation at 200 MHz
  - Driver: 25-mW Typical
  - Receiver: 60-mW Typical
- LVTTTL Input Levels Are 5-V Tolerant
- Receiver Maintains High Input Impedance
- Receiver Has Open-Circuit Fail Safe
- Available in Thin Shrink Outline Packaging With 20-mil Lead Pitch

### DESCRIPTION

The SN65LVDS1050 is similar to the SN65LVDS050 except that it is characterized for operation with a lower supply voltage range and packaged in the thin shrink outline package for portable battery-powered applications.

The differential line drivers and receivers use low-voltage differential signaling (LVDS) to achieve signaling rates as high as 400 Mbps. The drivers provide a minimum differential output voltage magnitude of 247 mV into a 100-Ω load and receipt of 100-mV signals with up to 1 V of ground potential difference between a transmitter and receiver.

The intended application of this device and signaling technique is for point-to-point baseband data transmission over controlled impedance media of approximately 100-Ω characteristic impedance. The transmission media may be printed-circuit board traces, backplanes, or cables. Note: The ultimate rate and distance of data transfer is dependent upon the attenuation characteristics of the media, the noise coupling to the environment and other application-specific characteristics.

The SN65LVDS1050 is characterized for operation from -40°C to 85°C.

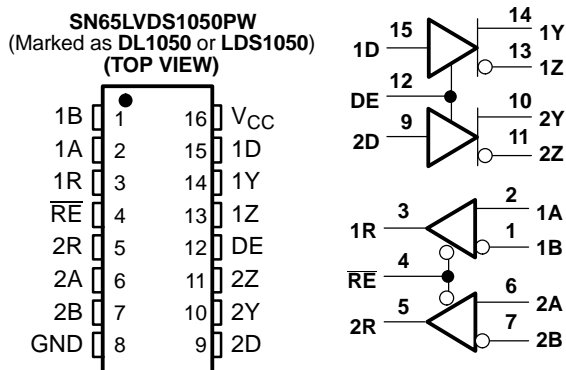

DRIVER FUNCTION TABLE

INPUTS		OUTPUTS	
D	DE	Y	Z
L	H	L	H
H	H	H	L
Open	H	L	H
X	L	Z	Z

H = high level, L = low level, Z = high impedance, X = don't care

RECEIVER FUNCTION TABLE

INPUTS		OUTPUT
$V_{ID} = V_A - V_B$	$\overline{RE}$	R
$V_{ID} \geq 100$ mV	L	H
$-100$ mV < $V_{ID} < 100$ mV	L	?
$V_{ID} \leq -100$ mV	L	L
Open	L	H
X	H	Z

H = high level, L = low level, Z = high impedance, X = don't care



Please be aware that an important notice concerning availability, standard warranty, and use in critical applications of Texas Instruments semiconductor products and disclaimers thereto appears at the end of this data sheet.

EQUIVALENT INPUT AND OUTPUT SCHEMATIC DIAGRAMS

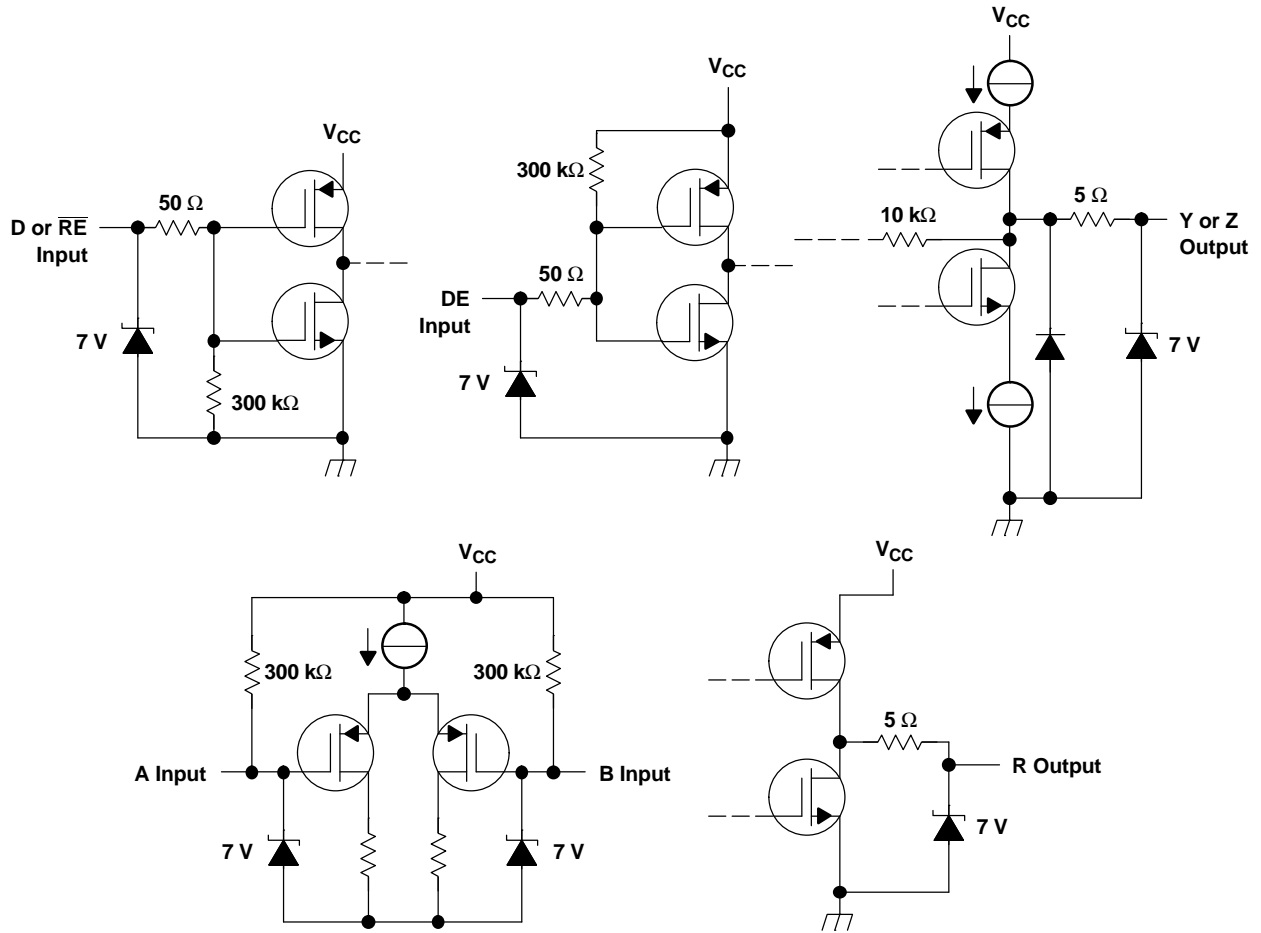

## ABSOLUTE MAXIMUM RATINGS

over operating free-air temperature range (unless otherwise noted) (1)

		UNIT
Supply voltage range, $V_{CC}$ (2)		-0.5 V to 4 V
Voltage range (D, R, DE, $\overline{RE}$ )		-0.5 V to 6 V
Voltage range (Y, Z, A, and B)		-0.5 V to 4 V
Electrostatic discharge	Y, Z, A, B , and GND (3)	Class 3, A:12 kV, B:600 V
	All terminals	Class 3, A:7 kV, B:500 V
Continuous power dissipation		See Dissipation Rating Table
Storage temperature range		-65°C to 150°C
Lead temperature 1,6 mm (1/16 inch) from case for 10 seconds		250°C

- (1) Stresses beyond those listed under "absolute maximum ratings" may cause permanent damage to the device. These are stress ratings only, and functional operation of the device at these or any other condition beyond those indicated under "recommended operating conditions" is not implied. Exposure to absolute-maximum-rated conditions for extended periods may affect device reliability.
- (2) All voltage values, except differential I/O bus voltages are with respect to network ground terminal.
- (3) Tested in accordance with MIL-STD-883C Method 3015.7.

## DISSIPATION RATING TABLE

PACKAGE	$T_A \leq 25^\circ\text{C}$ POWER RATING	DERATING FACTOR ABOVE $T_A = 25^\circ\text{C}$	$T_A = 85^\circ\text{C}$ POWER RATING
PW	774 mW	6.2 mW/°C	402 mW

## RECOMMENDED OPERATING CONDITIONS (1)

	MIN	NOM	MAX	UNIT
Supply voltage, $V_{CC}$	2.4	2.7	3.6	V
High-level input voltage, $V_{IH}$	2			V
Low-level input voltage, $V_{IL}$			0.8	V
Magnitude of differential input voltage, $ V_{ID} $	0.1		0.6	V
Driver output voltage, $V_{OY}$ or $V_{OZ}$	0		2.4	V
Magnitude of differential output voltage with disabled driver, $ V_{OD(dis)} $			520	mV
Common-mode input voltage, $V_{IC}$ (see Figure 5)	0		$2.4 - \frac{ V_{ID} }{2}$	V
			$V_{CC} - 0.8$	
Operating free-air temperature, $T_A$	40		85	°C

- (1) The common-mode input voltage,  $V_{IC}$ , is not fully 644 compliant when  $V_{CC} = 2.4$  V.

## DEVICE ELECTRICAL CHARACTERISTICS

over recommended operating conditions (unless otherwise noted)

PARAMETER	TEST CONDITIONS	MIN	TYP (1)	MAX	UNIT
$I_{CC}$ Supply current	Driver and receiver enabled, No receiver load, Driver $R_L = 100 \Omega$		12	20	mA
	Driver enabled, Receiver disabled, $R_L = 100 \Omega$		10	16	
	Driver disabled, Receiver enabled, No load		3	6	
	Disabled		0.5	1	

- (1) All typical values are at 25°C and with a 2.7-V supply.

## DRIVER ELECTRICAL CHARACTERISTICS

over recommended operating conditions (unless otherwise noted)

PARAMETER		TEST CONDITIONS	MIN	TYP	MAX	UNIT
$ V_{OD} $	Differential output voltage magnitude	$R_L=100\Omega$ , See Figure 1 and Figure 2	247	285	454	mV
$\Delta V_{OD} $	Change in differential output voltage magnitude between logic states		50		50	
$V_{OC(SS)}$	Steady-state common-mode output voltage	See Figure 3	1.125		1.375	V
$\Delta V_{OC(SS)}$	Change in steady-state common-mode output voltage between logic states		50		50	mV
$V_{OC(PP)}$	Peak-to-peak common-mode output voltage			50	150	mV
$I_{IH}$	High-level input current	DE	$V_{IH}=5\text{ V}$	0.5	20	$\mu\text{A}$
		D		2	20	
$I_{IL}$	Low-level input current	DE	$V_{IL}=0.8\text{ V}$	0.5	10	$\mu\text{A}$
		D		2	20	
$I_{OS}$	Short-circuit output current	$V_{OY}$ or $V_{OZ}=0\text{ V}$		3	10	mA
		$V_{OD}=0\text{ V}$		3	10	
$I_{O(OFF)}$	Off-state output current	$DE=0\text{ V}$ , $V_{OY}=V_{OZ}=0\text{ V}$				$\mu\text{A}$
		$DE=V_{CC}$ , $V_{OY}=V_{OZ}=0\text{ V}$ , $V_{CC} < 1.5\text{ V}$	-1		1	
$C_{IN}$	Input capacitance			3		pF

## RECEIVER ELECTRICAL CHARACTERISTICS

over recommended operating conditions (unless otherwise noted)

PARAMETER		TEST CONDITIONS	MIN	TYP (1)	MAX	UNIT
$V_{ITH+}$	Positive-going differential input voltage threshold	See Figure 5 and Table 1			100	mV
$V_{ITH-}$	Negative-going differential input voltage threshold		100			
$V_{OH}$	High-level output voltage	$I_{OH}=-8\text{ mA}$	2			V
$V_{OL}$	Low-level output voltage	$I_{OL}=8\text{ mA}$			0.4	V
$I_I$	Input current (A or B inputs)	$V_I=0$	2		20	$\mu\text{A}$
		$V_I=2.4\text{ V}$	1.2			
$I_{I(OFF)}$	Power-off input current (A or B inputs)	$V_{CC}=0$			$\pm 20$	$\mu\text{A}$
$I_{IH}$	High-level input current (enables)	$V_{IH}=5\text{ V}$			$\pm 10$	$\mu\text{A}$
$I_{IL}$	Low-level input current (enables)	$V_{IL}=0.8\text{ V}$			$\pm 10$	$\mu\text{A}$
$I_{OZ}$	High-impedance output current	$V_O = 0$ or $5\text{ V}$			$\pm 10$	$\mu\text{A}$

(1) All typical values are at 25°C and with a 2.7-V supply.

## DRIVER SWITCHING CHARACTERISTICS

over recommended operating conditions (unless otherwise noted)

PARAMETER	TEST CONDITIONS	MIN	TYP (1)	MAX	UNIT
$t_{PLH}$	Propagation delay time, low-to-high-level output		1.7	2.7	ns
$t_{PHL}$	Propagation delay time, high-to-low-level output		1.7	3	ns
$t_r$	Differential output signal rise time	$R_L=100\Omega$ , $C_L=10$ pF, See Figure 2	0.8	1	ns
$t_f$	Differential output signal fall time		0.8	1	ns
$t_{sk(p)}$	Pulse skew ( $t_{pHL} - t_{pLH}$ )		300		ps
$t_{sk(o)}$	Channel-to-channel output skew (2)		150		ps
$t_{en}$	Enable time	See Figure 4	7.8	10	ns
$t_{dis}$	Disable time		6.6	10	ns

(1) All typical values are at 25°C and with a 2.7-V supply.

(2)  $t_{sk(o)}$  is the maximum delay time difference between drivers on the same device.

## RECEIVER SWITCHING CHARACTERISTICS

over recommended operating conditions (unless otherwise noted)

PARAMETER	TEST CONDITIONS	MIN	TYP (1)	MAX	UNIT
$t_{PLH}$	Propagation delay time, low-to-high-level output	$C_L=10$ pF, See Figure 6	3.7	5.2	ns
$t_{PHL}$	Propagation delay time, high-to-low-level output		3.7	4.5	ns
$t_{sk(p)}$	Pulse skew ( $t_{pHL} - t_{pLH}$ )		0.3		ns
$t_r$	Output signal rise time		0.8	1.5	ns
$t_f$	Output signal fall time		0.8	1.5	ns
$t_{PZH}$	Propagation delay time, high-level-to-high-impedance output	See Figure 7	5.4		ns
$t_{PZL}$	Propagation delay time, low-level-to-low-impedance output		6.3		ns
$t_{PHZ}$	Propagation delay time, high-impedance-to-high-level output		6.1		ns
$t_{PLZ}$	Propagation delay time, low-impedance-to-high-level output		6.9		ns

(1) All typical values are at 25°C and with a 2.7-V supply.

PARAMETER MEASUREMENT INFORMATION

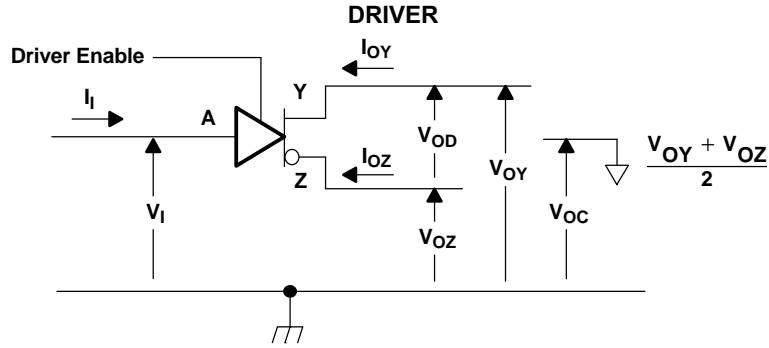
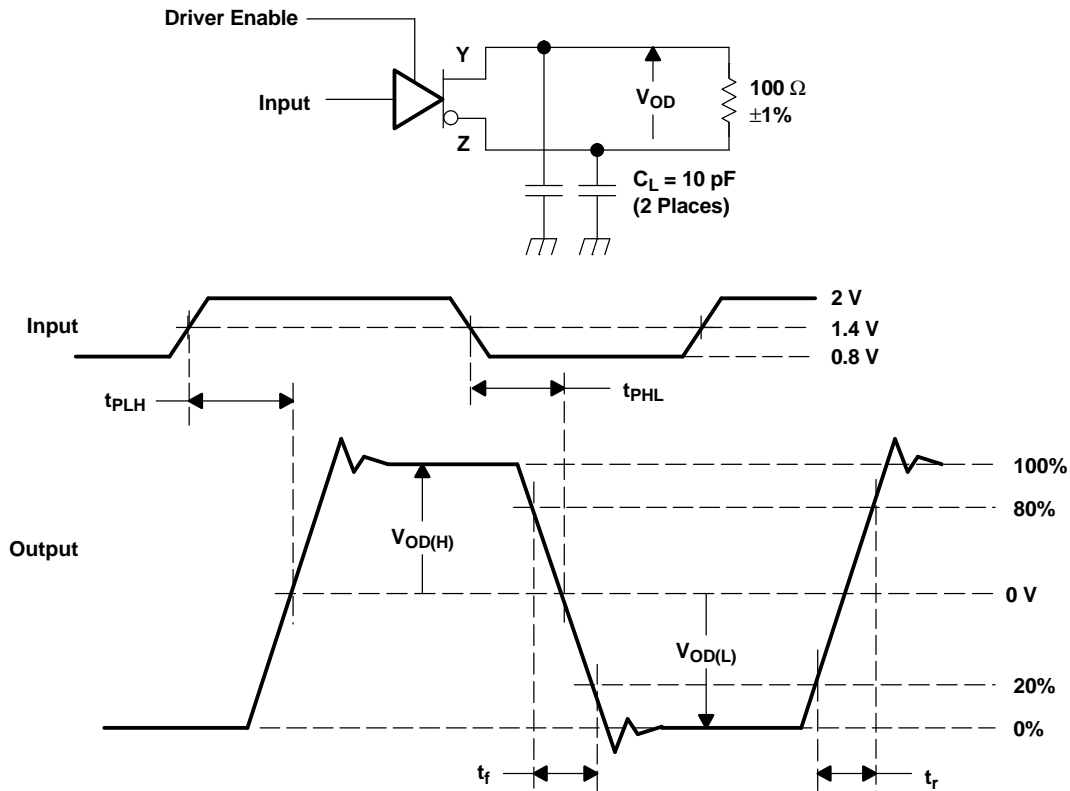
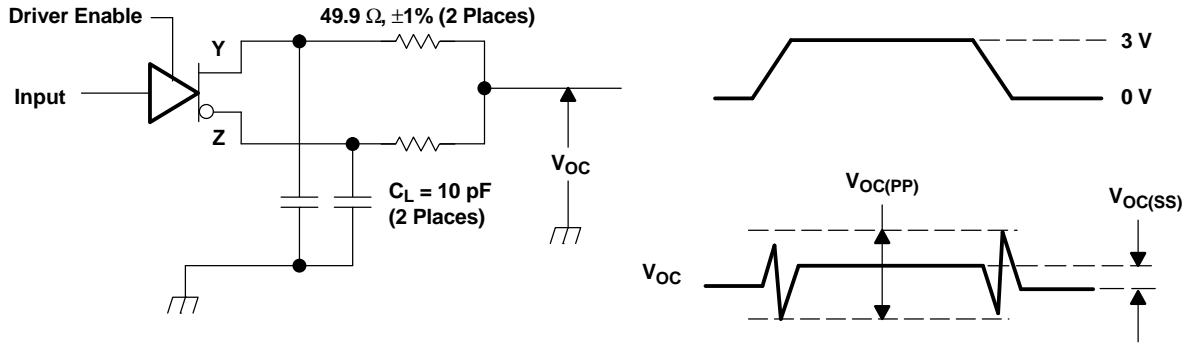

Figure 1. Driver Voltage and Current Definitions



All input pulses are supplied by a generator having the following characteristics:  $t_r$  or  $t_f \leq 1$  ns, pulse repetition rate (PRR) = 50 Mpps, pulse width =  $10 \pm 0.2$  ns.  $C_L$  includes instrumentation and fixture capacitance within 0,06 mm of the D.U.T.

Figure 2. Test Circuit, Timing, and Voltage Definitions for the Differential Output Signal



All input pulses are supplied by a generator having the following characteristics:  $t_r$  or  $t_f \leq 1$  ns, pulse repetition rate (PRR) = 50 Mpps, pulse width =  $10 \pm 0.2$  ns. C<sub>L</sub> includes instrumentation and fixture capacitance within 0,06 mm of the D.U.T. The measurement of V<sub>Oc(PP)</sub> is made on test equipment with a -3 dB bandwidth of at least 300 MHz.

Figure 3. Test Circuit and Definitions for the Driver Common-Mode Output Voltage

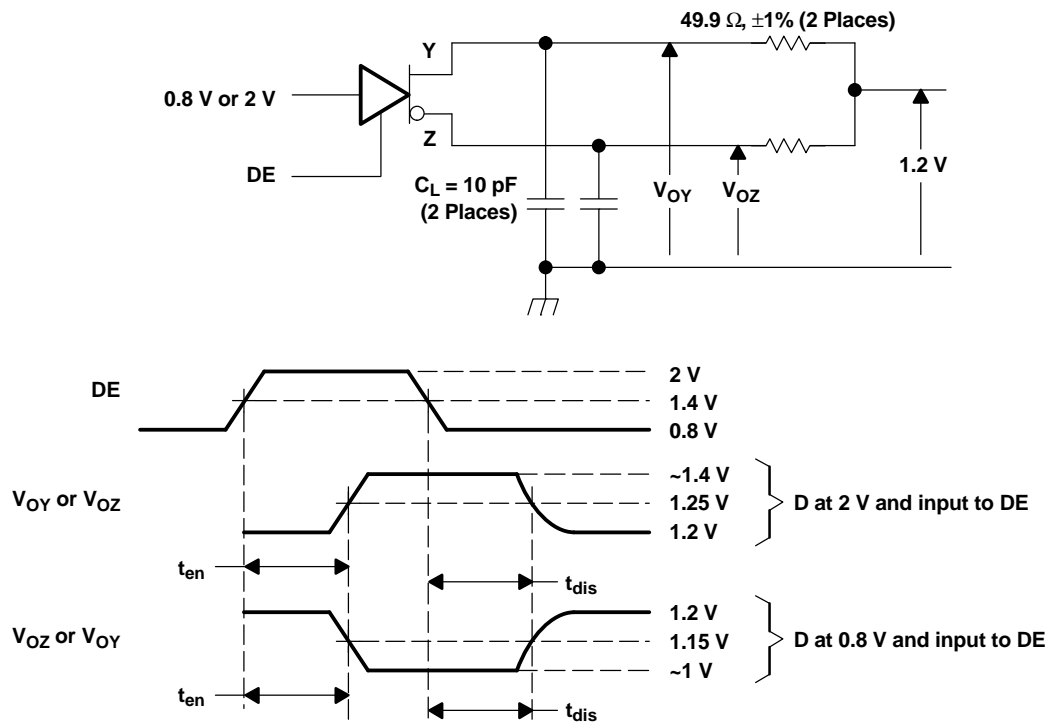

All input pulses are supplied by a generator having the following characteristics:  $t_r$  or  $t_f \leq 1$  ns, pulse repetition rate (PRR) = 0.5 Mpps, pulse width =  $500 \pm 10$  ns. C<sub>L</sub> includes instrumentation and fixture capacitance within 0,06 mm of the D.U.T.

Figure 4. Driver Enable and Disable Time Circuit and Definitions

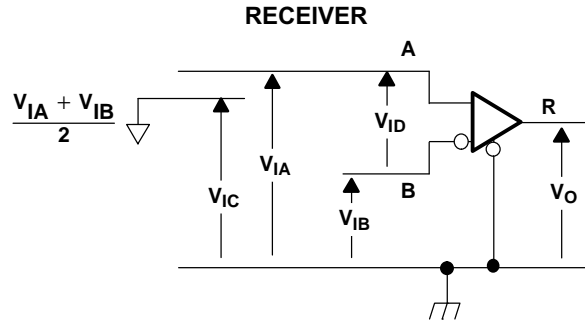
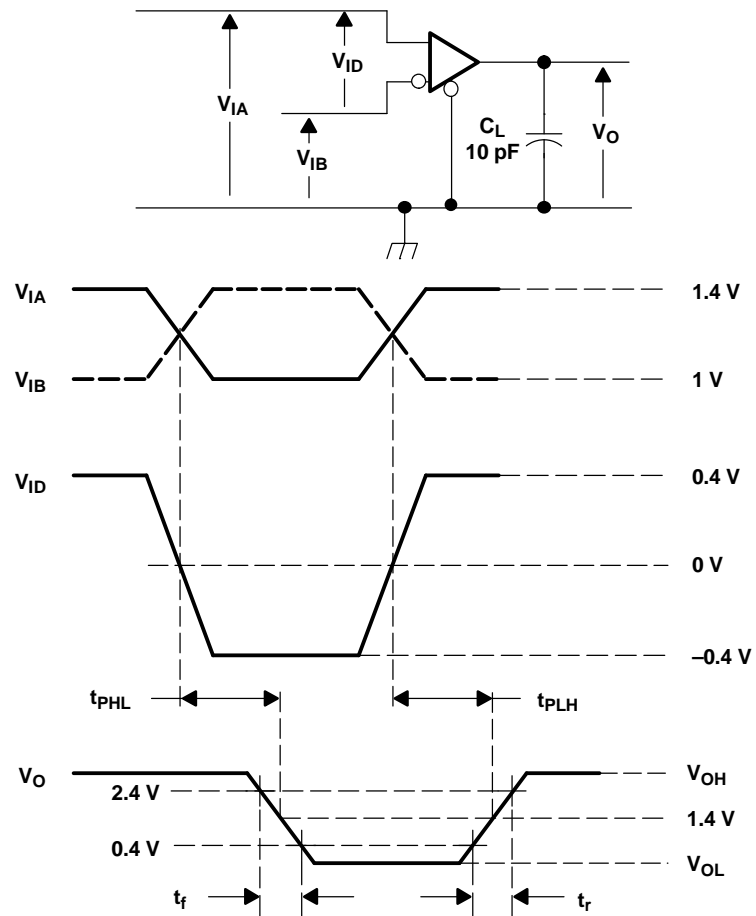

Figure 5. Receiver Voltage Definitions

Table 1. Receiver Minimum and Maximum Input Threshold Test Voltages

APPLIED VOLTAGES (V)		RESULTING DIFFERENTIAL INPUT VOLTAGE (mV)	RESULTING COMMON-MODE INPUT VOLTAGE (V)
$V_{IA}$	$V_{IB}$	$V_{ID}$	$V_{IC}$
1.25	1.15	100	1.2
1.15	1.25	100	1.2
2.4	2.3	100	2.35
2.3	2.4	100	2.35
0.1	0	100	0.05
0	0.1	100	0.05
1.5	0.9	600	1.2
0.9	1.5	600	1.2
2.4	1.8	600	2.1
1.8	2.4	600	2.1
0.6	0	600	0.3
0	0.6	600	0.3



All input pulses are supplied by a generator having the following characteristics:  $t_r$  or  $t_f \leq 1 \text{ ns}$ , pulse repetition rate (PRR) = 50 Mpps, pulse width =  $10 \pm 0.2 \text{ ns}$ .  $C_L$  includes instrumentation and fixture capacitance within 0,06 m of the D.U.T.

**Figure 6. Timing Test Circuit and Waveforms**

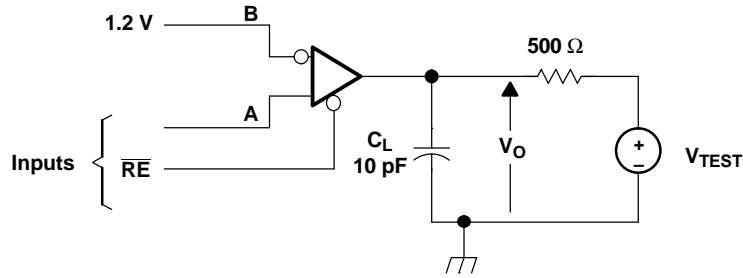

All input pulses are supplied by a generator having the following characteristics:  $t_r$  or  $t_f \leq 1$  ns, pulse repetition rate (PRR) = 0.5 Mpps, pulse width =  $500 \pm 10$  ns.  $C_L$  includes instrumentation and fixture capacitance within 0,06 m of the D.U.T.

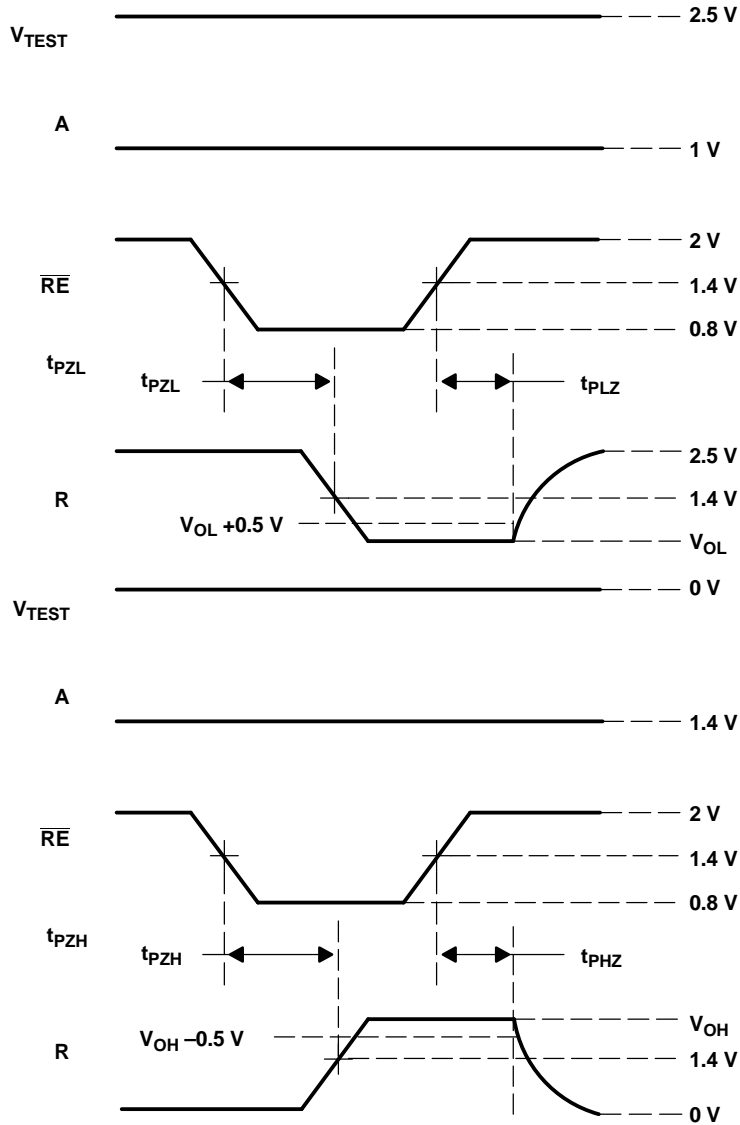
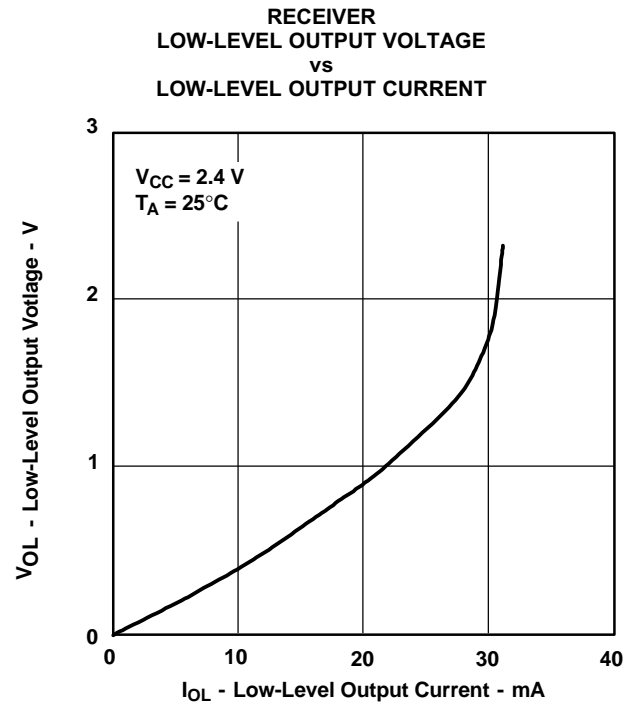
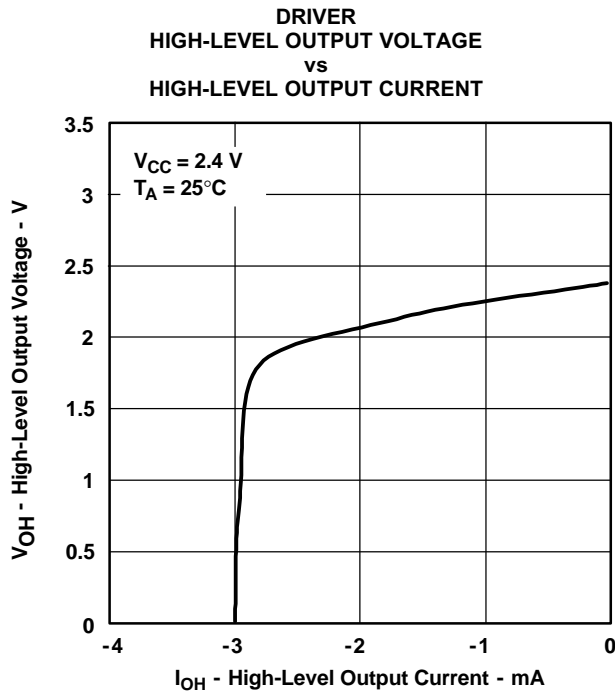
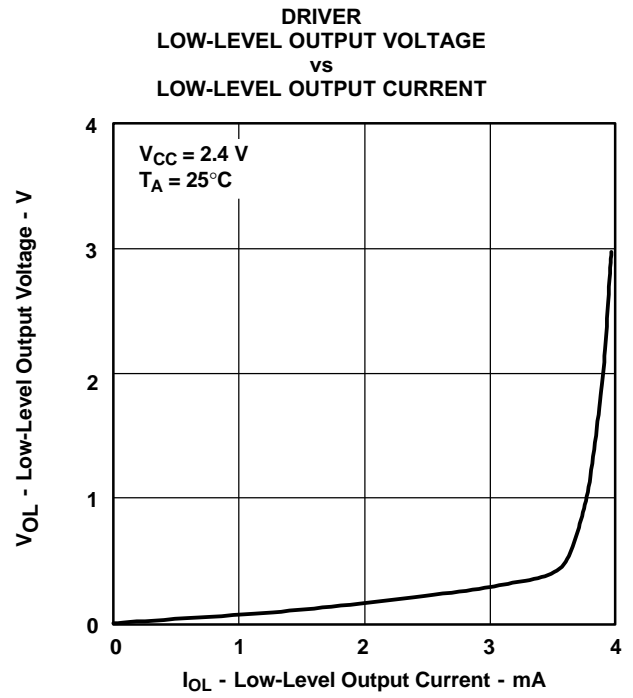
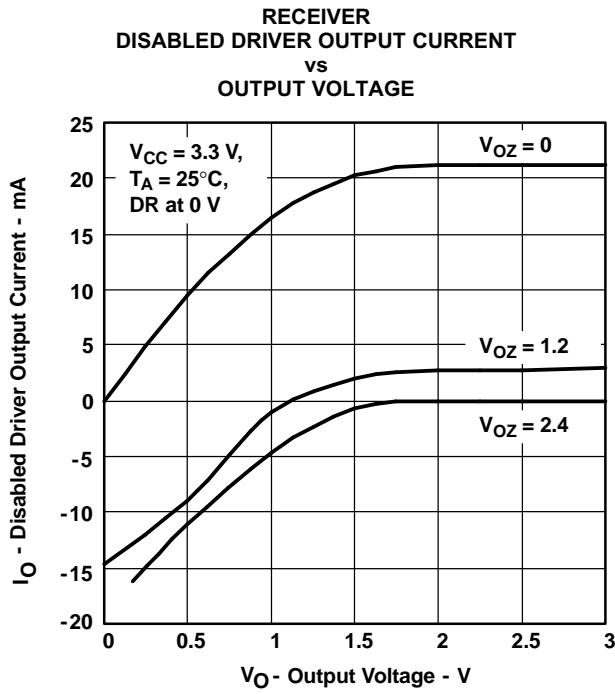
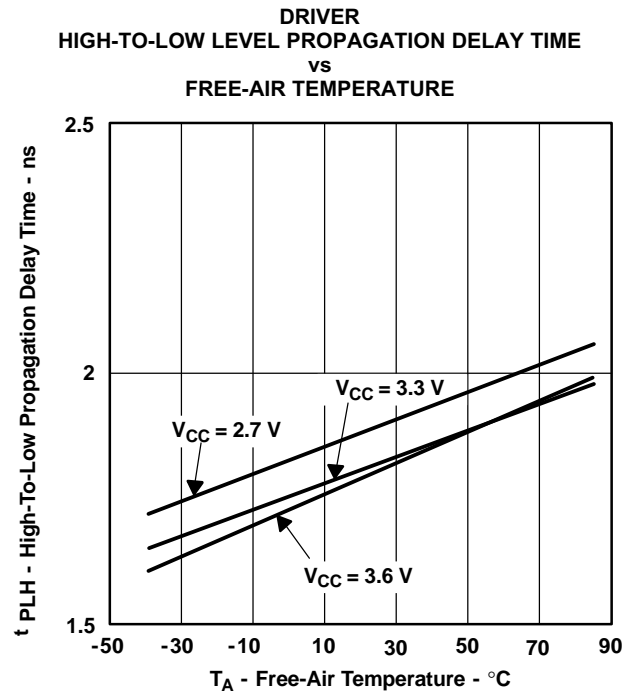
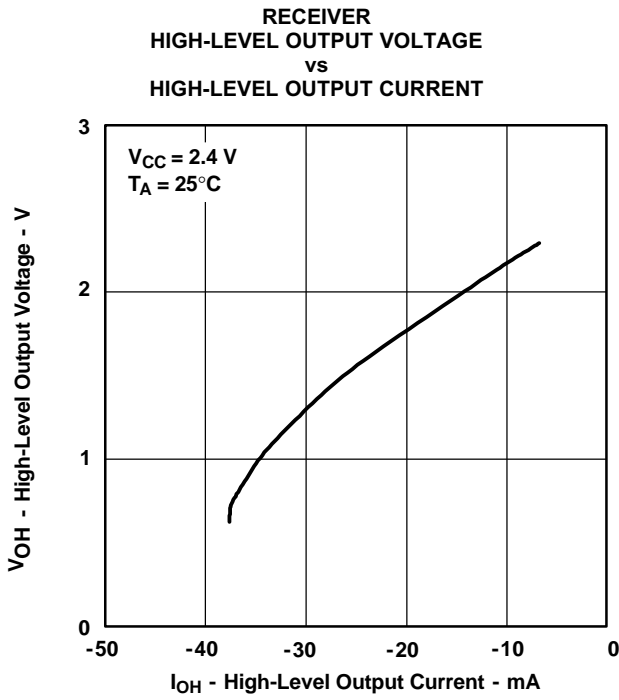

Figure 7. Enable/Disable Time Test Circuit and Waveforms

TYPICAL CHARACTERISTICS





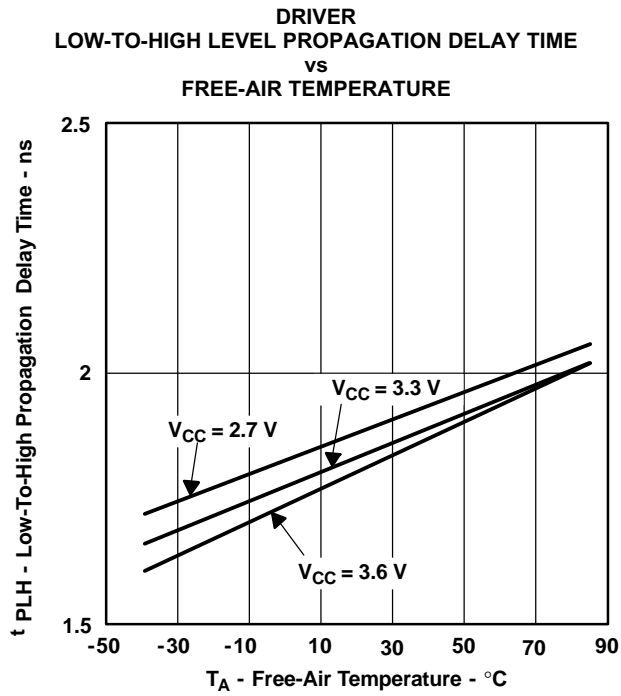

Figure 14.

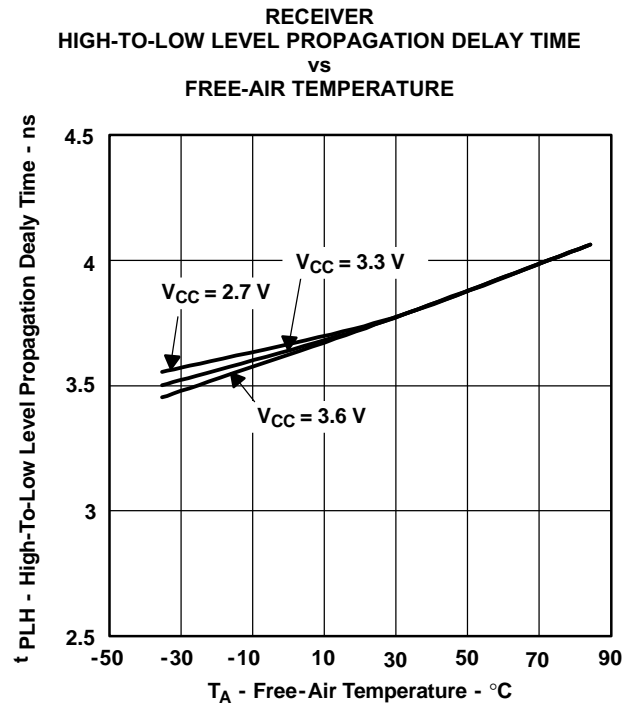

Figure 15.

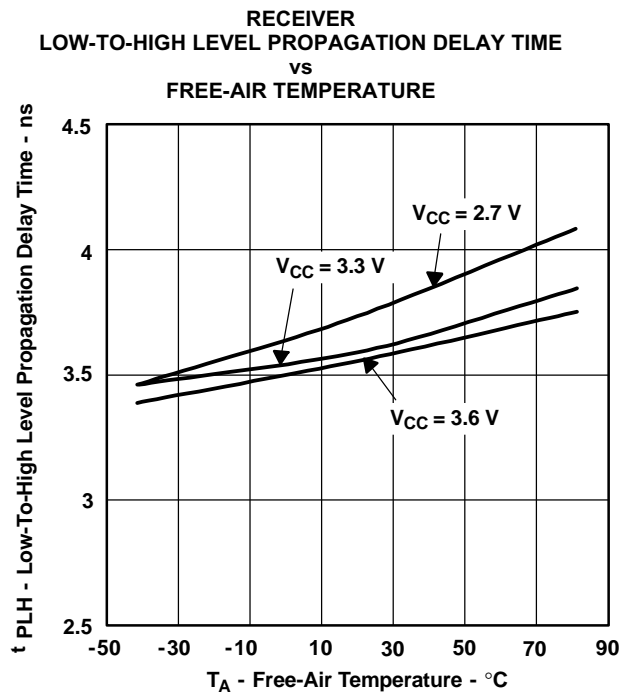

Figure 16

## APPLICATION INFORMATION

The devices are generally used as building blocks for high-speed point-to-point data transmission. Ground differences are less than 1 V with a low common-mode output and balanced interface for very low noise emissions. Devices can interoperate with RS-422, PECL, and IEEE-P1596. Drivers/Receivers maintain ECL speeds without the power and dual supply requirements.

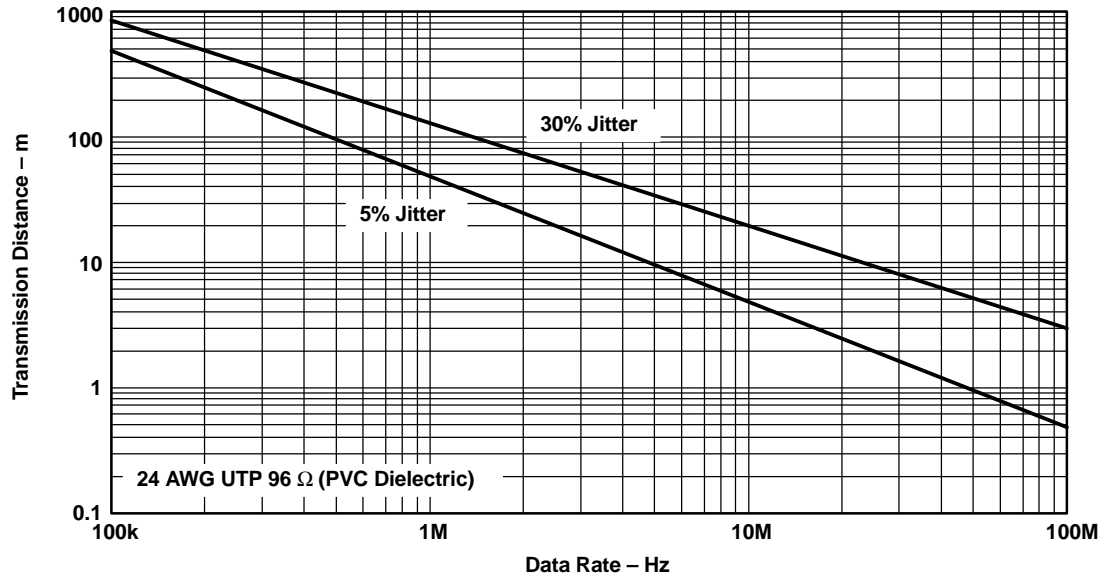
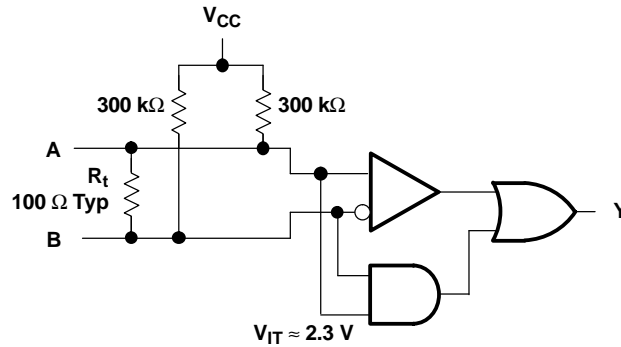

Figure 17. Data Transmission Distance Versus Rate

### Fail Safe

One of the most common problems with differential signaling applications is how the system responds when no differential voltage is present on the signal pair. The LVDS receiver is like most differential line receivers, in that its output logic state can be indeterminate when the differential input voltage is between -100 mV and 100 mV and within its recommended input common-mode voltage range. TI's LVDS receiver is different in how it handles the open-input circuit situation, however.

Open-circuit means that there is little or no input current to the receiver from the data line itself. This could be when the driver is in a high-impedance state or the cable is disconnected. When this occurs, the LVDS receiver pulls each line of the signal pair to near  $V_{CC}$  through 300-k $\Omega$  resistors as shown in Figure 11. The fail-safe feature uses an AND gate with input voltage thresholds at about 2.3 V to detect this condition and force the output to a high-level, regardless of the differential input voltage.



**Figure 18. Open-Circuit Fail Safe of the LVDS Receiver**

It is only under these conditions that the output of the receiver is valid with less than a 100-mV differential input voltage magnitude. The presence of the termination resistor,  $R_t$ , does not affect the fail-safe function as long as it is connected as shown in the figure. Other termination circuits may allow a dc current to ground that could defeat the pullup currents from the receiver and the fail-safe feature.

**PACKAGING INFORMATION**

Orderable part number	Status (1)	Material type (2)	Package   Pins	Package qty   Carrier	RoHS (3)	Lead finish/ Ball material (4)	MSL rating/ Peak reflow (5)	Op temp (°C)	Part marking (6)
<a href="#">SN65LVDS1050PW</a>	Active	Production	TSSOP (PW)   16	90   TUBE	Yes	NIPDAU	Level-1-260C-UNLIM	-40 to 85	DL1050
SN65LVDS1050PW.B	Active	Production	TSSOP (PW)   16	90   TUBE	Yes	NIPDAU	Level-1-260C-UNLIM	-40 to 85	DL1050
SN65LVDS1050PWG4	Active	Production	TSSOP (PW)   16	90   TUBE	Yes	NIPDAU	Level-1-260C-UNLIM	-40 to 85	DL1050
<a href="#">SN65LVDS1050PWR</a>	Active	Production	TSSOP (PW)   16	2000   LARGE T&R	Yes	NIPDAU	Level-1-260C-UNLIM	-40 to 85	DL1050
SN65LVDS1050PWR.B	Active	Production	TSSOP (PW)   16	2000   LARGE T&R	Yes	NIPDAU	Level-1-260C-UNLIM	-40 to 85	DL1050
SN65LVDS1050PWRG4	Active	Production	TSSOP (PW)   16	2000   LARGE T&R	Yes	NIPDAU	Level-1-260C-UNLIM	-40 to 85	DL1050
SN65LVDS1050PWRG4.B	Active	Production	TSSOP (PW)   16	2000   LARGE T&R	Yes	NIPDAU	Level-1-260C-UNLIM	-40 to 85	DL1050

(1) **Status:** For more details on status, see our [product life cycle](#).

(2) **Material type:** When designated, preproduction parts are prototypes/experimental devices, and are not yet approved or released for full production. Testing and final process, including without limitation quality assurance, reliability performance testing, and/or process qualification, may not yet be complete, and this item is subject to further changes or possible discontinuation. If available for ordering, purchases will be subject to an additional waiver at checkout, and are intended for early internal evaluation purposes only. These items are sold without warranties of any kind.

(3) **RoHS values:** Yes, No, RoHS Exempt. See the [TI RoHS Statement](#) for additional information and value definition.

(4) **Lead finish/Ball material:** Parts may have multiple material finish options. Finish options are separated by a vertical ruled line. Lead finish/Ball material values may wrap to two lines if the finish value exceeds the maximum column width.

(5) **MSL rating/Peak reflow:** The moisture sensitivity level ratings and peak solder (reflow) temperatures. In the event that a part has multiple moisture sensitivity ratings, only the lowest level per JEDEC standards is shown. Refer to the shipping label for the actual reflow temperature that will be used to mount the part to the printed circuit board.

(6) **Part marking:** There may be an additional marking, which relates to the logo, the lot trace code information, or the environmental category of the part.

Multiple part markings will be inside parentheses. Only one part marking contained in parentheses and separated by a "-" will appear on a part. If a line is indented then it is a continuation of the previous line and the two combined represent the entire part marking for that device.

**Important Information and Disclaimer:** The information provided on this page represents TI's knowledge and belief as of the date that it is provided. TI bases its knowledge and belief on information provided by third parties, and makes no representation or warranty as to the accuracy of such information. Efforts are underway to better integrate information from third parties. TI has taken and continues to take reasonable steps to provide representative and accurate information but may not have conducted destructive testing or chemical analysis on incoming materials and chemicals. TI and TI suppliers consider certain information to be proprietary, and thus CAS numbers and other limited information may not be available for release.

In no event shall TI's liability arising out of such information exceed the total purchase price of the TI part(s) at issue in this document sold by TI to Customer on an annual basis.



**TAPE AND REEL INFORMATION**

**QUADRANT ASSIGNMENTS FOR PIN 1 ORIENTATION IN TAPE**

\*All dimensions are nominal

Device	Package Type	Package Drawing	Pins	SPQ	Reel Diameter (mm)	Reel Width W1 (mm)	A0 (mm)	B0 (mm)	K0 (mm)	P1 (mm)	W (mm)	Pin1 Quadrant
SN65LVDS1050PWR	TSSOP	PW	16	2000	330.0	12.4	6.9	5.6	1.6	8.0	12.0	Q1
SN65LVDS1050PWRG4	TSSOP	PW	16	2000	330.0	12.4	6.9	5.6	1.6	8.0	12.0	Q1

**TAPE AND REEL BOX DIMENSIONS**

\*All dimensions are nominal

Device	Package Type	Package Drawing	Pins	SPQ	Length (mm)	Width (mm)	Height (mm)
SN65LVDS1050PWR	TSSOP	PW	16	2000	356.0	356.0	35.0
SN65LVDS1050PWRG4	TSSOP	PW	16	2000	356.0	356.0	35.0

**TUBE**

\*All dimensions are nominal

Device	Package Name	Package Type	Pins	SPQ	L (mm)	W (mm)	T (μm)	B (mm)
SN65LVDS1050PW	PW	TSSOP	16	90	530	10.2	3600	3.5
SN65LVDS1050PW.B	PW	TSSOP	16	90	530	10.2	3600	3.5
SN65LVDS1050PWG4	PW	TSSOP	16	90	530	10.2	3600	3.5



4220204/A 02/2017

NOTES:

1. All linear dimensions are in millimeters. Any dimensions in parenthesis are for reference only. Dimensioning and tolerancing per ASME Y14.5M.
2. This drawing is subject to change without notice.
3. This dimension does not include mold flash, protrusions, or gate burrs. Mold flash, protrusions, or gate burrs shall not exceed 0.15 mm per side.
4. This dimension does not include interlead flash. Interlead flash shall not exceed 0.25 mm per side.
5. Reference JEDEC registration MO-153.

# EXAMPLE BOARD LAYOUT

PW0016A

TSSOP - 1.2 mm max height

SMALL OUTLINE PACKAGE



LAND PATTERN EXAMPLE  
EXPOSED METAL SHOWN  
SCALE: 10X



SOLDER MASK DETAILS

4220204/A 02/2017

NOTES: (continued)

- 6. Publication IPC-7351 may have alternate designs.
- 7. Solder mask tolerances between and around signal pads can vary based on board fabrication site.

# EXAMPLE STENCIL DESIGN

PW0016A

TSSOP - 1.2 mm max height

SMALL OUTLINE PACKAGE



SOLDER PASTE EXAMPLE  
BASED ON 0.125 mm THICK STENCIL  
SCALE: 10X

4220204/A 02/2017

NOTES: (continued)

8. Laser cutting apertures with trapezoidal walls and rounded corners may offer better paste release. IPC-7525 may have alternate design recommendations.
9. Board assembly site may have different recommendations for stencil design.

## IMPORTANT NOTICE AND DISCLAIMER

TI PROVIDES TECHNICAL AND RELIABILITY DATA (INCLUDING DATA SHEETS), DESIGN RESOURCES (INCLUDING REFERENCE DESIGNS), APPLICATION OR OTHER DESIGN ADVICE, WEB TOOLS, SAFETY INFORMATION, AND OTHER RESOURCES "AS IS" AND WITH ALL FAULTS, AND DISCLAIMS ALL WARRANTIES, EXPRESS AND IMPLIED, INCLUDING WITHOUT LIMITATION ANY IMPLIED WARRANTIES OF MERCHANTABILITY, FITNESS FOR A PARTICULAR PURPOSE OR NON-INFRINGEMENT OF THIRD PARTY INTELLECTUAL PROPERTY RIGHTS.

These resources are intended for skilled developers designing with TI products. You are solely responsible for (1) selecting the appropriate TI products for your application, (2) designing, validating and testing your application, and (3) ensuring your application meets applicable standards, and any other safety, security, regulatory or other requirements.

These resources are subject to change without notice. TI grants you permission to use these resources only for development of an application that uses the TI products described in the resource. Other reproduction and display of these resources is prohibited. No license is granted to any other TI intellectual property right or to any third party intellectual property right. TI disclaims responsibility for, and you will fully indemnify TI and its representatives against, any claims, damages, costs, losses, and liabilities arising out of your use of these resources.

TI's products are provided subject to [TI's Terms of Sale](#) or other applicable terms available either on [ti.com](https://www.ti.com) or provided in conjunction with such TI products. TI's provision of these resources does not expand or otherwise alter TI's applicable warranties or warranty disclaimers for TI products.

TI objects to and rejects any additional or different terms you may have proposed.

Mailing Address: Texas Instruments, Post Office Box 655303, Dallas, Texas 75265

Copyright © 2025, Texas Instruments Incorporated