

Gigabit 2x2 CROSSPOINT SWITCH

FEATURES

- Up to 4.25 Gbps Operation
- Non-blocking Architecture Allows Each Output to be Connected to Any Input
- 30 ps of Deterministic Jitter
- Selectable Transmit Pre-Emphasis Per Lane
- Receive Equalization
- Available Packaging 24 Pin QFN
- Propagation Delay Times: 500 ps Typical
- Inputs Electrically Compatible With CML Signal Levels
- Operates From a Single 3.3-V Supply
- Ability to 3-STATE Outputs
- Low Power: 290 mW (typ)
- Integrated Termination Resistors

APPLICATIONS

- Clock Buffering/Clock MUXing
- Wireless Base Stations
- High-Speed Network Routing
- Telecom/Datacom
- XAUI 802.3ae Protocol Backplane Redundancy

DESCRIPTION

The SN65LVCP402 is a 2x2 non-blocking crosspoint switch in a flow-through pin-out allowing for ease in PCB layout. VML signaling is used to achieve a high-speed data throughput while using low power. Each of the output drivers includes a 2:1 multiplexer to allow any input to be routed to any output. Internal signal paths are fully differential to achieve the high signaling speeds while maintaining low signal skews. The SN65LVCP402 incorporates 100-Ω termination resistors for those applications where board space is a premium. Built-in transmit pre-emphasis and receive equalization for superior signal integrity performance.

The SN65LVCP402 is characterized for operation from -40°C to 85°C.

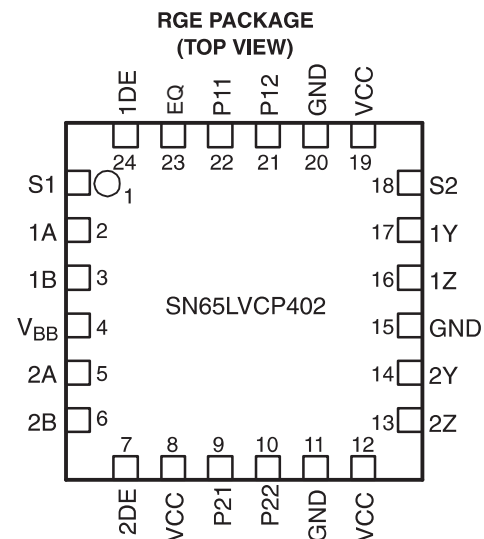

Please be aware that an important notice concerning availability, standard warranty, and use in critical applications of Texas Instruments semiconductor products and disclaimers thereto appears at the end of this data sheet.



These devices have limited built-in ESD protection. The leads should be shorted together or the device placed in conductive foam during storage or handling to prevent electrostatic damage to the MOS gates.

LOGIC DIAGRAM

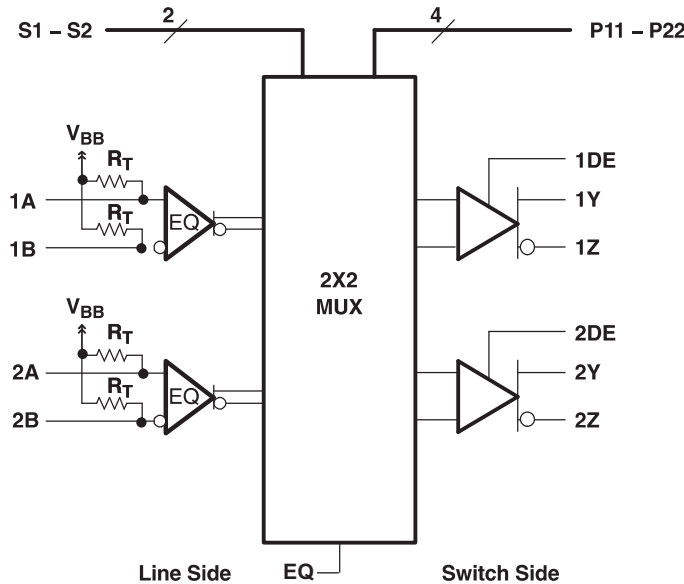

Note:

V_{BB}: Receiver input internal biasing voltage (allows ac coupling)

EQ: Input Equalizer (compensates for frequency dependent transmission line loss of backplanes)

R_T: Internal 50-Ohm receiver termination (100-Ohm differential)

Preemphasis: Output precompensation for transmission line losses

TERMINAL FUNCTIONS

TERMINAL		TYPE	DESCRIPTION
NAME	NO.		
High Speed I/O			
xA xB	2, 5 3, 6	Differential Inputs (with 50-Ω termination to V _{BB}) xA=P; xB=N	Line Side Differential Inputs CML compatible
xY xZ	17, 14 16, 13	Differential Output xY=P; xZ=N	Switch Side Differential Outputs. VML
Control Signals			
x \overline{DE}	24, 7	Input	Data Enable; Active Low; LVTTTL; When not enabled the output is in 3-STATE mode for power savings
S1, S2	1, 18	Input; S1 = Channel 1	Switching Selection; LVTTTL
P11-P22	22, 21, 9, 10	Input; P11- Channel 1 bit one	Output Preemphasis Control; LVTTTL
EQ	23	Input: Selection for Receive Equalization Setting	EQ=1 (default) is for the 5 dB setting; EQ=0 is for the 12 dB setting
Power Supply			
VCC	8, 12, 19	Power	Power Supply 3.3 V ±5%
GND	11, 15, 20		
Thermal Pad	Thermal Pad		The ground center pad of the package must be connected to GND plane with thermal vias.
V _{BB}	4	Input	Receiver input biasing voltage. For ac coupling, V _{BB} should be left floating for optimal bias value. For dc coupling, V _{BB} can be driven to change the common mode. V _{BB} should not be tied to ground.

EQUIVALENT INPUT AND OUTPUT SCHEMATIC DIAGRAMS

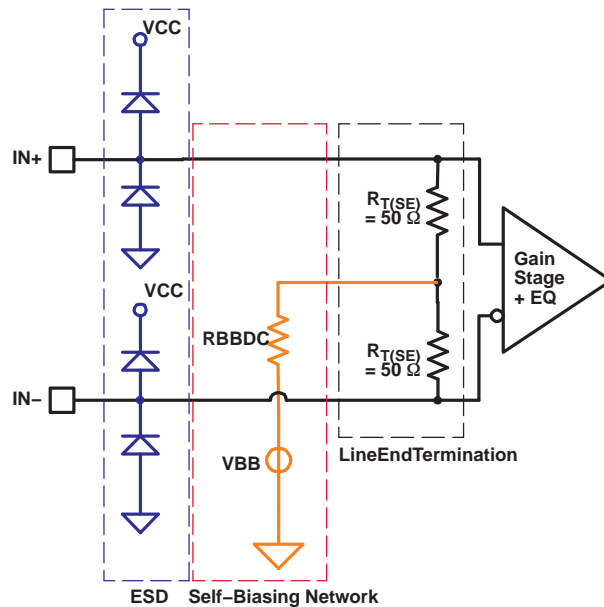

Figure 1. Equivalent Input Circuit Design

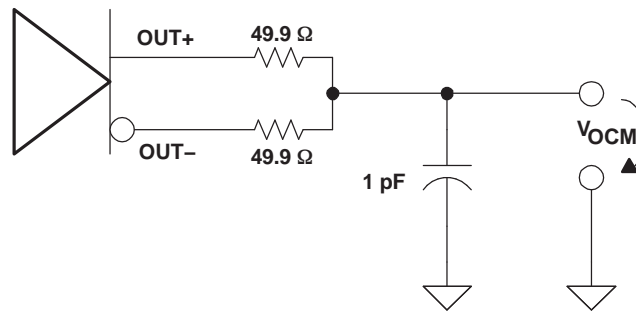

Figure 2. Common-Mode Output Voltage Test Circuit

Table 1. CROSSPOINT LOGIC TABLES

OUTPUT CHANNEL 1 (1Y/1Z)		OUTPUT CHANNEL 2 (2Y/2Z)	
CONTROL PINS	INPUT SELECTED	CONTROL PINS	INPUT SELECTED
S1		S2	
0	1A/1B	0	1A/1B
1	2A/2B	1	2A/2B

AVAILABLE OPTIONS

T _A	DESCRIPTION	PACKAGED DEVICE ⁽¹⁾⁽²⁾
		RGE (24 pin)
-40°C to 85°C	Serial multiplexer	SN65LVCP402

(1) The package is available taped and reeled. Add an R suffix to device types (e.g., SN65LVCP402RGER).

(2) For the most current package and ordering information, see the Package Option Addendum at the end of this document, or see the TI website at www.ti.com.

DISSIPATION RATINGS

PACKAGE THERMAL CHARACTERISTICS ⁽¹⁾		
Parameter	Conditions	NOM
θ_{JA} (junction-to-ambient) #1	4-layer JEDEC Board (JESD51-7), Airflow = 0 ft/min	106.6 C/W
θ_{JA} (junction-to-ambient) #2	4-layer JEDEC Board (JESD51-7) using 4 Thermal-vias of 22-mil diameter each, Airflow = 0 ft/min	55.4 C/W

(1) See application note [SPRA953](http://www-s.ti.com/sc/psheets/spra953/spra953.pdf) for a detailed explanation of thermal parameters (<http://www-s.ti.com/sc/psheets/spra953/spra953.pdf>).

ABSOLUTE MAXIMUM RATINGS

over operating free-air temperature range (unless otherwise noted)⁽¹⁾

		UNIT	
V_{CC}	Supply voltage range ⁽²⁾	–0.5 V to 6 V	
V_I	Voltage range	Control inputs, all outputs	–0.5 V to ($V_{CC} + 0.5$ V)
		Receiver inputs	–0.5 V to 4 V
ESD	Human Body Model ⁽³⁾	All pins	4 kV
	Charged-Device Model ⁽⁴⁾	All pins	500 V
T_J	Maximum junction temperature	See Package Thermal Characteristics Table	
	Moisture sensitivity level	2	
	Reflow temperature package soldering, 4 seconds	260°C	

(1) Stresses beyond those listed under absolute maximum ratings may cause permanent damage to the device. These are stress ratings only and functional operation of the device at these or any other conditions beyond those indicated under recommended operating conditions is not implied. Exposure to absolute-maximum-rated conditions for extended periods may affect device reliability.

(2) All voltage values, except differential I/O bus voltages, are with respect to network ground terminal.

(3) Tested in accordance with JEDEC Standard 22, Test Method A114-A.

(4) Tested in accordance with JEDEC Standard 22, Test Method C101.

RECOMMENDED OPERATING CONDITIONS

		MIN	NOM	MAX	UNIT	
dR	Operating data rate			4.25	Gbps	
V _{CC}	Supply voltage	3.135	3.3	3.465	V	
V _{CC(N)}	Supply voltage noise amplitude	10 Hz to 2 GHz		20	mV	
T _J	Junction temperature			125	°C	
T _A	Operating free-air temperature ⁽¹⁾	-40		85	°C	
DIFFERENTIAL INPUTS						
V _{ID}	Receiver peak-to-peak differential input voltage ⁽²⁾	dR _(in) ≤ 1.25 Gbps		100	1750	mV _{PP}
		1.25 Gbps < dR _(in) ≤ 3.125 Gbps		100	1560	mV _{PP}
		dR _(in) > 3.125 Gbps		100	1000	mV _{PP}
V _{ICM}	Receiver common-mode input voltage	Note: for best jitter performance ac coupling is recommended.		1.5	1.6 V _{CC} - $\frac{ V_{ID} }{2}$	V
CONTROL INPUTS						
V _{IH}	High-level input voltage	2		V _{CC} + 0.3	V	
V _{IL}	Low-level input voltage	-0.3		0.8	V	
DIFFERENTIAL OUTPUTS						
R _L	Differential load resistance	80	100	120	Ω	

(1) Maximum free-air temperature operation is allowed as long as the device maximum junction temperature is not exceeded.

(2) Differential input voltage V_{ID} is defined as |IN+ – IN–|.

ELECTRICAL CHARACTERISTICS

over operating free-air temperature range (unless otherwise noted)

PARAMETER	TEST CONDITIONS	MIN	TYP ⁽¹⁾	MAX	UNIT
DIFFERENTIAL INPUTS					
V _{IT+}	Positive going differential input high threshold			50	mV
V _{IT–}	Negative going differential input low threshold	-50			mV
A _(EQ)	Equalizer gain	at 1.875 GHz (EQ=0)		12	dB
R _{T(D)}	Termination resistance, differential	80	100	120	Ω
V _{BB}	Open-circuit Input voltage (input self-bias voltage)	AC-coupled inputs		1.6	V
R _(BBDC)	Biasing network dc impedance		30		kΩ
R _(BBAC)	Biasing network ac impedance	375 MHz	42		Ω
		1.875 GHz	8.4		
DIFFERENTIAL OUTPUTS					
V _{ODH}	High-level output voltage	R _L = 100 Ω ±1%, PRES_1 = PRES_0=0; PREL_1 = PREL_0=0; 4 Gbps alternating 1010-pattern; Figure 3		650	mV _{PP}
V _{ODL}	Low-level output voltage			-650	mV _{PP}
V _{ODB(PP)}	Output differential voltage without preemphasis ⁽²⁾	1000	1300	1500	mV _{PP}
V _{OCM}	Output common mode voltage		1.65		V
ΔV _{OC(SS)}	Change in steady-state common-mode output voltage between logic states	See Figure 2		1	mV

(1) All typical values are at T_A = 25°C and V_{CC} = 3.3 V supply unless otherwise noted. They are for reference purposes and are not production tested.

(2) Differential output voltage V_(ODB) is defined as |OUT+ – OUT–|.

ELECTRICAL CHARACTERISTICS (continued)

over operating free-air temperature range (unless otherwise noted)

PARAMETER		TEST CONDITIONS	MIN	TYP ⁽¹⁾	MAX	UNIT
$V_{(PE)}$	Output preemphasis voltage ratio, $\frac{V_{ODB(PP)}}{V_{ODPE(PP)}}$	$R_L = 100 \Omega \pm 1\%$; $x = \text{Channel 1 or 2}$; See Figure 3				dB
		$Px_2:Px_1 = 00$		0		
		$Px_2:Px_1 = 01$		3		
		$Px_2:Px_1 = 10$		6		
		$Px_2:Px_1 = 11$		9		
$t_{(PRE)}$	Preemphasis duration measurement	Output preemphasis is set to 9 dB during test $PREx_x = 1$; Measured with a 100-MHz clock signal; $R_L = 100 \Omega \pm 1\%$, See Figure 4		175		ps
r_o	Output resistance	Differential on-chip termination between OUT+ and OUT–		100		Ω
CONTROL INPUTS						
I_{IH}	High-level Input current	$V_{IN} = V_{CC}$			5	μA
I_{IL}	Low-level Input current	$V_{IN} = GND$	-125	-90		μA
$R_{(PU)}$	Pullup resistance			35		k Ω
POWER CONSUMPTION						
P_D	Device power dissipation	All outputs terminated 100 Ω		290	414	mW
P_Z	Device power dissipation in 3-state	All outputs in 3-state			331	mW
I_{CC}	Device current consumption	All outputs terminated 100 Ω			115	mA
		PRBS 2 ⁷⁻¹ pattern at 4 Gbps				

SWITCHING CHARACTERISTICS

over operating free-air temperature range (unless otherwise noted)

PARAMETER		TEST CONDITIONS	MIN	TYP ⁽¹⁾	MAX	UNIT
MULTIPLEXER						
$t_{(SM)}$	Multiplexer switch time	Multiplexer to valid output		3	6	ns
DIFFERENTIAL OUTPUTS						
t_{PLH}	Low-to-high propagation delay	Propagation delay input to output See Figure 6		0.5	0.7	ns
t_{PHL}	High-to-low propagation delay			0.5	0.7	ns
t_r	Rise time	20% to 80% of $V_{O(DB)}$; Test Pattern: 100-MHz clock signal; See Figure 5 and Figure 8		80		ps
t_f	Fall time			80		ps
$t_{sk(p)}$	Pulse skew, $ t_{PHL} - t_{PLH} $ ⁽²⁾				20	ps
$t_{sk(o)}$	Output skew ⁽³⁾	All outputs terminated with 100 Ω		25	100	ps
$t_{sk(pp)}$	Part-to-part skew ⁽⁴⁾				300	ps
t_{zd}	3-State switch time to disable	Assumes 50 Ω to V_{cm} and 150 pF load on each output			20	ns
t_{ze}	3-State switch time to enable	Assumes 50 Ω to V_{cm} and 150 pF load on each output			10	ns
RJ	Device random jitter, rms	See Figure 8 for test circuit. BERT setting 10 ⁻¹⁵ Alternating 10-pattern.		0.8	2	ps-rms

(1) All typical values are at 25°C and with 3.3 V supply unless otherwise noted.

(2) $t_{sk(p)}$ is the magnitude of the time difference between the t_{PLH} and t_{PHL} of any output of a single device.(3) $t_{sk(o)}$ is the magnitude of the time difference between the t_{PLH} and t_{PHL} of any two outputs of a single device.(4) $t_{sk(pp)}$ is the magnitude of the difference in propagation delay times between any specified terminals of two devices when both devices operate with the same supply voltages, at the same temperature, and have identical packages and test circuits.

SWITCHING CHARACTERISTICS (continued)

over operating free-air temperature range (unless otherwise noted)

PARAMETER		TEST CONDITIONS			MIN	TYP ⁽¹⁾	MAX	UNIT
DJ	Intrinsic deterministic device jitter ⁽⁵⁾⁽⁶⁾ , peak-to-peak	0 dB preemphasis (PRE _x = 0); See Figure 8 for the test circuit.	PRBS 2 ⁷⁻¹ pattern	4 Gbps			30	ps
	Absolute deterministic output jitter ⁽⁷⁾ , peak-to-peak	0 dB preemphasis (PRE _x = 0); See Figure 8 for the test circuit.	PRBS 2 ⁷⁻¹ pattern	1.25 Gbps Over 20-inch FR4 trace		7		ps
		4 Gbps Over FR4 trace 2-inch to 20 inches long			20			

- (5) Intrinsic deterministic device jitter is a measurement of the deterministic jitter contribution from the device. It is derived by the equation $(DJ_{(OUT)} - DJ_{(IN)})$, where $DJ_{(OUT)}$ is the total peak-to-peak deterministic jitter measured at the output of the device in PSPP. $DJ_{(IN)}$ is the peak-to-peak deterministic jitter of the pattern generator driving the device.
- (6) The SN65LVCP402 built-in passive input equalizer compensates for ISI. For a 20-inch FR4 transmission line with 8-mil trace width, the LVCP402 typically reduces jitter by 60 ps from the device input to the device output.
- (7) Absolute deterministic output jitter reflects the deterministic jitter measured at the SN65LVCP402 output. The value is a real measured value with a Bit error tester as described in Figure 8. The absolute DJ reflects the sum of all deterministic jitter components accumulated over the link: $DJ_{(absolute)} = DJ_{(Signal\ generator)} + DJ_{(transmission\ line)} + DJ_{(intrinsic(LVCP402))}$.

Table 2. Preemphasis Controls Settings

Px ₂ ⁽¹⁾	Px ₁ ⁽¹⁾	OUTPUT PREEMPHASIS LEVEL IN dB	OUTPUT LEVEL IN mV _{pp}		TYPICAL FR4 TRACE LENGTH
			DE-EMPHASIZED	PRE-EMPHASIZED	
0	0	0 dB	1200	1200	10 inches of FR4 trace
0	1	3 dB	850	1200	20 inches of FR4 trace
1	0	6 dB	600	1200	30 inches of FR4 trace
1	1	9 dB	425	1200	40 inches of FR4 trace

(1) x = 1 or 2

Table 2. Receive Equalization Settings

EQ	Equalization	Typical Line Trace
1	5 dB	25 inches of FR4
0	12 dB	43 inches of FR4

PARAMETER MEASUREMENT INFORMATION

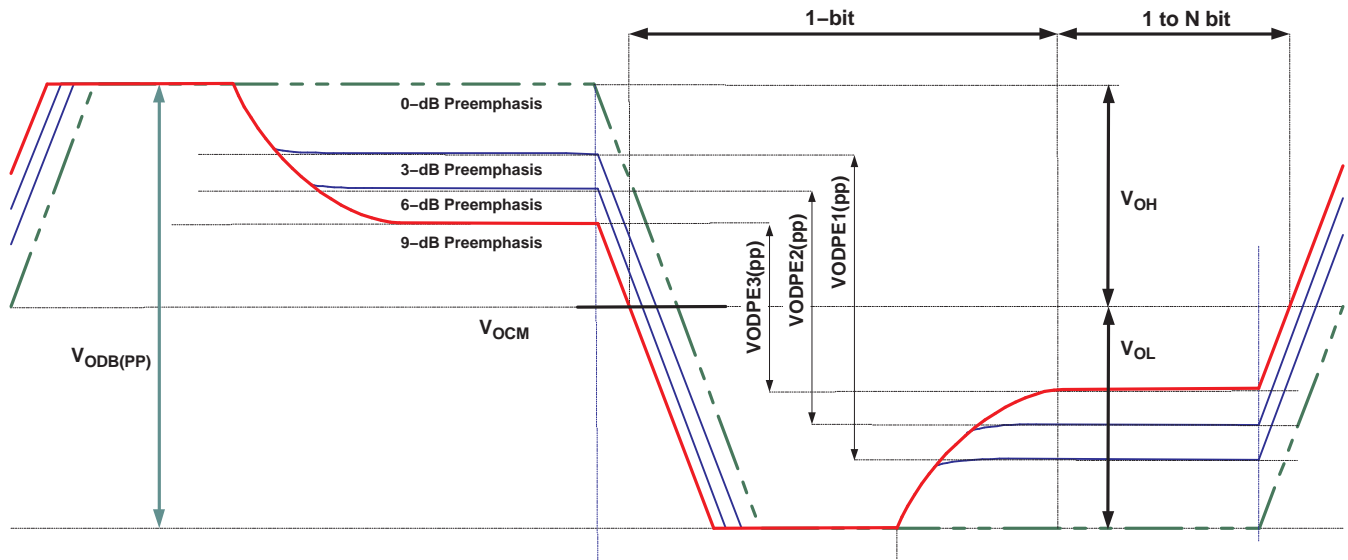

Figure 3. Preemphasis and Output Voltage Waveforms and Definitions

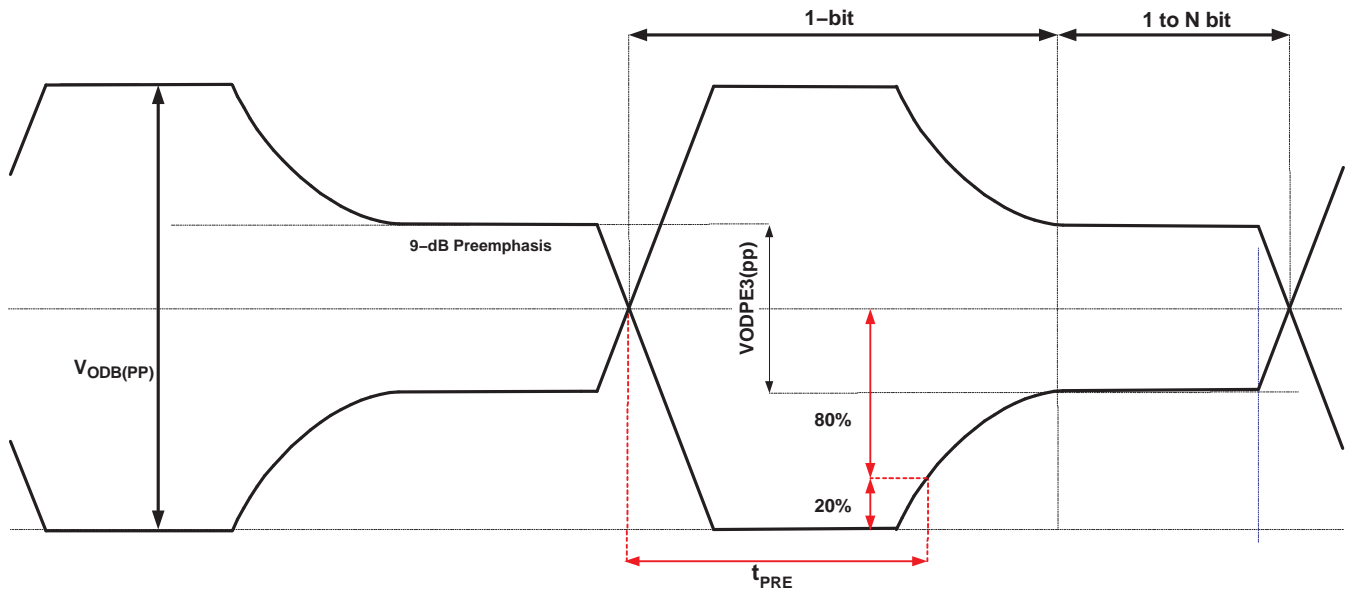

Figure 4. t_{PRE} Preemphasis Duration Measurement

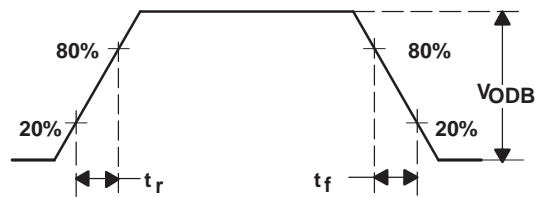

Figure 5. Driver Output Transition Time

PARAMETER MEASUREMENT INFORMATION (continued)

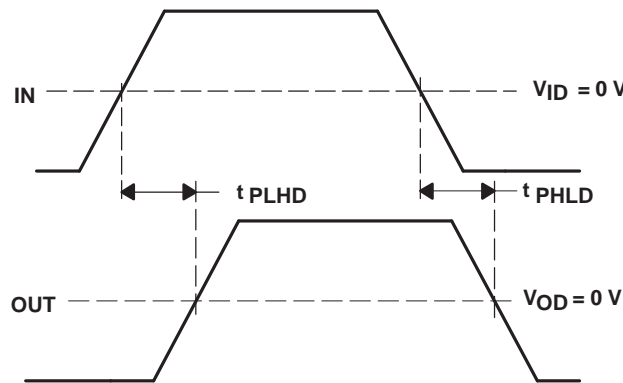
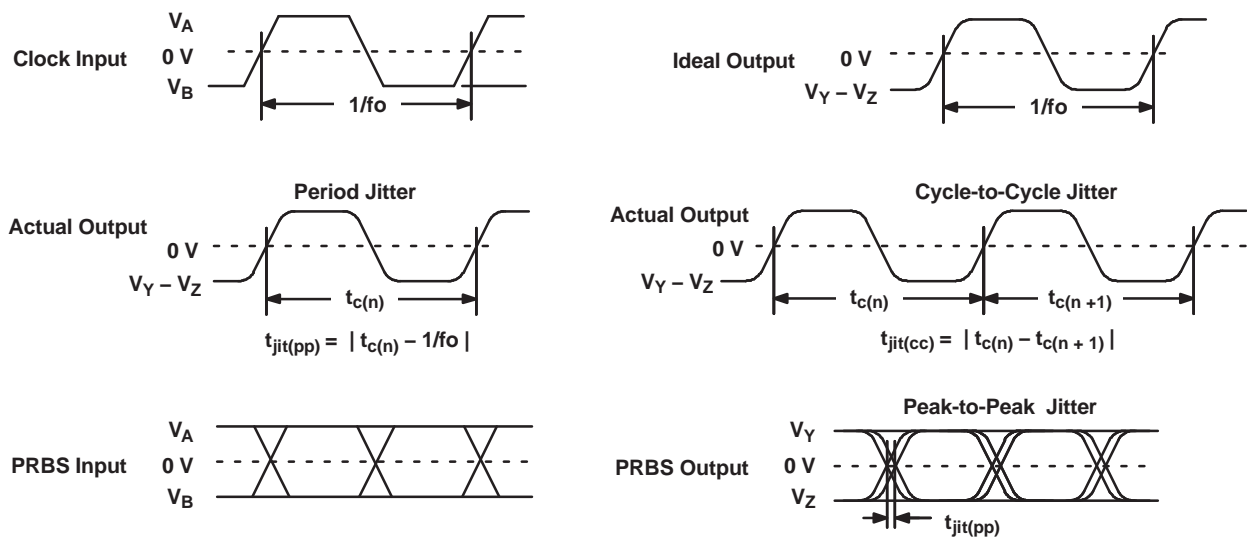

Figure 6. Propagation Delay Input to Output



- A. All input pulses are supplied by an Agilent 81250 Stimulus System.
- B. The measurement is made on a TEK TDS6604 running TDSJIT3 application software.

Figure 7. Driver Jitter Measurement Waveforms

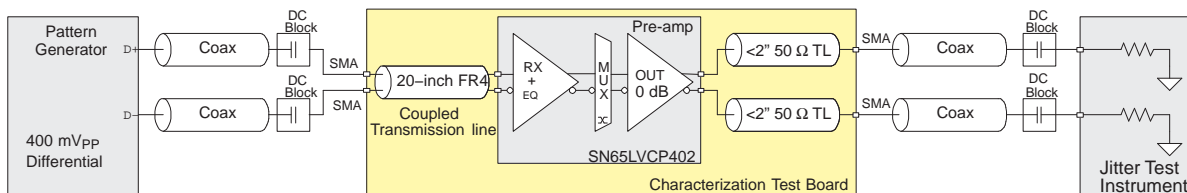
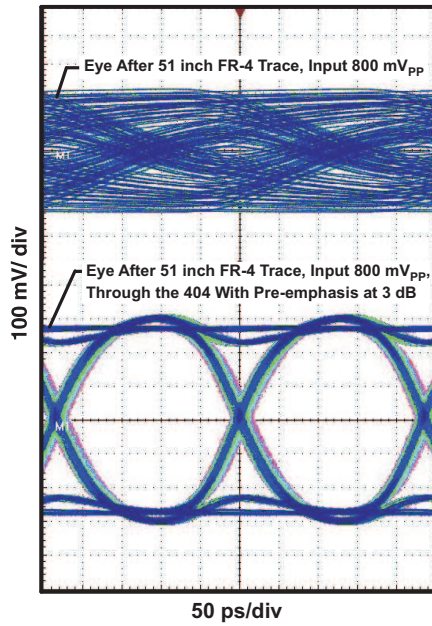

Figure 8. AC Test Circuit — Jitter and Output Rise Time Test Circuit

The SN65LVCP402 input equalizer provides 5-dB frequency gain to compensate for frequency loss of a shorter backplane transmission line. For characterization purposes, a 24-inch FR-4 coupled transmission line is used in place of the backplane trace. The 24-inch trace provides roughly 5 dB of attenuation between 375 MHz and 1.875 GHz, representing closely the characteristics of a short backplane trace. The loss tangent of the FR4 in the test board is 0.018 with an effective $\epsilon(r)$ of 3.1.

TYPICAL DEVICE BEHAVIOR



NOTE: 51 Inch (128.54 cm) Input Trace, dR = 4.25 Gbps; 2^{7-1} PRBS
 Figure 9. Data Input and Output Pattern

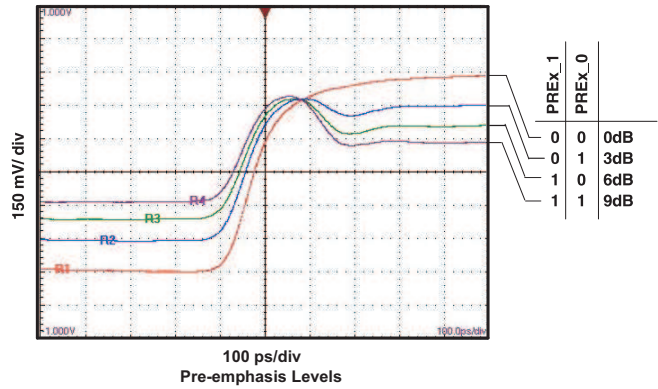

Figure 10. Preemphasis Signal Shape

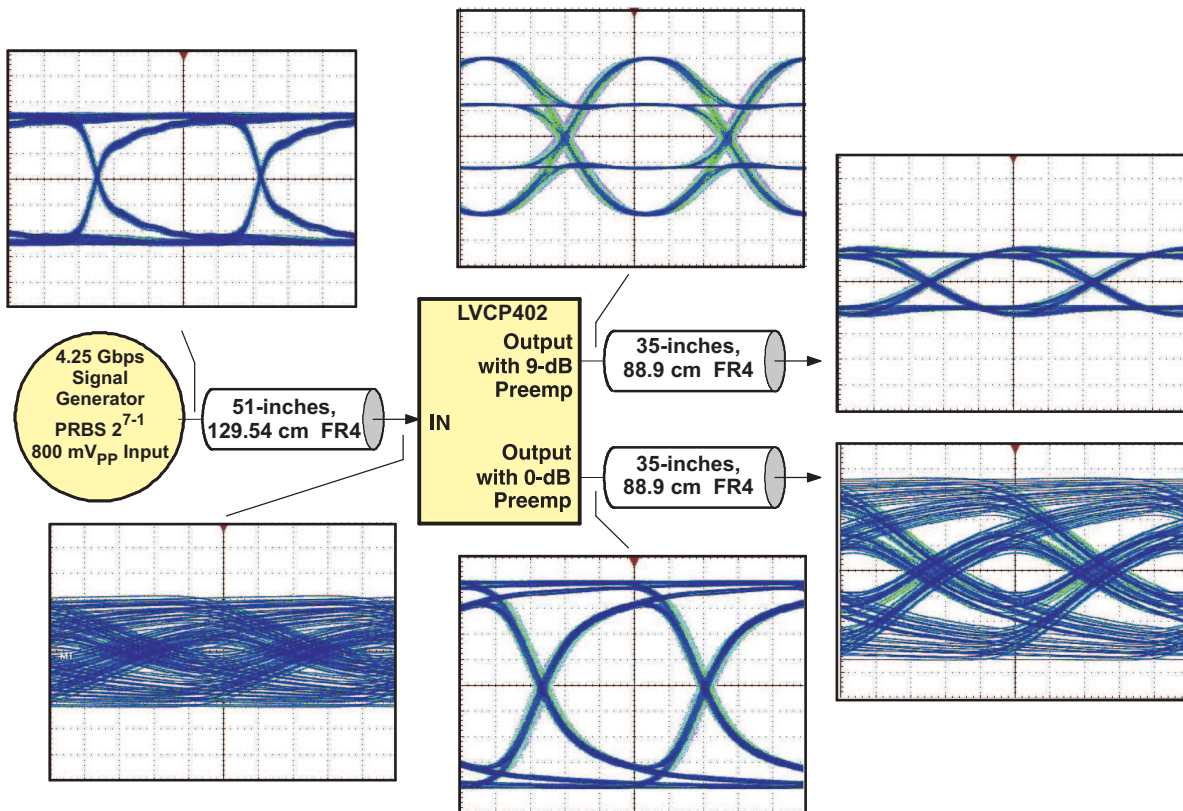

Figure 11. Data Output Pattern

TYPICAL CHARACTERISTICS

DETERMINISTIC OUTPUT JITTER vs DATA RATE

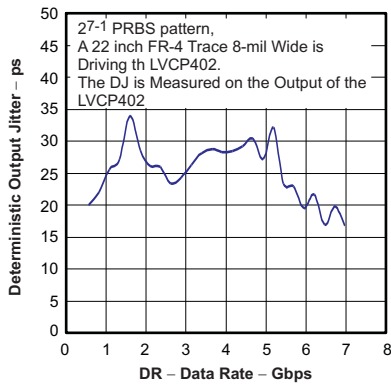

Figure 12.

DETERMINISTIC OUTPUT JITTER vs DIFFERENTIAL INPUT AMPLITUDE

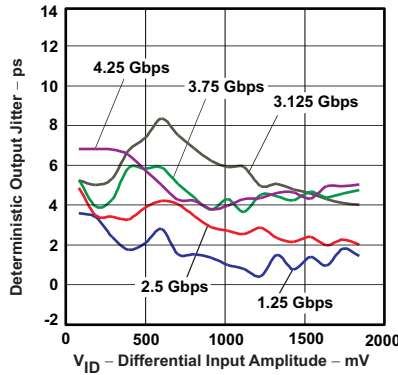

Figure 13.

DIFFERENTIAL OUTPUT VOLTAGE vs DATA RATE

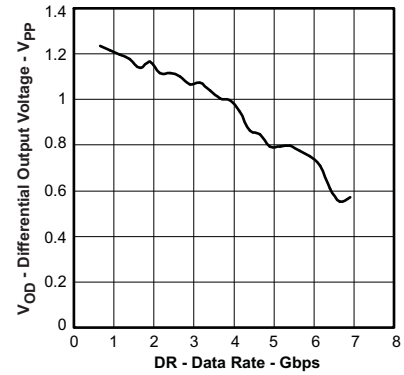

Figure 14.

SUPPLY NOISE vs DETERMINISTIC JITTER vs DATA RATE

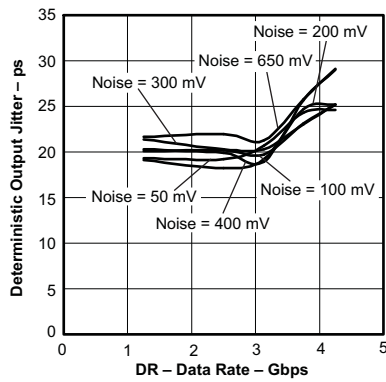

Figure 15.

DETERMINISTIC OUTPUT JITTER vs COMMON-MODE INPUT VOLTAGE

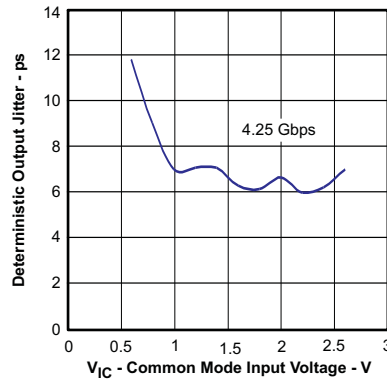

Figure 16.

APPLICATION INFORMATION

BANDWIDTH REQUIREMENTS

Error free transmission of data over a transmission line has specific bandwidth demands. It is helpful to analyze the frequency spectrum of the transmit data first. For an 8B10B coded data stream at 3.75 Gbps of random data, the highest bit transition density occurs with a 1010 pattern (1.875 GHz). The least transition density in 8B10B allows for five consecutive ones or zeros. Hence, the lowest frequency of interest is $1.875 \text{ GHz}/5 = 375 \text{ MHz}$. Real data signals consist of higher frequency components than sine waves due to the fast rise time. The faster the rise time, the more bandwidth becomes required. For 80-ps rise time, the highest important frequency component is at least $0.6/(\pi \times 80 \text{ ps}) = 2.4 \text{ GHz}$. Figure 17 shows the Fourier transformation of the 375-MHz and 1.875-GHz trapezoidal signal.

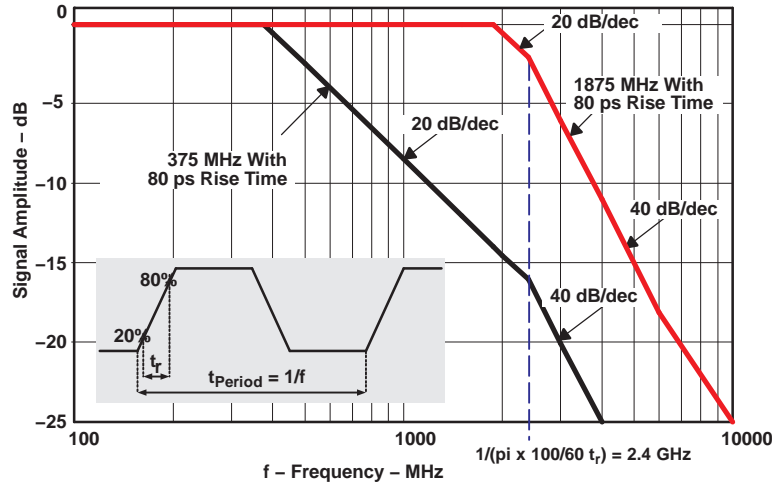

Figure 17. Approximate Frequency Spectrum of the Transmit Output Signal With 80 ps Rise Time

The spectrum analysis of the data signal suggests building a backplane with little frequency attenuation up to 2 GHz. Practically, this is achievable only with expensive, specialized PCB material. To support material like FR4, a compensation technique is necessary to compensate for backplane imperfections.

EXPLANATION OF EQUALIZATION

Backplane designs differ widely in size, layer stack-up, and connector placement. In addition, the performance is impacted by trace architecture (trace width, coupling method) and isolation from adjacent signals. Common to most commercial backplanes is the use of FR4 as board material and its related high-frequency signal attenuation. Within a backplane, the shortest to longest trace lengths differ substantially – often ranging from 8 inches up to 40 inches. Increased loss is associated with longer signal traces. In addition, the backplane connector often contributes a good amount of signal attenuation. As a result, the frequency signal attenuation for a 300-MHz signal might range from 1 dB to 4 dB while the corresponding attenuation for a 2-GHz signal might span 6 dB to 24 dB. This frequency dependent loss causes distortion jitter on the transmitted signal. Each LVCP402 receiver input incorporates an equalizer and compensates for such frequency loss. The SN65LVCP402 equalizer provides 5/12 dB of frequency gain between 375 MHz and 1.875 GHz, compensating roughly for 20 inches of FR4 material with 8-mil trace width. Distortion jitter improvement is substantial, often providing more than 30-ps jitter reduction. The 5-dB compensation is sufficient for most short backplane traces. For longer trace lengths, it is recommended to enable transmit preemphasis in addition.

SETTING THE PREAMPHASIS LEVEL

The receive equalization compensates for ISI. This reduces jitter and opens the data eye. In order to find the best preemphasis setting for each link, calibration of every link is recommended. Assuming each link consists of a transmitter (with adjustable pre-emphasis such as LVCP402) and the LVCP402 receiver, the following steps are necessary:

1. Set the transmitter and receiver to 0-dB preemphasis; record the data eye on the LVCP402 receiver output.
2. Increase the transmitter preemphasis until the data eye on the LVCP402 receiver output looks the cleanest.

PACKAGING INFORMATION

Orderable part number	Status (1)	Material type (2)	Package Pins	Package qty Carrier	RoHS (3)	Lead finish/ Ball material (4)	MSL rating/ Peak reflow (5)	Op temp (°C)	Part marking (6)
SN65LVCP402RGER	Active	Production	VQFN (RGE) 24	3000 LARGE T&R	Yes	NIPDAU	Level-3-260C-168 HR	-40 to 85	LVCP402
SN65LVCP402RGER.B	Active	Production	VQFN (RGE) 24	3000 LARGE T&R	Yes	NIPDAU	Level-3-260C-168 HR	-40 to 85	LVCP402
SN65LVCP402RGERG4	Active	Production	VQFN (RGE) 24	3000 LARGE T&R	Yes	NIPDAU	Level-3-260C-168 HR	-40 to 85	LVCP402
SN65LVCP402RGERG4.B	Active	Production	VQFN (RGE) 24	3000 LARGE T&R	Yes	NIPDAU	Level-3-260C-168 HR	-40 to 85	LVCP402
SN65LVCP402RGET	Active	Production	VQFN (RGE) 24	250 SMALL T&R	Yes	NIPDAU	Level-3-260C-168 HR	-40 to 85	LVCP402
SN65LVCP402RGET.B	Active	Production	VQFN (RGE) 24	250 SMALL T&R	Yes	NIPDAU	Level-3-260C-168 HR	-40 to 85	LVCP402

(1) **Status:** For more details on status, see our [product life cycle](#).

(2) **Material type:** When designated, preproduction parts are prototypes/experimental devices, and are not yet approved or released for full production. Testing and final process, including without limitation quality assurance, reliability performance testing, and/or process qualification, may not yet be complete, and this item is subject to further changes or possible discontinuation. If available for ordering, purchases will be subject to an additional waiver at checkout, and are intended for early internal evaluation purposes only. These items are sold without warranties of any kind.

(3) **RoHS values:** Yes, No, RoHS Exempt. See the [TI RoHS Statement](#) for additional information and value definition.

(4) **Lead finish/Ball material:** Parts may have multiple material finish options. Finish options are separated by a vertical ruled line. Lead finish/Ball material values may wrap to two lines if the finish value exceeds the maximum column width.

(5) **MSL rating/Peak reflow:** The moisture sensitivity level ratings and peak solder (reflow) temperatures. In the event that a part has multiple moisture sensitivity ratings, only the lowest level per JEDEC standards is shown. Refer to the shipping label for the actual reflow temperature that will be used to mount the part to the printed circuit board.

(6) **Part marking:** There may be an additional marking, which relates to the logo, the lot trace code information, or the environmental category of the part.

Multiple part markings will be inside parentheses. Only one part marking contained in parentheses and separated by a "~" will appear on a part. If a line is indented then it is a continuation of the previous line and the two combined represent the entire part marking for that device.

Important Information and Disclaimer: The information provided on this page represents TI's knowledge and belief as of the date that it is provided. TI bases its knowledge and belief on information provided by third parties, and makes no representation or warranty as to the accuracy of such information. Efforts are underway to better integrate information from third parties. TI has taken and continues to take reasonable steps to provide representative and accurate information but may not have conducted destructive testing or chemical analysis on incoming materials and chemicals. TI and TI suppliers consider certain information to be proprietary, and thus CAS numbers and other limited information may not be available for release.

In no event shall TI's liability arising out of such information exceed the total purchase price of the TI part(s) at issue in this document sold by TI to Customer on an annual basis.

TAPE AND REEL INFORMATION

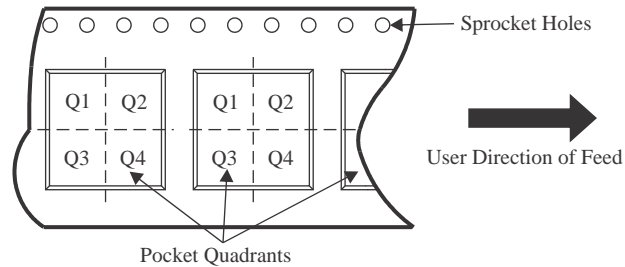
QUADRANT ASSIGNMENTS FOR PIN 1 ORIENTATION IN TAPE

*All dimensions are nominal

Device	Package Type	Package Drawing	Pins	SPQ	Reel Diameter (mm)	Reel Width W1 (mm)	A0 (mm)	B0 (mm)	K0 (mm)	P1 (mm)	W (mm)	Pin1 Quadrant
SN65LVCP402RGER	VQFN	RGE	24	3000	330.0	12.4	4.25	4.25	1.15	8.0	12.0	Q2
SN65LVCP402RGERG4	VQFN	RGE	24	3000	330.0	12.4	4.25	4.25	1.15	8.0	12.0	Q2
SN65LVCP402RGET	VQFN	RGE	24	250	180.0	12.4	4.25	4.25	1.15	8.0	12.0	Q2

TAPE AND REEL BOX DIMENSIONS

*All dimensions are nominal

Device	Package Type	Package Drawing	Pins	SPQ	Length (mm)	Width (mm)	Height (mm)
SN65LVCP402RGER	VQFN	RGE	24	3000	356.0	356.0	35.0
SN65LVCP402RGERG4	VQFN	RGE	24	3000	356.0	356.0	35.0
SN65LVCP402RGET	VQFN	RGE	24	250	213.0	191.0	35.0

GENERIC PACKAGE VIEW

RGE 24

VQFN - 1 mm max height

PLASTIC QUAD FLATPACK - NO LEAD

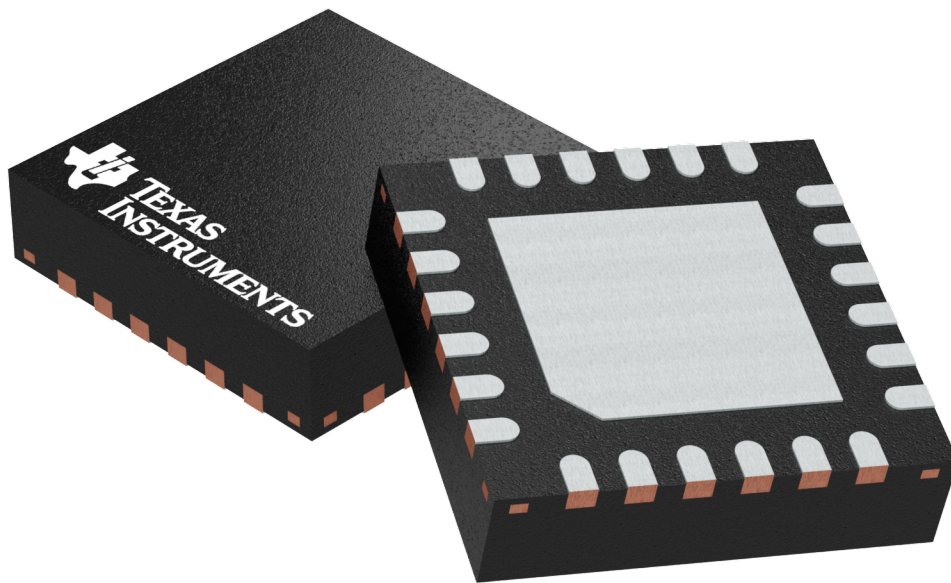

Images above are just a representation of the package family, actual package may vary.
Refer to the product data sheet for package details.

4204104/H

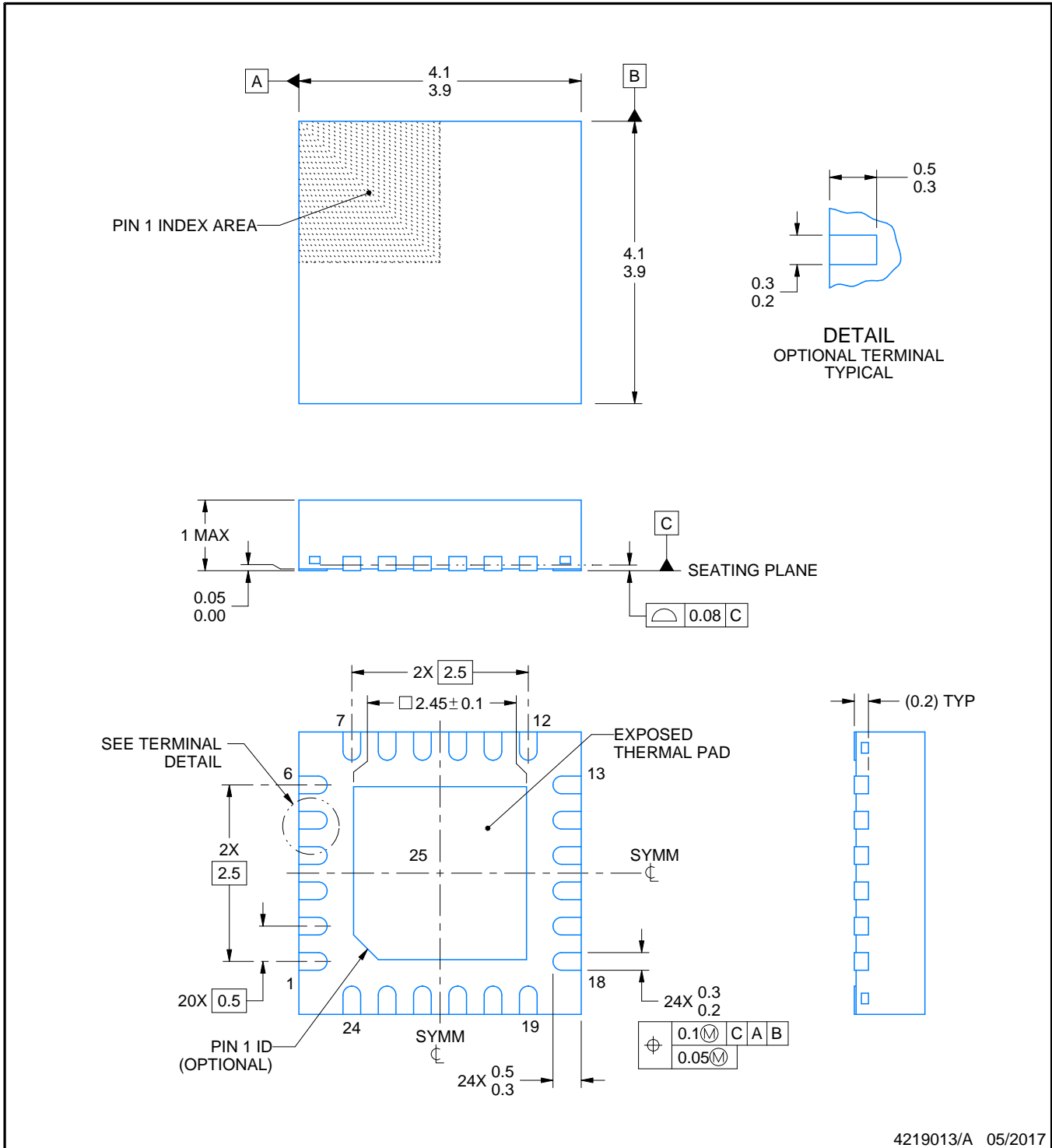
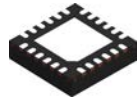

4219013/A 05/2017

NOTES:

1. All linear dimensions are in millimeters. Any dimensions in parenthesis are for reference only. Dimensioning and tolerancing per ASME Y14.5M.
2. This drawing is subject to change without notice.
3. The package thermal pad must be soldered to the printed circuit board for thermal and mechanical performance.

EXAMPLE STENCIL DESIGN

RGE0024B

VQFN - 1 mm max height

PLASTIC QUAD FLATPACK - NO LEAD

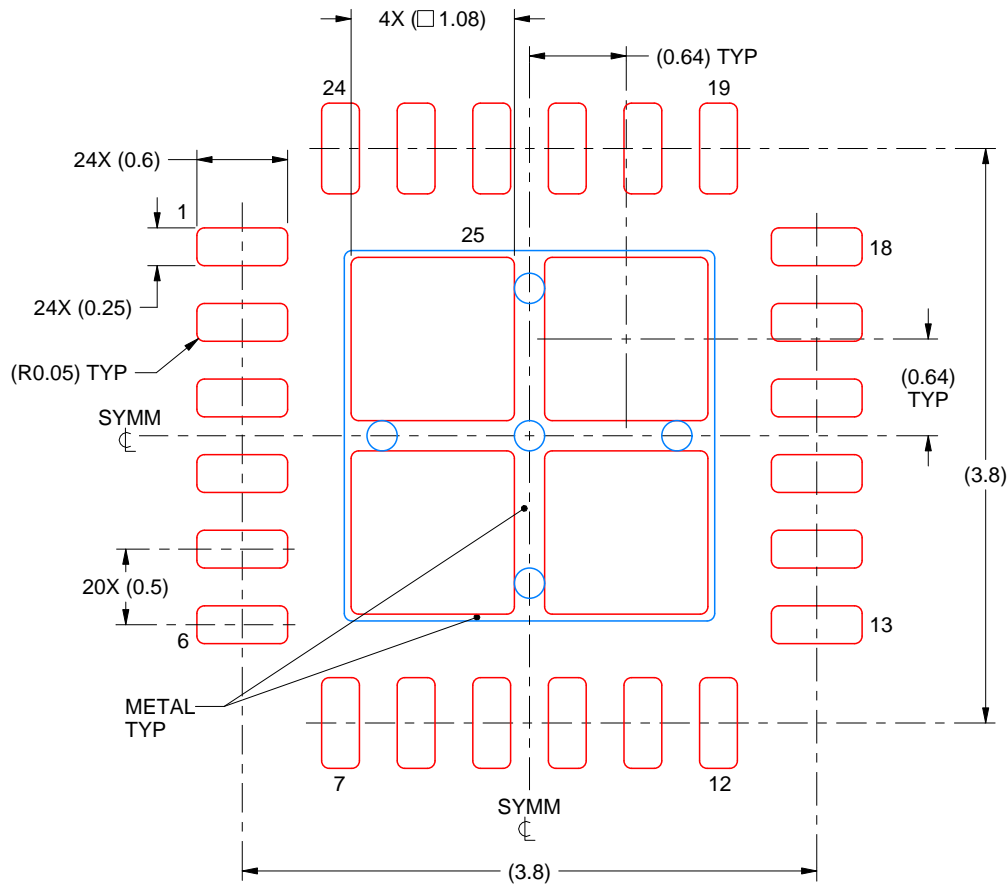

SOLDER PASTE EXAMPLE
 BASED ON 0.125 mm THICK STENCIL

EXPOSED PAD 25
 78% PRINTED SOLDER COVERAGE BY AREA UNDER PACKAGE
 SCALE:20X

4219013/A 05/2017

NOTES: (continued)

6. Laser cutting apertures with trapezoidal walls and rounded corners may offer better paste release. IPC-7525 may have alternate design recommendations.

IMPORTANT NOTICE AND DISCLAIMER

TI PROVIDES TECHNICAL AND RELIABILITY DATA (INCLUDING DATA SHEETS), DESIGN RESOURCES (INCLUDING REFERENCE DESIGNS), APPLICATION OR OTHER DESIGN ADVICE, WEB TOOLS, SAFETY INFORMATION, AND OTHER RESOURCES "AS IS" AND WITH ALL FAULTS, AND DISCLAIMS ALL WARRANTIES, EXPRESS AND IMPLIED, INCLUDING WITHOUT LIMITATION ANY IMPLIED WARRANTIES OF MERCHANTABILITY, FITNESS FOR A PARTICULAR PURPOSE OR NON-INFRINGEMENT OF THIRD PARTY INTELLECTUAL PROPERTY RIGHTS.

These resources are intended for skilled developers designing with TI products. You are solely responsible for (1) selecting the appropriate TI products for your application, (2) designing, validating and testing your application, and (3) ensuring your application meets applicable standards, and any other safety, security, regulatory or other requirements.

These resources are subject to change without notice. TI grants you permission to use these resources only for development of an application that uses the TI products described in the resource. Other reproduction and display of these resources is prohibited. No license is granted to any other TI intellectual property right or to any third party intellectual property right. TI disclaims responsibility for, and you will fully indemnify TI and its representatives against, any claims, damages, costs, losses, and liabilities arising out of your use of these resources.

TI's products are provided subject to [TI's Terms of Sale](#) or other applicable terms available either on [ti.com](https://www.ti.com) or provided in conjunction with such TI products. TI's provision of these resources does not expand or otherwise alter TI's applicable warranties or warranty disclaimers for TI products.

TI objects to and rejects any additional or different terms you may have proposed.

Mailing Address: Texas Instruments, Post Office Box 655303, Dallas, Texas 75265

Copyright © 2025, Texas Instruments Incorporated