

THREE PHASE PWM MOTOR DRIVER

Check for Samples: [DRV8332-HT](#)

FEATURES

- High-Efficiency Power Stage (up to 97%) with Low $R_{DS(on)}$ MOSFETs (80 m Ω at $T_J = 25^\circ\text{C}$)
- Operating Supply Voltage up to 50 V (70 V Absolute Maximum)
- Up to 5 A Continuous Phase Current (7 A Peak)
- Independent Control of Three Phases
- PWM Operating Frequency up to 500 kHz
- Integrated Self-Protection Circuits Including Undervoltage, Overtemperature, Overload, and Short Circuit
- Programmable Cycle-by-Cycle Current Limit Protection
- Independent Supply and Ground Pins for Each Half Bridge
- Intelligent Gate Drive and Cross Conduction Prevention
- No External Snubber or Schottky Diode is Required

APPLICATIONS

- BLDC Motors
- Three Phase Permanent Magnet Synchronous Motors
- Inverters
- Half Bridge Drivers
- Robotic Control Systems

SUPPORTS EXTREME TEMPERATURE APPLICATIONS

- Controlled Baseline
- One Assembly and Test Site
- One Fabrication Site
- Available in Extreme (-55°C to 175°C) Temperature Range ⁽¹⁾
- Extended Product Life Cycle
- Extended Product-Change Notification
- Product Traceability
- Texas Instruments high temperature products utilize highly optimized silicon (die) solutions with design and process enhancements to maximize performance over extended temperatures. All devices are characterized and qualified for 1000 hours continuous operating life at maximum rated temperature.

Simplified Application Diagram

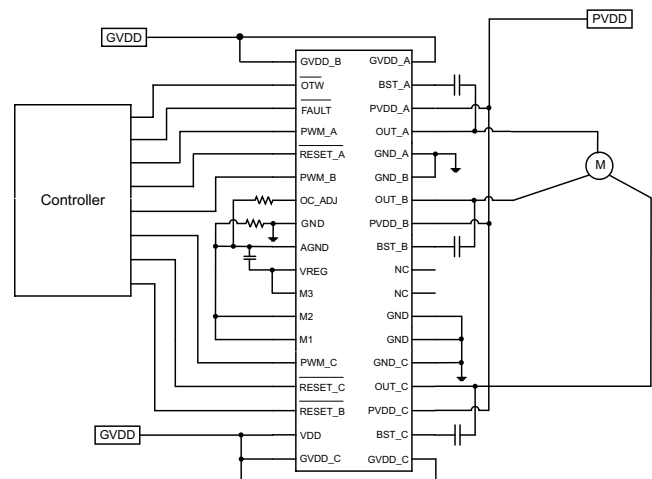

(1) Custom temperature ranges available

DESCRIPTION

The DRV8332 is a high performance, integrated three phase motor driver with an advanced protection system.

Because of the low $R_{DS(on)}$ of the power MOSFETs and intelligent gate drive design, the efficiency of this motor driver can be up to 97%, which enables the use of smaller power supplies and heatsinks, and is a good candidate for energy efficient applications.



Please be aware that an important notice concerning availability, standard warranty, and use in critical applications of Texas Instruments semiconductor products and disclaimers thereto appears at the end of this data sheet.

DESCRIPTION (CONTINUED)

The DRV8332 requires two power supplies, one at 12 V for GVDD and VDD, and another up to 50 V for PVDD. The DRV8332 can operate at up to 500-kHz switching frequency while still maintain precise control and high efficiency. It also has an innovative protection system safeguarding the device against a wide range of fault conditions that could damage the system. These safeguards are short-circuit protection, overcurrent protection and undervoltage protection. The DRV8332 has a current-limiting circuit that prevents device shutdown during load transients such as motor start-up. A programmable overcurrent detector allows adjustable current limit and protection level to meet different motor requirements.

The DRV8332 has unique independent supply and ground pins for each half bridge, which makes it possible to provide current measurement through external shunt resistor and support half bridge drivers with different power supply voltage requirements.



This integrated circuit can be damaged by ESD. Texas Instruments recommends that all integrated circuits be handled with appropriate precautions. Failure to observe proper handling and installation procedures can cause damage.

ESD damage can range from subtle performance degradation to complete device failure. Precision integrated circuits may be more susceptible to damage because very small parametric changes could cause the device not to meet its published specifications.

ORDERING INFORMATION⁽¹⁾

T _A	PACKAGE	ORDERABLE PART NUMBER	TOP-SIDE MARKING
-55°C to 175°C	DDV	DRV8332HDDV	DRV8332H

- (1) For the most current package and ordering information, see the Package Option Addendum at the end of this document, or see the TI website at www.ti.com.

ABSOLUTE MAXIMUM RATINGS

Over operating free-air temperature range unless otherwise noted ⁽¹⁾

	VALUE
VDD to GND	-0.3 V to 13.2 V
GVDD_X to GND	-0.3 V to 13.2 V
PVDD_X to GND_X ⁽²⁾	-0.3 V to 70 V
OUT_X to GND_X ⁽²⁾	-0.3 V to 70 V
BST_X to GND_X ⁽²⁾	-0.3 V to 80 V
Maximum bootstrap in rush current, IBST_In	0.4 A
Transient peak output current (per pin), pulse width limited by internal over-current protection circuit.	16 A
Transient peak output current for latch shut down (per pin)	20 A
VREG to AGND	-0.3 V to 4.2 V
GND_X to GND	-0.3 V to 0.3 V
GND to AGND	-0.3 V to 0.3 V
PWM_X, $\overline{\text{RESET}}_X$ to GND	-0.3 V to 4.2 V
OC_ADJ, M1, M2, M3 to AGND	-0.3 V to 4.2 V
$\overline{\text{FAULT}}$, $\overline{\text{OTW}}$ to GND	-0.3 V to 7 V
Maximum continuous sink current ($\overline{\text{FAULT}}$, $\overline{\text{OTW}}$)	9 mA
Maximum operating junction temperature range, T _J	-55°C to 185°C
Storage temperature, T _{STG}	-55°C to 175°C

- (1) Stresses beyond those listed under *Absolute Maximum Ratings* may cause permanent damage to the device. These are stress ratings only, and functional operation of the device at these or any other conditions beyond those indicated under *Recommended Operating Conditions* is not implied. Exposure to absolute-maximum-rated conditions for extended periods may affect device reliability.
- (2) These voltages represent the dc voltage + peak ac waveform measured at the terminal of the device in all conditions.

RECOMMENDED OPERATING CONDITIONS

		MIN	NOM	MAX	UNIT
PVDD_X	Half bridge X (A, B, or C) DC supply voltage	0	50	52.5	V
GVDD_X	Supply for logic regulators and gate-drive circuitry	10.8	12	13.2	V
VDD	Digital regulator supply voltage	10.8	12	13.2	V
I _{O_PULSE}	Pulsed peak current per output pin (could be limited by thermal)			7	A
I _O	Continuous current per output pin (DRV8332)			5	A
F _{SW}	PWM switching frequency			380	kHz
R _{OC_P_CBC}	OC programming resistor range in cycle-by-cycle current limit modes	30		200	kΩ
C _{BST}	Bootstrap capacitor range	33		220	nF
T _{ON_MIN}	Minimum PWM pulse duration, low side		50		ns
T _J	Operating junction temperature	-55		175	°C

THERMAL INFORMATION

THERMAL METRIC ⁽¹⁾		DRV8332-HT	UNITS
		DDV	
		44 PINS	
θ_{JA}	Junction-to-ambient thermal resistance ⁽²⁾	42.6	°C/W
θ_{JcTop}	Junction-to-case (top) thermal resistance ⁽³⁾	0.2	
θ_{JB}	Junction-to-board thermal resistance ⁽⁴⁾	17.4	
ψ_{JT}	Junction-to-top characterization parameter ⁽⁵⁾	0.5	
ψ_{JB}	Junction-to-board characterization parameter ⁽⁶⁾	17.4	
θ_{JcBot}	Junction-to-case (bottom) thermal resistance ⁽⁷⁾	N/A	

- (1) For more information about traditional and new thermal metrics, see the *IC Package Thermal Metrics* application report, [SPRA953](#).
- (2) The junction-to-ambient thermal resistance under natural convection is obtained in a simulation on a JEDEC-standard, high-K board, as specified in JESD51-7, in an environment described in JESD51-2a.
- (3) The junction-to-case (top) thermal resistance is obtained by simulating a cold plate test on the package top. No specific JEDEC-standard test exists, but a close description can be found in the ANSI SEMI standard G30-88.
- (4) The junction-to-board thermal resistance is obtained by simulating in an environment with a ring cold plate fixture to control the PCB temperature, as described in JESD51-8.
- (5) The junction-to-top characterization parameter, ψ_{JT} , estimates the junction temperature of a device in a real system and is extracted from the simulation data for obtaining θ_{JA} , using a procedure described in JESD51-2a (sections 6 and 7).
- (6) The junction-to-board characterization parameter, ψ_{JB} , estimates the junction temperature of a device in a real system and is extracted from the simulation data for obtaining θ_{JA} , using a procedure described in JESD51-2a (sections 6 and 7).
- (7) The junction-to-case (bottom) thermal resistance is obtained by simulating a cold plate test on the exposed (power) pad. No specific JEDEC standard test exists, but a close description can be found in the ANSI SEMI standard G30-88.

MODE SELECTION PINS

MODE PINS			OUTPUT CONFIGURATION	DESCRIPTION
M3	M2	M1		
1	0	0	1 3PH or 3 HB	Three-phase or three half bridges with cycle-by-cycle current limit
1	0	1	1 3PH or 3 HB	Three-phase or three half bridges with OC latching shutdown (no cycle-by-cycle current limit)
0	x	x		Reserved
1	1	x		Reserved

DEVICE INFORMATION

Pin Assignment

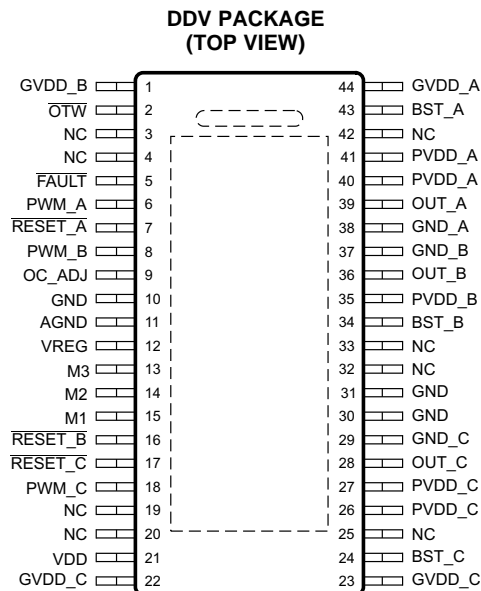

Pin Functions

NAME	PIN	FUNCTION ⁽¹⁾	DESCRIPTION
AGND	11	P	Analog ground
BST_A	43	P	High side bootstrap supply (BST), external capacitor to OUT_A required
BST_B	34	P	High side bootstrap supply (BST), external capacitor to OUT_B required
BST_C	24	P	High side bootstrap supply (BST), external capacitor to OUT_C required
GND	10, 30, 31	P	Ground
GND_A	38	P	Power ground for half-bridge A
GND_B	37	P	Power ground for half-bridge B
GND_C	29	P	Power ground for half-bridge C
GVDD_A	44	P	Gate-drive voltage supply
GVDD_B	2	P	Gate-drive voltage supply
GVDD_C	22, 23	P	Gate-drive voltage supply
M1	15	I	Mode selection pin
M2	14	I	Reserved mode selection pin, AGND connection is recommended
M3	13	I	Reserved mode selection pin, VREG connection is recommended
NC	3, 4, 19, 20, 25, 32, 33, 42	-	No connection pin. Ground connection is recommended
OC_ADJ	9	O	Analog overcurrent programming pin, requires resistor to AGND
OTW	2	O	Overtemperature warning signal, open-drain, active-low. An internal pull-up resistor to VREG (3.3 V) is provided on output. Level compliance for 5-V logic can be obtained by adding external pull-up resistor to 5 V
OUT_A	39	O	Output, half-bridge A
OUT_B	36	O	Output, half-bridge B
OUT_C	28	O	Output, half-bridge C
PVDD_A	40, 41	P	Power supply input for half-bridge A requires close decoupling capacitor to ground.
PVDD_B	35	P	Power supply input for half-bridge B requires close decoupling capacitor to ground.
PVDD_C	26, 27	P	Power supply input for half-bridge C requires close decoupling capacitor to ground.
PWM_A	6	I	Input signal for half-bridge A

(1) I = input, O = output, P = power, T = thermal

NAME	PIN	FUNCTION (1)	DESCRIPTION
PWM_B	8	I	Input signal for half-bridge B
PWM_C	18	I	Input signal for half-bridge C
$\overline{\text{RESET_A}}$	7	I	Reset signal for half-bridge A, active-low
$\overline{\text{RESET_B}}$	16	I	Reset signal for half-bridge B, active-low
$\overline{\text{RESET_C}}$	17	I	Reset signal for half-bridge C, active-low
FAULT	5	O	Fault signal, open-drain, active-low. An internal pull-up resistor to VREG (3.3 V) is provided on output. Level compliance for 5-V logic can be obtained by adding external pull-up resistor to 5 V
VDD	21	P	Power supply for digital voltage regulator requires capacitor to ground for decoupling.
VREG	12	P	Digital regulator supply filter pin requires 0.1- μF capacitor to AGND.

SYSTEM BLOCK DIAGRAM

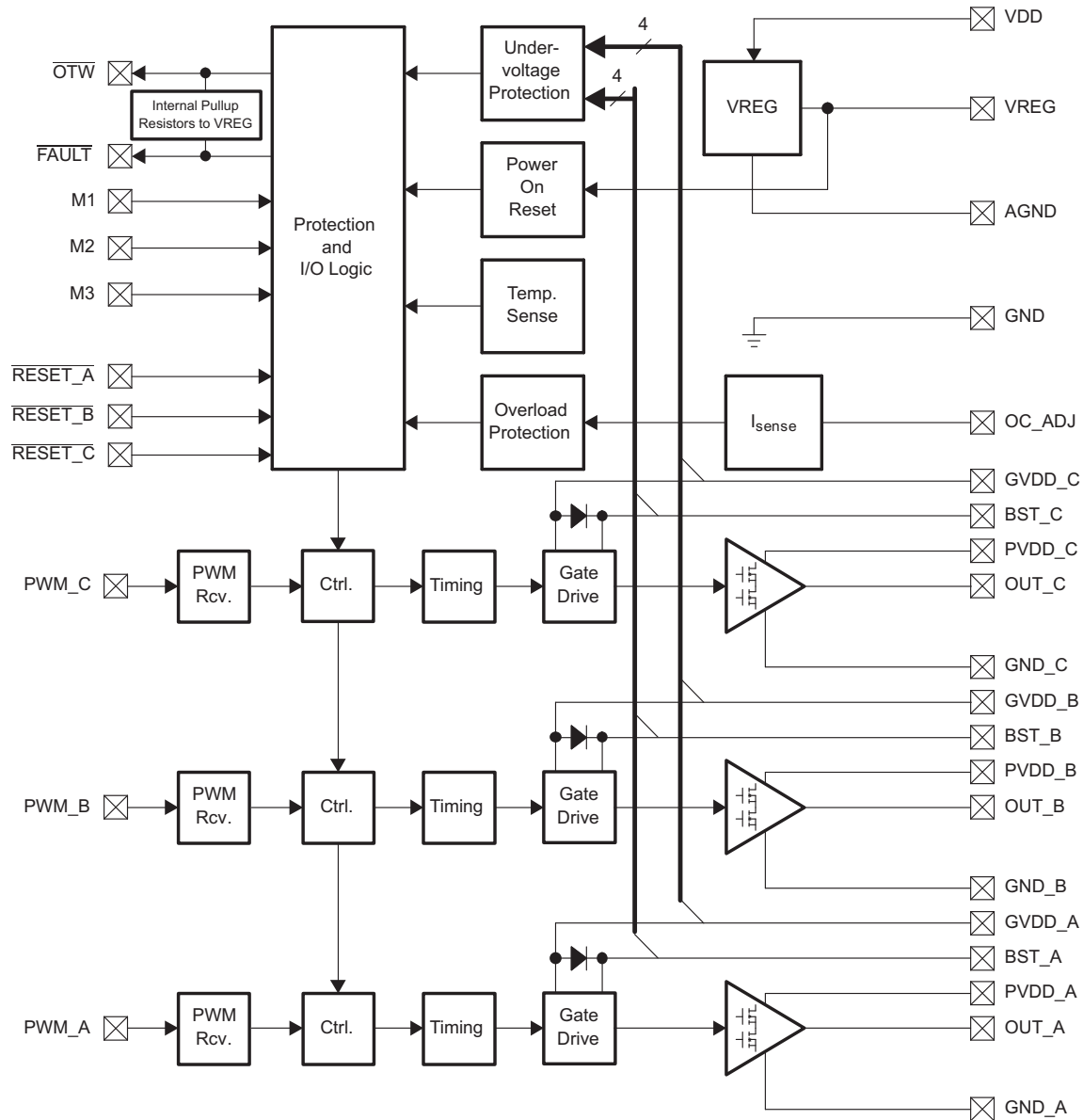

ELECTRICAL CHARACTERISTICS

$T_J = -55^{\circ}\text{C}$ to 175°C , $\text{PVDD} = 50\text{ V}$, $\text{GVDD} = \text{VDD} = 12\text{ V}$, $f_{\text{sw}} = 380\text{ kHz}$, unless otherwise noted. All performance is in accordance with recommended operating conditions unless otherwise specified.

PARAMETER		TEST CONDITIONS	MIN	TYP	MAX	UNIT
Internal Voltage Regulator and Current Consumption						
V_{REG}	Voltage regulator, only used as a reference node	$\text{VDD} = 12\text{ V}$	2.85	3.3	3.75	V
I_{VDD}	VDD supply current	Idle, reset mode		9	15	mA
		Operating, 50% duty cycle		10.5		
I_{GVDD_X}	Gate supply current per half-bridge	Reset mode		1.7	2.5	mA
		Operating, 50% duty cycle		8		
I_{PVDD_X}	Half-bridge X (A, B, or C) idle current	Reset mode		0.7	1	mA
Output Stage						
$R_{\text{DS(on)}}$	MOSFET drain-to-source resistance, low side (LS)	$T_J = 25^{\circ}\text{C}$, $\text{GVDD} = 12\text{ V}$		260		m Ω
	MOSFET drain-to-source resistance, high side (HS)	$T_J = 25^{\circ}\text{C}$, $\text{GVDD} = 12\text{ V}$		260		m Ω
V_F	Diode forward voltage drop	$T_J = 25^{\circ}\text{C} - 125^{\circ}\text{C}$, $I_O = 5\text{ A}$		1		V
t_R	Output rise time	Resistive load, $I_O = 5\text{ A}$		14		ns
t_F	Output fall time	Resistive load, $I_O = 5\text{ A}$		14		ns
$t_{\text{PD_ON}}$	Propagation delay when FET is on	Resistive load, $I_O = 5\text{ A}$		38		ns
$t_{\text{PD_OFF}}$	Propagation delay when FET is off	Resistive load, $I_O = 5\text{ A}$		38		ns
t_{DT}	Dead time between HS and LS FETs	Resistive load, $I_O = 5\text{ A}$		5.5		ns
I/O Protection						
$V_{\text{uvp,G}}$	Gate supply voltage GVDD_X undervoltage protection threshold			8.5		V
$V_{\text{uvp,hyst}}^{(1)}$	Hysteresis for gate supply undervoltage event			0.3		V
I_{OC}	Overcurrent limit protection	Resistor—programmable, nominal, $R_{\text{OCP}} = 36\text{ k}\Omega$		7.4		A
t_{OCT}	Overcurrent response time	Time from application of short condition to Hi-Z of affected FET(s)		250		ns
Static Digital Specifications						
V_{IH}	High-level input voltage	PWM_A , PWM_B , PWM_C , M1, M2, M3		2	3.6	V
V_{IH}	High-level input voltage	RESET_A , RESET_B , RESET_C		2	3.6	V
V_{IL}	Low-level input voltage	PWM_A , PWM_B , PWM_C , M1, M2, M3, RESET_A , RESET_B , RESET_C			0.8	V
I_{lkG}	Input leakage current		-100		100	μA
OTW / FAULT						
$R_{\text{INT_PU}}$	Internal pullup resistance, $\overline{\text{OTW}}$ to VREG , $\overline{\text{FAULT}}$ to VREG		20	26	35	k Ω
V_{OH}	High-level output voltage	Internal pullup resistor only	1.95	3.3	3.65	V
V_{OL}	Low-level output voltage	$I_O = 4\text{ mA}$		0.2	0.4	V

(1) Specified by design

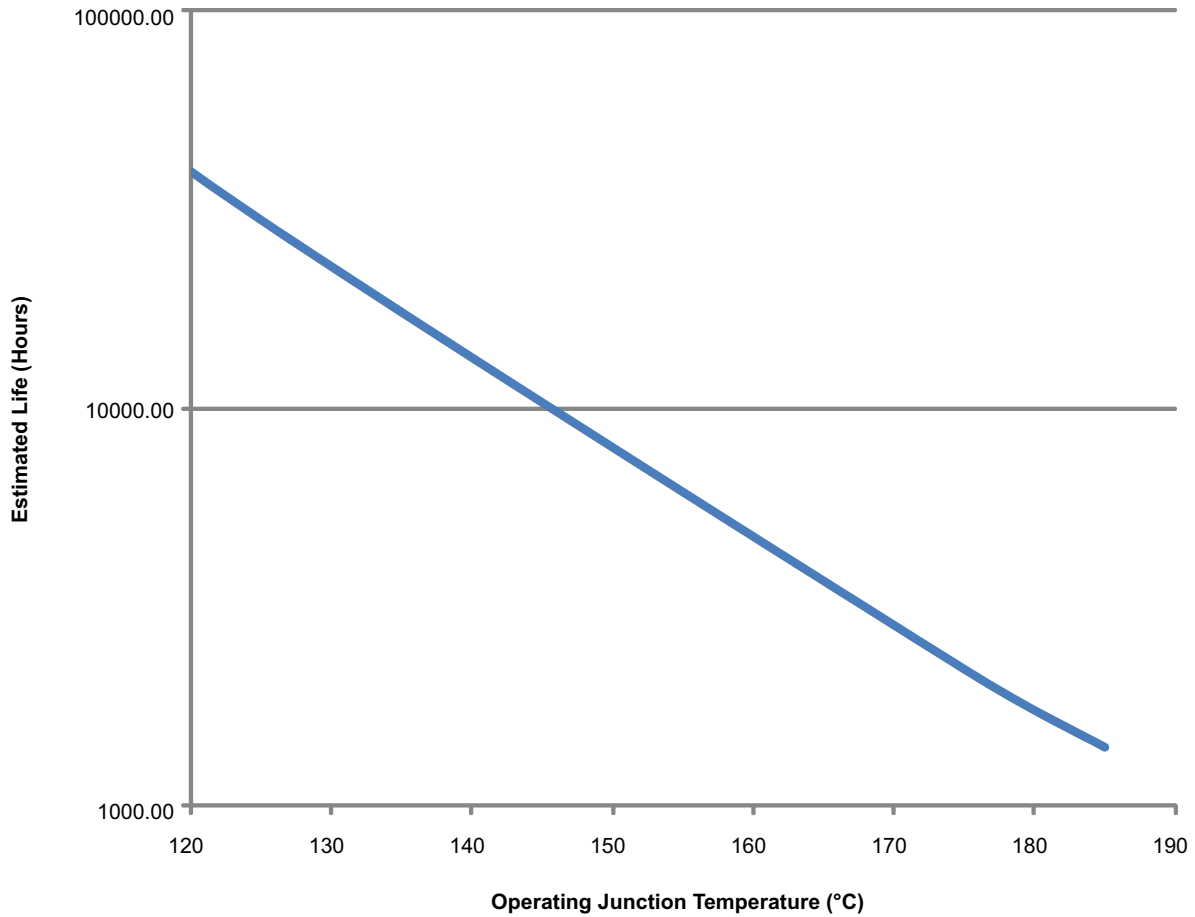

- (1) See datasheet for absolute maximum and minimum recommended operating conditions.
- (2) Silicon operating life design goal is 10 years at 105°C junction temperature (does not include package interconnect life).
- (3) The predicted operating lifetime vs. junction temperature is based on reliability modeling using electromigration as the dominant failure mechanism affecting device wearout for the specific device process and design characteristics.

Figure 1. Electromigration Fail Mode Derating Chart

TYPICAL CHARACTERISTICS

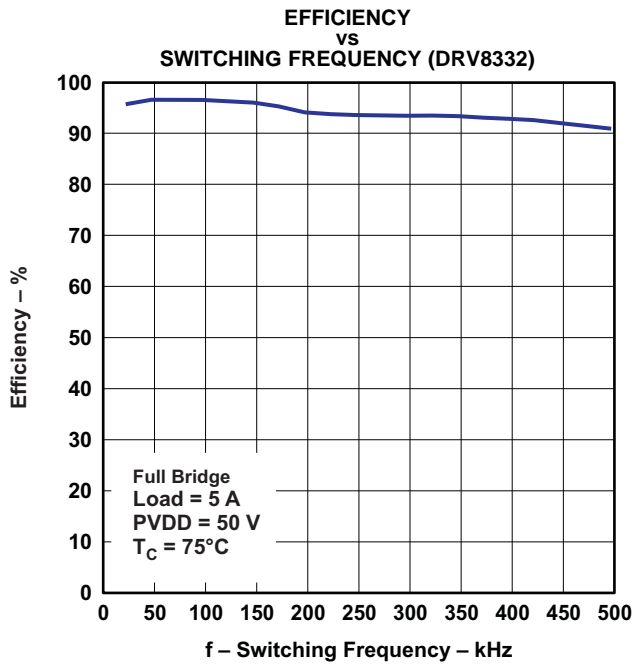

Figure 2.

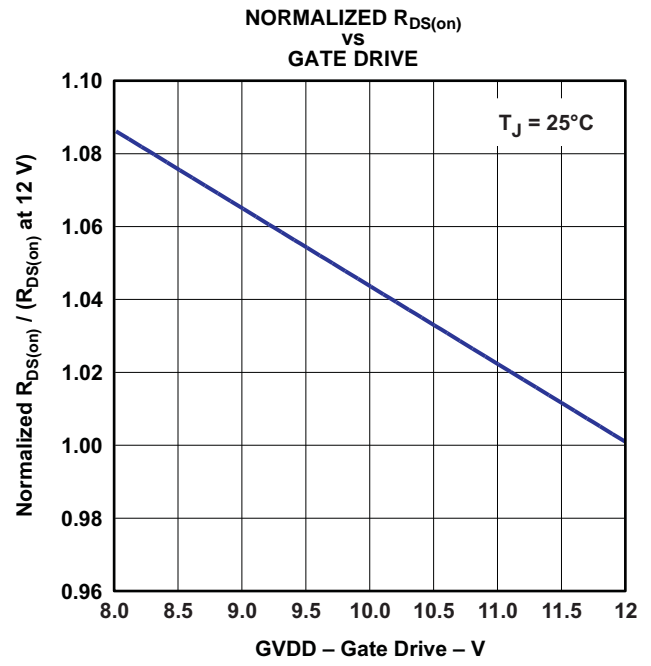

Figure 3.

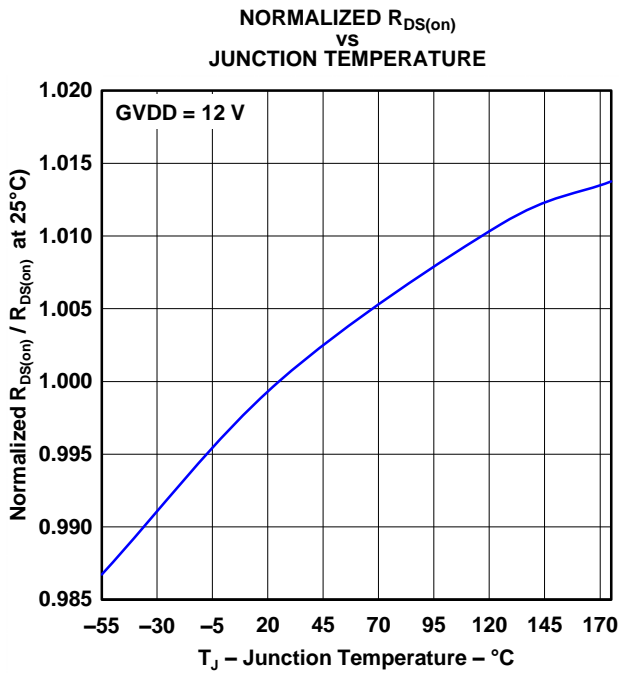

Figure 4.

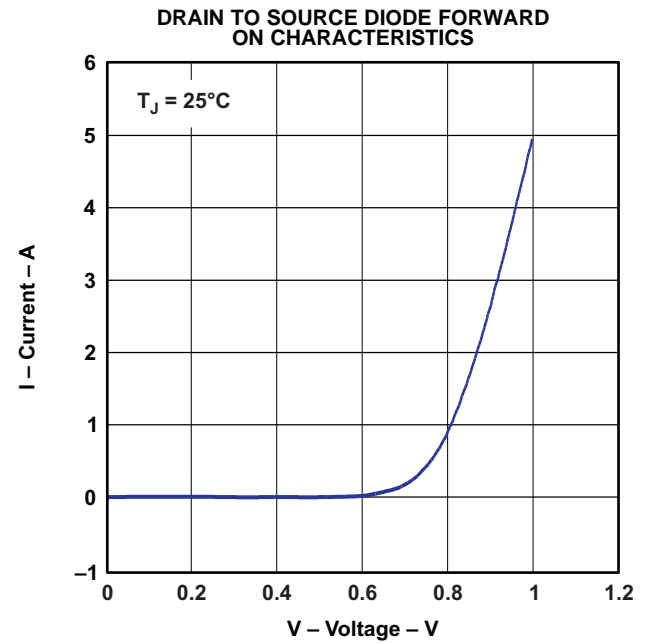

Figure 5.

TYPICAL CHARACTERISTICS (continued)
OUTPUT DUTY CYCLE
VS
INPUT DUTY CYCLE

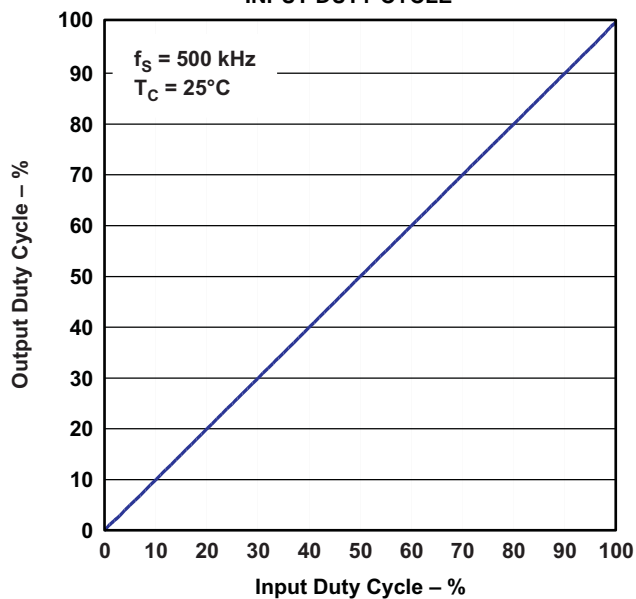

Figure 6.

THEORY OF OPERATION

POWER SUPPLIES

To facilitate system design, the DRV8332 needs only a 12-V supply in addition to H-Bridge power supply (PVDD). An internal voltage regulator provides suitable voltage levels for the digital and low-voltage analog circuitry. Additionally, the high-side gate drive requiring a floating voltage supply, which is accommodated by built-in bootstrap circuitry requiring external bootstrap capacitor.

To provide symmetrical electrical characteristics, the PWM signal path, including gate drive and output stage, is designed as identical, independent half-bridges. For this reason, each half-bridge has a separate gate drive supply (GVDD_X), a bootstrap pin (BST_X), and a power-stage supply pin (PVDD_X). Furthermore, an additional pin (VDD) is provided as supply for all common circuits. Special attention should be paid to place all decoupling capacitors as close to their associated pins as possible. In general, inductance between the power supply pins and decoupling capacitors must be avoided. Furthermore, decoupling capacitors need a short ground path back to the device.

For a properly functioning bootstrap circuit, a small ceramic capacitor (an X5R or better) must be connected from each bootstrap pin (BST_X) to the power-stage output pin (OUT_X). When the power-stage output is low, the bootstrap capacitor is charged through an internal diode connected between the gate-drive power-supply pin (GVDD_X) and the bootstrap pin. When the power-stage output is high, the bootstrap capacitor potential is shifted above the output potential and thus provides a suitable voltage supply for the high-side gate driver. In an application with PWM switching frequencies in the range from 10 kHz to 500 kHz, the use of 100-nF ceramic capacitors (X5R or better), size 0603 or 0805, is recommended for the bootstrap supply. These 100-nF capacitors ensure sufficient energy storage, even during minimal PWM duty cycles, to keep the high-side power stage FET fully turned on during the remaining part of the PWM cycle. In an application running at a switching frequency lower than 10 kHz, the bootstrap capacitor might need to be increased in value.

Special attention should be paid to the power-stage power supply; this includes component selection, and routing. As indicated, each half-bridge has independent power-stage supply pin (PVDD_X). For optimal electrical performance, EMI compliance, and system reliability, it is important that each PVDD_X pin is decoupled with a ceramic capacitor (X5R or better) placed as close as possible to each supply pin.

The 12-V supply should be from a low-noise, low-output-impedance voltage regulator. Likewise, the 50-V power-stage supply is assumed to have low output impedance and low noise. The power-supply sequence is not critical as facilitated by the internal power-on-reset circuit. Moreover, the DRV8332 are fully protected against erroneous power-stage turn-on due to parasitic gate charging. Thus, voltage-supply ramp rates (dv/dt) are non-critical within the specified voltage range (see the *Recommended Operating Conditions* section of this data sheet).

SYSTEM POWER-UP/POWER-DOWN SEQUENCE

Powering Up

The DRV8332 does not require a power-up sequence. The outputs of the H-bridges remain in a high impedance state until the gate-drive supply voltage GVDD_X and VDD voltage are above the undervoltage protection (UVP) voltage threshold (see the *Electrical Characteristics* section of this data sheet). Although not specifically required, holding RESET_A, RESET_B, and RESET_C in a low state while powering up the device is recommended. This allows an internal circuit to charge the external bootstrap capacitors by enabling a weak pulldown of the half-bridge output.

Powering Down

The DRV8332 does not require a power-down sequence. The device remains fully operational as long as the gate-drive supply (GVDD_X) voltage and VDD voltage are above the UVP voltage threshold (see the *Electrical Characteristics* section of this data sheet). Although not specifically required, it is a good practice to hold RESET_A, RESET_B and RESET_C low during power down to prevent any unknown state during this transition.

ERROR REPORTING

The $\overline{\text{FAULT}}$ and $\overline{\text{OTW}}$ pins are both active-low, open-drain outputs. Their function is for protection-mode signaling to a PWM controller or other system-control device.

Any fault resulting in device shutdown, such as overtemperature shut down, overcurrent shut-down, or undervoltage protection, is signaled by the $\overline{\text{FAULT}}$ pin going low. Likewise, $\overline{\text{OTW}}$ goes low when the device junction temperature exceeds 125°C (see [Table 1](#)).

Table 1. Protection Mode Signal Descriptions

FAULT	OTW	DESCRIPTION
0	0	Overtemperature warning and (overtemperature shut down or overcurrent shut down or undervoltage protection) occurred
0	1	Overcurrent shut-down or GVDD undervoltage protection occurred
1	0	Overtemperature warning
1	1	Device under normal operation

TI recommends monitoring the $\overline{\text{OTW}}$ signal using the system microcontroller and responding to an $\overline{\text{OTW}}$ signal by reducing the load current to prevent further heating of the device resulting in device overtemperature shutdown (OTSD).

To reduce external component count, an internal pullup resistor to internal VREG (3.3 V) is provided on both $\overline{\text{FAULT}}$ and $\overline{\text{OTW}}$ outputs. Level compliance for 5-V logic can be obtained by adding external pull-up resistors to 5 V (see the *Electrical Characteristics* section of this data sheet for further specifications).

DEVICE PROTECTION SYSTEM

The DRV8332 contains advanced protection circuitry carefully designed to facilitate system integration and ease of use, as well as to safeguard the device from permanent failure due to a wide range of fault conditions such as short circuits, overcurrent, overtemperature, and undervoltage. The DRV8332 responds to a fault by immediately setting the half bridge outputs in a high-impedance (Hi-Z) state and asserting the $\overline{\text{FAULT}}$ pin low. In situations other than overcurrent or overtemperature, the device automatically recovers when the fault condition has been removed or the gate supply voltage has increased. For highest possible reliability, reset the device externally no sooner than 1 second after the shutdown when recovering from an overcurrent shut down (OCSD) or OTSD fault.

Bootstrap Capacitor Under Voltage Protection

When the device runs at a low switching frequency (e.g. less than 10 kHz with a 100-nF bootstrap capacitor), the bootstrap capacitor voltage might not be able to maintain a proper voltage level for the high-side gate driver. A bootstrap capacitor undervoltage protection circuit (BST_UVP) will prevent potential failure of the high-side MOSFET. When the voltage on the bootstrap capacitors is less than the required value for safe operation, the DRV8332 will initiate bootstrap capacitor recharge sequences (turn off high side FET for a short period) until the bootstrap capacitors are properly charged for safe operation. This function may also be activated when PWM duty cycle is too high (e.g. less than 20 ns off time at 10 kHz). Note that bootstrap capacitor might not be able to be charged if no load or extremely light load is presented at output during BST_UVP operation, so it is recommended to turn on the low side FET for at least 50 ns for each PWM cycle to avoid BST_UVP operation if possible.

For all applications, it is recommended to add 26-Ω resistor between the GVDD power supply and GVDD_X pins to limit the inrush current on the internal bootstrap diodes.

Overcurrent (OC) Protection

The DRV8332 has independent, fast-reacting current detectors with programmable trip threshold (OC threshold) on all high-side and low-side power-stage FETs. There are two settings for OC protection through mode selection pins: cycle-by-cycle (CBC) current limiting mode and OC latching (OCL) shut down mode.

In CBC current limiting mode, the detector outputs are monitored by two protection systems. The first protection system controls the power stage in order to prevent the output current from further increasing, i.e., it performs a CBC current-limiting function rather than prematurely shutting down the device. This feature could effectively limit the inrush current during motor start-up or transient without damaging the device. During short to power and short to ground conditions, the current limit circuitry might not be able to control the current to a proper level, a second protection system triggers a latching shutdown, resulting in the related half bridge being set in the high-impedance (Hi-Z) state. Current limiting and overcurrent protection are independent for half-bridges A, B, and C, respectively.

Figure 7 illustrates cycle-by-cycle operation with high side OC event and Figure 8 shows cycle-by-cycle operation with low side OC. Dashed lines are the operation waveforms when no CBC event is triggered and solid lines show the waveforms when CBC event is triggered. In CBC current limiting mode, when low side FET OC is detected, the device will turn off the affected low side FET and keep the high side FET at the same half bridge off until next PWM cycle; when high side FET OC is detected, the device will turn off the affected high side FET and turn on the low side FET at the half bridge until next PWM cycle.

It is important to note that if the input to a half bridge is held to a constant value when an over current event occurs in CBC, then the associated half bridge will be in a HI-Z state upon the over current event ending. Cycling IN_X will allow OUT_X to resume normal operation.

In OC latching shut down mode, the CBC current limit and error recovery circuits are disabled and an overcurrent condition will cause the device to shutdown immediately. After shutdown, RESET_A, RESET_B, and RESET_C must be asserted to restore normal operation after the overcurrent condition is removed.

For added flexibility, the OC threshold is programmable using a single external resistor connected between the OC_ADJ pin and AGND pin. See Table 2 for information on the correlation between programming-resistor value and the OC threshold.

The values in Table 2 show typical OC thresholds for a given resistor. Assuming a fixed resistance on the OC_ADJ pin across multiple devices, a 20% device-to-device variation in OC threshold measurements is possible. Therefore, this system is designed for system protection and not for precise current control.

Table 2. Programming-Resistor Values and OC Threshold

OC-ADJUST RESISTOR VALUES (kΩ)	MAXIMUM CURRENT BEFORE OC OCCURS (A)
30	8.8
36	7.4
39	6.9
43	6.3
47	5.8
56	4.9
68	4.1

Table 2. Programming-Resistor Values and OC Threshold (continued)

OC-ADJUST RESISTOR VALUES (kΩ)	MAXIMUM CURRENT BEFORE OC OCCURS (A)
82	3.4
100	2.8
120	2.4
150	1.9
200	1.4

It should be noted that a properly functioning overcurrent detector assumes the presence of a proper inductor or power ferrite bead at the power-stage output. Short-circuit protection is not guaranteed with direct short at the output pins of the power stage.

Undervoltage Protection (UVP) and Power-On Reset (POR)

The UVP and POR circuits of the DRV8332 fully protect the device in any power-up / down and brownout situation. While powering up, the POR circuit resets the overcurrent circuit and ensures that all circuits are fully operational when the GVDD_X and VDD supply voltages reach 9.8 V (typical). Although GVDD_X and VDD are independently monitored, a supply voltage drop below the UVP threshold on any VDD or GVDD_X pin results in all half-bridge outputs immediately being set in the high-impedance (Hi-Z) state and FAULT being asserted low. The device automatically resumes operation when all supply voltage on the bootstrap capacitors have increased above the UVP threshold.

DEVICE RESET

Three reset pins are provided for independent control of half-bridges A, B, and C. When RESET_X is asserted low, two power-stage FETs in half-bridges X are forced into a high-impedance (Hi-Z) state.

A rising-edge transition on reset input allows the device to resume operation after a shut-down fault. That is, when half-bridge X has OC shutdown in CBC mode, a low to high transition of RESET_X pin will clear the fault and FAULT pin. When an OTSD occurs or OC shutdown in Latching mode occurs, all three RESET_A, RESET_B, and RESET_C need to have a low to high transition to clear the fault and reset FAULT signal.

DIFFERENT OPERATIONAL MODES

The DRV8332 supports two different modes of operation:

1. Three-phase (3PH) or three half bridges (HB) with CBC current limit
2. Three-phase or three half bridges with OC latching shutdown (no CBC current limit)

Because each half bridge has independent supply and ground pins, a shunt sensing resistor can be inserted between PVDD to PVDD_X or GND_X to GND (ground plane). A high side shunt resistor between PVDD and PVDD_X is recommended for differential current sensing because a high bias voltage on the low side sensing could affect device operation. If low side sensing has to be used, a shunt resistor value of 10 mΩ or less or sense voltage 100 mV or less is recommended.

and Figure 9 show the three-phase application examples, and Figure 10 shows how to connect to DRV8332 with some simple logic to accommodate conventional 6 PWM inputs control.

We recommend using complementary control scheme for switching phases to prevent circulated energy flowing inside the phases and to make current limiting feature active all the time. Complementary control scheme also forces the current flowing through sense resistors all the time to have a better current sensing and control of the system.

Figure 11 shows six steps trapezoidal scheme with hall sensor control and Figure 12 shows six steps trapezoidal scheme with sensorless control. The hall sensor sequence in real application might be different than the one we showed in Figure 11 depending on the motor used. Please check motor manufacture datasheet for the right sequence in applications. In six step trapezoidal complementary control scheme, a half bridge with larger than 50% duty cycle will have a positive current and a half bridge with less than 50% duty cycle will have a negative current. For normal operation, changing PWM duty cycle from 50% to 100% will adjust the current from 0 to maximum value with six steps control. It is recommended to apply a minimum 50 ns to 100 ns PWM pulse at each switching cycle at lower side to properly charge the bootstrap cap. The impact of minimum pulse at low side FET is pretty small, e.g., the maximum duty cycle is 99.9% with 100ns minimum pulse on low side. RESET_Xpin can be used to get channel X into high impedance mode. If you prefer PWM switching one channel but hold low side FET of the other channel on (and third channel in Hi-Z) for 2-quadrant mode, OT latching shutdown mode is recommended to prevent the channel with low side FET on stuck in Hi-Z during OC event in CBC mode.

The DRV8332 can also be used for sinusoidal waveform control and field oriented control. Please check TI website MCU motor control library for control algorithms.

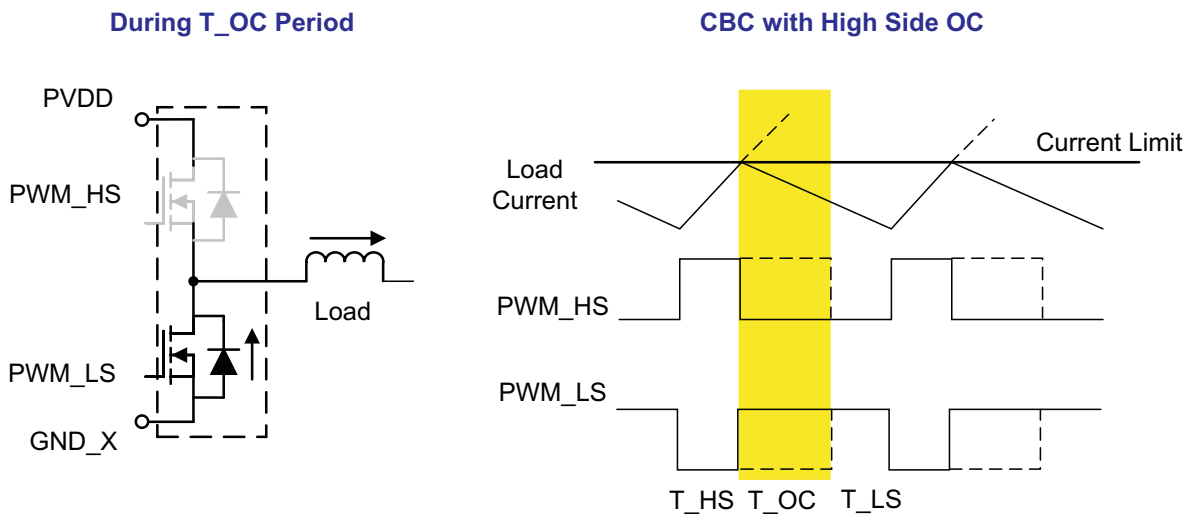

Figure 7. Cycle-by-Cycle Operation with High Side OC (dashed line: normal operation; solid line: CBC event)

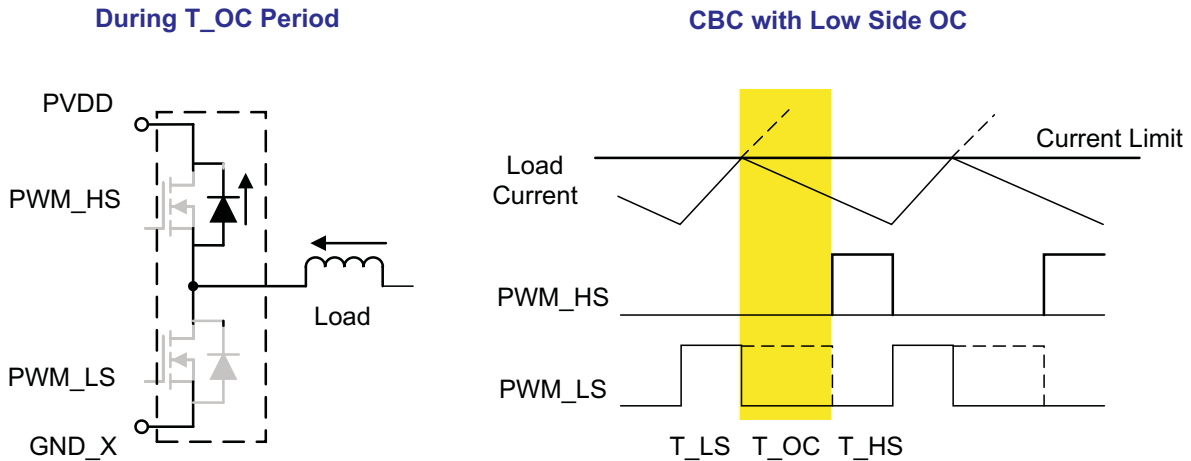

Figure 8. Cycle-by-Cycle Operation with Low Side OC (dashed line: normal operation; solid line: CBC event)

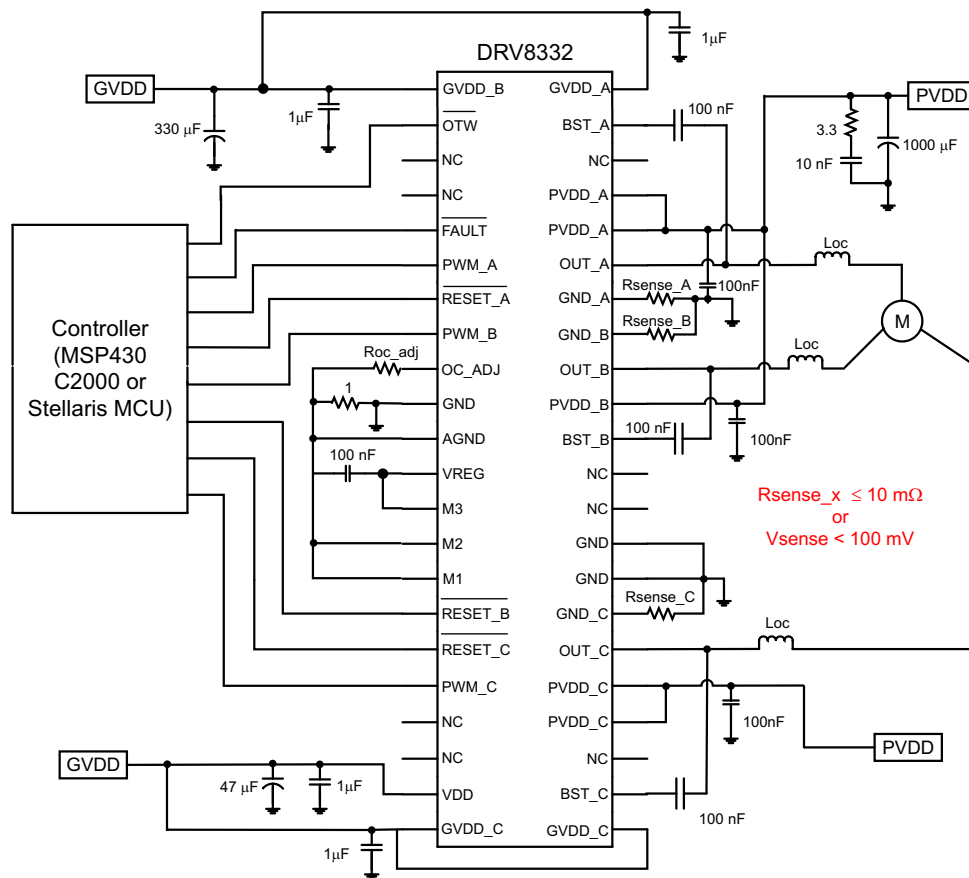

Figure 9. DRV8332 Application Diagram for Three-Phase Operation

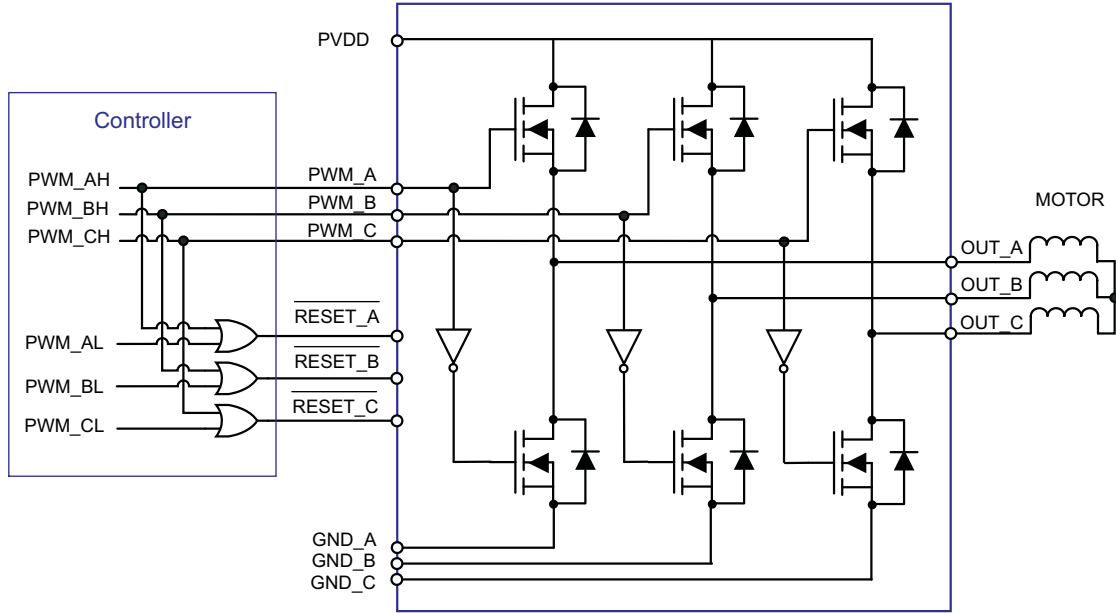

Figure 10. Control Signal Logic with Conventional 6 PWM Input Scheme

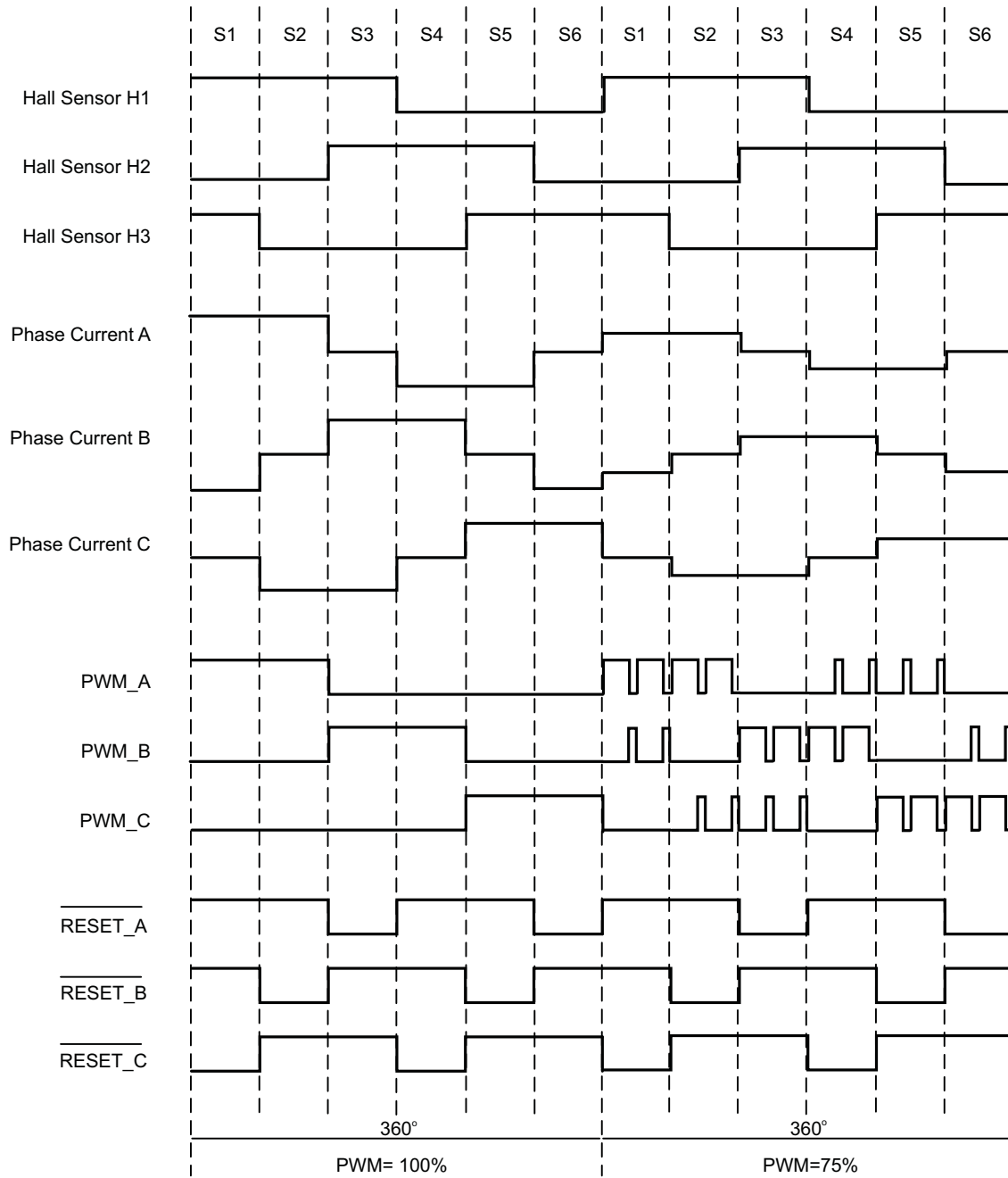

Figure 11. Hall Sensor Control with 6 Steps Trapezoidal Scheme

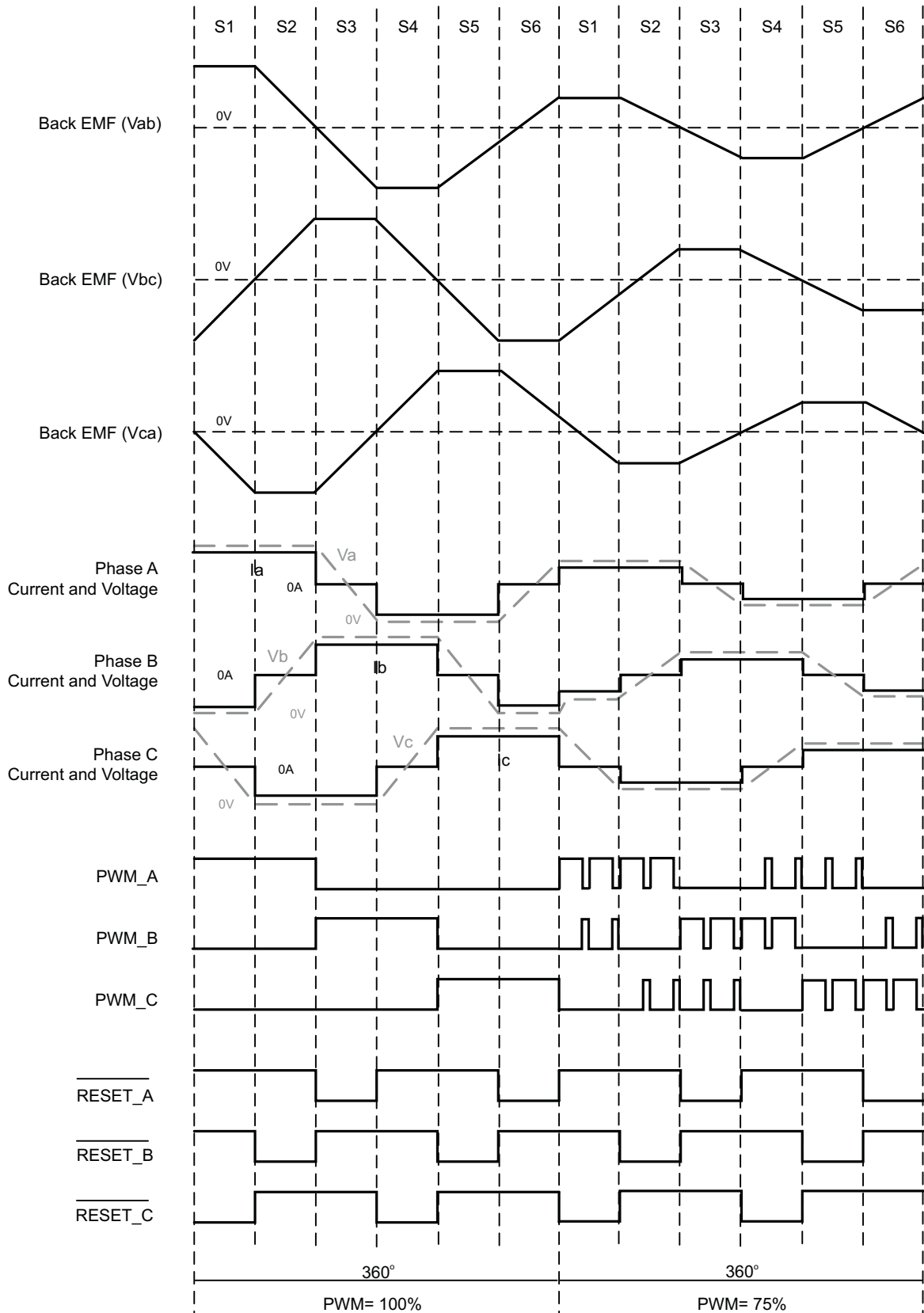

Figure 12. Sensorless Control with 6 Steps Trapezoidal Scheme

APPLICATION INFORMATION

SYSTEM DESIGN RECOMMENDATIONS

Voltage of Decoupling Capacitor

The voltage of the decoupling capacitors should be selected in accordance with good design practices. Temperature, ripple current, and voltage overshoot must be considered. The high frequency decoupling capacitor should use ceramic capacitor with X5R or better rating. For a 50-V application, a minimum voltage rating of 63 V is recommended.

Current Requirement of 12V Power Supply

The DRV8332 requires a 12V power supply for GVDD and VDD pins. The total supply current is pretty low at room temp (less than 50mA), but the current could increase significantly when the device temperature goes too high (e.g. above 125°C), especially at heavy load conditions due to substrate current collection by 12V guard rings. So it is recommended to design the 12V power supply with current capability at least 5-10% of your load current and no less than 100mA to assure the device performance across all temperature range.

VREG Pin

The VREG pin is used for internal logic and should not be used as a voltage source for external circuitries. The capacitor on VREG pin should be connected to AGND.

VDD Pin

The transient current in VDD pin could be significantly higher than average current through VDD pin. A low resistive path to GVDD should be used. A 22- μ F to 47- μ F capacitor should be placed on VDD pin beside the 100-nF to 1- μ F decoupling capacitor to provide a constant voltage during transient.

OTW Pin

$\overline{\text{OTW}}$ reporting indicates the device approaching high junction temperature. This signal can be used with MCU to decrease system power when $\overline{\text{OTW}}$ is low in order to prevent OT shut down at a higher temperature.

No external pull up resistor or 3.3V power supply is needed for 3.3V logic. The $\overline{\text{OTW}}$ pin has an internal pullup resistor connecting to an internal 3.3V to reduce external component count. For 5V logic, an external pull up resistor to 5V is needed.

FAULT Pin

The $\overline{\text{FAULT}}$ pin reports any fault condition resulting in device shut down. No external pull up resistor or 3.3V power supply is needed for 3.3V logic. The $\overline{\text{FAULT}}$ pin has an internal pullup resistor connecting to an internal 3.3V to reduce external component count. For 5V logic, an external pull up resistor to 5V is needed.

OC_ADJ Pin

For accurate control of the overcurrent protection, the OC_ADJ pin has to be connected to AGND through an OC adjust resistor.

PWM_X and RESET_X Pins

It is recommended to connect these pins to either AGND or GND when they are not used, and these pins only support 3.3V logic.

Mode Select Pins

Mode select pins (M1, M2, and M3) should be connected to either VREG (for logic high) or AGND for logic low. It is not recommended to connect mode pins to board ground if 1- Ω resistor is used between AGND and GND.

Output Inductor Selection

For normal operation, inductance in motor (assume larger than 10 μH) is sufficient to provide low di/dt output (e.g. for EMI) and proper protection during overload condition (CBC current limiting feature). So no additional output inductors are needed during normal operation.

However during a short condition, the motor (or other load) could be shorted, so the load inductance might not present in the system anymore; the current in short condition can reach such a high level that may exceed the abs max current rating due to extremely low impedance in the short circuit path and high di/dt before oc detection circuit kicks in. So a ferrite bead or inductor is recommended to utilize the short circuit protection feature in DRV8332. With an external inductor or ferrite bead, the current will rise at a much slower rate and reach a lower current level before oc protection starts. The device will then either operate CBC current limit or OC shut down automatically (when current is well above the current limit threshold) to protect the system.

For a system that has limited space, a power ferrite bead can be used instead of an inductor. The current rating of ferrite bead has to be higher than the RMS current of the system at normal operation. A ferrite bead designed for very high frequency is NOT recommended. A minimum impedance of 10 Ω or higher is recommended at 10 MHz or lower frequency to effectively limit the current rising rate during short circuit condition.

The TDK MPZ2012S300A and MPZ2012S101A (with size of 0805 inch type) have been tested in our system to meet short circuit conditions in the DRV8332. But other ferrite beads that have similar frequency characteristics can be used as well.

For higher power applications, such as in the DRV8332, there might be limited options to select suitable ferrite bead with high current rating. If an adequate ferrite bead cannot be found, an inductor can be used.

The inductance can be calculated as:

$$L_{oc_min} = \frac{PVDD \cdot T_{oc_delay}}{I_{peak} - I_{ave}} \quad (1)$$

Where $T_{oc_delay} = 250 \text{ nS}$, $I_{peak} = 15 \text{ A}$ (below abs max rating).

Because an inductor usually saturates pretty quickly after reaching its current rating, it is recommended to use an inductor with a doubled value or an inductor with a current rating well above the operating condition.

THERMAL INFORMATION

The thermally enhanced package provided with the DRV8332 is designed to interface directly to heat sink using a thermal interface compound in between, (e.g., Ceramique from Arctic Silver, TIMTronics 413, etc.). The heat sink then absorbs heat from the ICs and couples it to the local air.

$R_{\theta JA}$ is a system thermal resistance from junction to ambient air. As such, it is a system parameter with the following components:

- $R_{\theta JC}$ (the thermal resistance from junction to case, or in this example the power pad or heat slug)
- Thermal grease thermal resistance
- Heat sink thermal resistance

The thermal grease thermal resistance can be calculated from the exposed power pad or heat slug area and the thermal grease manufacturer's area thermal resistance (expressed in $^{\circ}\text{C}\text{-in}^2/\text{W}$ or $^{\circ}\text{C}\text{-mm}^2/\text{W}$). The approximate exposed heat slug size is as follows:

- DRV8332, 44-pin DDV 0.055 in^2 (35.6 mm^2)

The thermal resistance of a thermal pad is considered higher than a thin thermal grease layer and is not recommended. Thermal tape has an even higher thermal resistance and should not be used at all. Heat sink thermal resistance is predicted by the heat sink vendor, modeled using a continuous flow dynamics (CFD) model, or measured.

Thus the system $R_{\theta JA} = R_{\theta JC} + \text{thermal grease resistance} + \text{heat sink resistance}$.

See the TI application report, *IC Package Thermal Metrics* ([SPRA953A](#)), for more thermal information.

REVISION HISTORY

Changes from Revision A (September 2013) to Revision B	Page
• Changed Overcurrent (OC) Protection section	12
• Deleted Overtemperature Protection section	13

PACKAGING INFORMATION

Orderable part number	Status (1)	Material type (2)	Package Pins	Package qty Carrier	RoHS (3)	Lead finish/ Ball material (4)	MSL rating/ Peak reflow (5)	Op temp (°C)	Part marking (6)
DRV8332HDDV	Active	Production	HTSSOP (DDV) 44	35 TUBE	Yes	NIPDAU	Level-3-260C-168 HR	-55 to 175	DRV8332H
DRV8332HDDV.A	Active	Production	HTSSOP (DDV) 44	35 TUBE	Yes	NIPDAU	Level-3-260C-168 HR	-55 to 175	DRV8332H
DRV8332HDDVG4.A	Active	Production	HTSSOP (DDV) 44	35 TUBE	Yes	NIPDAU	Level-3-260C-168 HR	-55 to 175	DRV8332H

(1) **Status:** For more details on status, see our [product life cycle](#).

(2) **Material type:** When designated, preproduction parts are prototypes/experimental devices, and are not yet approved or released for full production. Testing and final process, including without limitation quality assurance, reliability performance testing, and/or process qualification, may not yet be complete, and this item is subject to further changes or possible discontinuation. If available for ordering, purchases will be subject to an additional waiver at checkout, and are intended for early internal evaluation purposes only. These items are sold without warranties of any kind.

(3) **RoHS values:** Yes, No, RoHS Exempt. See the [TI RoHS Statement](#) for additional information and value definition.

(4) **Lead finish/Ball material:** Parts may have multiple material finish options. Finish options are separated by a vertical ruled line. Lead finish/Ball material values may wrap to two lines if the finish value exceeds the maximum column width.

(5) **MSL rating/Peak reflow:** The moisture sensitivity level ratings and peak solder (reflow) temperatures. In the event that a part has multiple moisture sensitivity ratings, only the lowest level per JEDEC standards is shown. Refer to the shipping label for the actual reflow temperature that will be used to mount the part to the printed circuit board.

(6) **Part marking:** There may be an additional marking, which relates to the logo, the lot trace code information, or the environmental category of the part.

Multiple part markings will be inside parentheses. Only one part marking contained in parentheses and separated by a "-" will appear on a part. If a line is indented then it is a continuation of the previous line and the two combined represent the entire part marking for that device.

Important Information and Disclaimer: The information provided on this page represents TI's knowledge and belief as of the date that it is provided. TI bases its knowledge and belief on information provided by third parties, and makes no representation or warranty as to the accuracy of such information. Efforts are underway to better integrate information from third parties. TI has taken and continues to take reasonable steps to provide representative and accurate information but may not have conducted destructive testing or chemical analysis on incoming materials and chemicals. TI and TI suppliers consider certain information to be proprietary, and thus CAS numbers and other limited information may not be available for release.

In no event shall TI's liability arising out of such information exceed the total purchase price of the TI part(s) at issue in this document sold by TI to Customer on an annual basis.

OTHER QUALIFIED VERSIONS OF DRV8332-HT :

- Catalog : [DRV8332](#)

NOTE: Qualified Version Definitions:

- Catalog - TI's standard catalog product

TUBE

*All dimensions are nominal

Device	Package Name	Package Type	Pins	SPQ	L (mm)	W (mm)	T (μm)	B (mm)
DRV8332HDDV	DDV	HTSSOP	44	35	530	11.89	3600	4.9
DRV8332HDDV.A	DDV	HTSSOP	44	35	530	11.89	3600	4.9
DRV8332HDDVG4.A	DDV	HTSSOP	44	35	530	11.89	3600	4.9

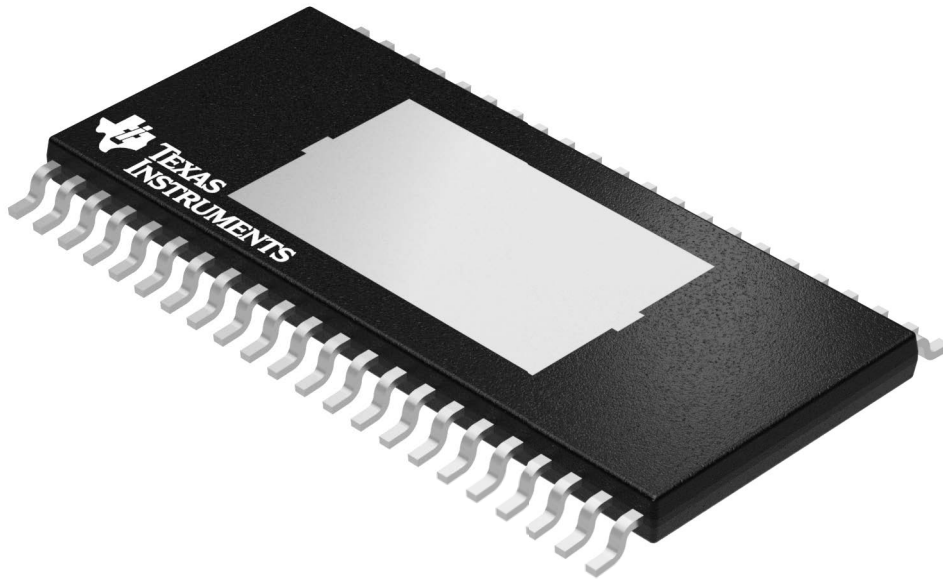

Images above are just a representation of the package family, actual package may vary.
Refer to the product data sheet for package details.

MECHANICAL DATA

DDV (R-PDSO-G44) PowerPAD™ PLASTIC SMALL OUTLINE PACKAGE (DIE DOWN)

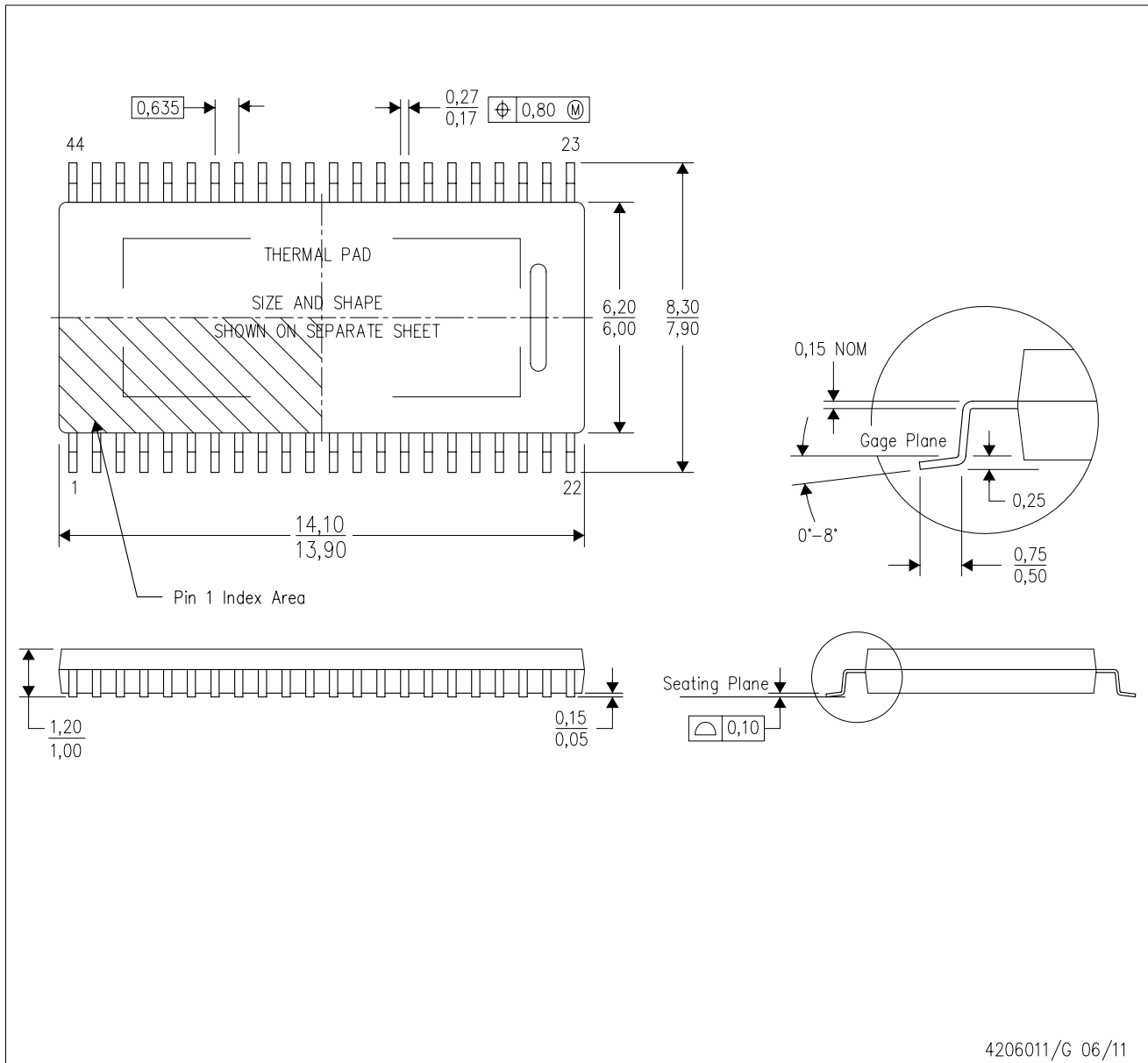

4206011/G 06/11

- NOTES:
- All linear dimensions are in millimeters. Dimensioning and tolerancing per ASME Y14.5M-1994.
 - This drawing is subject to change without notice.
 - Body dimensions do not include mold flash or protrusion not to exceed 0,15.
 - This package is designed to be attached directly to an external heatsink. Refer to Technical Brief, PowerPad Thermally Enhanced Package, Texas Instruments Literature No. SLMA002 for information regarding recommended board layout. This document is available at www.ti.com <<http://www.ti.com>>. See the product data sheet for details regarding the exposed thermal pad dimensions.

PowerPAD is a trademark of Texas Instruments.

THERMAL PAD MECHANICAL DATA

DDV (R-PDSO-G44)

PowerPAD™ SMALL OUTLINE PACKAGE

THERMAL INFORMATION

This PowerPAD™ package incorporates an exposed thermal pad that is designed to be attached directly to an external heatsink. This design optimizes the heat transfer from the integrated circuit (IC).

For additional information on the PowerPAD package and how to take advantage of its heat dissipating abilities, refer to Technical Brief, PowerPAD Thermally Enhanced Package, Texas Instruments Literature No. SLMA002 and Application Brief, PowerPAD Made Easy, Texas Instruments Literature No. SLMA004. Both documents are available at www.ti.com.

The exposed thermal pad dimensions for this package are shown in the following illustration.

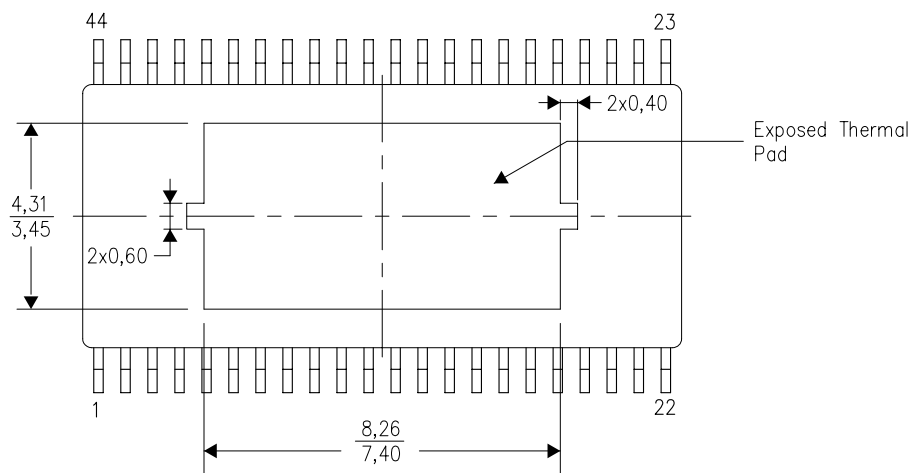

Top View

Exposed Thermal Pad Dimensions

4206975-4/D 07/11

NOTE: All linear dimensions are in millimeters

PowerPAD is a trademark of Texas Instruments

IMPORTANT NOTICE AND DISCLAIMER

TI PROVIDES TECHNICAL AND RELIABILITY DATA (INCLUDING DATA SHEETS), DESIGN RESOURCES (INCLUDING REFERENCE DESIGNS), APPLICATION OR OTHER DESIGN ADVICE, WEB TOOLS, SAFETY INFORMATION, AND OTHER RESOURCES "AS IS" AND WITH ALL FAULTS, AND DISCLAIMS ALL WARRANTIES, EXPRESS AND IMPLIED, INCLUDING WITHOUT LIMITATION ANY IMPLIED WARRANTIES OF MERCHANTABILITY, FITNESS FOR A PARTICULAR PURPOSE OR NON-INFRINGEMENT OF THIRD PARTY INTELLECTUAL PROPERTY RIGHTS.

These resources are intended for skilled developers designing with TI products. You are solely responsible for (1) selecting the appropriate TI products for your application, (2) designing, validating and testing your application, and (3) ensuring your application meets applicable standards, and any other safety, security, regulatory or other requirements.

These resources are subject to change without notice. TI grants you permission to use these resources only for development of an application that uses the TI products described in the resource. Other reproduction and display of these resources is prohibited. No license is granted to any other TI intellectual property right or to any third party intellectual property right. TI disclaims responsibility for, and you will fully indemnify TI and its representatives against, any claims, damages, costs, losses, and liabilities arising out of your use of these resources.

TI's products are provided subject to [TI's Terms of Sale](#) or other applicable terms available either on [ti.com](https://www.ti.com) or provided in conjunction with such TI products. TI's provision of these resources does not expand or otherwise alter TI's applicable warranties or warranty disclaimers for TI products.

TI objects to and rejects any additional or different terms you may have proposed.

Mailing Address: Texas Instruments, Post Office Box 655303, Dallas, Texas 75265

Copyright © 2025, Texas Instruments Incorporated