

TXG402x 2-bit, ±40V Ground-Level Translator

1 Features

- Supports DC shifts up to ±40V
- AC Noise Rejection of 80V_{PP} up to 5MHz
- CMTI of 1kV/μs
- Low Prop Delay (<5ns) and Ch-Ch Skew (<0.20ns)
- Greater than 250Mbps
- Low power consumption (0.8mA per channel at 1Mbps, 1.8V)
- Fully configurable dual-rail design allows each port to operate from 1.71V to 5.5V
- 4, 2, 1 channel devices with multiple configurations will be available
- Two device variants:
 - TXG4020: 2 forward
 - TXG4021: 1 forward, 1 reverse
- Supports V_{CC} disconnect feature (I/Os are forced into high-Z)
- Schmitt-trigger inputs allows for slow and noisy signals
- Inputs with integrated static pull-down resistors prevent channels from floating
- Operating temperature from –40°C to +125°C
- Latch-up performance exceeds 100mA per JESD 78, class II
 - ESD protection exceeds JESD 22
 - 2500V human-body model
 - 500V charged-device model
- Package options provided:
 - DSG (WSON-8)
 - DDF (SOT-8)
 - D (SOIC-8)

2 Applications

- [Test and Measurement](#)
- [Industrial Automation](#)
- [Appliances](#)
- [Robotics](#)
- [Avionics](#)

3 Description

The TXG402x is a 2-bit, fixed direction, non-galvanic based voltage and ground-level translator that can support both logic-level shifting between 1.71V to 5.5V and ground-level shifting up to ±40V. Compared to traditional level shifters, the TXG402x family can solve the challenges of voltage translation across different ground levels. The [Simplified Diagram](#) shows a common use case where DC shift occurs between GNDA to GNDB due to parasitic resistance or capacitance.

V_{CCA} is referenced to GNDA and V_{CCB} is referenced to GNDB. Ax pins are referenced to V_{CCA} logic level while Bx pins are referenced to V_{CCB} logic levels. Both A port and B port can accept voltages from 1.71V to 5.5V. The leakage between GNDA and GNDB is <90nA when V_{CC} to GND is shorted.

The TXG402x device helps improve noise immunity and power sequencing across different ground domains while providing low power consumption, latency and channel-to-channel skew. It can suppress noise levels of 80V_{PP} up to 5MHz ([Figure 7-4](#)). This device can support multiple interfaces such as UART, GPIO, and JTAG.

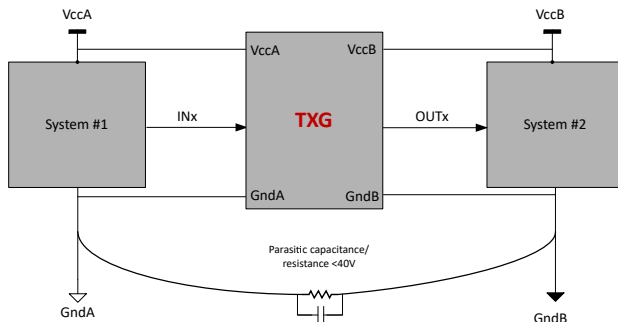

Simplified Diagram

Package Information

PART NUMBER	PACKAGE ⁽¹⁾	BODY SIZE (NOM)
TXG4020 TXG4021	DSG (WSON-8)	2.0mm × 2.00mm
	DDF (SOT-8)	2.90mm × 1.60mm
	D (SOIC-8)	4.90mm × 3.90mm

- (1) For all available packages, see the orderable addendum at the end of the data sheet.



Table of Contents

1 Features	1	7.2 Functional Block Diagram.....	21
2 Applications	1	7.3 Feature Description.....	22
3 Description	1	8 Application and Implementation	25
4 Pin Configuration and Functions	3	8.1 Application Information.....	25
5 Specifications	7	8.2 Typical Application.....	25
5.1 Absolute Maximum Ratings.....	7	8.3 Power Supply Recommendations.....	27
5.2 ESD Ratings.....	7	8.4 Layout.....	27
5.3 Recommended Operating Conditions.....	8	9 Device and Documentation Support	28
5.4 Electrical Characteristics.....	9	9.1 Device Support.....	28
5.5 Switching Characteristics, $V_{CCA} = 1.8 \pm 0.15V$	13	9.2 Documentation Support.....	28
5.6 Switching Characteristics, $V_{CCA} = 2.5 \pm 0.2V$	14	9.3 Receiving Notification of Documentation Updates...28	
5.7 Switching Characteristics, $V_{CCA} = 3.3 \pm 0.3V$	15	9.4 Support Resources.....	28
5.8 Switching Characteristics, $V_{CCA} = 5.0 \pm 0.5V$	16	9.5 Trademarks.....	28
5.9 Switching Characteristics: T_{sk}, T_{MAX}	17	9.6 Electrostatic Discharge Caution.....	28
6 Parameter Measurement Information	19	9.7 Glossary.....	28
6.1 Load Circuit and Voltage Waveforms.....	19	10 Revision History	28
7 Detailed Description	21	11 Mechanical, Packaging, and Orderable Information	28
7.1 Overview.....	21		

4 Pin Configuration and Functions

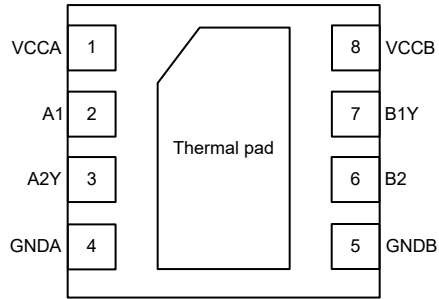

Figure 4-1. TXGx021DSG Package 8-Pin WSON Top View

Table 4-1. TXGx021 DSG Pin Functions

PIN		I/O	DESCRIPTION
Name	TXGx021		
A1	2	I	Input A1. Referenced to V_{CCA}
A2Y	3	O	Output A2. Referenced to V_{CCA}
B1Y	7	O	Output B1. Referenced to V_{CCB}
B2	6	I	Input B2. Referenced to V_{CCB}
V_{CCA}	1	—	A side supply voltage. $1.71V \leq V_{CCA} \leq 5.5V$
V_{CCB}	8	—	B side supply voltage. $1.71V \leq V_{CCB} \leq 5.5V$
GNDA	4	—	Ground reference for V_{CCA}
GNDB	5	—	Ground reference for V_{CCB}
—	Thermal pad	—	Keep thermal pad floating.

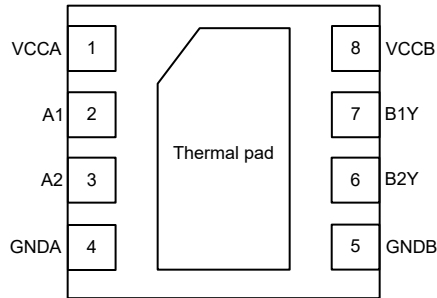

Figure 4-2. TXGx020DSG Package 8-Pin WSON Top View

Table 4-2. TXGx020 DSG Pin Functions

PIN		I/O	DESCRIPTION
Name	TXGx020		
A1	2	I	Input A1. Referenced to V_{CCA}
A2	3	I	Input A2. Referenced to V_{CCA}
B1Y	7	O	Output B1. Referenced to V_{CCB}
B2Y	6	O	Output B2. Referenced to V_{CCB}
V_{CCA}	1	—	A side supply voltage. $1.71V \leq V_{CCA} \leq 5.5V$
V_{CCB}	8	—	B side supply voltage. $1.71V \leq V_{CCB} \leq 5.5V$
GNDA	4	—	Ground reference for V_{CCA}
GNDB	5	—	Ground reference for V_{CCB}
—	Thermal pad	—	Keep thermal pad floating.

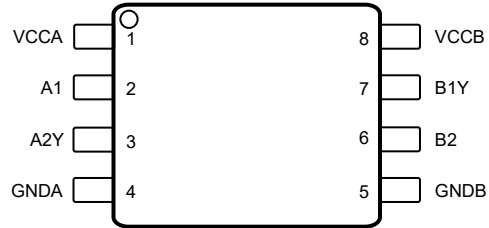

Figure 4-3. TXGx021DDF 8-Pin SOT and TXGx021D 8-pin SOIC Top View

Table 4-3. TXGx021 DDF and D Pin Functions

PIN		I/O	DESCRIPTION
Name	TXGx021		
A1	2	I	Input A1. Referenced to V_{CCA}
A2Y	3	O	Output A2. Referenced to V_{CCA}
B1Y	7	O	Output B1. Referenced to V_{CCB}
B2	6	I	Input B2. Referenced to V_{CCB}
V_{CCA}	1	—	A side supply voltage. $1.71V \leq V_{CCA} \leq 5.5V$
V_{CCB}	8	—	B side supply voltage. $1.71V \leq V_{CCB} \leq 5.5V$
GNDA	4	—	Ground reference for V_{CCA}
GNDB	5	—	Ground reference for V_{CCB}

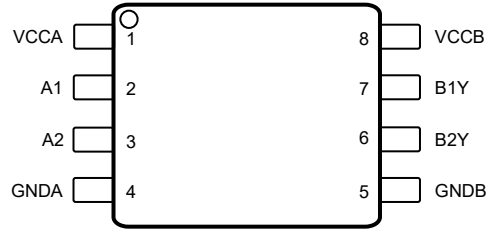

Figure 4-4. TXGx020DDF 8-Pin SOT and TXGx020D 8-pin SOIC Top View

Table 4-4. TXGx020 DDF and D Pin Functions

PIN		I/O	DESCRIPTION
Name	TXGx020		
A1	2	I	Input A1. Referenced to V_{CCA}
A2	3	I	Input A2. Referenced to V_{CCA}
B1Y	7	O	Output B1. Referenced to V_{CCB}
B2Y	6	O	Output B2. Referenced to V_{CCB}
V_{CCA}	1	—	A side supply voltage. $1.71V \leq V_{CCA} \leq 5.5V$
V_{CCB}	8	—	B side supply voltage. $1.71V \leq V_{CCB} \leq 5.5V$
GNDA	4	—	Ground reference for V_{CCA}
GNDB	5	—	Ground reference for V_{CCB}

ADVANCE INFORMATION

5 Specifications

5.1 Absolute Maximum Ratings

over operating free-air temperature range (unless otherwise noted)⁽¹⁾

			MIN	MAX	UNIT
V_{CCA} to V_{GNDA}	Supply voltage A to Ground voltage A		-0.5	6.5	V
V_{CCB} to V_{GNDB}	Supply voltage B to Ground voltage B		-0.5	6.5	V
V_{GNDA} to V_{GNDB}	Voltage between GNDA and GNDB	Voltage between GNDA and GNDB	-45	45	V
V_I	Input Voltage ⁽²⁾	I/O Ports (A Port) to V_{GNDA}	-0.5	6.5	V
		I/O Ports (B Port) to V_{GNDB}	-0.5	6.5	
V_O	Voltage applied to any output in the high-impedance or power-off state ⁽²⁾	A Port to V_{GNDA}	-0.5	6.5	V
		B Port to V_{GNDB}	-0.5	6.5	
V_O	Voltage applied to any output in the high or low state ⁽²⁾ (3)	A Port to V_{GNDA}	-0.5	$V_{CCA} + 0.5$	V
		B Port to V_{GNDB}	-0.5	$V_{CCB} + 0.5$	
I_{IK}	Input clamp current	$V_I < 0$	-20		mA
I_{OK}	Output clamp current	$V_O < 0$	-20		mA
I_O	Continuous output current		-25	25	mA
	Continuous current through V_{CC} or GND		-100	100	mA
T_j	Junction Temperature			150	°C
T_{stg}	Storage temperature		-65	150	°C

- (1) Stresses beyond those listed under [Section 5.1](#) may cause permanent damage to the device. These are stress ratings only, which do not imply functional operation of the device at these or any other conditions beyond those indicated under [Section 5.3](#). Exposure beyond the limits listed in [Section 5.3](#) may affect device reliability.
- (2) The input voltage and output negative-voltage ratings may be exceeded if the input and output current ratings are observed.
- (3) The output positive-voltage rating may be exceeded up to 6.5V maximum if the output current rating is observed.

5.2 ESD Ratings

			VALUE	UNIT
$V_{(ESD)}$	Electrostatic discharge	Human body model (HBM), per ANSI/ESDA/JEDEC JS-001 ⁽¹⁾	±2500	V
		Charged device model (CDM), per ANSI/ESDA/JEDEC JS-002 ⁽²⁾	±500	

- (1) JEDEC document JEP155 states that 500V HBM allows safe manufacturing with a standard ESD control process.
- (2) JEDEC document JEP157 states that 250V CDM allows safe manufacturing with a standard ESD control process.

5.3 Recommended Operating Conditions

over operating free-air temperature range (unless otherwise noted) ⁽¹⁾ ⁽²⁾ ⁽³⁾

			MIN	TYP	MAX	UNIT
V _{CCA}	Supply voltage A - Relative to GNDA		1.71		5.5	V
V _{CCB}	Supply voltage B - Relative to GNDB		1.71		5.5	V
V _{GNDA to GNDB}	Voltage between GNDA and GNDB	Voltage between GNDA and GNDB	Voltage between GNDA and GNDB		40	V
I _{OH}	High-level output current		V _{CCO} = 1.71V	-4.5		mA
			V _{CCO} = 2.3V	-8		
			V _{CCO} = 3V	-10		
			V _{CCO} = 4.5V	-12		
I _{OL}	Low-level output current		V _{CCO} = 1.71V		4.5	mA
			V _{CCO} = 2.3V		8	
			V _{CCO} = 3V		10	
			V _{CCO} = 4.5V		12	
V _I	Input voltage - Relative to GNDA		0		5.5	V
V _O	Output voltage - Relative to GNDB		0		V _{CCO}	V
T _A	Operating free-air temperature		-40		125	°C

- (1) V_{CCI} is the V_{CC} associated with the input port.
- (2) V_{CCO} is the V_{CC} associated with the output port.
- (3) All control inputs and data I/Os of this device have weak pulldowns to ensure the line is not floating when undefined external to the device. The input leakage from these weak pulldowns is defined by the I_I specification indicated under [Section 5.4](#).

5.4 Electrical Characteristics

over operating free-air temperature range (unless otherwise noted)^{(1) (2)}

PARAMETER		TEST CONDITIONS	V _{CCA}	V _{CCB}	Operating free-air temperature (T _A)			UNIT
					–40°C to 125°C			
					MIN	TYP	MAX	
V _{OH}	High-level output voltage ⁽³⁾	I _{OH} = –4.5mA	1.71V	1.71V	1.5			V
		I _{OH} = –8mA	2.3V	2.3V	2.0			
		I _{OH} = –10mA	3V	3V	2.7			
		I _{OH} = –12mA	4.5V	4.5V	4.1			
V _{OL}	Low-level output voltage ⁽⁴⁾	I _{OL} = 4.5mA	1.71V	1.71V	0.16			V
		I _{OL} = 8mA	2.3V	2.3V	0.27			
		I _{OL} = 10mA	3V	3V	0.34			
		I _{OL} = 12mA	4.5V	4.5V	0.41			
V _{T+}	Positive-going input-threshold voltage	Data Inputs (Ax, Bx) (Referenced to V _{CCI})	1.71V	1.71V	1.11			V
			2.3V	2.3V	1.40			
			3V	3V	1.73			
			4.5V	4.5V	2.45			
			5.5V	5.5V	3.0			
V _{T-}	Negative-going input-threshold voltage	Data Inputs (Ax, Bx) (Referenced to V _{CCI})	1.71V	1.71V	0.56			V
			2.3V	2.3V	0.80			
			3V	3V	1.14			
			4.5V	4.5V	1.59			
			5.5V	5.5V	2.0			
ΔV _T	Input-threshold hysteresis (V _{T+} – V _{T-})	Data Inputs (Ax, Bx) (Referenced to V _{CCI})	1.71V	1.71V	0.3		0.55	V
			2.3V	2.3V	0.36		0.60	
			3V	3V	0.38		0.54	
			4.5V	4.5V	0.41		0.86	
ΔV _T	Input-threshold hysteresis (V _{T+} – V _{T-})	Data Inputs (Ax, Bx) (Referenced to V _{CCI})	5.5V	5.5V	0.40		0.96	V
I _I	Input leakage current	Data Inputs (Ax, Bx) V _I = V _{CCI} or GND	1.71V – 5.5V	1.71V – 5.5V	0.2		1.6	μA
I _{off-float}	Floating supply Partial power down current	A Port or B Port V _I = V _{CC}	Floating ⁽⁵⁾	0V - 5.5V	0.26		1.55	μA
			0V - 5.5V	Floating ⁽⁵⁾	0.26		1.55	

over operating free-air temperature range (unless otherwise noted)^{(1) (2)}

PARAMETER		TEST CONDITIONS	V _{CCA}	V _{CCB}	Operating free-air temperature (T _A)			UNIT
					–40°C to 125°C			
					MIN	TYP	MAX	
I _{off-float}	Floating supply Partial power down current	A Port or B Port V _I = GND	Floating ⁽⁵⁾	0V - 5.5V	TBD		TBD	μA
I _{off-float}	Floating supply Partial power down current	A Port or B Port V _I = GND	0V - 5.5V	Floating ⁽⁵⁾	TBD		TBD	μA
C _i	Control Input Capacitance	V _I = 3.3V or V _{GND A}	3.3V	3.3V			2	pF
C _{io}	Data I/O Capacitance	V _O = 1.71V DC +1MHz -16dBm sine wave	3.3V	3.3V	1.3		2.6	pF
C _{GND}	Cap between grounds	All channels combined (V _{CC} both sides are powered on)					46	pF
		All channels combined (V _{CC} to GND shorted)					53	pF
Leakage	Current Leakage between GndA to GndB	All channels combined (V _{CC} both sides are powered on and inputs are all low)	1.71V – 5.5V	1.71V – 5.5V			0.13	μA
		All channels combined (V _{CC} both sides are powered on and inputs are all high)	1.71V – 5.5V	1.71V – 5.5V			32	μA
		All channels combined (V _{CC} to GND shorted)	1.71V – 5.5V	1.71V – 5.5V			0.09	μA
CMTI	Common Mode Transient Immunity	Input toggling at 100Mbps Ground shift up to 40V	1.71V – 5.5V	1.71V – 5.5V		1		kV/μs
TXGx021								
I _{CCA}	V _{CCA} supply current	V _I = V _{CCi} or GND I _O = 0	1.71V – 5.5V	1.71V – 5.5V	300		747	μA
			0V	5.5V	-2		12.5	
			5.5V	0V	349		589	
		V _I = GND I _O = 0	5.5V	Floating ⁽⁵⁾	347		577	
I _{CCB}	V _{CCB} supply current	V _I = V _{CCi} or GND I _O = 0	1.71V – 5.5V	1.71V – 5.5V	497		1077	μA
			0V	5.5V	546		919	
			5.5V	0V	-2		24.5	
		V _I = GND I _O = 0	Floating ⁽⁵⁾	5.5V	548		919	

over operating free-air temperature range (unless otherwise noted)⁽¹⁾ ⁽²⁾

PARAMETER		TEST CONDITIONS	V _{CCA}	V _{CCB}	Operating free-air temperature (T _A)			UNIT		
					–40°C to 125°C					
					MIN	TYP	MAX			
I _{CCA} + I _{CCB}	Supply Current - DC Signal	V _I = V _{CCI}	1.8V	1.8V	0.7		1.6	mA		
			2.5V	2.5V	0.8		1.6			
			3.3V	3.3V	0.8		1.7			
			5V	5V	0.8		1.9			
		V _I = GND	1.8V	1.8V	0.7		1.6	mA		
			2.5V	2.5V	0.8		1.6			
			3.3V	3.3V	0.8		1.7			
			5V	5V	0.8		1.9			
I _{CCA} + I _{CCB}	Supply Current - AC Signal	All channels switching with square wave clock input; CL = 15pF, 1Mbps	1.8V	1.8V	0.9		1.6	mA		
			2.5V	2.5V	0.9		1.6			
			3.3V	3.3V	0.9		1.7			
			5V	5V	1.1		2			
		All channels switching with square wave clock input; CL = 15pF, 50Mbps	1.8V	1.8V	4.6		6.3	mA		
			2.5V	2.5V	5.5		7.3			
			3.3V	3.3V	6.8		8.2			
			5V	5V	8.7		10.7			
		All channels switching with square wave clock input; CL = 15pF, 100Mbps	1.8V	1.8V	8.5		10.6	mA		
			2.5V	2.5V	10		13			
			3.3V	3.3V	12		14.7			
			5V	5V	16.6		20.2			
		TXGx020								
		I _{CCA}	V _{CCA} supply current	V _I = V _{CCI} or GND I _O = 0	1.71V – 5.5V	1.71V – 5.5V	299		602	μA
					0V	5.5V	-2.5		1.2	μA
					5.5V	0V	302		602	μA
V _I = GND I _O = 0	5.5V			Floating ⁽⁵⁾	299		577	μA		
I _{CCB}	V _{CCB} supply current	V _I = V _{CCI} or GND I _O = 0	1.71V – 5.5V	1.71V – 5.5V	504		1225	μA		
			0V	5.5V	486		906	μA		
			5.5V	0V	-2		24.5	μA		
		V _I = GND I _O = 0	Floating ⁽⁵⁾	5.5V	486		906	μA		

over operating free-air temperature range (unless otherwise noted)^{(1) (2)}

PARAMETER		TEST CONDITIONS	V _{CCA}	V _{CCB}	Operating free-air temperature (T _A)			UNIT
					–40°C to 125°C			
					MIN	TYP	MAX	
I _{CCA} + I _{CCB}	Supply Current - DC Signal	V _I = V _{CCI}	1.8V	1.8V	0.7		1.6	mA
			2.5V	2.5V	0.8		1.6	mA
			3.3V	3.3V	0.8		1.7	mA
			5V	5V	0.8		1.9	mA
		V _I = GND	1.8V	1.8V	0.7		1.6	mA
			2.5V	2.5V	0.8		1.6	mA
			3.3V	3.3V	0.8		1.7	mA
			5V	5V	0.8		1.9	mA
I _{CCA} + I _{CCB}	Supply Current - AC Signal	All channels switching with square wave clock input; CL = 15pF, 1Mbps	1.8V	1.8V	0.9		1.6	mA
			2.5V	2.5V	0.9		1.6	mA
			3.3V	3.3V	0.9		1.7	mA
			5V	5V	1.1		2	mA
		All channels switching with square wave clock input; CL = 15pF, 50Mbps	1.8V	1.8V	4.5		6.3	mA
			2.5V	2.5V	5.5		7.3	mA
			3.3V	3.3V	6.3		8	mA
			5V	5V	8.4		10.7	mA
		All channels switching with square wave clock input; CL = 15pF, 100Mbps	1.8V	1.8V	8.5		10.7	mA
			2.5V	2.5V	10		13	mA
			3.3V	3.3V	12		14.7	mA
			5V	5V	16.6		20.2	mA
V _{UVLO+}	Positive-Going Undervoltage Lockout Voltage	A Supply	1.71V – 5.5V			1.62	V	
		B Supply		1.71V – 5.5V		1.62	V	
V _{UVLO-}	Negative-Going Undervoltage Lockout Voltage	A Supply	1.71V – 5.5V		1.33		V	
		B Supply		1.71V – 5.5V	1.33		V	
V _{UVLO_Hys}	Undervoltage Lockout Hysteresis	A Supply	1.71V – 5.5V		105		mV	
		B Supply		1.71V – 5.5V	105		mV	

- (1) V_{CCI} is the V_{CC} associated with the input port and referenced to GND_A
 (2) V_{CCO} is the V_{CC} associated with the output port and referenced to GND_B
 (3) Tested at V_I = V_{T+(MAX)}
 (4) Tested at V_I = V_{T-(MIN)}

(5) Floating is defined as a node that is both not actively driven by an external device and has leakage not exceeding 10nA

5.5 Switching Characteristics, $V_{CCA} = 1.8 \pm 0.15V$

PARAMETER	TEST CONDITIONS	FROM	TO	TEMPERATURE	B-Port Supply Voltage (V_{CCB})												UNIT
					1.8 ± 0.15V			2.5 ± 0.2V			3.3 ± 0.3V			5.0 ± 0.5V			
					MIN	TYP	MAX	MIN	TYP	MAX	MIN	TYP	MAX	MIN	TYP	MAX	
t_{pd}	Propagation delay	1Mbps all 4 channels toggling	A	B	-40°C to 85°C	2.8	7.3	2.8	7.4	2.8	7.5	2.9	7.8	ns			
			A	B	-40°C to 125°C	2.8	7.6	2.8	7.8	2.8	7.9	2.9	8.3				
			B	A	-40°C to 85°C	2.8	7.3	2.7	5.7	2.6	5.1	2.6	4.8				
			B	A	-40°C to 125°C	2.8	7.7	2.7	6	2.6	5.3	2.6	5.1				
PWD	Pulse width distortion	$ t_{pHl} - t_{pHh} $	A	B	-40°C to 85°C	0.7	1.5	0.6	1.5	0.5	1.4	0.5	1.2	ns			
			A	B	-40°C to 125°C	0.7	1.5	0.6	1.5	0.5	1.4	0.5	1.2				
			B	A	-40°C to 85°C	0.7	1.5	0.6	1.5	0.5	1.4	0.5	1.2				
			B	A	-40°C to 125°C	0.7	1.5	0.6	1.5	0.5	1.4	0.4	1.2				
t_r	Output signal rise time		A	B	-40°C to 85°C	0.5	1.3	0.5	1.35	0.5	1.4	0.5	1.6	ns			
			A	B	-40°C to 125°C	0.5	1.3	0.5	1.4	0.5	1.4	0.5	1.7				
			B	A	-40°C to 85°C	0.5	1.2	0.5	1.3	0.5	1.2	0.5	1.3				
			B	A	-40°C to 125°C	0.5	1.3	0.5	1.4	0.5	1.3	0.5	1.3				
t_f	Output signal fall time		A	B	-40°C to 85°C	0.4	1.3	0.4	1.3	0.4	1.5	0.5	1.7	ns			
			A	B	-40°C to 125°C	0.4	1.5	0.4	1.5	0.4	1.6	0.5	2				
			B	A	-40°C to 85°C	0.4	1.3	0.4	1.4	0.4	1.3	0.4	1.3				
			B	A	-40°C to 125°C	0.4	1.4	0.4	1.45	0.4	1.4	0.4	1.35				
t_{DO}	Default output delay time from input power loss	Measured from the time V_{CC} goes below 1.33V			-40°C to 85°C	6.1	10.6	6.1	10.4	6	10.3	5.9	9.9	μ s			
					-40°C to 125°C	6.1	10.6	6.1	10.4	6	10.3	5.9	9.9				
t_{PU}	Time from ULVO to valid output data				-40°C to 85°C	21.1	64.3	4.3	69.1	4.5	76.6	55.3	99.4	μ s			
					-40°C to 125°C	19.9	64.3	4.3	69.1	4.5	76.6	53.9	99.4				

5.6 Switching Characteristics, $V_{CCA} = 2.5 \pm 0.2V$

PARAMETER	TEST CONDITIONS	FROM	TO	TEMPERATURE	B-Port Supply Voltage (V_{CCB})												UNIT	
					1.8 ± 0.15V			2.5 ± 0.2V			3.3 ± 0.3V			5.0 ± 0.5V				
					MIN	TYP	MAX	MIN	TYP	MAX	MIN	TYP	MAX	MIN	TYP	MAX		
t_{pd}	Propagation delay	1Mbps all 4 channels toggling	A	B	-40°C to 85°C	2.7		5.7	2.7		5.8	2.7		5.9	2.8		6.3	ns
			A	B	-40°C to 125°C	2.7		6	2.7		6.1	2.7		6.2	2.8		6.6	
			B	A	-40°C to 85°C	2.8		7.4	2.7		5.8	2.6		5.1	2.6		4.9	
			B	A	-40°C to 125°C	2.8		7.7	2.7		6.1	2.6		5.5	2.6		5.2	
PWD	Pulse width distortion	$ t_{pH} - t_{pL} $	A	B	-40°C to 85°C	0.1		1	0.1		0.8	0		0.7	-0.14		0.6	ns
			A	B	-40°C to 125°C	0.1		1	0.1		0.8	0		0.7	-0.15		0.6	
			B	A	-40°C to 85°C	0.1		1	0.1		0.8	0		0.7	-0.14		0.6	
			B	A	-40°C to 125°C	0.1		1	0.1		0.8	0		0.7	-0.15		0.6	
t_r	Output signal rise time		A	B	-40°C to 85°C	0.5		1.3	0.5		1.3	0.5		1.4	0.5		1.6	ns
			A	B	-40°C to 125°C	0.5		1.3	0.5		1.4	0.5		1.4	0.5		1.7	
			B	A	-40°C to 85°C	0.5		1.3	0.4		1.3	0.5		1.3	0.4		1.3	
			B	A	-40°C to 125°C	0.5		1.3	0.4		1.3	0.5		1.3	0.4		1.4	
t_f	Output signal fall time		A	B	-40°C to 85°C	0.4		1.4	0.4		1.3	0.4		1.5	0.5		1.7	ns
			A	B	-40°C to 125°C	0.4		1.4	0.4		1.5	0.4		1.6	0.5		2	
			B	A	-40°C to 85°C	0.4		1.3	0.4		1.3	0.4		1.35	0.4		1.3	
			B	A	-40°C to 125°C	0.4		1.5	0.4		1.5	0.4		1.4	0.4		1.5	
t_{DO}	Default output delay time from input power loss	Measured from the time V_{CC} goes below 1.33V			-40°C to 85°C	6.1		10.6	6.1		10.4	5.6		10.4	5.4		9.9	μs
					-40°C to 125°C	6.1		10.6	6.1		10.4	5.6		10.4	5.4		9.9	
t_{PU}	Time from ULVO to valid output data				-40°C to 85°C	21.1		64.3	4.3		69.1	4.5		76.6	55.3		99.4	μs
					-40°C to 125°C	19.9		64.3	4.3		69.1	4.5		76.6	53.9		99.4	

5.7 Switching Characteristics, $V_{CCA} = 3.3 \pm 0.3V$

PARAMETER	TEST CONDITIONS	FROM	TO	TEMPERATURE	B-Port Supply Voltage (V_{CCB})												UNIT
					1.8 ± 0.15V			2.5 ± 0.2V			3.3 ± 0.3V			5.0 ± 0.5V			
					MIN	TYP	MAX	MIN	TYP	MAX	MIN	TYP	MAX	MIN	TYP	MAX	
t_{pd}	Propagation delay	1Mbps all 4 channels toggling	A	B	-40°C to 85°C	2.6	5.1	2.7	5.2	2.7	5.3	2.8	5.8	ns			
			A	B	-40°C to 125°C	2.6	5.3	2.7	5.5	2.7	5.7	2.8	6.3				
			B	A	-40°C to 85°C	2.8	7.5	2.7	5.9	2.7	5.3	2.6	5.1				
			B	A	-40°C to 125°C	2.8	7.9	2.7	6.2	2.7	5.7	2.6	5.4				
PWD	Pulse width distortion	$ t_{pHl} - t_{pHh} $	A	B	-40°C to 85°C	-0.03	0.6	-0.09	0.5	-0.13	0.5	-0.3	0.4	ns			
			A	B	-40°C to 125°C	-0.11	0.6	-0.13	0.5	-0.18	0.5	-0.4	0.4				
			B	A	-40°C to 85°C	-0.03	0.6	-0.09	0.5	-0.13	0.5	-0.3	0.4				
			B	A	-40°C to 125°C	-0.11	0.6	-0.13	0.5	-0.18	0.5	-0.4	0.4				
t_r	Output signal rise time		A	B	-40°C to 85°C	0.5	1.3	0.5	1.3	0.5	1.4	0.5	1.6	ns			
			A	B	-40°C to 125°C	0.5	1.3	0.5	1.4	0.5	1.4	0.5	1.6				
			B	A	-40°C to 85°C	0.5	1.3	0.5	1.3	0.5	1.4	0.5	1.4				
			B	A	-40°C to 125°C	0.5	1.35	0.5	1.4	0.5	1.4	0.5	1.5				
t_f	Output signal fall time		A	B	-40°C to 85°C	0.4	1.3	0.4	1.4	0.4	1.5	0.5	1.7	ns			
			A	B	-40°C to 125°C	0.4	1.5	0.4	1.6	0.4	1.6	0.5	2				
			B	A	-40°C to 85°C	0.4	1.4	0.4	1.4	0.4	1.4	0.4	1.4				
			B	A	-40°C to 125°C	0.4	1.7	0.4	1.6	0.4	1.6	0.4	1.7				
t_{DO}	Default output delay time from input power loss	Measured from the time V_{CC} goes below 1.33V			-40°C to 85°C	6	10.6	5.8	10.4	5.8	10.3	5.8	10	μs			
					-40°C to 125°C	6	10.6	5.8	10.4	5.8	10.3	5.8	10	μs			
t_{PU}	Time from ULVO to valid output data			-40°C to 85°C	21.1	64.3	4.3	69.1	4.5	76.6	57.8	99.4	μs				
				-40°C to 125°C	19.9	64.3	4.3	69.1	4.5	76.6	53.9	99.4	μs				

5.8 Switching Characteristics, $V_{CCA} = 5.0 \pm 0.5V$

PARAMETER	TEST CONDITIONS	FROM	TO	TEMPERATURE	B-Port Supply Voltage (V_{CCB})												UNIT
					1.8 ± 0.15V			2.5 ± 0.2V			3.3 ± 0.3V			5.0 ± 0.5V			
					MIN	TYP	MAX	MIN	TYP	MAX	MIN	TYP	MAX	MIN	TYP	MAX	
t_{pd}	Propagation delay	1Mbps all 4 channels toggling	A	B	-40°C to 85°C	2.6	4.8	2.6	5	2.7	5.1	2.8	5.6	ns			
			A	B	-40°C to 125°C	2.6	5.1	2.6	5.3	2.7	5.4	2.8	5.9				
			B	A	-40°C to 85°C	3	7.9	2.8	6.2	2.7	5.9	2.7	5.6				
			B	A	-40°C to 125°C	3	8.4	2.8	6.6	2.7	6.2	2.7	6				
PWD	Pulse width distortion	$ t_{pHl} - t_{pHh} $	A	B	-40°C to 85°C	-0.22	0.4	-0.27	0.3	-0.32	0.3	-0.50	0.2	ns			
			A	B	-40°C to 125°C	-0.33	0.4	-0.37	0.3	-0.42	0.3	-0.60	0.2				
			B	A	-40°C to 85°C	-0.22	0.4	-0.27	0.3	-0.32	0.3	-0.5	0.2				
			B	A	-40°C to 125°C	-0.33	0.4	-0.37	0.3	-0.42	0.3	-0.60	0.2				
t_r	Output signal rise time		A	B	-40°C to 85°C	0.5	1.3	0.5	1.3	0.5	1.4	0.5	1.6	ns			
			A	B	-40°C to 125°C	0.5	1.3	0.5	1.4	0.5	1.4	0.5	1.6				
			B	A	-40°C to 85°C	0.6	1.6	0.6	1.6	0.6	1.6	0.5	1.6				
			B	A	-40°C to 125°C	0.6	1.75	0.6	1.7	0.6	1.7	0.5	1.6				
t_f	Output signal fall time		A	B	-40°C to 85°C	0.4	1.3	0.4	1.4	0.4	1.5	0.5	1.7	ns			
			A	B	-40°C to 125°C	0.4	1.4	0.4	1.5	0.4	1.6	0.5	2				
			B	A	-40°C to 85°C	0.4	1.8	0.5	1.8	0.4	1.8	0.4	1.8				
			B	A	-40°C to 125°C	0.4	2.5	0.5	2	0.4	2	0.4	2				
t_{DO}	Default output delay time from input power loss	Measured from the time V_{CC} goes below 1.33V			-40°C to 85°C	5.5	10.7	5.6	10.5	5.7	10.6	5.9	10	μs			
					-40°C to 125°C	5.5	10.7	5.6	10.5	5.7	10.6	5.9	10				
t_{PU}	Time from ULVO to valid output data				-40°C to 85°C	21.1	64.3	4.3	69.1	4.5	76.6	55.3	99.4	μs			
					-40°C to 125°C	19.9	64.3	4.3	69.1	4.5	76.6	53.9	99.4				

5.9 Switching Characteristics: T_{sk} , T_{MAX}

over operating free-air temperature range (unless otherwise noted)

PARAMETER	TEST CONDITIONS		V_{CCI}	V_{CCO}	Operating free-air temperature (T_A)			UNIT
					-40°C to 125°C			
					MIN	TYP	MAX	
T_{MAX} - Maximum Data Rate	50% Duty Cycle Input One channel switching 20% of pulse > $0.7 \cdot V_{CCO}$ 20% of pulse < $0.3 \cdot V_{CCO}$	No Translation	1.65V - 1.95V	1.65V - 1.95V	264			Mbps
			2.3V - 2.7V	2.3V - 2.7V	220			
			3.0V - 3.6V	3.0V - 3.6V	220			
			4.5V - 5.5V	4.5V - 5.5V	176			
T_{MAX} - Maximum Data Rate	50% Duty Cycle Input One channel switching 20% of pulse > $0.7 \cdot V_{CCO}$ 20% of pulse < $0.3 \cdot V_{CCO}$	Up Translation	1.65V - 1.95V	2.3V - 2.7V	264			Mbps
			1.65V - 1.95V	3.0V - 3.6V	264			
			1.65V - 1.95V	4.5V - 5.5V	264			
			2.3V - 2.7V	3.0V - 3.6V	220			
			2.3V - 2.7V	4.5V - 5.5V	220			
			3.0V - 3.6V	4.5V - 5.5V	176			
T_{MAX} - Maximum Data Rate	50% Duty Cycle Input One channel switching 20% of pulse > $0.7 \cdot V_{CCO}$ 20% of pulse < $0.3 \cdot V_{CCO}$	Down Translation	2.3V - 2.7V	1.65V - 1.95V	264			Mbps
			3.0V - 3.6V	2.3V - 2.7V	220			
			3.0V - 3.6V	1.65V - 1.95V	220			
			4.5V - 5.5V	3.0V - 3.6V	176			
			4.5V - 5.5V	1.65V - 1.95V	220			
			4.5V - 5.5V	1.65V - 1.95V	220			
t_{sk} - Output skew	Timing skew between any switching outputs on the rising or falling edge (same direction channels)	No Translation	1.65V - 1.95V	1.65V - 1.95V	0.02			ns
			2.3V - 2.7V	2.3V - 2.7V	0.02			
			3.0V - 3.6V	3.0V - 3.6V	0.02			
			4.5V - 5.5V	4.5V - 5.5V	0.04			
t_{sk} - Output skew	Timing skew between any switching outputs on the rising or falling edge (same direction channels)	Up Translation	1.65V - 1.95V	2.3V - 2.7V	0.02			ns
			1.65V - 1.95V	3.0V - 3.6V	0.02			
			1.65V - 1.95V	4.5V - 5.5V	0.02			
			2.3V - 2.7V	3.0V - 3.6V	0.02			
			2.3V - 2.7V	4.5V - 5.5V	0.02			
			3.0V - 3.6V	4.5V - 5.5V	0.02			

over operating free-air temperature range (unless otherwise noted)

PARAMETER	TEST CONDITIONS		V _{CCI}	V _{CCO}	Operating free-air temperature (T _A)			UNIT
					-40°C to 125°C			
					MIN	TYP	MAX	
t _{sk} - Output skew	Timing skew between any switching outputs on the rising or falling edge (same direction channels)	Down Translation	2.3V - 2.7V	1.65V - 1.95V			0.02	ns
			3.0V - 3.6V	2.3V - 2.7V			0.02	
			3.0V - 3.6V	1.65V - 1.95V			0.02	
			4.5V - 5.5V	3.0V - 3.6V			0.04	
			4.5V - 5.5V	2.3V - 2.7V			0.04	
			4.5V - 5.5V	1.65V - 1.95V			0.04	

6 Parameter Measurement Information

6.1 Load Circuit and Voltage Waveforms

Unless otherwise noted, generators supply all input pulses that have the following characteristics:

- $f = 1\text{MHz}$
- $Z_O = 50\Omega$
- $\Delta t/\Delta V \leq 1\text{ns/V}$

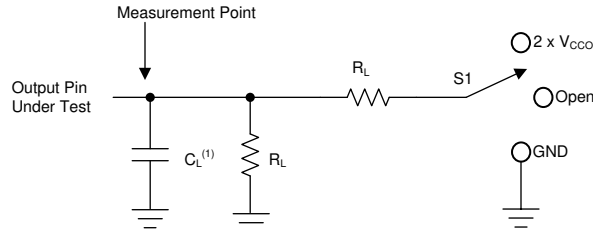

A. C_L includes probe and jig capacitance.

Figure 6-1. Load Circuit

Table 6-1. Load Circuit Conditions

Parameter	V_{CCO}	R_L	C_L	S_1	V_{TP}
t_{pd} Propagation (delay) time	1.71V – 5.5V	10k Ω	15pF	Open	N/A

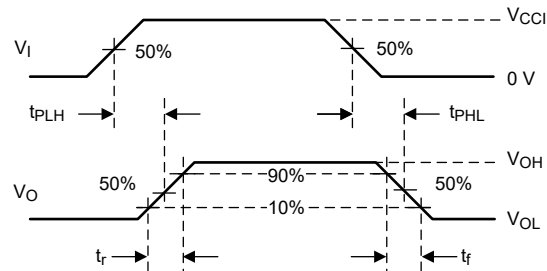

1. V_{CCI} is the supply pin associated with the input port.
2. V_{OH} and V_{OL} are typical output voltage levels that occur with specified R_L , C_L , and S_1

Figure 6-2. Switching Characteristics Voltage Waveforms

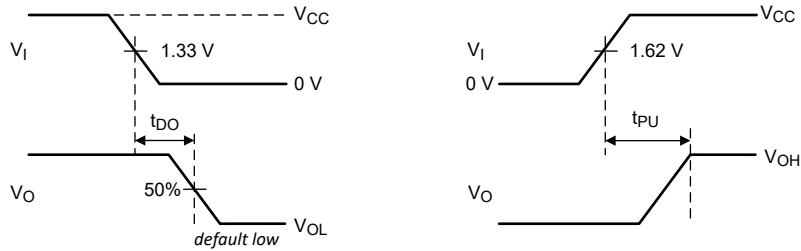

1. V_{CCI} is the supply pin associated with the input port.
2. V_{OH} and V_{OL} are typical output voltage levels that occur with specified R_L , C_L , and S_1

Figure 6-3. Default Output Delay Time & Time from UVLO to Valid Output Voltage Waveform

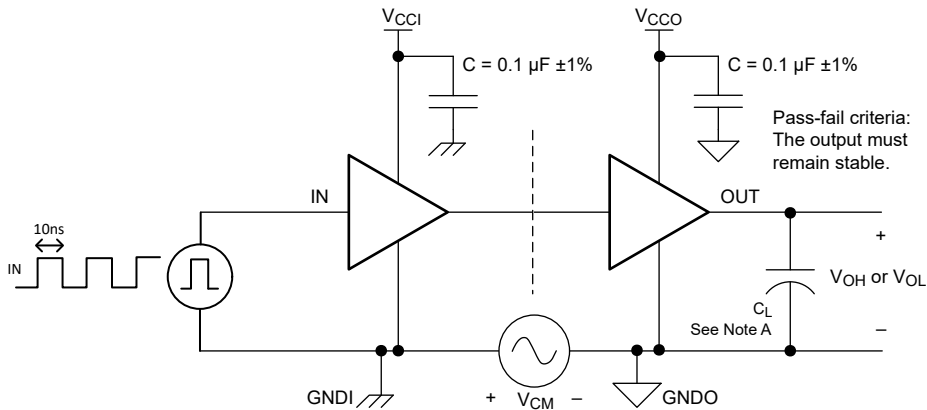

1. $C_L = 15\text{pF}$ and includes instrumentation and fixture capacitance within $\pm 20\%$.

Figure 6-4. Common-Mode Transient Immunity Test Circuit

7 Detailed Description

7.1 Overview

The TXG402x is a 2-bit ground-level translator that uses two individually configurable power-supply rails which allows it to translate across two different power domains. The device is operational with V_{CCA} and V_{CCB} supplies as low as 1.71V and as high as 5.5V. The A port is designed to track V_{CCA} and the B port is designed to track V_{CCB} . In addition to I/O level shifting, this translator can support a difference of -40V to +40V between GNDA and GNDB. V_{CCA} is referenced to GNDA and V_{CCB} is referenced to GNDB.

The TXG402x device is designed for asynchronous communication between data buses, and transmits data with fixed direction from the A bus to the B bus on some channels and from the B bus to the A bus on the remaining channels.

The V_{CC} disconnect feature ensures that if V_{CC} is disconnected with the complementary supply within recommended operating conditions, outputs are disabled and set to the high-impedance state while the supply current is maintained. The $I_{off-float}$ circuitry ensures that no excessive current is drawn from or sourced into an input or output while the supply is floating.

Glitch-free power supply sequencing allows either supply rail to be powered on or off in any order while providing robust power sequencing performance.

7.2 Functional Block Diagram

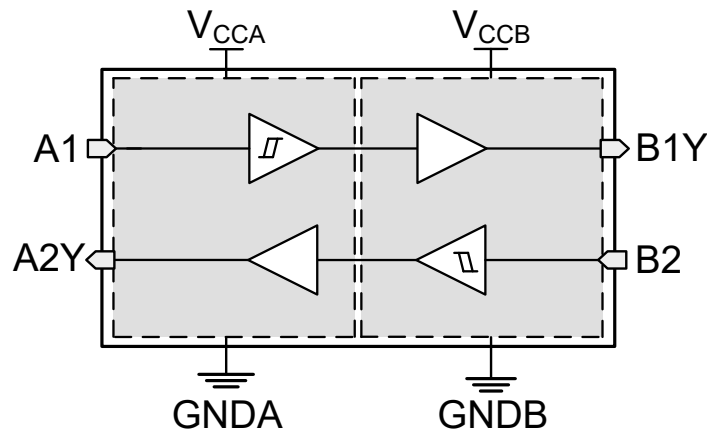

Figure 7-1. TXG4021 Functional Block Diagram

7.3 Feature Description

7.3.1 CMOS Schmitt-Trigger Inputs with Integrated Pulldowns

Standard CMOS inputs are high impedance and are typically modeled as a resistor in parallel with the input capacitance given in the [Section 5.4](#). The worst case resistance is calculated with the maximum input voltage, given in the [Section 5.1](#), and the maximum input leakage current, given in the [Section 5.4](#), using ohm's law ($R = V \div I$).

The Schmitt-trigger input architecture provides hysteresis as defined by ΔV_T in the [Section 5.4](#), which makes this device extremely tolerant to slow or noisy inputs. Driving the inputs slowly will increase dynamic current consumption of the device. See [Understanding Schmitt Triggers](#) for additional information regarding Schmitt-trigger inputs.

7.3.1.1 Inputs with Integrated Static Pull-Down Resistors

This device has 5M Ω typical integrated weak pull-downs for each input. This feature allows all inputs to be left floating without the concern for unstable outputs or increased current consumption. This also helps to reduce external component count for applications where not all channels are used or need to be fixed low. If an external pull-up is required, it should be no larger than 1M Ω to avoid contention with the 5M Ω internal pull-down.

7.3.2 Balanced High-Drive CMOS Push-Pull Outputs

A balanced output allows the device to sink and source similar currents. The high drive capability of this device creates fast edges into light loads, so routing and load conditions should be considered to prevent ringing. Additionally, the outputs of this device are capable of driving larger currents than the device can sustain without being damaged. [Section 5.1](#) defines the electrical and thermal limits that must be followed at all times.

7.3.3 V_{CC} Disconnect

The outputs for this device are disabled and enter a high-impedance state when either supply is left floating (disconnected), and with the complementary supply within recommended operating conditions. It is recommended that the inputs are kept low before floating (disconnecting) either supply.

The $I_{CCx(\text{floating})}$ in the [Section 5.4](#) specifies the maximum supply current. The $I_{\text{off}(\text{float})}$ in the [Section 5.4](#) specifies the maximum leakage into or out of any input or output pin on the device.

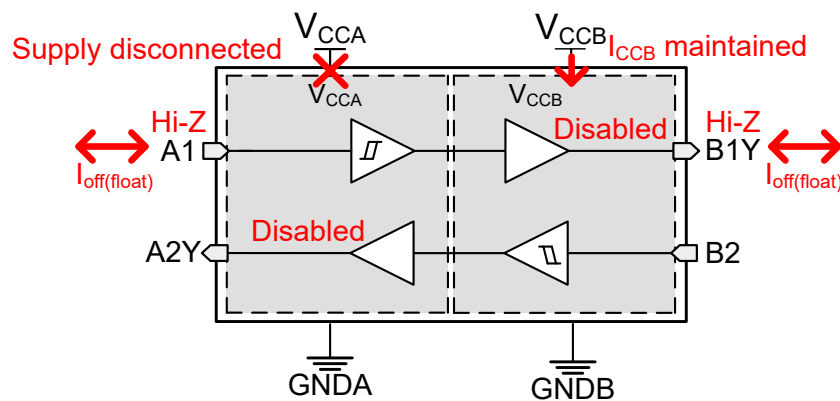

Figure 7-2. V_{CC} Disconnect Feature

7.3.4 Over-Voltage Tolerant Inputs

Input signals to this device can be driven above the supply voltage so long as they remain below the maximum input voltage value specified in the [Section 5.3](#).

7.3.5 Glitch-Free Power Supply Sequencing

Either supply rail may be powered on or off in any order without producing a glitch on the inputs or outputs (that is, where the output erroneously transitions to V_{CC} when it should be held low or vice versa). Glitches of this

nature can be misinterpreted by a peripheral as a valid data bit, which could trigger a false device reset of the peripheral, a false device configuration of the peripheral, or even a false data initialization by the peripheral.

7.3.6 Negative Clamping Diodes

Figure 7-3 depicts the inputs and outputs to this device that have negative clamping diodes.

CAUTION

Voltages beyond the values specified in the [Section 5.1](#) table can cause damage to the device. The input negative-voltage and output voltage ratings may be exceeded if the input and output clamp-current ratings are observed.

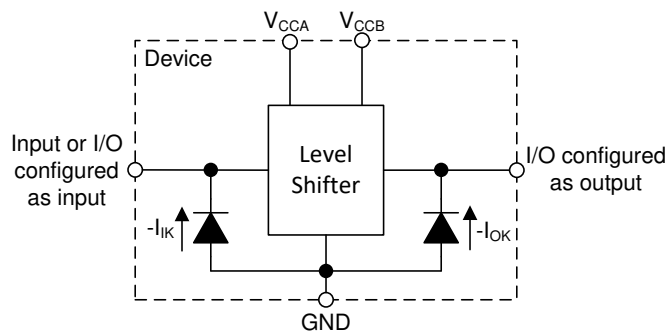

Figure 7-3. Electrical Placement of Clamping Diodes for Each Input and Output

7.3.7 Fully Configurable Dual-Rail Design

The V_{CCA} and V_{CCB} pins can be supplied at any voltage from 1.71V to 5.5V, making the device suitable for translating between any of the voltage nodes (1.8V, 2.5V, 3.3V, and 5.0V).

7.3.8 Supports High-Speed Translation

The TXG402x device can support high data-rate applications. The translated signal data rate can be greater than 250Mbps when the signal is translated from 1.71V to 5.5V.

7.3.9 AC Noise Rejection

TXG402x supports I/O voltage translation in environments with noisy grounds. The plot below illustrates the amount of noise that GNDA and GNDB can reject in terms peak-to-peak voltage over frequency without disrupting communication between two systems. As an example, [Figure 7-5](#) below shows GNDA with a ground bounce of $2V_{PP}$ at 10kHz but still effectively translating 5V to 2.5V without any degradation.

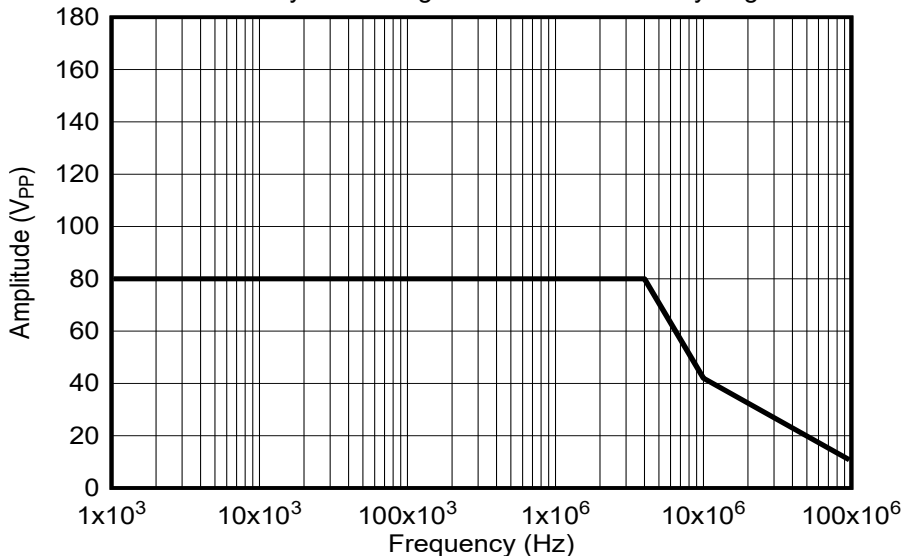
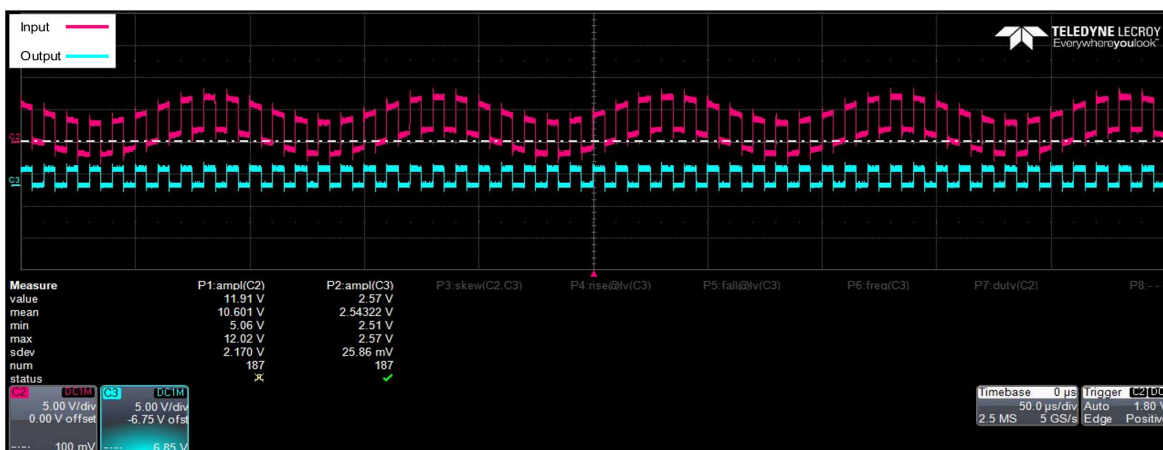

Figure 7-4. AC Noise Rejection Plot

Voltage:
 VCCA = 5V
 VCCB = 2.5V



*Note: Offset voltage on the output to show both signals side-by-side

Figure 7-5. Waveform showing 5V to 2.5V I/O translation with AC Ground Noise of $2V_{PP}$ at 10kHz

8 Application and Implementation

Note

Information in the following applications sections is not part of the TI component specification, and TI does not warrant its accuracy or completeness. TI's customers are responsible for determining suitability of components for their purposes, as well as validating and testing their design implementation to confirm system functionality.

8.1 Application Information

The TXG402x is used for level translation, enabling communication between devices or systems operating at different interface and ground voltages. The TXG402x device is ideal for use in applications where a push-pull driver is connected to the data inputs. [Figure 8-1](#) is an example of two systems that translate from 1.8V to 3.3V across a SPI interface while also seeing a ground shift of -3V on GNDB while GNDA is at 0V. The ground shift of 3V is from the noisy power ground of the Digital-to-Analog Converter (DAC).

8.2 Typical Application

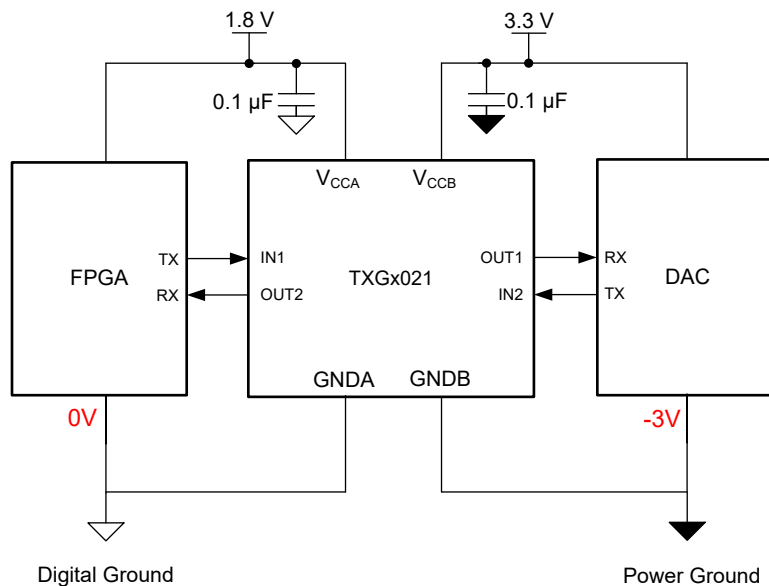

Figure 8-1. TXG4021 in Test and Measurement

8.2.1 Design Requirements

Use the parameters listed in [Table 8-1](#) for this design example.

Table 8-1. Design Parameters

DESIGN PARAMETERS	EXAMPLE VALUES
Input voltage range	1.71V to 5.5V
Output voltage range	1.71V to 5.5V

8.2.2 Detailed Design Procedure

To begin the design process, determine the following:

- Input voltage range
 - Use the supply voltage of the device that is driving the TXG402x device to determine the input voltage range. For a valid logic-high, the value must exceed the positive-going input-threshold voltage (V_{T+}) of the

input port. For a valid logic low the value must be less than the negative-going input-threshold voltage (V_{T-}) of the input port.

- Output voltage range
 - Use the supply voltage of the device that the TXG402x device is driving to determine the output voltage range.

8.2.3 Application Curves

Voltage:
 VCCA = 5V
 VCCB = 2.5V

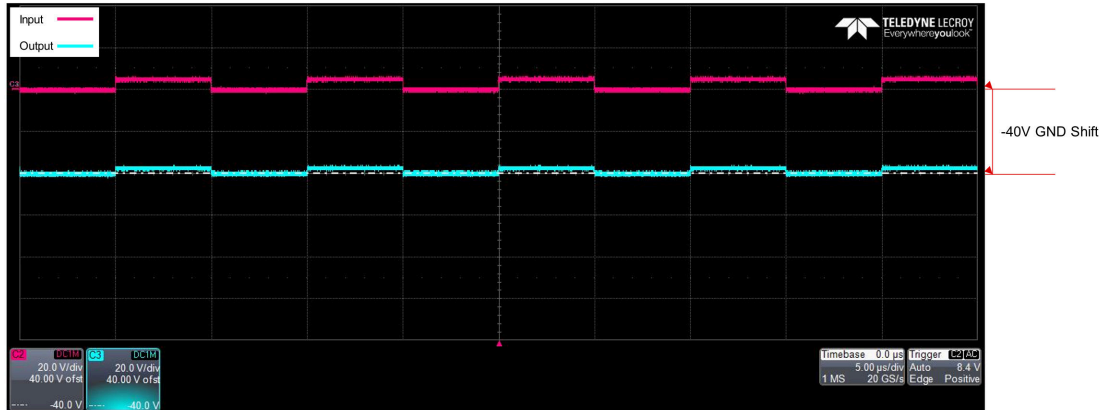

*Note: All signals have a +40V offset to show negative ground shift

Voltage:
 VCCA = 5V
 VCCB = 2.5V

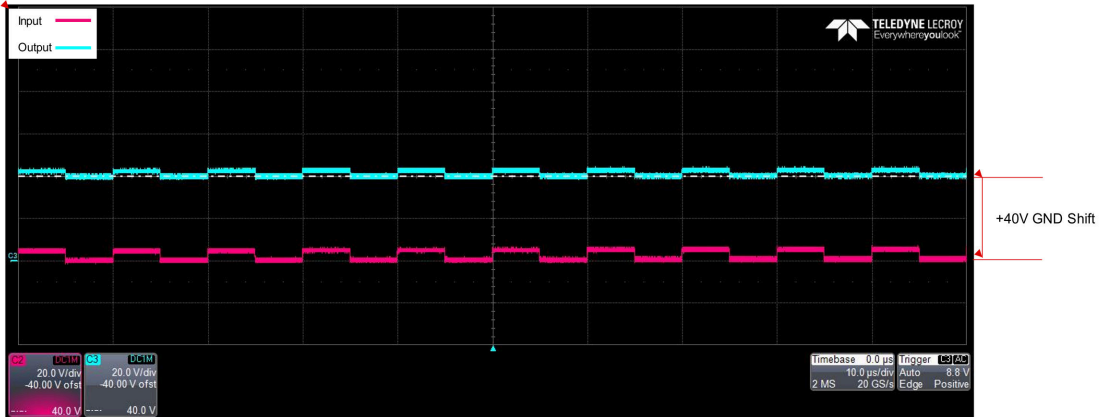

*Note: All signals have a -40V offset to show positive ground shift

Figure 8-2. Waveform showing -40V (top) and +40V (bottom) Ground Shift with 5V to 2.5V I/O Translation

8.3 Power Supply Recommendations

Always apply a ground reference to the GND pins first. This device is designed for glitch free power sequencing without any supply sequencing requirements such as ramp order or ramp rate. Please make sure the difference between V_{CC} and GND remains at 6.5V max at all times.

8.4 Layout

8.4.1 Layout Guidelines

To ensure reliability of the device, following common printed-circuit board layout guidelines are recommended:

- Use bypass capacitors on the power supply pins and place them as close to the device as possible. A 0.1µF capacitor is recommended, but transient performance can be improved by having 1µF and 0.1µF capacitors in parallel as bypass capacitors.
- The high drive capability of this device creates fast edges into light loads so routing and load conditions should be considered to prevent ringing.
- A 0.1µF capacitor can be added between GNDA and GNDB to improve performances of CMTI.

8.4.2 Layout Example

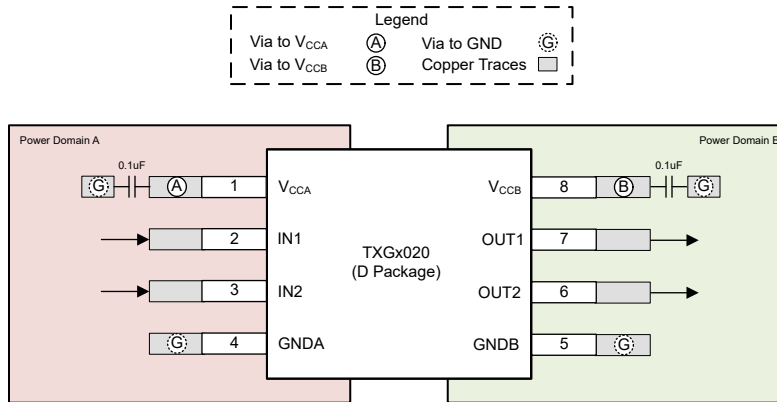

Figure 8-3. D Layout Example

9 Device and Documentation Support

9.1 Device Support

9.1.1 Regulatory Requirements

No statutory or regulatory requirements apply to this device.

There are no special characteristics for this product.

9.2 Documentation Support

9.2.1 Related Documentation

For related documentation, see the following:

- Texas Instruments, [Understanding Schmitt Triggers application report](#)
- Texas Instruments, [CMOS Power Consumption and \$C_{pd}\$ Calculation application report](#)

9.3 Receiving Notification of Documentation Updates

To receive notification of documentation updates, navigate to the device product folder on [ti.com](https://www.ti.com). Click on *Notifications* to register and receive a weekly digest of any product information that has changed. For change details, review the revision history included in any revised document.

9.4 Support Resources

[TI E2E™ support forums](#) are an engineer's go-to source for fast, verified answers and design help — straight from the experts. Search existing answers or ask your own question to get the quick design help you need.

Linked content is provided "AS IS" by the respective contributors. They do not constitute TI specifications and do not necessarily reflect TI's views; see TI's [Terms of Use](#).

9.5 Trademarks

TI E2E™ is a trademark of Texas Instruments.

All trademarks are the property of their respective owners.

9.6 Electrostatic Discharge Caution



This integrated circuit can be damaged by ESD. Texas Instruments recommends that all integrated circuits be handled with appropriate precautions. Failure to observe proper handling and installation procedures can cause damage.

ESD damage can range from subtle performance degradation to complete device failure. Precision integrated circuits may be more susceptible to damage because very small parametric changes could cause the device not to meet its published specifications.

9.7 Glossary

[TI Glossary](#) This glossary lists and explains terms, acronyms, and definitions.

10 Revision History

NOTE: Page numbers for previous revisions may differ from page numbers in the current version.

DATE	REVISION	NOTES
June 2025	*	Initial Release

11 Mechanical, Packaging, and Orderable Information

The following pages include mechanical, packaging, and orderable information. This information is the most current data available for the designated devices. This data is subject to change without notice and revision of this document. For browser-based versions of this data sheet, refer to the left-hand navigation.

PACKAGING INFORMATION

Orderable part number	Status (1)	Material type (2)	Package Pins	Package qty Carrier	RoHS (3)	Lead finish/ Ball material (4)	MSL rating/ Peak reflow (5)	Op temp (°C)	Part marking (6)
PTXG4020DR	Active	Preproduction	SOIC (D) 8	3000 LARGE T&R	-	Call TI	Call TI	-40 to 125	
PTXG4021DR	Active	Preproduction	SOIC (D) 8	3000 LARGE T&R	-	Call TI	Call TI	-40 to 125	

⁽¹⁾ **Status:** For more details on status, see our [product life cycle](#).

⁽²⁾ **Material type:** When designated, preproduction parts are prototypes/experimental devices, and are not yet approved or released for full production. Testing and final process, including without limitation quality assurance, reliability performance testing, and/or process qualification, may not yet be complete, and this item is subject to further changes or possible discontinuation. If available for ordering, purchases will be subject to an additional waiver at checkout, and are intended for early internal evaluation purposes only. These items are sold without warranties of any kind.

⁽³⁾ **RoHS values:** Yes, No, RoHS Exempt. See the [TI RoHS Statement](#) for additional information and value definition.

⁽⁴⁾ **Lead finish/Ball material:** Parts may have multiple material finish options. Finish options are separated by a vertical ruled line. Lead finish/Ball material values may wrap to two lines if the finish value exceeds the maximum column width.

⁽⁵⁾ **MSL rating/Peak reflow:** The moisture sensitivity level ratings and peak solder (reflow) temperatures. In the event that a part has multiple moisture sensitivity ratings, only the lowest level per JEDEC standards is shown. Refer to the shipping label for the actual reflow temperature that will be used to mount the part to the printed circuit board.

⁽⁶⁾ **Part marking:** There may be an additional marking, which relates to the logo, the lot trace code information, or the environmental category of the part.

Multiple part markings will be inside parentheses. Only one part marking contained in parentheses and separated by a "~" will appear on a part. If a line is indented then it is a continuation of the previous line and the two combined represent the entire part marking for that device.

Important Information and Disclaimer:The information provided on this page represents TI's knowledge and belief as of the date that it is provided. TI bases its knowledge and belief on information provided by third parties, and makes no representation or warranty as to the accuracy of such information. Efforts are underway to better integrate information from third parties. TI has taken and continues to take reasonable steps to provide representative and accurate information but may not have conducted destructive testing or chemical analysis on incoming materials and chemicals. TI and TI suppliers consider certain information to be proprietary, and thus CAS numbers and other limited information may not be available for release.

In no event shall TI's liability arising out of such information exceed the total purchase price of the TI part(s) at issue in this document sold by TI to Customer on an annual basis.

OTHER QUALIFIED VERSIONS OF TXG4020, TXG4021 :

- Automotive : [TXG4020-Q1](#), [TXG4021-Q1](#)

NOTE: Qualified Version Definitions:

- Automotive - Q100 devices qualified for high-reliability automotive applications targeting zero defects

EXAMPLE BOARD LAYOUT

D0008A

SOIC - 1.75 mm max height

SMALL OUTLINE INTEGRATED CIRCUIT



LAND PATTERN EXAMPLE
 EXPOSED METAL SHOWN
 SCALE:8X



SOLDER MASK DETAILS

4214825/C 02/2019

NOTES: (continued)

- 6. Publication IPC-7351 may have alternate designs.
- 7. Solder mask tolerances between and around signal pads can vary based on board fabrication site.

EXAMPLE STENCIL DESIGN

D0008A

SOIC - 1.75 mm max height

SMALL OUTLINE INTEGRATED CIRCUIT



SOLDER PASTE EXAMPLE
BASED ON .005 INCH [0.125 MM] THICK STENCIL
SCALE:8X

4214825/C 02/2019

NOTES: (continued)

8. Laser cutting apertures with trapezoidal walls and rounded corners may offer better paste release. IPC-7525 may have alternate design recommendations.
9. Board assembly site may have different recommendations for stencil design.

IMPORTANT NOTICE AND DISCLAIMER

TI PROVIDES TECHNICAL AND RELIABILITY DATA (INCLUDING DATA SHEETS), DESIGN RESOURCES (INCLUDING REFERENCE DESIGNS), APPLICATION OR OTHER DESIGN ADVICE, WEB TOOLS, SAFETY INFORMATION, AND OTHER RESOURCES "AS IS" AND WITH ALL FAULTS, AND DISCLAIMS ALL WARRANTIES, EXPRESS AND IMPLIED, INCLUDING WITHOUT LIMITATION ANY IMPLIED WARRANTIES OF MERCHANTABILITY, FITNESS FOR A PARTICULAR PURPOSE OR NON-INFRINGEMENT OF THIRD PARTY INTELLECTUAL PROPERTY RIGHTS.

These resources are intended for skilled developers designing with TI products. You are solely responsible for (1) selecting the appropriate TI products for your application, (2) designing, validating and testing your application, and (3) ensuring your application meets applicable standards, and any other safety, security, regulatory or other requirements.

These resources are subject to change without notice. TI grants you permission to use these resources only for development of an application that uses the TI products described in the resource. Other reproduction and display of these resources is prohibited. No license is granted to any other TI intellectual property right or to any third party intellectual property right. TI disclaims responsibility for, and you will fully indemnify TI and its representatives against, any claims, damages, costs, losses, and liabilities arising out of your use of these resources.

TI's products are provided subject to [TI's Terms of Sale](#) or other applicable terms available either on [ti.com](https://www.ti.com) or provided in conjunction with such TI products. TI's provision of these resources does not expand or otherwise alter TI's applicable warranties or warranty disclaimers for TI products.

TI objects to and rejects any additional or different terms you may have proposed.

Mailing Address: Texas Instruments, Post Office Box 655303, Dallas, Texas 75265
Copyright © 2025, Texas Instruments Incorporated