

# SN74LV8T596-Q1 Automotive 8-bit Serial-Load Shift Register with Open-Drain Output and Logic-Level Shifter

## 1 Features

- AEC-Q100 qualified for automotive applications:
  - Device temperature grade 1: -40°C to +125°C
  - Device HBM ESD classification level 2
  - Device CDM ESD classification level C4B
- Available in [wetable flank](#) QFN package
- Wide operating range of 1.65V to 5.5V
- 5.5V tolerant input pins
- *LVxT enhanced inputs* combined with *open-drain outputs* provide maximum voltage translation flexibility:
  - Over 6.67Mbps operation, ( $R_{PU} = 1k\Omega$ ,  $C_L = 30pF$ )
  - Up translation from 1.2V to 5V with 1.8V supply
  - Down translation from 5V to 0.8V or even less with any valid supply
- Supports standard function pinout
- Latch-up performance exceeds 250mA per JESD 17

## 2 Applications

- [Digital signage](#)
- [Controlling an indicator LED](#)
- [Increase the number of outputs on a microcontroller](#)

## 3 Description

The SN74LV8T596-Q1 device contains an 8-bit, serial-in, parallel-out shift register that feeds an 8-bit D-type storage register. All inputs include Schmitt-triggers, eliminating any erroneous data outputs due to slow-edged or noisy input signals. The storage register has parallel open-drain outputs. Separate clocks are provided for both the shift and storage register. The shift register has a direct overriding clear ( $\overline{SRCLR}$ ) input, serial (SER) input, and a serial output ( $Q_H$ ) for cascading. When the output-enable ( $\overline{OE}$ ) input is high, the outputs are in a high impedance state. The operation of the  $\overline{OE}$  input does not impact the internal register data.

The input is designed with a reduced threshold circuit to support up translation when the supply voltage is larger than the input voltage. Additionally, the 5V tolerant input pins enable down translation when the input voltage is larger than the supply voltage. The output level is always referenced to the supply voltage ( $V_{CC}$ ) and supports 1.8V, 2.5V, 3.3V, and 5V CMOS levels.

### Package Information

PART NUMBER	PACKAGE <sup>(1)</sup>	PACKAGE SIZE <sup>(2)</sup>	BODY SIZE (NOM) <sup>(3)</sup>
SN74LV8T596-Q1	PW (TSSOP, 16)	5mm × 6.4mm	5mm × 4.4mm
	BQB (WQFN, 16)	3.5mm × 2.5mm	3.5mm × 2.5mm

(1) For more information, see [Section 11](#).

(2) The package size (length × width) is a nominal value and includes pins, where applicable.

(3) The body size (length × width) is a nominal value and does not include pins.



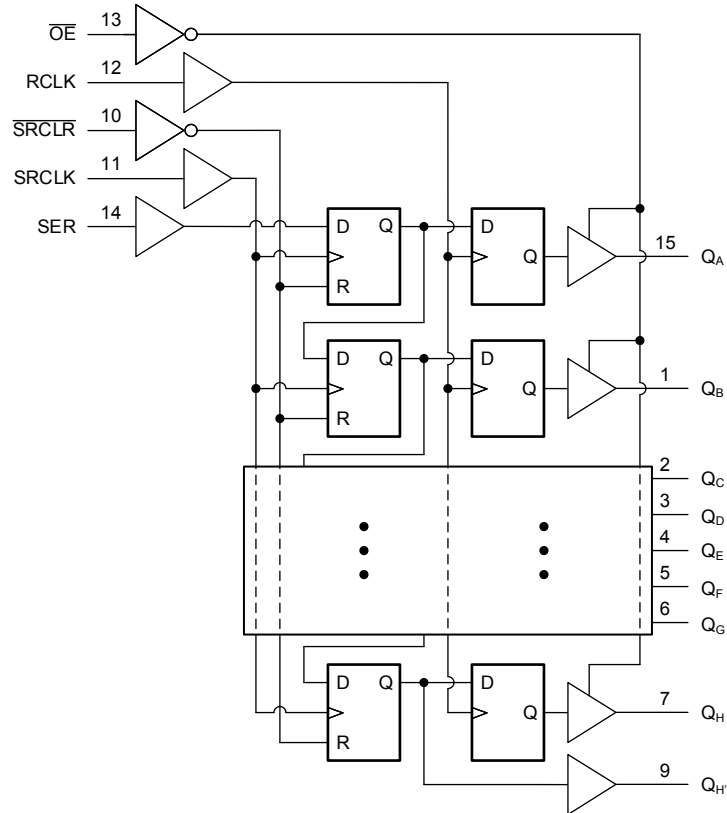

**Simplified Logic Diagram (Positive Logic)**

## Table of Contents

<b>1 Features</b> .....	1	7.3 Feature Description.....	13
<b>2 Applications</b> .....	1	7.4 Device Functional Modes.....	16
<b>3 Description</b> .....	1	<b>8 Application and Implementation</b> .....	17
<b>4 Pin Configuration and Functions</b> .....	4	8.1 Application Information.....	17
<b>5 Specifications</b> .....	5	8.2 Typical Application.....	18
5.1 Absolute Maximum Ratings.....	5	8.3 Power Supply Recommendations.....	20
5.2 ESD Ratings.....	5	8.4 Layout.....	20
5.3 Recommended Operating Conditions.....	5	<b>9 Device and Documentation Support</b> .....	22
5.4 Thermal Information.....	6	9.1 Documentation Support.....	22
5.5 Electrical Characteristics.....	6	9.2 Receiving Notification of Documentation Updates....	22
5.6 Timing Characteristics.....	6	9.3 Support Resources.....	22
5.7 Switching Characteristics.....	7	9.4 Trademarks.....	22
5.8 Noise Characteristics.....	9	9.5 Electrostatic Discharge Caution.....	22
5.9 Typical Characteristics.....	10	9.6 Glossary.....	22
<b>6 Parameter Measurement Information</b> .....	12	<b>10 Revision History</b> .....	22
<b>7 Detailed Description</b> .....	13	<b>11 Mechanical, Packaging, and Orderable Information</b> .....	22
7.1 Overview.....	13		
7.2 Functional Block Diagram.....	13		

## 4 Pin Configuration and Functions

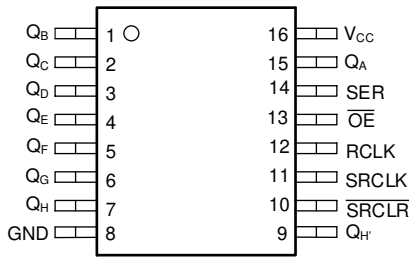

Figure 4-1. PW Package, 16-Pin TSSOP (Top View)

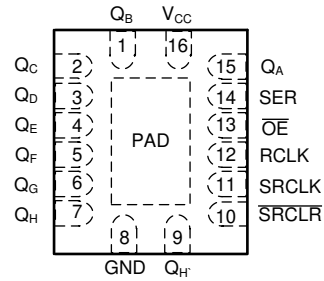

Figure 4-2. BQB Package, 16-Pin WQFN (Transparent Top View)

Table 4-1. Pin Functions

PIN		TYPE <sup>(1)</sup>	DESCRIPTION
NAME	NO.		
Q <sub>B</sub>	1	O	Q <sub>B</sub> output (open-drain)
Q <sub>C</sub>	2	O	Q <sub>C</sub> output (open-drain)
Q <sub>D</sub>	3	O	Q <sub>D</sub> output (open-drain)
Q <sub>E</sub>	4	O	Q <sub>E</sub> output (open-drain)
Q <sub>F</sub>	5	O	Q <sub>F</sub> output (open-drain)
Q <sub>G</sub>	6	O	Q <sub>G</sub> output (open-drain)
Q <sub>H</sub>	7	O	Q <sub>H</sub> output (open-drain)
GND	8	G	Ground
Q <sub>H'</sub>	9	O	Serial output, can be used for cascading (push-pull)
SRCLR	10	I	Shift register clear, active low
SRCLK	11	I	Shift register clock, rising edge triggered
RCLK	12	I	Output register clock, rising edge triggered
OE	13	I	Output enable, active low
SER	14	I	Serial input
Q <sub>A</sub>	15	O	Q <sub>A</sub> output (open-drain)
V <sub>CC</sub>	16	P	Positive supply
Thermal Pad <sup>(2)</sup>		—	The thermal pad can be connect to GND or left floating. Do not connect to any other signal or supply.

(1) I = Input, O = Output, I/O = Input or Output, G = Ground, P = Power

(2) WBQB package only

## 5 Specifications

### 5.1 Absolute Maximum Ratings

over operating free-air temperature range (unless otherwise noted)<sup>(1)</sup>

			MIN	MAX	UNIT
V <sub>CC</sub>	Supply voltage range		-0.5	7	V
V <sub>I</sub>	Input voltage range <sup>(2)</sup>		-0.5	7	V
V <sub>O</sub>	Voltage range applied to any output in the high-impedance or power-off state <sup>(2)</sup>		-0.5	7	V
V <sub>O</sub>	Output voltage range <sup>(2)</sup>		-0.5	V <sub>CC</sub> + 0.5	V
I <sub>IK</sub>	Input clamp current	V <sub>I</sub> < -0.5V		-20	mA
I <sub>OK</sub>	Output clamp current	V <sub>O</sub> < -0.5V or V <sub>O</sub> > V <sub>CC</sub> + 0.5V		±20	mA
I <sub>O</sub>	Continuous output current	V <sub>O</sub> = 0 to V <sub>CC</sub>		±25	mA
	Continuous output current through V <sub>CC</sub> or GND			±75	mA
T <sub>J</sub>	Junction temperature			150	°C
T <sub>stg</sub>	Storage temperature		-65	150	°C

- (1) Operation outside the *Absolute Maximum Ratings* may cause permanent device damage. Absolute maximum ratings do not imply functional operation of the device at these or any other conditions beyond those listed under *Recommended Operating Conditions*. If briefly operating outside the *Recommended Operating Conditions* but within the *Absolute Maximum Ratings*, the device may not sustain damage, but it may not be fully functional. Operating the device in this manner may affect device reliability, functionality, performance, and shorten the device lifetime.
- (2) The input and output voltage ratings may be exceeded if the input and output current ratings are observed.

### 5.2 ESD Ratings

			VALUE	UNIT
V <sub>(ESD)</sub>	Electrostatic discharge	Human body model (HBM), per AEC Q100-002 HBM ESD Classification Level 2 <sup>(1)</sup>	±2000	V
		Charged device model (CDM), per AEC Q100-011 CDM ESD Classification Level C4B	±1000	

- (1) AEC Q100-002 indicate that HBM stressing shall be in accordance with the ANSI/ESDA/JEDEC JS-001 specification.

### 5.3 Recommended Operating Conditions

over operating free-air temperature range (unless otherwise noted)

Specification	Description	Condition	MIN	MAX	UNIT
V <sub>CC</sub>	Supply voltage		1.65	5.5	V
V <sub>I</sub>	Input voltage		0	5.5	V
V <sub>O</sub>	Output voltage		0	V <sub>CC</sub>	V
V <sub>IH</sub>	High-level input voltage	V <sub>CC</sub> = 1.65V to 2V	1.1		V
		V <sub>CC</sub> = 2.25V to 2.75V	1.28		
		V <sub>CC</sub> = 3V to 3.6V	1.45		
		V <sub>CC</sub> = 4.5V to 5.5V	2		
V <sub>IL</sub>	Low-Level input voltage	V <sub>CC</sub> = 1.65V to 2V		0.51	V
		V <sub>CC</sub> = 2.25V to 2.75V		0.65	
		V <sub>CC</sub> = 3V to 3.6V		0.75	
		V <sub>CC</sub> = 4.5V to 5.5V		0.8	
I <sub>O</sub>	Output current	V <sub>CC</sub> = 1.65V to 2V		±8	mA
		V <sub>CC</sub> = 2.25V to 2.75V		±15	
		V <sub>CC</sub> = 3.3V to 5.0V		±25	
Δt/Δv	Input transition rise or fall rate	V <sub>CC</sub> = 1.65V to 5.0V		20	ns/V
Δt/ΔV <sub>CC</sub>	Safe supply ramp rate for POR	V <sub>CC</sub> = 1.65V to 5.5V	6		μs/V

### 5.3 Recommended Operating Conditions (continued)

over operating free-air temperature range (unless otherwise noted)

Specification	Description	Condition	MIN	MAX	UNIT
T <sub>A</sub>	Operating free-air temperature		-40	125	°C

### 5.4 Thermal Information

THERMAL METRIC <sup>(1)</sup>		WBQB (WQFN)	PW (TSSOP)	UNIT
		16 PINS	16 PINS	
R <sub>θJA</sub>	Junction-to-ambient thermal resistance	105.6	135.9	°C/W
R <sub>θJC(top)</sub>	Junction-to-case (top) thermal resistance	96.6	70.3	°C/W
R <sub>θJB</sub>	Junction-to-board thermal resistance	75.4	81.3	°C/W
Ψ <sub>JT</sub>	Junction-to-top characterization parameter	19.1	22.5	°C/W
Ψ <sub>JB</sub>	Junction-to-board characterization parameter	75.4	80.8	°C/W
R <sub>θJC(bot)</sub>	Junction-to-case (bottom) thermal resistance	56.1	N/A	°C/W

(1) For more information about traditional and new thermal metrics, see the [Semiconductor and IC Package Thermal Metrics](#) application report.

### 5.5 Electrical Characteristics

over operating free-air temperature range (unless otherwise noted)

PARAMETER	TEST CONDITIONS	V <sub>CC</sub>	T <sub>A</sub> = 25°C			-40°C to 125°C			UNIT
			MIN	TYP	MAX	MIN	TYP	MAX	
V <sub>OL</sub>	I <sub>OL</sub> = 50μA	1.65V to 5.5V	0.1			0.1			V
	I <sub>OL</sub> = 2mA	1.65V to 2V	0.1 <sup>(1)</sup>	0.2		0.25			
	I <sub>OL</sub> = 3mA	2.25V to 2.75V	0.1 <sup>(1)</sup>	0.15		0.2			
	I <sub>OL</sub> = 5.5mA	3V to 3.6V	0.2 <sup>(1)</sup>	0.2		0.25			
	I <sub>OL</sub> = 8mA	4.5V to 5.5V	0.3 <sup>(1)</sup>	0.3		0.35			
I <sub>I</sub>	V <sub>I</sub> = 0V or V <sub>CC</sub>	0V to 5.5V	±0.1			±1			μA
I <sub>CC</sub>	V <sub>I</sub> = 0V or V <sub>CC</sub> , I <sub>O</sub> = 0; open on loading	1.65V to 5.5V	2			20			μA
ΔI <sub>CC</sub>	One input at 0.3V or 3.4V, other inputs at 0 or V <sub>CC</sub> , I <sub>O</sub> = 0	5.5V	1.35			1.5			mA
	One input at 0.3V or 1.1V, other inputs at 0 or V <sub>CC</sub> , I <sub>O</sub> = 0	1.8V	10			20			μA
C <sub>I</sub>	V <sub>I</sub> = V <sub>CC</sub> or GND	5V	4 10			10			pF
C <sub>O</sub>	V <sub>O</sub> = V <sub>CC</sub> or GND	5V	3						pF
C <sub>PD</sub>	No load, F = 1MHz	5V	129						pF
V <sub>POR</sub>	V <sub>CC</sub> ramp rate of 6μs/V to 100ms/V	1.65V to 5.5V	1.5			1.5			V

(1) Typical value at nearest nominal voltage (1.8V, 2.5V, 3.3V, and 5V)

### 5.6 Timing Characteristics

over recommended operating free-air temperature range (unless otherwise noted)

PARAMETER	DESCRIPTION	CONDITION	V <sub>CC</sub>	T <sub>A</sub> = 25°C		-40°C to 85°C	-40°C to 125°C	UNIT
				MIN	MAX	MIN	MAX	
t <sub>H</sub>	Hold time	SER after SRCLK↑	1.8V	0		0	0	ns
t <sub>SU</sub>	Setup time	SER before SRCLK↑	1.8V	7.9		9.8	9.8	ns
t <sub>SU</sub>	Setup time	SRCLK↑ before RCLK↑	1.8V	8.1		10.1	10.1	ns

## 5.6 Timing Characteristics (continued)

over recommended operating free-air temperature range (unless otherwise noted)

PARAMETER	DESCRIPTION	CONDITION	V <sub>CC</sub>	T <sub>A</sub> = 25°C		-40°C to 85°C		-40°C to 125°C		UNIT
				MIN	MAX	MIN	MAX	MIN	MAX	
t <sub>SU</sub>	Setup time	SRCLR high (inactive) before SRCLK↑	1.8V	2.2		3		3		ns
t <sub>SU</sub>	Setup time	SRCLR low before RCLK↑	1.8V	8.9		11.2		11.2		ns
t <sub>W</sub>	Pulse duration	RCLK or SRCLK high or low	1.8V	5.9		7		7		ns
t <sub>W</sub>	Pulse duration	RCLR or SCRCLR low	1.8V	6.5		8.3		8.3		ns
t <sub>H</sub>	Hold time	SER after SRCLK↑	2.5V	0		0		0		ns
t <sub>SU</sub>	Setup time	SER before SRCLK↑	2.5V	4.6		5.9		5.9		ns
t <sub>SU</sub>	Setup time	SRCLK↑ before RCLK↑	2.5V	3.9		5.3		5.3		ns
t <sub>SU</sub>	Setup time	SRCLR high (inactive) before SRCLK↑	2.5V	1.1		1.7		1.7		ns
t <sub>SU</sub>	Setup time	SRCLR low before RCLK↑	2.5V	5.1		6.6		6.6		ns
t <sub>W</sub>	Pulse duration	RCLK or SRCLK high or low	2.5V	4.3		4.3		4.3		ns
t <sub>W</sub>	Pulse duration	RCLR or SCRCLR low	2.5V	4.3		5.2		5.2		ns
t <sub>H</sub>	Hold time	SER after SRCLK↑	3.3V	0		0		0		ns
t <sub>SU</sub>	Setup time	SER before SRCLK↑	3.3V	3.2		4		4		ns
t <sub>SU</sub>	Setup time	SRCLK↑ before RCLK↑	3.3V	2.5		3.2		3.2		ns
t <sub>SU</sub>	Setup time	SRCLR high (inactive) before SRCLK↑	3.3V	0.7		1		1		ns
t <sub>SU</sub>	Setup time	SRCLR low before RCLK↑	3.3V	3.6		4.5		4.5		ns
t <sub>W</sub>	Pulse duration	RCLK or SRCLK high or low	3.3V	4.3		4.3		4.3		ns
t <sub>W</sub>	Pulse duration	RCLR or SCRCLR low	3.3V	4.3		4.3		4.3		ns
t <sub>H</sub>	Hold time	SER after SRCLK↑	5V	0		0		0		ns
t <sub>SU</sub>	Setup time	SER before SRCLK↑	5V	1.3		1.8		1.8		ns
t <sub>SU</sub>	Setup time	SRCLK↑ before RCLK↑	5V	1.6		2.1		2.1		ns
t <sub>SU</sub>	Setup time	SRCLR high (inactive) before SRCLK↑	5V	0.5		0.7		0.7		ns
t <sub>SU</sub>	Setup time	SRCLR low before RCLK↑	5V	1.6		2.1		2.1		ns
t <sub>W</sub>	Pulse duration	RCLK or SRCLK high or low	5V	4.3		4.3		4.3		ns
t <sub>W</sub>	Pulse duration	RCLR or SCRCLR low	5V	4.3		4.3		4.3		ns

## 5.7 Switching Characteristics

over operating free-air temperature range(unless otherwise noted). See *Parameter Measurement Information*

PARAMETER	FROM (INPUT)	TO (OUTPUT)	LOAD CAPACITANCE	V <sub>CC</sub>	T <sub>A</sub> = 25°C			-40°C to 85°C			-40°C to 125°C			UNIT
					MIN	TYP	MAX	MIN	TYP	MAX	MIN	TYP	MAX	
F <sub>MAX</sub>	-	-	C <sub>L</sub> = 15pF	1.8V	46.3	60		39.4			39.4			MHz
t <sub>PZL</sub>	OE	Q	C <sub>L</sub> = 15pF	1.8V		11.9	27.9	1	31.5	1	31.5			ns
t <sub>PZH</sub>	OE	Q	C <sub>L</sub> = 15pF	1.8V		9.4	21	1	24.4	1	24.4			ns
t <sub>PLZ</sub>	OE	Q	C <sub>L</sub> = 15pF	1.8V		8.3	20.2	1	21.9	1	21.9			ns
t <sub>PHZ</sub>	OE	Q	C <sub>L</sub> = 15pF	1.8V		8.3	22.1	1	24.7	1	24.7			ns
t <sub>PLH</sub>	RCLK	Q <sub>A</sub> -Q <sub>H</sub>	C <sub>L</sub> = 15pF	1.8V		9.4	27	1	28.5	1	29.4			ns
t <sub>PHL</sub>	RCLK	Q <sub>A</sub> -Q <sub>H</sub>	C <sub>L</sub> = 15pF	1.8V		9.4	23.9	1	26.8	1	26.8			ns
t <sub>PLH</sub>	SRCLK	Q <sub>H'</sub>	C <sub>L</sub> = 15pF	1.8V		9.9	20.4	1	23.5	1	23.5			ns
t <sub>PHL</sub>	SRCLK	Q <sub>H'</sub>	C <sub>L</sub> = 15pF	1.8V		9.9	23.9	1	26.9	1	26.9			ns
t <sub>PHL</sub>	SRCLR	Q <sub>H'</sub>	C <sub>L</sub> = 15pF	1.8V		9.9	24.5	1	27.8	1	27.8			ns
F <sub>MAX</sub>	-	-	C <sub>L</sub> = 50pF	1.8V	38.1		48	32.6			32.6			MHz

## 5.7 Switching Characteristics (continued)

over operating free-air temperature range(unless otherwise noted). See *Parameter Measurement Information*

PARAMETER	FROM (INPUT)	TO (OUTPUT)	LOAD CAPACITANCE	V <sub>CC</sub>	T <sub>A</sub> = 25°C			-40°C to 85°C			-40°C to 125°C			UNIT
					MIN	TYP	MAX	MIN	TYP	MAX	MIN	TYP	MAX	
t <sub>PZL</sub>	OE	Q	C <sub>L</sub> = 50pF	1.8V	14.9	51.3		1	56.6		1	56.6	ns	
t <sub>PZH</sub>	OE	Q	C <sub>L</sub> = 50pF	1.8V	12.5	25.8		1	29.8		1	29.8	ns	
t <sub>PLZ</sub>	OE	Q	C <sub>L</sub> = 50pF	1.8V	7.5	28.5		1	29.3		1	29.3	ns	
t <sub>PHZ</sub>	OE	Q	C <sub>L</sub> = 50pF	1.8V	7.7	31		1	33.1		1	33.1	ns	
t <sub>PLH</sub>	RCLK	Q <sub>A</sub> -Q <sub>H</sub>	C <sub>L</sub> = 50pF	1.8V	12.3	52.3		1	53.6		1	54.2	ns	
t <sub>PHL</sub>	RCLK	Q <sub>A</sub> -Q <sub>H</sub>	C <sub>L</sub> = 50pF	1.8V	12.3	28.9		1	32.1		1	32.1	ns	
t <sub>PLH</sub>	SRCLK	Q <sub>H'</sub>	C <sub>L</sub> = 50pF	1.8V	14.1	25.2		1	28.7		1	28.7	ns	
t <sub>PHL</sub>	SRCLK	Q <sub>H'</sub>	C <sub>L</sub> = 50pF	1.8V	14.1	28.8		1	32.1		1	32.1	ns	
t <sub>PHL</sub>	SRCLR	Q <sub>H'</sub>	C <sub>L</sub> = 50pF	1.8V	14.1	29.5		1	33		1	33	ns	
F <sub>MAX</sub>	-	-	C <sub>L</sub> = 15pF	2.5V	66.2	85.8		56.4			56.4		MHz	
t <sub>PZL</sub>	OE	Q	C <sub>L</sub> = 15pF	2.5V	9.1	15.7		1	18.8		1	18.8	ns	
t <sub>PZH</sub>	OE	Q	C <sub>L</sub> = 15pF	2.5V	7.3	12.4		1	15.2		1	15.2	ns	
t <sub>PLZ</sub>	OE	Q	C <sub>L</sub> = 15pF	2.5V	6.4	22.7		1	24.2		1	24.2	ns	
t <sub>PHZ</sub>	OE	Q	C <sub>L</sub> = 15pF	2.5V	6.4	13		1	15.1		1	15.1	ns	
t <sub>PLH</sub>	RCLK	Q <sub>A</sub> -Q <sub>H</sub>	C <sub>L</sub> = 15pF	2.5V	7.3	22.2		1	23.2		1	23.9	ns	
t <sub>PHL</sub>	RCLK	Q <sub>A</sub> -Q <sub>H</sub>	C <sub>L</sub> = 15pF	2.5V	7.3	12.9		1	15.7		1	15.7	ns	
t <sub>PLH</sub>	SRCLK	Q <sub>H'</sub>	C <sub>L</sub> = 15pF	2.5V	7.6	12.1		1	14.6		1	14.6	ns	
t <sub>PHL</sub>	SRCLK	Q <sub>H'</sub>	C <sub>L</sub> = 15pF	2.5V	7.6	13.1		1	15.8		1	15.8	ns	
t <sub>PHL</sub>	SRCLR	Q <sub>H'</sub>	C <sub>L</sub> = 15pF	2.5V	7.6	14.3		1	17.2		1	17.2	ns	
F <sub>MAX</sub>	-	-	C <sub>L</sub> = 50pF	2.5V	58.8	68.6		46.6			46.6		MHz	
t <sub>PZL</sub>	OE	Q	C <sub>L</sub> = 50pF	2.5V	11.5	28.6		1	34		1	34	ns	
t <sub>PZH</sub>	OE	Q	C <sub>L</sub> = 50pF	2.5V	9.6	15.7		1	18.9		1	18.9	ns	
t <sub>PLZ</sub>	OE	Q	C <sub>L</sub> = 50pF	2.5V	5.7	49.9		1	50.7		1	50.7	ns	
t <sub>PHZ</sub>	OE	Q	C <sub>L</sub> = 50pF	2.5V	5.9	19.3		1	21		1	21	ns	
t <sub>PLH</sub>	RCLK	Q <sub>A</sub> -Q <sub>H</sub>	C <sub>L</sub> = 50pF	2.5V	9.5	47.6		1	48.5		1	49.1	ns	
t <sub>PHL</sub>	RCLK	Q <sub>A</sub> -Q <sub>H</sub>	C <sub>L</sub> = 50pF	2.5V	9.5	16.8		1	19.7		1	19.7	ns	
t <sub>PLH</sub>	SRCLK	Q <sub>H'</sub>	C <sub>L</sub> = 50pF	2.5V	10.8	15.1		1	17.9		1	17.9	ns	
t <sub>PHL</sub>	SRCLK	Q <sub>H'</sub>	C <sub>L</sub> = 50pF	2.5V	10.8	16.8		1	19.7		1	19.7	ns	
t <sub>PHL</sub>	SRCLR	Q <sub>H'</sub>	C <sub>L</sub> = 50pF	2.5V	10.8	18		1	21.1		1	21.1	ns	
F <sub>MAX</sub>	-	-	C <sub>L</sub> = 15pF	3.3V	94.5	122.5		80.5			80.5		MHz	
t <sub>PZL</sub>	OE	Q	C <sub>L</sub> = 15pF	3.3V	7	11.5		1	13.9		1	13.9	ns	
t <sub>PZH</sub>	OE	Q	C <sub>L</sub> = 15pF	3.3V	5.6	9.2		1	11.1		1	11.1	ns	
t <sub>PLZ</sub>	OE	Q	C <sub>L</sub> = 15pF	3.3V	4.9	8.2		1	9.2		1	9.2	ns	
t <sub>PHZ</sub>	OE	Q	C <sub>L</sub> = 15pF	3.3V	4.9	9.8		1	11.2		1	11.2	ns	
t <sub>PLH</sub>	RCLK	Q <sub>A</sub> -Q <sub>H</sub>	C <sub>L</sub> = 15pF	3.3V	5.6	20.9		1	21.7		1	22.2	ns	
t <sub>PHL</sub>	RCLK	Q <sub>A</sub> -Q <sub>H</sub>	C <sub>L</sub> = 15pF	3.3V	5.6	9		1	11		1	11	ns	
t <sub>PLH</sub>	SRCLK	Q <sub>H'</sub>	C <sub>L</sub> = 15pF	3.3V	5.9	9.3		1	11		1	11	ns	
t <sub>PHL</sub>	SRCLK	Q <sub>H'</sub>	C <sub>L</sub> = 15pF	3.3V	5.9	9.1		1	11.1		1	11.1	ns	
t <sub>PHL</sub>	SRCLR	Q <sub>H'</sub>	C <sub>L</sub> = 15pF	3.3V	5.9	10.3		1	12.4		1	12.4	ns	
F <sub>MAX</sub>	-	-	C <sub>L</sub> = 50pF	3.3V	84	98		66.5			66.5		MHz	
t <sub>PZL</sub>	OE	Q	C <sub>L</sub> = 50pF	3.3V	8.8	21.1		1	25.2		1	25.2	ns	
t <sub>PZH</sub>	OE	Q	C <sub>L</sub> = 50pF	3.3V	7.4	11.7		1	14		1	14	ns	

## 5.7 Switching Characteristics (continued)

over operating free-air temperature range(unless otherwise noted). See *Parameter Measurement Information*

PARAMETER	FROM (INPUT)	TO (OUTPUT)	LOAD CAPACITANCE	V <sub>CC</sub>	T <sub>A</sub> = 25°C			-40°C to 85°C			-40°C to 125°C			UNIT
					MIN	TYP	MAX	MIN	TYP	MAX	MIN	TYP	MAX	
t <sub>PLZ</sub>	OE	Q	C <sub>L</sub> = 50pF	3.3V	4.4	12.9		1	13.7		1	13.7	ns	
t <sub>PHZ</sub>	OE	Q	C <sub>L</sub> = 50pF	3.3V	4.6	15.2		1	16.2		1	16.2	ns	
t <sub>PLH</sub>	RCLK	Q <sub>A</sub> -Q <sub>H</sub>	C <sub>L</sub> = 50pF	3.3V	7.3	46.3		1	47		1	47.3	ns	
t <sub>PHL</sub>	RCLK	Q <sub>A</sub> -Q <sub>H</sub>	C <sub>L</sub> = 50pF	3.3V	7.3	12.2		1	14.3		1	14.3	ns	
t <sub>PLH</sub>	SRCLK	Q <sub>H'</sub>	C <sub>L</sub> = 50pF	3.3V	8.3	11.4		1	13.5		1	13.5	ns	
t <sub>PHL</sub>	SRCLK	Q <sub>H'</sub>	C <sub>L</sub> = 50pF	3.3V	8.3	12.2		1	14.4		1	14.4	ns	
t <sub>PHL</sub>	SRCLR	Q <sub>H'</sub>	C <sub>L</sub> = 50pF	3.3V	8.3	13.4		1	15.7		1	15.7	ns	
F <sub>MAX</sub>	-	-	C <sub>L</sub> = 15pF	5V	135	175		115			115		MHz	
t <sub>PZL</sub>	OE	Q	C <sub>L</sub> = 15pF	5V	5.4	8.2		1	9.9		1	9.9	ns	
t <sub>PZH</sub>	OE	Q	C <sub>L</sub> = 15pF	5V	4.3	6.3		1	7.6		1	7.6	ns	
t <sub>PLZ</sub>	OE	Q	C <sub>L</sub> = 15pF	5V	3.8	6.1		1	6.8		1	6.8	ns	
t <sub>PHZ</sub>	OE	Q	C <sub>L</sub> = 15pF	5V	3.8	7.5		1	8.4		1	8.4	ns	
t <sub>PLH</sub>	RCLK	Q <sub>A</sub> -Q <sub>H</sub>	C <sub>L</sub> = 15pF	5V	4.3	21.3		1	21.8		1	22.2	ns	
t <sub>PHL</sub>	RCLK	Q <sub>A</sub> -Q <sub>H</sub>	C <sub>L</sub> = 15pF	5V	4.3	6.8		1	8.1		1	8.1	ns	
t <sub>PLH</sub>	SRCLK	Q <sub>H'</sub>	C <sub>L</sub> = 15pF	5V	4.5	8		1	9.1		1	9.1	ns	
t <sub>PHL</sub>	SRCLK	Q <sub>H'</sub>	C <sub>L</sub> = 15pF	5V	4.5	6.9		1	8.3		1	8.3	ns	
t <sub>PHL</sub>	SRCLR	Q <sub>H'</sub>	C <sub>L</sub> = 15pF	5V	4.5	7		1	8.5		1	8.5	ns	
F <sub>MAX</sub>	-	-	C <sub>L</sub> = 50pF	5V	120	140		95			95		MHz	
t <sub>PZL</sub>	OE	Q	C <sub>L</sub> = 50pF	5V	6.8	15.4		1	18.2		1	18.2	ns	
t <sub>PZH</sub>	OE	Q	C <sub>L</sub> = 50pF	5V	5.7	8.3		1	9.9		1	9.9	ns	
t <sub>PLZ</sub>	OE	Q	C <sub>L</sub> = 50pF	5V	3.4	9.1		1	9.8		1	9.8	ns	
t <sub>PHZ</sub>	OE	Q	C <sub>L</sub> = 50pF	5V	3.5	11.2		1	11.9		1	11.9	ns	
t <sub>PLH</sub>	RCLK	Q <sub>A</sub> -Q <sub>H</sub>	C <sub>L</sub> = 50pF	5V	5.6	46.3		1	46.5		1	46.9	ns	
t <sub>PHL</sub>	RCLK	Q <sub>A</sub> -Q <sub>H</sub>	C <sub>L</sub> = 50pF	5V	5.6	9.3		1	10.9		1	10.9	ns	
t <sub>PLH</sub>	SRCLK	Q <sub>H'</sub>	C <sub>L</sub> = 50pF	5V	6.4	9.5		1	10.9		1	10.9	ns	
t <sub>PHL</sub>	SRCLK	Q <sub>H'</sub>	C <sub>L</sub> = 50pF	5V	6.4	9.3		1	10.9		1	10.9	ns	
t <sub>PHL</sub>	SRCLR	Q <sub>H'</sub>	C <sub>L</sub> = 50pF	5V	6.4	9.4		1	11.1		1	11.1	ns	

## 5.8 Noise Characteristics

V<sub>CC</sub> = 5 V, C<sub>L</sub> = 50 pF, T<sub>A</sub> = 25°C

PARAMETER	DESCRIPTION	MIN	TYP	MAX	UNIT
V <sub>OL(P)</sub>	Quiet output, maximum dynamic V <sub>OL</sub>		0.2	0.8	V
V <sub>OL(V)</sub>	Quiet output, minimum dynamic V <sub>OL</sub>	-0.9	-0.2		V
V <sub>OH(V)</sub>	Quiet output, minimum dynamic V <sub>OH</sub>	4.4	4.7		V
V <sub>IH(D)</sub>	High-level dynamic input voltage	2			V
V <sub>IL(D)</sub>	Low-level dynamic input voltage			0.8	V

## 5.9 Typical Characteristics

$T_A = 25^\circ\text{C}$  (unless otherwise noted)

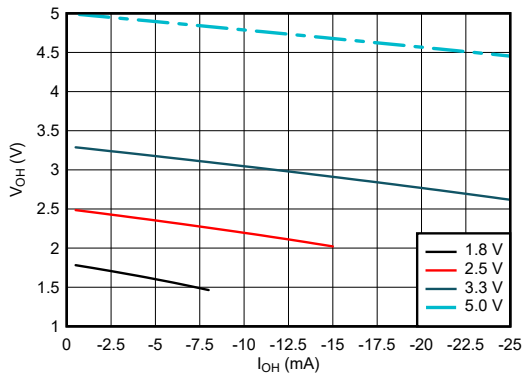

Figure 5-1. Output Voltage vs Current in HIGH State

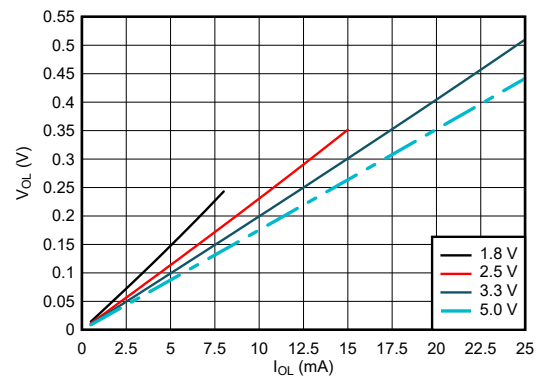

Figure 5-2. Output Voltage vs Current in LOW State

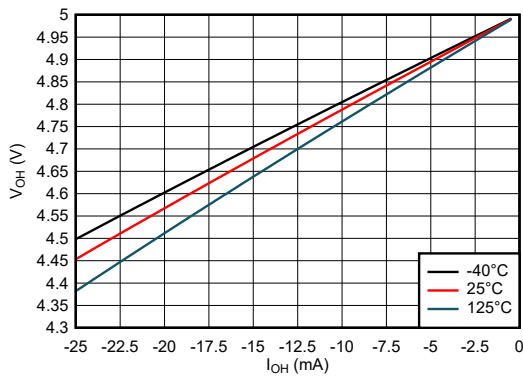

Figure 5-3. Output Voltage vs Current in HIGH State; 5V Supply

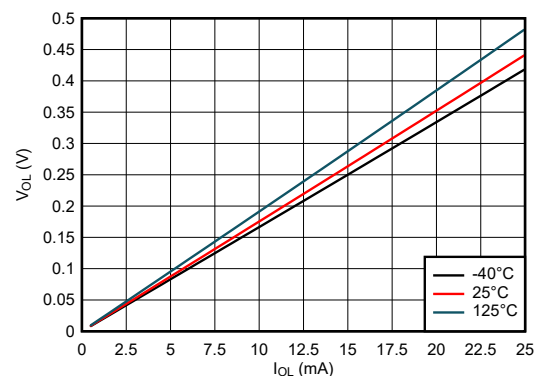

Figure 5-4. Output Voltage vs Current in LOW State; 5V Supply

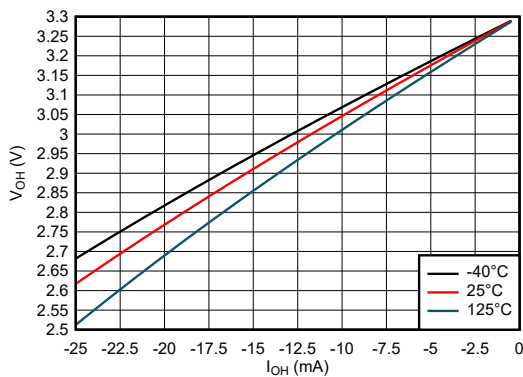

Figure 5-5. Output Voltage vs Current in HIGH State; 3.3V Supply

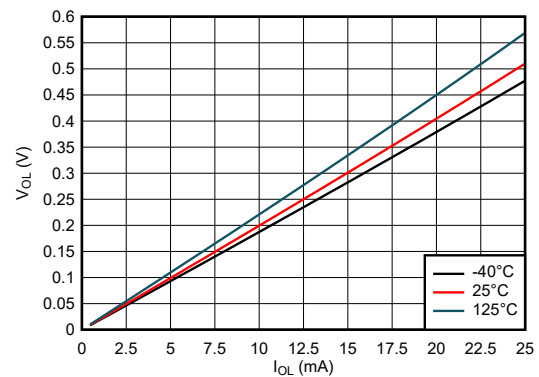
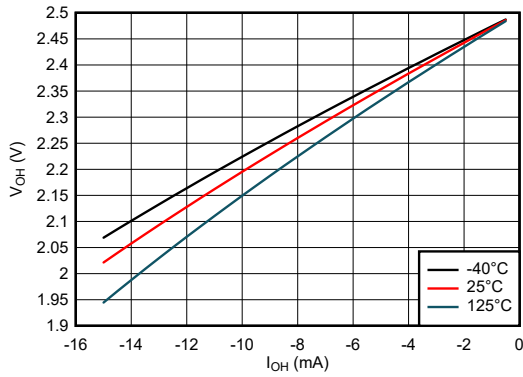

Figure 5-6. Output Voltage vs Current in LOW State; 3.3V Supply

## 5.9 Typical Characteristics (continued)

$T_A = 25^\circ\text{C}$  (unless otherwise noted)



**Figure 5-7. Output Voltage vs Current in HIGH State; 2.5V Supply**

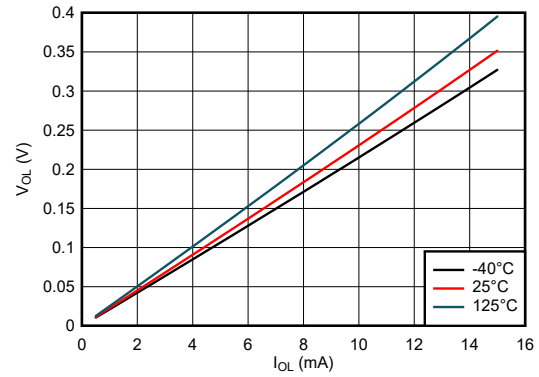

**Figure 5-8. Output Voltage vs Current in LOW State; 2.5V Supply**

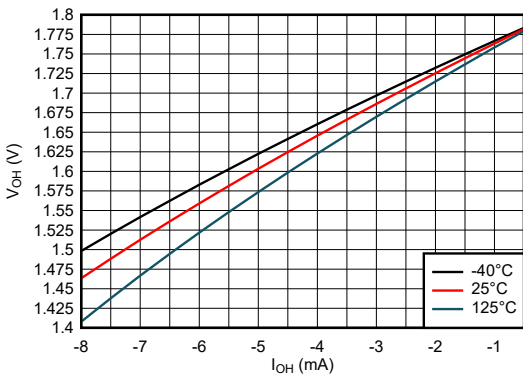

**Figure 5-9. Output Voltage vs Current in HIGH State; 1.8V Supply**

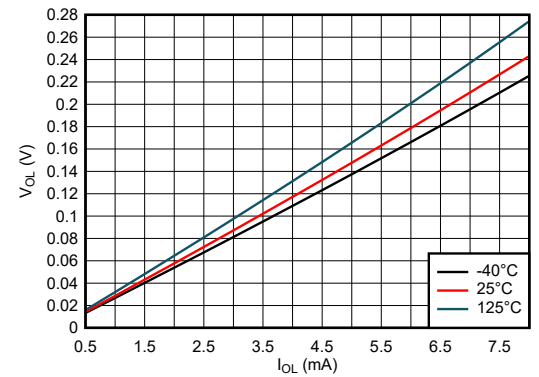

**Figure 5-10. Output Voltage vs Current in LOW State; 1.8V Supply**

## 6 Parameter Measurement Information

Phase relationships between waveforms were chosen arbitrarily for the examples listed in the following table. All input pulses are supplied by generators having the following characteristics:  $PRR \leq 1\text{MHz}$ ,  $Z_O = 50\Omega$ ,  $t_f < 2.5\text{ns}$ .

For clock inputs,  $f_{\text{max}}$  is measured when the input duty cycle is 50%.

The outputs are measured individually with one input transition per measurement.

TEST	S1	R <sub>L</sub>	C <sub>L</sub>	$\Delta V$	V <sub>CC</sub>
$t_{\text{PLZ}}$ , $t_{\text{PZL}}$	CLOSED	1k $\Omega$	15pF, 50pF	0.15V	$\leq 2.5\text{V}$
$t_{\text{PLZ}}$ , $t_{\text{PZL}}$	CLOSED	1k $\Omega$	15pF, 50pF	0.3V	$> 2.5\text{V}$

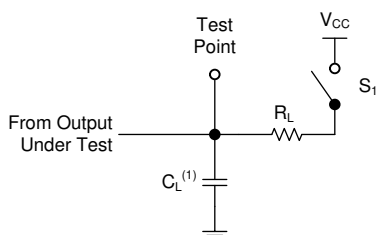

(1) C<sub>L</sub> includes probe and test-fixture capacitance.

**Figure 6-1. Load Circuit for Open-Drain Outputs**

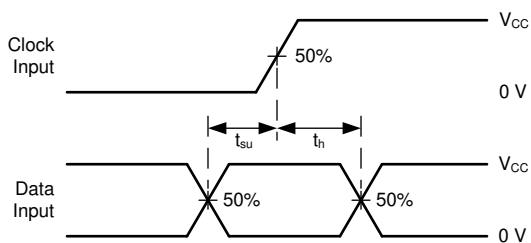

**Figure 6-3. Voltage Waveforms, Setup and Hold Times**

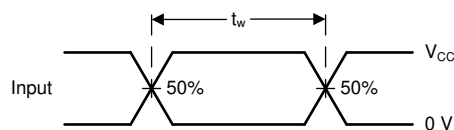

**Figure 6-2. Voltage Waveforms, Pulse Duration**

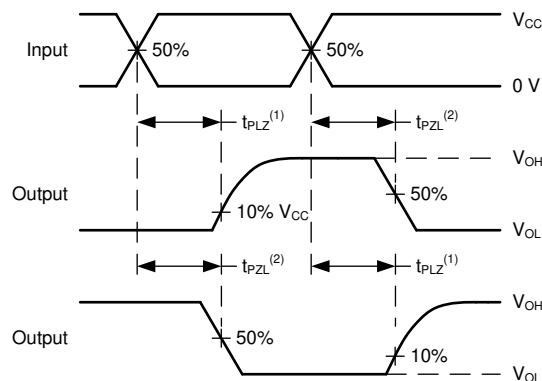

(1)  $t_{\text{PLZ}}$  is the same as  $t_{\text{dis}}$ .

(2)  $t_{\text{PZL}}$  is the same as  $t_{\text{en}}$ .

**Figure 6-4. Voltage Waveforms Propagation Delays**

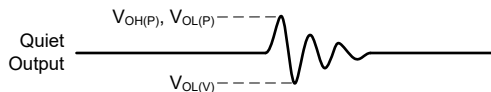

Noise values measured with all other outputs simultaneously switching.

**Figure 6-5. Voltage Waveforms, Noise**

## 7 Detailed Description

### 7.1 Overview

The SN74LV8T596-Q1 is an 8-bit shift register that feeds an 8-bit D-type storage register. Both the shift register clock (SRCLK) and storage register clock (RCLK) are positive-edge triggered. If both clocks are connected together, then the shift register always is one clock pulse ahead of the storage register. All inputs include Schmitt-triggers allowing for slow input transitions and providing more noise margin. Outputs  $Q_A$  through  $Q_H$  are open-drain which require a pull-up resistor to output a High. The serial output  $Q_{H'}$  is push-pull.

### 7.2 Functional Block Diagram

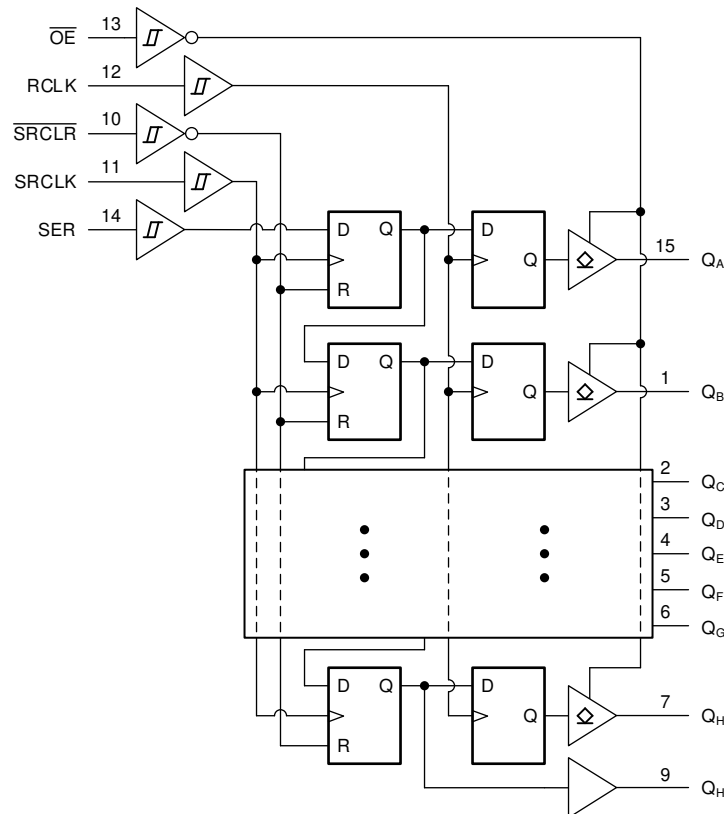

Figure 7-1. Logic Diagram (Positive Logic) for SN74LV8T596-Q1

### 7.3 Feature Description

#### 7.3.1 Open-Drain CMOS Outputs

This device includes open-drain CMOS outputs. Open-drain outputs can only drive the output low. When in the high logical state, open-drain outputs will be in a high-impedance state. The drive capability of this device may create fast edges into light loads, so routing and load conditions should be considered to prevent ringing. Additionally, the outputs of this device can drive larger currents than the device can sustain without being damaged. It is important to limit the output power of the device to avoid damage due to overcurrent. The electrical and thermal limits defined in the *Absolute Maximum Ratings* must be followed at all times.

When placed into the high-impedance state, the output will neither source nor sink current, with the exception of minor leakage current as defined in the *Electrical Characteristics* table. In the high-impedance state, the device does not control the output voltage; the output voltage is dependent on external factors. If no other drivers are connected to the node, then this is known as a floating node and the voltage is unknown. A pull-up resistor can be connected to the output to provide a known voltage at the output while it is in the high-impedance state. The value of the resistor will depend on multiple factors, including parasitic capacitance and power consumption limitations. Typically, a 10kΩ resistor can be used to meet these requirements.

Unused open-drain CMOS outputs should be left disconnected.

### 7.3.2 LVxT Enhanced Input Voltage

The SN74LV8T596-Q1 belongs to TI's LVxT family of logic devices with integrated voltage level translation. This family of devices was designed with reduced input voltage thresholds to support up-translation, and inputs tolerant of signals with up to 5.5V levels to support down-translation. For proper functionality, input signals must remain at or above the specified  $V_{IH(MIN)}$  level for a HIGH input state, and at or below the specified  $V_{IL(MAX)}$  for a LOW input state. Figure 7-2 shows the typical  $V_{IH}$  and  $V_{IL}$  levels for the LVxT family of devices, as well as the voltage levels for standard CMOS devices for comparison.

The inputs are high impedance and are typically modeled as a resistor in parallel with the input capacitance given in the *Electrical Characteristics*. The worst case resistance is calculated with the maximum input voltage, given in the *Absolute Maximum Ratings*, and the maximum input leakage current, given in the *Electrical Characteristics*, using Ohm's law ( $R = V \div I$ ).

Input signals must transition between valid logic states quickly, as defined by the input transition rate in the *Recommended Operating Conditions* table. Failing to meet this specification will result in excessive power consumption and could cause oscillations. For more details, see the [Implications of Slow or Floating CMOS Inputs](#) application report.

Do not leave inputs floating at any time during operation. Unused inputs must be terminated at a valid high or low voltage level. If a system will not be actively driving an input at all times, then a pull-up or pull-down resistor can be added to provide a valid input voltage during these times. The resistor value will depend on multiple factors; however, a 10kΩ resistor is recommended and will typically meet all requirements.

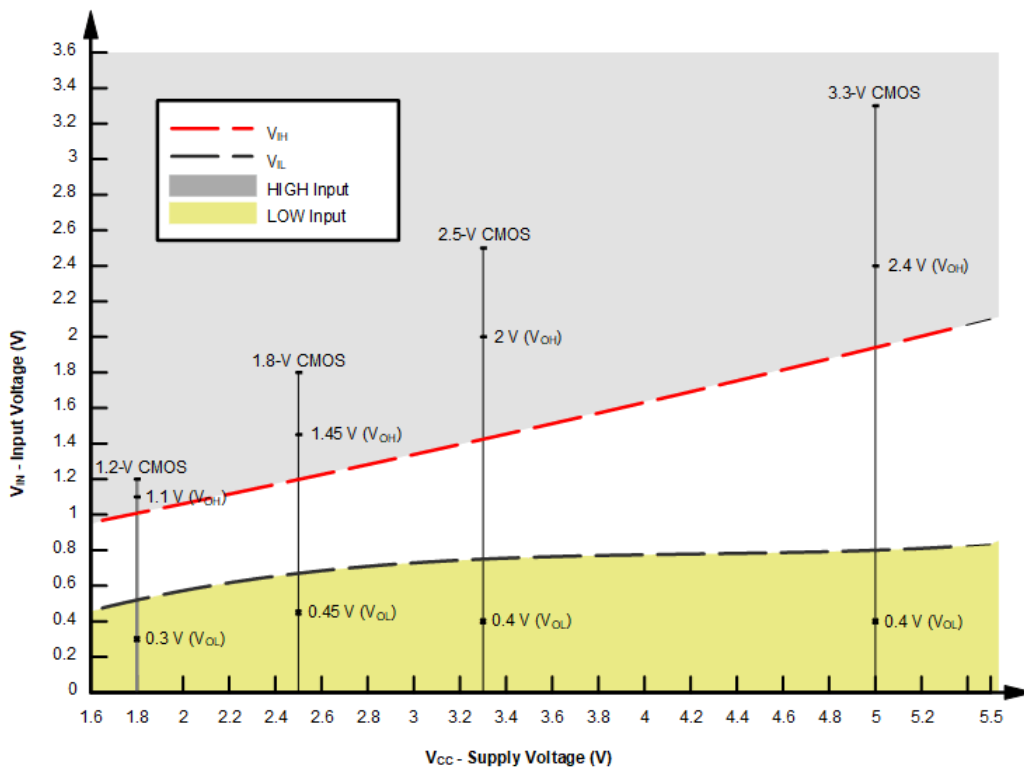
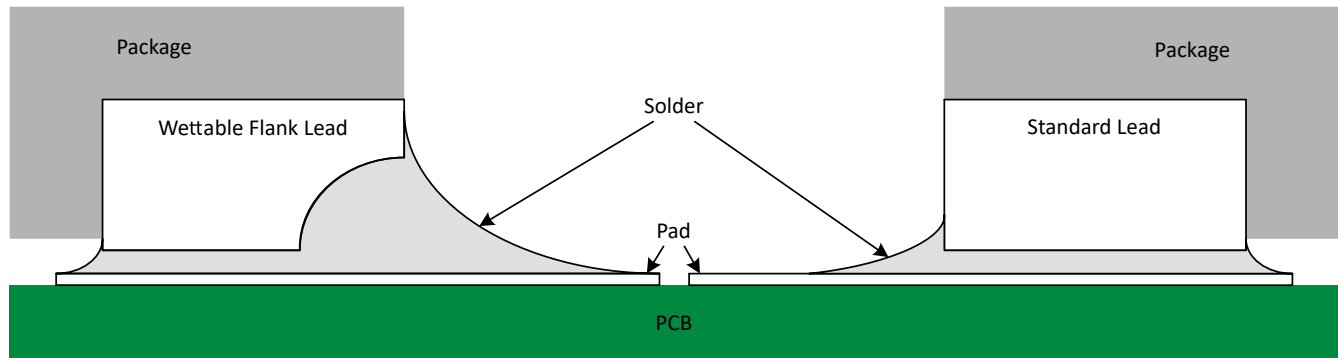

Figure 7-2. LVxT Input Voltage Levels

### 7.3.3 Wettable Flanks

This device includes wettable flanks for at least one package. See the *Features* section on the front page of the data sheet for which packages include this feature.



**Figure 7-3. Simplified Cutaway View of Wettable-Flank QFN Package and Standard QFN Package After Soldering**

Wettable flanks help improve side wetting after soldering, which makes QFN packages easier to inspect with automatic optical inspection (AOI). As shown in [Figure 7-3](#), a wettable flank can be dimpled or step-cut to provide additional surface area for solder adhesion which assists in reliably creating a side fillet. See the mechanical drawing for additional details.

### 7.3.4 Clamp Diode Structure

As [Figure 7-4](#) shows, the outputs to this device have both positive and negative clamping diodes, and the inputs to this device have negative clamping diodes only.

**CAUTION**

Voltages beyond the values specified in the *Absolute Maximum Ratings* table can cause damage to the device. The input and output voltage ratings may be exceeded if the input and output clamp-current ratings are observed.

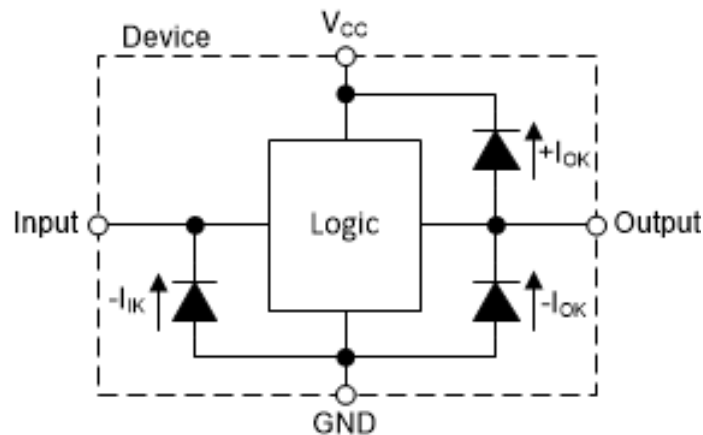

**Figure 7-4. Electrical Placement of Clamping Diodes for Each Input and Output**

## 7.4 Device Functional Modes

Table 7-1 lists the functional modes of the SN74LV8T596-Q1.

**Table 7-1. Function Table**

INPUTS					FUNCTION
SER	SRCLK	SRCLR	RCLK	OE	
X	X	X	X	H	Outputs Q <sub>A</sub> – Q <sub>H</sub> are disabled
X	X	X	X	L	Outputs Q <sub>A</sub> – Q <sub>H</sub> are enabled.
X	X	L	X	X	Shift register is cleared.
L	↑	H	X	X	First stage of the shift register goes low. Other stages store the data of previous stage, respectively.
H	↑	H	X	X	First stage of the shift register goes high. Other stages store the data of previous stage, respectively.
X	X	H	↑	X	Shift-register data is stored in the storage register.
X	↑	H	↑	X	Data in shift register is stored in the storage register, the data is then shifted through.

## 8 Application and Implementation

---

### Note

Information in the following applications sections is not part of the TI component specification, and TI does not warrant its accuracy or completeness. TI's customers are responsible for determining suitability of components for their purposes, as well as validating and testing their design implementation to confirm system functionality.

---

### 8.1 Application Information

In this application, the SN74LV8T596-Q1 is used to control seven-segment displays. Utilizing the serial output and combining a few of the input signals, this implementation reduces the number of I/O pins required to control the displays from sixteen to four. Unlike other I/O expanders, the SN74LV8T596-Q1 does not need a communication interface for control. It can be easily operated with simple GPIO pins.

The OE pin is used to easily disable the outputs when the displays need to be turned off or connected to a PWM signal to control brightness. However, this pin can be tied low and the outputs of the SN74LV8T596-Q1 can be controlled accordingly to turn off all the outputs reducing the I/O needed to three. There is no practical limitation to how many SN74LV8T596-Q1 devices can be cascaded. To add more, the serial output will need to be connected to the following serial input and the clocks will need to be connected accordingly. With separate control for the shift registers and output registers, the desired digit can be displayed while the data for the next digit is loaded into the shift register.

At power-up, the initial state of the shift registers and output registers are unknown. To give them a defined state, the shift register needs to be cleared and then clocked into the output register. An RC circuit can be connected to the  $\overline{\text{SRCLR}}$  pin as shown in the [Figure 8-1](#) to initialize the shift register to all zeros. With the  $\overline{\text{OE}}$  pin pulled up with a resistor, this process can be performed while the outputs are in a high impedance state eliminating any erroneous data causing issues with the displays.

## 8.2 Typical Application

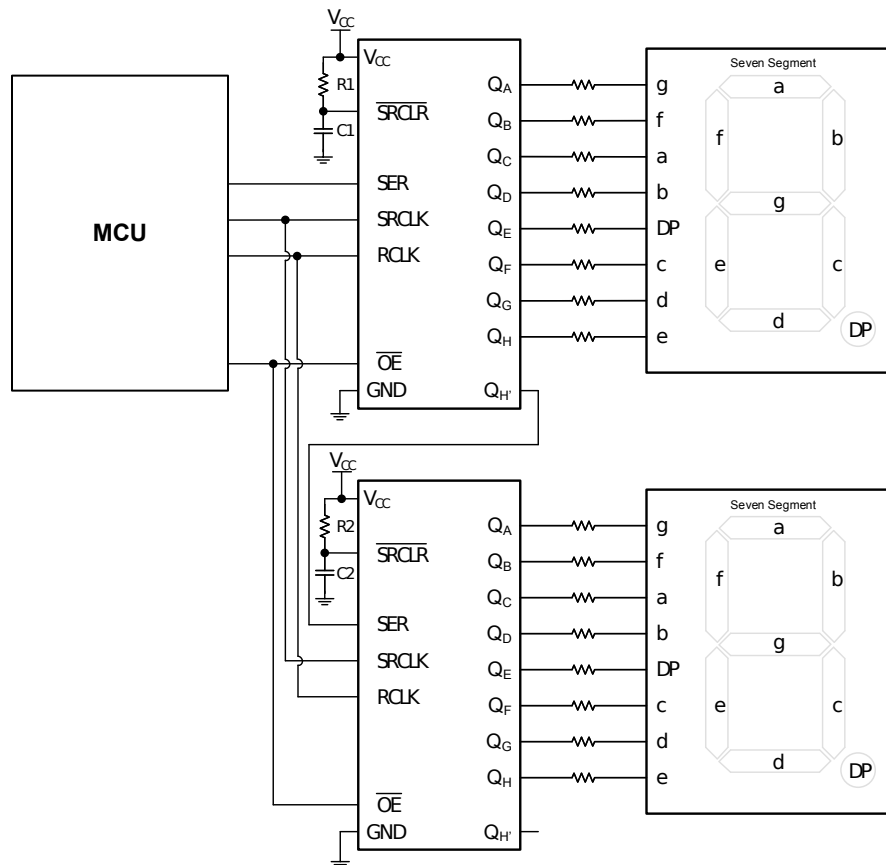

**Figure 8-1. Typical Application Block Diagram**

### 8.2.1 Design Requirements

#### 8.2.1.1 Power Considerations

Ensure the desired supply voltage is within the range specified in the *Recommended Operating Conditions*. The supply voltage sets the device's electrical characteristics as described in the *Electrical Characteristics*.

The positive voltage supply must be capable of sourcing current equal to the maximum static supply current ( $I_{CC}$ ) listed in the *Electrical Characteristics* and any transient current required for switching, is not exceeded.

The ground must be capable of sinking current equal to the total current to be sunk by all outputs of the SN74LV8T596-Q1 plus the maximum supply current ( $I_{CC}$ ) listed in the *Electrical Characteristics*, and any transient current required for switching. The logic device can only sink as much current as can be sunk into its ground connection. Ensure the maximum total current through GND listed in the *Absolute Maximum Ratings* is not exceeded.

The SN74LV8T596-Q1 can drive a load with a total capacitance less than or equal to 50pF while still meeting all of the data sheet specifications. Larger capacitive loads can be applied; however, it is not recommended to exceed 50pF.

The SN74LV8T596-Q1 can drive a load with total resistance described by  $R_L \geq V_O / I_O$ , with the output voltage and current defined in the *Electrical Characteristics* table with  $V_{OL}$ . When outputting in the high state, the output voltage in the equation is defined as the difference between the measured output voltage and the supply voltage at the  $V_{CC}$  pin.

Total power consumption can be calculated using the information provided in [CMOS Power Consumption and Cpd Calculation](#).

Thermal increase can be calculated using the information provided in [Thermal Characteristics of Standard Linear and Logic \(SLL\) Packages and Devices](#).

#### CAUTION

The maximum junction temperature,  $T_{J(max)}$  listed in the *Absolute Maximum Ratings*, is an additional limitation to prevent damage to the device. Do not violate any values listed in the *Absolute Maximum Ratings*. These limits are provided to prevent damage to the device.

#### 8.2.1.2 Input Considerations

Input signals must cross  $V_{IL(max)}$  to be considered a logic LOW, and  $V_{IH(min)}$  to be considered a logic HIGH. Do not exceed the maximum input voltage range found in the *Absolute Maximum Ratings*.

Unused inputs must be terminated to either  $V_{CC}$  or ground. These can be directly terminated if the input is completely unused, or they can be connected with a pull-up or pull-down resistor if the input is to be used sometimes, but not always. A pull-up resistor is used for a default state of HIGH, and a pull-down resistor is used for a default state of LOW. The resistor size is limited by drive current of the controller, leakage current into the SN74LV8T596-Q1, as specified in the *Electrical Characteristics*, and the desired input transition rate. A 10k $\Omega$  resistor value is often used due to these factors.

The SN74LV8T596-Q1 has CMOS inputs and thus requires fast input transitions to operate correctly, as defined in the *Recommended Operating Conditions* table. Slow input transitions can cause oscillations, additional power consumption, and reduction in device reliability.

For additional information regarding the inputs for this device, refer to the *Feature Description*.

#### 8.2.1.3 Output Considerations

The ground voltage is used to produce the output LOW voltage. Sinking current into the output will increase the output voltage as specified by the  $V_{OL}$  specification in the *Electrical Characteristics*.

Open-drain outputs can be connected together directly to produce a wired-AND configuration or for additional output drive strength.

Unused outputs can be left floating. Do not connect outputs directly to  $V_{CC}$  or ground.

Refer to *Feature Description* section for additional information regarding the outputs for this device.

#### 8.2.2 Detailed Design Procedure

1. Add a decoupling capacitor from  $V_{CC}$  to GND. The capacitor needs to be placed physically close to the device and electrically close to both the  $V_{CC}$  and GND pins. An example layout is shown in the *Layout* section.
2. Ensure the capacitive load at the output is  $\leq 50$ pF. This is not a hard limit; by design, however, it will optimize performance. This can be accomplished by providing short, appropriately sized traces from the SN74LV8T596-Q1 to one or more of the receiving devices.
3. Ensure the resistive load at the output is larger than  $(V_{CC} / I_{O(max)})\Omega$ . Doing this will prevent the maximum output current from the *Absolute Maximum Ratings* from being violated. Most CMOS inputs have a resistive load measured in M $\Omega$ ; much larger than the minimum calculated previously.
4. Thermal issues are rarely a concern for logic gates; the power consumption and thermal increase, however, can be calculated using the steps provided in the application report, [CMOS Power Consumption and Cpd Calculation](#).

### 8.2.3 Application Curves

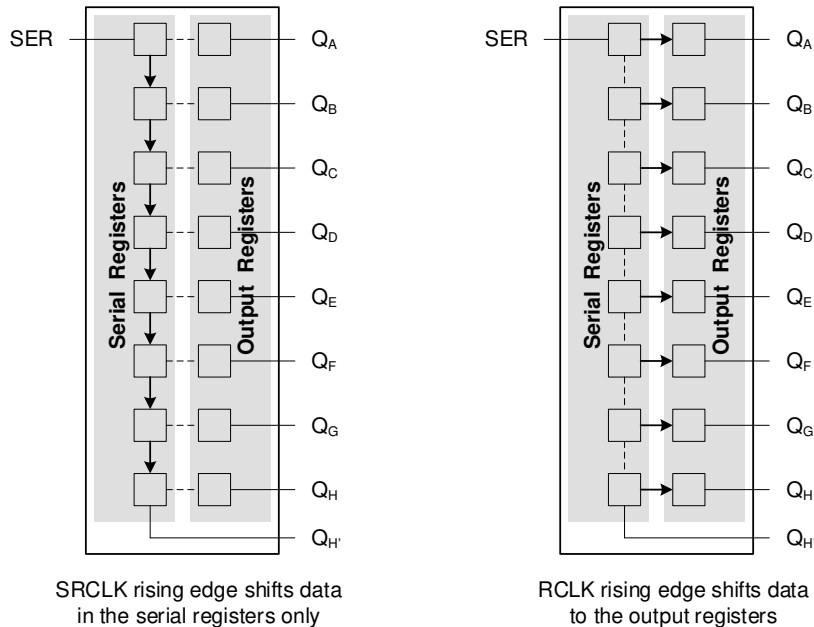

**Figure 8-2. Simplified Functional Diagram Showing Clock Operation**

### 8.3 Power Supply Recommendations

The power supply can be any voltage between the minimum and maximum supply voltage rating located in the *Recommended Operating Conditions*. Each  $V_{CC}$  terminal should have a good bypass capacitor to prevent power disturbance. A 0.1  $\mu\text{F}$  capacitor is recommended for this device. It is acceptable to parallel multiple bypass capacitors to reject different frequencies of noise. The 0.1  $\mu\text{F}$  and 1  $\mu\text{F}$  capacitors are commonly used in parallel. As shown in the following layout example, install the bypass capacitor as close to the power terminal as possible for best results.

### 8.4 Layout

#### 8.4.1 Layout Guidelines

When using multiple-input and multiple-channel logic devices inputs must never be left floating. In many cases, functions or parts of functions of digital logic devices are unused; for example, when only two inputs of a triple-input AND gate are used or only 3 of the 4 buffer gates are used. Such unused input pins must not be left unconnected because the undefined voltages at the outside connections result in undefined operational states. All unused inputs of digital logic devices must be connected to a logic high or logic low voltage, as defined by the input voltage specifications, to prevent them from floating. The logic level that must be applied to any particular unused input depends on the function of the device. Generally, the inputs are tied to GND or  $V_{CC}$ , whichever makes more sense for the logic function or is more convenient.

### 8.4.2 Layout Example

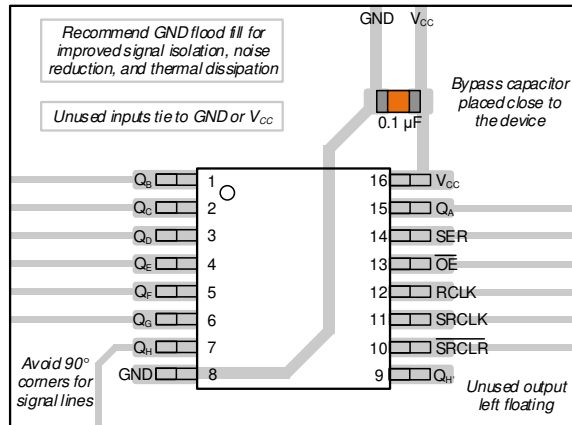

**Figure 8-3. Example Layout for the SN74LV8T596-Q1 in TSSOP**

## 9 Device and Documentation Support

TI offers an extensive line of development tools. Tools and software to evaluate the performance of the device, generate code, and develop solutions are listed below.

### 9.1 Documentation Support

#### 9.1.1 Related Documentation

For related documentation, see the following:

- Texas Instruments, [CMOS Power Consumption and  \$C\_{pd}\$  Calculation application report](#)
- Texas Instruments, [Designing With Logic application report](#)
- Texas Instruments, [Thermal Characteristics of Standard Linear and Logic \(SLL\) Packages and Devices application report](#)

### 9.2 Receiving Notification of Documentation Updates

To receive notification of documentation updates, navigate to the device product folder on [ti.com](http://ti.com). Click on *Notifications* to register and receive a weekly digest of any product information that has changed. For change details, review the revision history included in any revised document.

### 9.3 Support Resources

TI E2E™ [support forums](#) are an engineer's go-to source for fast, verified answers and design help — straight from the experts. Search existing answers or ask your own question to get the quick design help you need.

Linked content is provided "AS IS" by the respective contributors. They do not constitute TI specifications and do not necessarily reflect TI's views; see TI's [Terms of Use](#).

### 9.4 Trademarks

TI E2E™ is a trademark of Texas Instruments.

All trademarks are the property of their respective owners.

### 9.5 Electrostatic Discharge Caution



This integrated circuit can be damaged by ESD. Texas Instruments recommends that all integrated circuits be handled with appropriate precautions. Failure to observe proper handling and installation procedures can cause damage.

ESD damage can range from subtle performance degradation to complete device failure. Precision integrated circuits may be more susceptible to damage because very small parametric changes could cause the device not to meet its published specifications.

### 9.6 Glossary

[TI Glossary](#) This glossary lists and explains terms, acronyms, and definitions.

## 10 Revision History

DATE	REVISION	NOTES
March 2024	*	Initial Release

## 11 Mechanical, Packaging, and Orderable Information

The following pages include mechanical, packaging, and orderable information. This information is the most current data available for the designated devices. This data is subject to change without notice and revision of this document. For browser-based versions of this data sheet, refer to the left-hand navigation.

## PACKAGING INFORMATION

Orderable part number	Status (1)	Material type (2)	Package   Pins	Package qty   Carrier	RoHS (3)	Lead finish/ Ball material (4)	MSL rating/ Peak reflow (5)	Op temp (°C)	Part marking (6)
<a href="#">CLV8T596QWBQRQ1</a>	Active	Production	WQFN (BQB)   16	3000   LARGE T&R	Yes	NIPDAU	Level-1-260C-UNLIM	-40 to 125	LT596Q
CLV8T596QWBQRQ1.A	Active	Production	WQFN (BQB)   16	3000   LARGE T&R	Yes	NIPDAU	Level-1-260C-UNLIM	-40 to 125	LT596Q
<a href="#">SN74LV8T596QPWRQ1</a>	Active	Production	TSSOP (PW)   16	3000   LARGE T&R	Yes	NIPDAU	Level-1-260C-UNLIM	-40 to 125	LVT596Q
SN74LV8T596QPWRQ1.A	Active	Production	TSSOP (PW)   16	3000   LARGE T&R	Yes	NIPDAU	Level-1-260C-UNLIM	-40 to 125	LVT596Q

(1) **Status:** For more details on status, see our [product life cycle](#).

(2) **Material type:** When designated, preproduction parts are prototypes/experimental devices, and are not yet approved or released for full production. Testing and final process, including without limitation quality assurance, reliability performance testing, and/or process qualification, may not yet be complete, and this item is subject to further changes or possible discontinuation. If available for ordering, purchases will be subject to an additional waiver at checkout, and are intended for early internal evaluation purposes only. These items are sold without warranties of any kind.

(3) **RoHS values:** Yes, No, RoHS Exempt. See the [TI RoHS Statement](#) for additional information and value definition.

(4) **Lead finish/Ball material:** Parts may have multiple material finish options. Finish options are separated by a vertical ruled line. Lead finish/Ball material values may wrap to two lines if the finish value exceeds the maximum column width.

(5) **MSL rating/Peak reflow:** The moisture sensitivity level ratings and peak solder (reflow) temperatures. In the event that a part has multiple moisture sensitivity ratings, only the lowest level per JEDEC standards is shown. Refer to the shipping label for the actual reflow temperature that will be used to mount the part to the printed circuit board.

(6) **Part marking:** There may be an additional marking, which relates to the logo, the lot trace code information, or the environmental category of the part.

Multiple part markings will be inside parentheses. Only one part marking contained in parentheses and separated by a "~" will appear on a part. If a line is indented then it is a continuation of the previous line and the two combined represent the entire part marking for that device.

**Important Information and Disclaimer:** The information provided on this page represents TI's knowledge and belief as of the date that it is provided. TI bases its knowledge and belief on information provided by third parties, and makes no representation or warranty as to the accuracy of such information. Efforts are underway to better integrate information from third parties. TI has taken and continues to take reasonable steps to provide representative and accurate information but may not have conducted destructive testing or chemical analysis on incoming materials and chemicals. TI and TI suppliers consider certain information to be proprietary, and thus CAS numbers and other limited information may not be available for release.

In no event shall TI's liability arising out of such information exceed the total purchase price of the TI part(s) at issue in this document sold by TI to Customer on an annual basis.

**OTHER QUALIFIED VERSIONS OF SN74LV8T596-Q1 :**

- Catalog : [SN74LV8T596](#)

NOTE: Qualified Version Definitions:

- Catalog - TI's standard catalog product

**TAPE AND REEL INFORMATION**

**QUADRANT ASSIGNMENTS FOR PIN 1 ORIENTATION IN TAPE**

\*All dimensions are nominal

Device	Package Type	Package Drawing	Pins	SPQ	Reel Diameter (mm)	Reel Width W1 (mm)	A0 (mm)	B0 (mm)	K0 (mm)	P1 (mm)	W (mm)	Pin1 Quadrant
CLV8T596QWBQRQ1	WQFN	BQB	16	3000	180.0	12.4	2.8	3.8	1.2	4.0	12.0	Q1
SN74LV8T596QPWRQ1	TSSOP	PW	16	3000	330.0	12.4	6.9	5.6	1.6	8.0	12.0	Q1

**TAPE AND REEL BOX DIMENSIONS**

\*All dimensions are nominal

Device	Package Type	Package Drawing	Pins	SPQ	Length (mm)	Width (mm)	Height (mm)
CLV8T596QWBQRQ1	WQFN	BQB	16	3000	210.0	185.0	35.0
SN74LV8T596QPWRQ1	TSSOP	PW	16	3000	356.0	356.0	35.0



4220204/A 02/2017

NOTES:

1. All linear dimensions are in millimeters. Any dimensions in parenthesis are for reference only. Dimensioning and tolerancing per ASME Y14.5M.
2. This drawing is subject to change without notice.
3. This dimension does not include mold flash, protrusions, or gate burrs. Mold flash, protrusions, or gate burrs shall not exceed 0.15 mm per side.
4. This dimension does not include interlead flash. Interlead flash shall not exceed 0.25 mm per side.
5. Reference JEDEC registration MO-153.

# EXAMPLE BOARD LAYOUT

PW0016A

TSSOP - 1.2 mm max height

SMALL OUTLINE PACKAGE



LAND PATTERN EXAMPLE  
EXPOSED METAL SHOWN  
SCALE: 10X



SOLDER MASK DETAILS

4220204/A 02/2017

NOTES: (continued)

- 6. Publication IPC-7351 may have alternate designs.
- 7. Solder mask tolerances between and around signal pads can vary based on board fabrication site.

# EXAMPLE STENCIL DESIGN

PW0016A

TSSOP - 1.2 mm max height

SMALL OUTLINE PACKAGE



SOLDER PASTE EXAMPLE  
BASED ON 0.125 mm THICK STENCIL  
SCALE: 10X

4220204/A 02/2017

NOTES: (continued)

8. Laser cutting apertures with trapezoidal walls and rounded corners may offer better paste release. IPC-7525 may have alternate design recommendations.
9. Board assembly site may have different recommendations for stencil design.

## GENERIC PACKAGE VIEW

**BQB 16**

**WQFN - 0.8 mm max height**

2.5 x 3.5, 0.5 mm pitch

PLASTIC QUAD FLATPACK - NO LEAD

This image is a representation of the package family, actual package may vary.  
Refer to the product data sheet for package details.

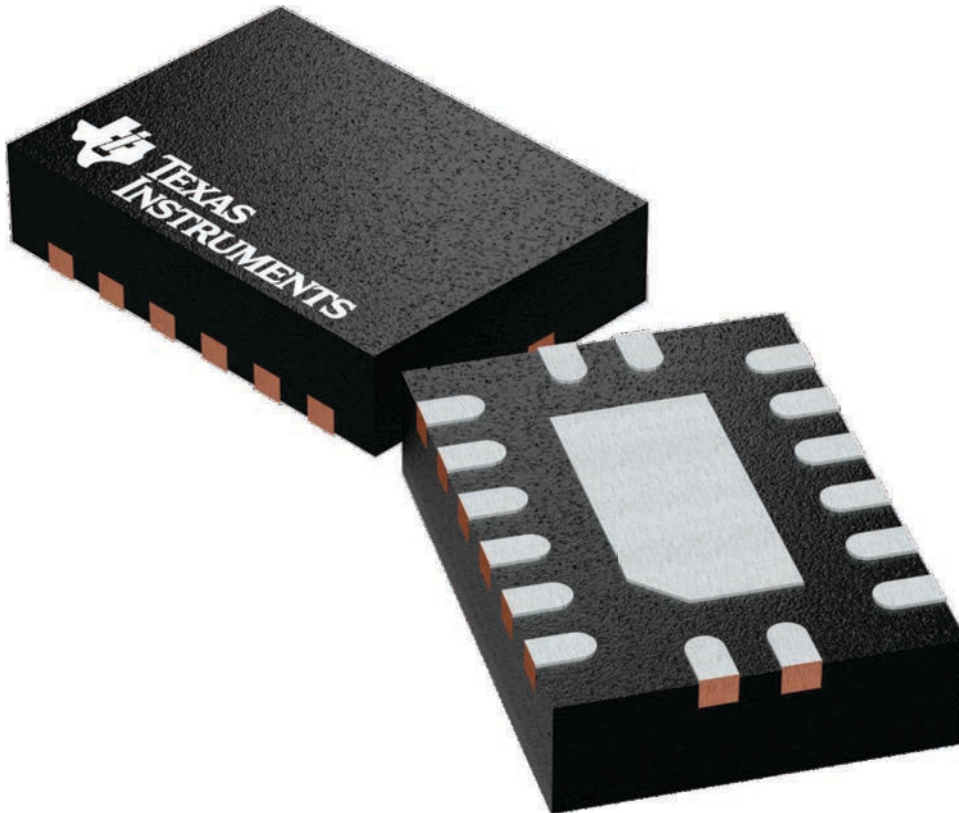

4226161/A

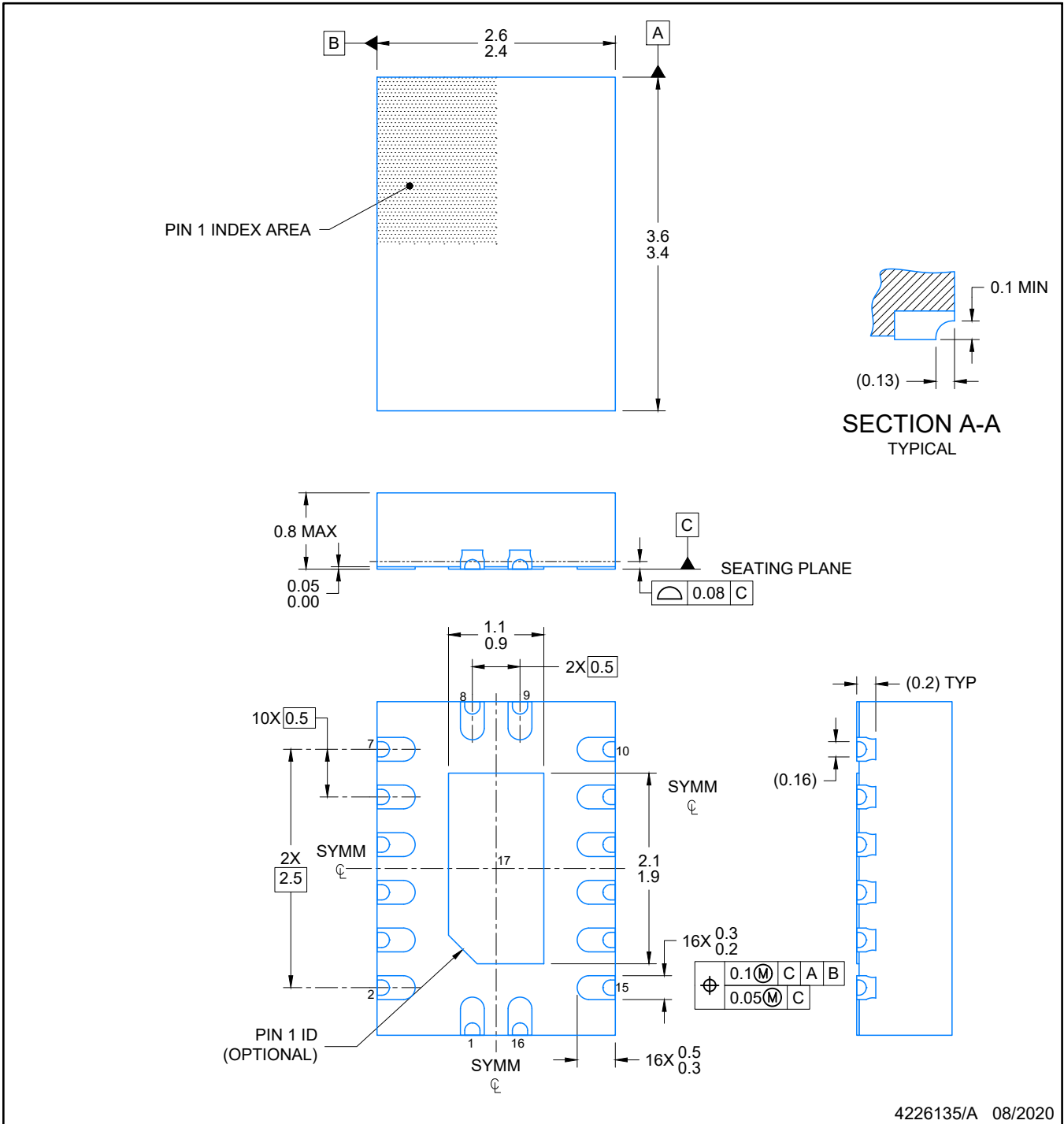

4226135/A 08/2020

**NOTES:**

1. All linear dimensions are in millimeters. Any dimensions in parenthesis are for reference only. Dimensioning and tolerancing per ASME Y14.5M.
2. This drawing is subject to change without notice.
3. The package thermal pad must be soldered to the printed circuit board for optimal thermal and mechanical performance.



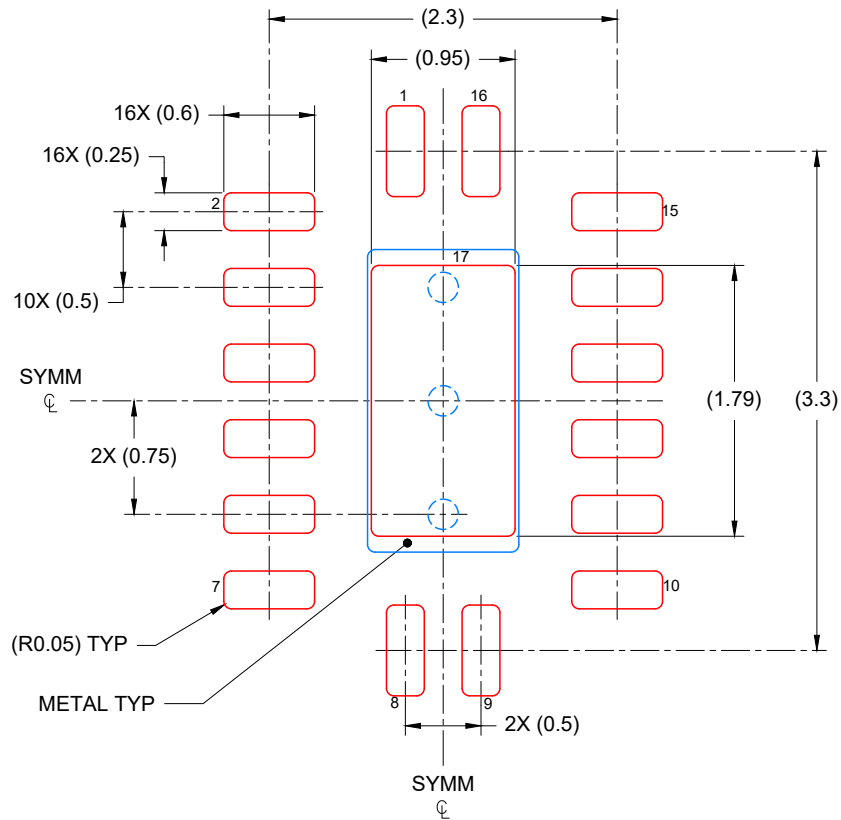

SOLDER PASTE EXAMPLE  
 BASED ON 0.125 mm THICK STENCIL

EXPOSED PAD  
 85% PRINTED COVERAGE BY AREA  
 SCALE: 20X

4226135/A 08/2020

NOTES: (continued)

6. Laser cutting apertures with trapezoidal walls and rounded corners may offer better paste release. IPC-7525 may have alternate design recommendations.

## IMPORTANT NOTICE AND DISCLAIMER

TI PROVIDES TECHNICAL AND RELIABILITY DATA (INCLUDING DATA SHEETS), DESIGN RESOURCES (INCLUDING REFERENCE DESIGNS), APPLICATION OR OTHER DESIGN ADVICE, WEB TOOLS, SAFETY INFORMATION, AND OTHER RESOURCES "AS IS" AND WITH ALL FAULTS, AND DISCLAIMS ALL WARRANTIES, EXPRESS AND IMPLIED, INCLUDING WITHOUT LIMITATION ANY IMPLIED WARRANTIES OF MERCHANTABILITY, FITNESS FOR A PARTICULAR PURPOSE OR NON-INFRINGEMENT OF THIRD PARTY INTELLECTUAL PROPERTY RIGHTS.

These resources are intended for skilled developers designing with TI products. You are solely responsible for (1) selecting the appropriate TI products for your application, (2) designing, validating and testing your application, and (3) ensuring your application meets applicable standards, and any other safety, security, regulatory or other requirements.

These resources are subject to change without notice. TI grants you permission to use these resources only for development of an application that uses the TI products described in the resource. Other reproduction and display of these resources is prohibited. No license is granted to any other TI intellectual property right or to any third party intellectual property right. TI disclaims responsibility for, and you will fully indemnify TI and its representatives against, any claims, damages, costs, losses, and liabilities arising out of your use of these resources.

TI's products are provided subject to [TI's Terms of Sale](#) or other applicable terms available either on [ti.com](https://www.ti.com) or provided in conjunction with such TI products. TI's provision of these resources does not expand or otherwise alter TI's applicable warranties or warranty disclaimers for TI products.

TI objects to and rejects any additional or different terms you may have proposed.

Mailing Address: Texas Instruments, Post Office Box 655303, Dallas, Texas 75265

Copyright © 2025, Texas Instruments Incorporated