

# TMUX13xxA-Q1 Automotive 5V, Bidirectional 8:1, 1-Channel and 4:1, 2-Channel Current Injection Controlled Multiplexers Optimized for High-Impedance Loads

## 1 Features

- AEC-Q100 qualified for automotive applications
  - Device Temperature Grade 1: –40°C to 125°C ambient operating temperature
- [Injection current control](#)
- [Back-powering protection](#)
  - No ESD diode path to  $V_{DD}$
- Wide supply range: 1.62V to 5.5V
- Fast settling times
- Low ON-capacitance
- [Bidirectional signal path](#)
- [Optimized for high-impedance loads](#)
- [Rail-to-rail operation](#)
- [1.8V logic compatible](#)
- [Fail-safe logic](#)
- Break-before-make switching
- [Short-to-battery protection for ON and OFF channels](#)
- [Functional safety-capable](#)
  - [Documentation available to aid functional safety system design](#)
- TMUX1308A-Q1 – pin compatible with:
  - Industry standard 4051, 4851 and 1308 multiplexers
- TMUX1309A-Q1 – pin compatible with:
  - Industry standard 4052, 4852 and 1309 multiplexers

## 2 Applications

- Analog and digital multiplexing and demultiplexing
- Diagnostics and monitoring
- [Zonal architecture](#)
- [Body control modules](#)
- [Battery management systems \(BMS\)](#)
- [HVAC control module](#)
- [Automotive head unit](#)
- [Telematics](#)
- [On-board \(OBC\) and wireless charging](#)

## 3 Description

The TMUX1308A-Q1 and TMUX1309A-Q1 are general purpose complementary metal-oxide semiconductor (CMOS) multiplexers (MUX). The TMUX1308A-Q1 is an 8:1, 1-channel (single-ended) mux, while the TMUX1309A-Q1 is a 4:1, 2-channel (differential) mux. The devices support bidirectional analog and digital signals on the source ( $S_x$ ) and drain ( $D_x$ ) pins ranging from GND to  $V_{DD}$ .

The TMUX13xxA-Q1 devices have an internal injection current control feature, which eliminates the need for external diode and resistor networks typically used to protect the switch and keep the input signals within the supply voltage. The internal injection current control circuitry allows signals on disabled or enabled signal paths to exceed the supply voltage. Disabled channels with voltages above  $V_{DD}$  are prevented from affecting the signal of the enabled signal path. Additionally, the TMUX13xxA-Q1 devices do not have an internal diode path to the supply pin, which eliminates the risk of damaging components connected to the supply pin or providing unintended power to the supply rail. Due to these features RC networks on the input side can be reduced- allowing for a much smaller current limiting resistor which can have a significant impact on the ramp rates.

All logic inputs have [1.8V logic compatible](#) thresholds, allowing for both TTL and CMOS logic compatibility when operating with a valid supply voltage. [Fail-Safe Logic](#) circuitry allows voltages on the control pins to be applied before the supply pin, protecting the device from potential damage.

### Package Information

PART NUMBER	CONFIGURATION <sup>(1)</sup>	PACKAGE <sup>(2)</sup>	BODY SIZE (NOM) <sup>(3)</sup>
TMUX1308A-Q1 TMUX1309A-Q1	Channel 8:1 Channel 4:1	PW (TSSOP, 16)	5mm × 4.4mm
		DYY (SOT-23-THIN, 16)	4.2mm × 2mm
		BQB (WQFN, 16)	3.5mm × 2.5mm

(1) See the [Device Comparison Table](#).

(2) For more information, see [Section 12](#).

(3) The body size (length × width) is a nominal value and does not include pins.



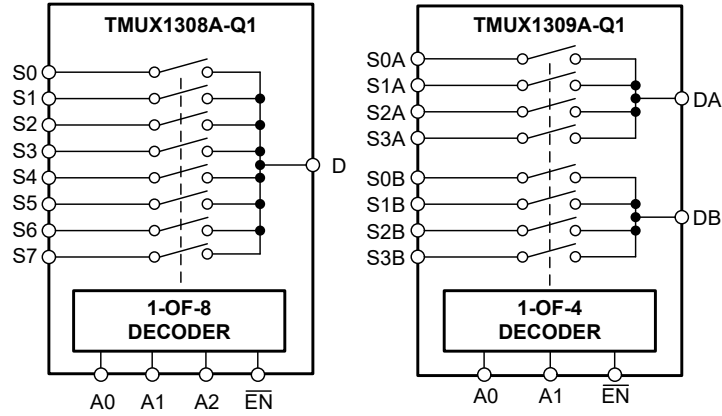

**TMUX1308A-Q1 and TMUX1309A-Q1 Block Diagram**

## Table of Contents

<b>1 Features</b> .....	1	7.9 Crosstalk.....	21
<b>2 Applications</b> .....	1	7.10 Bandwidth.....	21
<b>3 Description</b> .....	1	7.11 Injection Current Control.....	22
<b>4 Device Comparison Table</b> .....	4	<b>8 Detailed Description</b> .....	23
<b>5 Pin Configuration and Functions</b> .....	4	8.1 Overview.....	23
<b>6 Specifications</b> .....	8	8.2 Functional Block Diagram.....	23
6.1 Absolute Maximum Ratings.....	8	8.3 Feature Description.....	23
6.2 ESD Ratings.....	8	8.4 Device Functional Modes.....	28
6.3 Thermal Information: TMUX1308A-Q1.....	9	8.5 Truth Tables.....	29
6.4 Thermal Information: TMUX1309A-Q1.....	9	<b>9 Application and Implementation</b> .....	30
6.5 Recommended Operating Conditions.....	9	9.1 Application Information.....	30
6.6 Electrical Characteristics.....	10	9.2 Typical Application.....	30
6.7 Logic and Dynamic Characteristics.....	11	9.3 Power Supply Recommendations.....	34
6.8 Timing Characteristics.....	12	9.4 Layout.....	35
6.9 Injection Current Coupling.....	13	<b>10 Device and Documentation Support</b> .....	37
6.10 Typical Characteristics.....	14	10.1 Documentation Support.....	37
<b>7 Parameter Measurement Information</b> .....	17	10.2 Receiving Notification of Documentation Updates..	37
7.1 On-Resistance.....	17	10.3 Support Resources.....	37
7.2 Off-Leakage Current.....	17	10.4 Trademarks.....	37
7.3 On-Leakage Current.....	18	10.5 Electrostatic Discharge Caution.....	37
7.4 Transition Time.....	18	10.6 Glossary.....	37
7.5 Break-Before-Make.....	19	<b>11 Revision History</b> .....	37
7.6 $t_{ON(EN)}$ and $t_{OFF(EN)}$ .....	19	<b>12 Mechanical, Packaging, and Orderable Information</b> .....	37
7.7 Charge Injection.....	20		
7.8 Off Isolation.....	20		

## 4 Device Comparison Table

PRODUCT	DESCRIPTION
TMUX1308A-Q1	8:1, 1-channel, single-ended multiplexer
TMUX1309A-Q1	4:1, 2-channel, differential multiplexer

## 5 Pin Configuration and Functions

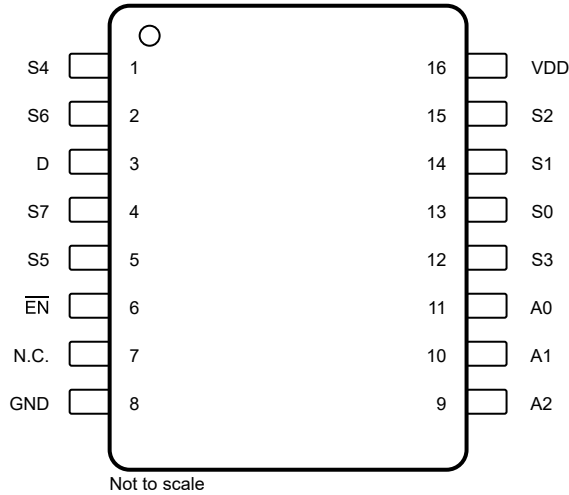

Figure 5-1. TMUX1308A-Q1: PW Package, 16-Pin TSSOP (Top View)

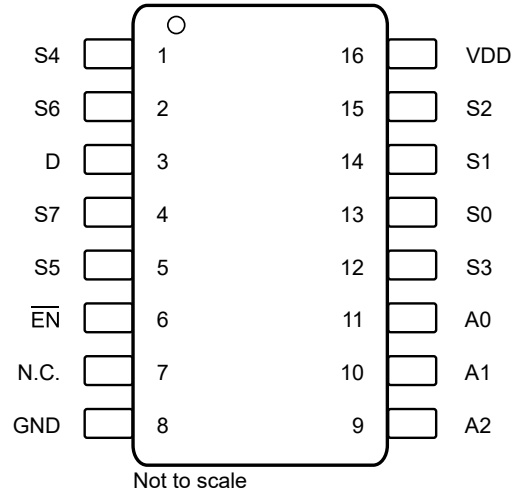

Figure 5-2. TMUX1308A-Q1: DYY Package, 16-Pin SOT-23-THIN (Top View)

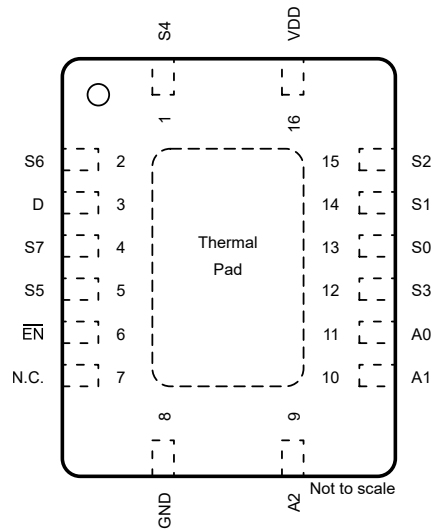
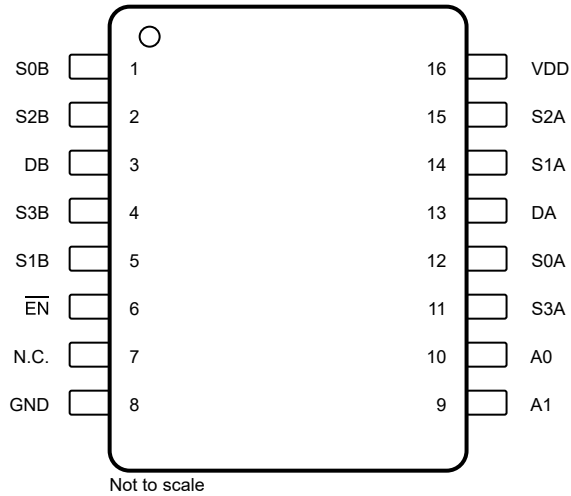

Figure 5-3. TMUX1308A-Q1: BQB Package, 16-Pin WQFN (Top View)

**Table 5-1. Pin Functions TMUX1308A-Q1**

PIN		TYPE <sup>(1)</sup>	DESCRIPTION <sup>(2)</sup>
NAME	NO.		
S4	1	I/O	Source pin 4. Signal path can be an input or output.
S6	2	I/O	Source pin 6. Signal path can be an input or output.
D	3	I/O	Drain pin (common). Signal path can be an input or output.
S7	4	I/O	Source pin 7. Signal path can be an input or output.
S5	5	I/O	Source pin 5. Signal path can be an input or output.
EN	6	I	Active low logic input. When this pin is high, all switches are turned off. When this pin is low, the A[2:0] address inputs determine which switch is turned on as listed in <a href="#">Section 8.5</a> .
N.C.	7	Not Connected	Not internally connected.
GND	8	P	Ground (0V) reference
A2	9	I	Address line 2. Controls the switch configuration as listed in <a href="#">Section 8.5</a> .
A1	10	I	Address line 1. Controls the switch configuration as listed in <a href="#">Section 8.5</a> .
A0	11	I	Address line 0. Controls the switch configuration as listed in <a href="#">Section 8.5</a> .
S3	12	I/O	Source pin 3. Signal path can be an input or output.
S0	13	I/O	Source pin 0. Signal path can be an input or output.
S1	14	I/O	Source pin 1. Signal path can be an input or output.
S2	15	I/O	Source pin 2. Signal path can be an input or output.
VDD	16	P	Positive power supply. This pin is the most positive power-supply potential. For reliable operation, connect a decoupling capacitor ranging from 0.1µF to 10µF between V <sub>DD</sub> and GND.
Thermal pad		—	Exposed thermal pad with conductive die attached. No requirement to solder this pad. If connected, then it should be left floating or tied to GND.

- (1) I = input, O = output, I/O = input and output, P = power.  
(2) For what to do with unused pins, refer to [Section 8.4](#).



**Figure 5-4. TMUX1309A-Q1: PW Package, 16-Pin TSSOP (Top View)**

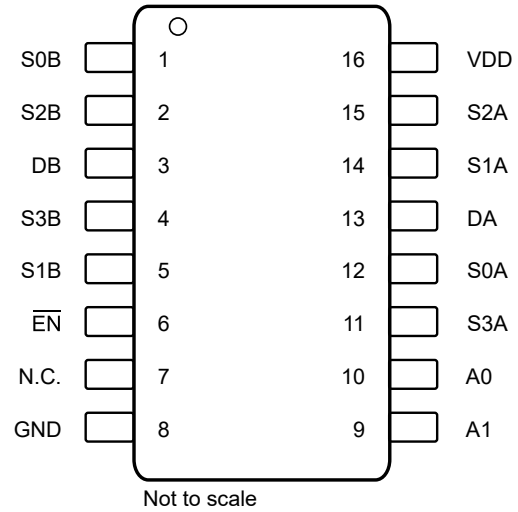

**Figure 5-5. TMUX1309A-Q1: DYY Package, 16-Pin SOT-23-THIN (Top View)**

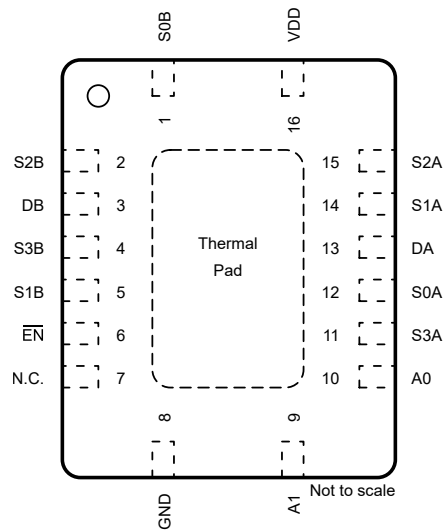

**Figure 5-6. TMUX1309A-Q1: BQB Package, 16-Pin WQFN (Top View)**

**Table 5-2. Pin Functions TMUX1309A-Q1**

PIN		TYPE <sup>(1)</sup>	DESCRIPTION <sup>(2)</sup>
NAME	NO.		
S0B	1	I/O	Source pin 0 of mux B. Can be an input or output.
S2B	2	I/O	Source pin 2 of mux B. Can be an input or output.
DB	3	I/O	Drain pin (Common) of mux B. Can be an input or output.
S3B	4	I/O	Source pin 3 of mux B. Can be an input or output.
S1B	5	I/O	Source pin 1 of mux B. Can be an input or output.
EN	6	I	Active low logic input. When this pin is high, all switches are turned off. When this pin is low, the A[1:0] address inputs determine which switch is turned on.
N.C.	7	Not Connected	Not internally connected.
GND	8	P	Ground (0V) reference
A1	9	I	Address line 1. Controls the switch configuration as listed in <a href="#">Section 8.5</a> .
A0	10	I	Address line 0. Controls the switch configuration as listed in <a href="#">Section 8.5</a> .
S3A	11	I/O	Source pin 3 of mux A. Can be an input or output.
S0A	12	I/O	Source pin 0 of mux A. Can be an input or output.
DA	13	I/O	Drain pin (Common) of mux A. Can be an input or output.
S1A	14	I/O	Source pin 1 of mux A. Can be an input or output.
S2A	15	I/O	Source pin 2 of mux A. Can be an input or output.
VDD	16	P	Positive power supply. This pin is the most positive power-supply potential. For reliable operation, connect a decoupling capacitor ranging from 0.1µF to 10µF between V <sub>DD</sub> and GND.
Thermal pad		—	Exposed thermal pad with conductive die attached. No requirement to solder this pad. If connected, then it should be left floating or tied to GND.

- (1) I = input, O = output, I/O = input and output, P = power.  
(2) For what to do with unused pins, refer to [Section 8.4](#).

## 6 Specifications

### 6.1 Absolute Maximum Ratings

over operating free-air temperature range (unless otherwise noted)<sup>(1)</sup> <sup>(2)</sup> <sup>(3)</sup>

		MIN	MAX	UNIT
$V_{DD}$	Supply voltage	-0.5	6	V
$V_{SEL}$ or $V_{EN}$	Logic control input pin voltage ( $\overline{EN}$ , A0, A1, A2)	-0.5	6	
$V_S$ or $V_D$	Source or drain voltage (Sx, D)	-0.5	$V_{DD}+1.0$	
$I_{SEL}$ or $I_{EN}$	Logic control input pin current ( $\overline{EN}$ , A0, A1, A2)	-30	30	mA
$I_S$ or $I_{D(CONT)}$	Continuous current through switch (Sx, D pins) -40°C to +85°C	-50	50	
$I_S$ or $I_{D(CONT)}$	Continuous current through switch (Sx, D pins) -40°C to +125°C	-25	25	
$I_{GND}$	Continuous current through GND	-100	100	
$P_{tot}$	Total power dissipation <sup>(4)</sup>		500	
$T_{stg}$	Storage temperature	-65	150	°C
$T_J$	Junction temperature		150	

- (1) Operation outside the *Absolute Maximum Ratings* may cause permanent device damage. Absolute maximum ratings do not imply functional operation of the device at these or any other conditions beyond those listed under *Recommended Operating Conditions*. If briefly operating outside the *Recommended Operating Conditions* but within the *Absolute Maximum Ratings*, the device may not sustain damage, but it may not be fully functional. Operating the device in this manner may affect device reliability, functionality, performance, and shorten the device lifetime.
- (2) The algebraic convention, whereby the most negative value is a minimum and the most positive value is a maximum.
- (3) All voltages are with respect to ground, unless otherwise specified.
- (4) For TSSOP package:  $P_{tot}$  derates linearly above  $T_A = 80^\circ\text{C}$  by  $7.2\text{mW}/^\circ\text{C}$ .

### 6.2 ESD Ratings

			VALUE	UNIT
$V_{(ESD)}$	Electrostatic discharge	Human body model (HBM), per AEC Q100-002 <sup>(1)</sup>	±2000	V
		Charged device model (CDM), per AEC Q100-011	±750	

- (1) AEC Q100-002 indicates that HBM stressing shall be in accordance with the ANSI/ESDA/JEDEC JS-001 specification.

### 6.3 Thermal Information: TMUX1308A-Q1

THERMAL METRIC <sup>(1)</sup>		TMUX1308-Q1			UNIT
		PW (TSSOP)	DYY (SOT)	BQB (WQFN)	
		PINS	PINS	PINS	
R <sub>θJA</sub>	Junction-to-ambient thermal resistance	139	167.1	94.8	°C/W
R <sub>θJC(top)</sub>	Junction-to-case (top) thermal resistance	77.2	106.3	92.6	°C/W
R <sub>θJB</sub>	Junction-to-board thermal resistance	84.2	90.0	64.5	°C/W
Ψ <sub>JT</sub>	Junction-to-top characterization parameter	26.5	17.2	13.3	°C/W
Ψ <sub>JB</sub>	Junction-to-board characterization parameter	83.8	90.0	64.4	°C/W
R <sub>θJC(bot)</sub>	Junction-to-case (bottom) thermal resistance	N/A	N/A	42.7	°C/W

(1) For more information about traditional and new thermal metrics, see the [Semiconductor and IC Package Thermal Metrics](#) application note.

### 6.4 Thermal Information: TMUX1309A-Q1

THERMAL METRIC <sup>(1)</sup>		TMUX1309-Q1			UNIT
		PW (TSSOP)	DYY (SOT)	BQB (WQFN)	
		PINS	PINS	PINS	
R <sub>θJA</sub>	Junction-to-ambient thermal resistance	139	172.4	94.8	°C/W
R <sub>θJC(top)</sub>	Junction-to-case (top) thermal resistance	77.2	107.0	92.6	°C/W
R <sub>θJB</sub>	Junction-to-board thermal resistance	84.2	96.1	64.5	°C/W
Ψ <sub>JT</sub>	Junction-to-top characterization parameter	26.5	19.7	13.3	°C/W
Ψ <sub>JB</sub>	Junction-to-board characterization parameter	83.8	95.9	64.4	°C/W
R <sub>θJC(bot)</sub>	Junction-to-case (bottom) thermal resistance	N/A	N/A	42.7	°C/W

(1) For more information about traditional and new thermal metrics, see the [Semiconductor and IC Package Thermal Metrics](#) application note.

### 6.5 Recommended Operating Conditions

over operating free-air temperature range (unless otherwise noted)

		MIN	NOM	MAX	UNIT
V <sub>DD</sub>	Supply voltage	1.62		5.5	V
V <sub>S</sub> or V <sub>D</sub>	Signal path input/output voltage (source or drain pin) (Sx, D)	0		V <sub>DD</sub>	V
V <sub>SEL</sub> or V <sub>EN</sub>	Logic control input pin voltage ( $\overline{\text{EN}}$ , A0, A1, A2)	0		5.5	V
I <sub>S</sub> or I <sub>D (CONT)</sub>	Continuous current through switch (Sx, D pins) –40°C to +85°C	–50		50	mA
I <sub>S</sub> or I <sub>D (CONT)</sub>	Continuous current through switch (Sx, D pins) –40°C to +125°C	–25		25	mA
I <sub>OK</sub>	Current per input into source or drain pins when signal voltage exceeds recommended operating voltage <sup>(1)</sup>	–50		50	mA
I <sub>INJ</sub>	Injected current into single off switch input	–50		50	mA
I <sub>INJ_ALL</sub>	Total injected current into all off switch inputs combined	–100		100	mA
T <sub>A</sub>	Ambient temperature	–40		125	°C

(1) If source or drain voltage exceeds V<sub>DD</sub>, or goes below GND, the pin will be shunted to GND through an internal FET, the current must be limited within the specified value. If V<sub>signal</sub> > V<sub>DD</sub> or if V<sub>signal</sub> < GND.

## 6.6 Electrical Characteristics

At specified  $V_{DD} \pm 10\%$

Typical values measured at nominal  $V_{DD}$

PARAMETER	TEST CONDITIONS	$V_{DD}$	Operating free-air temperature ( $T_A$ )									UNIT
			25°C			–40°C to 85°C			–40°C to 125°C			
			MIN	TYP	MAX	MIN	TYP	MAX	MIN	TYP	MAX	
ANALOG SWITCH												
$R_{ON}$	On-state switch resistance	$V_S = 0V$ to $V_{DD}$ $I_{SD} = 0.5mA$	1.8V	650	1500			1700			1700	$\Omega$
			2.5V	230	600			670			670	
			3.3V	120	330			350			370	
			5V	75	195			220			270	
$\Delta_{RON}$	On-state switch resistance matching between inputs	$V_S = V_{DD} / 2$ $I_{SD} = 0.5mA$	1.8V	10	38			45			45	$\Omega$
			2.5V	3	20			22			22	
			3.3V	2	8			11			15	
			5V	1	7			10			14	
$I_{S(OFF)}$	Source off-state leakage current	Switch Off $V_D = 0.8 \times V_{DD} / 0.2 \times V_{DD}$ $V_S = 0.2 \times V_{DD} / 0.8 \times V_{DD}$	1.8V	$\pm 1$		–25	25	–800	800			nA
			2.5V	$\pm 1$		–25	25	–800	800			
			3.3V	$\pm 1$		–25	25	–800	800			
			5V	$\pm 1$		–25	25	–800	800			
$I_{D(OFF)}$	Drain off-state leakage current (common drain pin)	Switch Off $V_D = 0.8 \times V_{DD} / 0.2 \times V_{DD}$ $V_S = 0.2 \times V_{DD} / 0.8 \times V_{DD}$	1.8V	$\pm 1$		–45	45	–800	800			nA
			2.5V	$\pm 1$		–45	45	–800	800			
			3.3V	$\pm 1$		–45	45	–800	800			
			5V	$\pm 1$		–45	45	–800	800			
$I_{D(ON)}$ $I_{S(ON)}$	Channel on-state leakage current	Switch On $V_D = V_S = 0.8 \times V_{DD}$ or $V_D = V_S = 0.2 \times V_{DD}$	1.8V	$\pm 1$		–45	45	–800	800			nA
			2.5V	$\pm 1$		–45	45	–800	800			
			3.3V	$\pm 1$		–45	45	–800	800			
			5V	$\pm 1$		–45	45	–800	800			
$C_{SOFF}$	Source off capacitance	$V_S = V_{DD} / 2$ $f = 1MHz$	1.8V	2	14			14			14	pF
			2.5V	2	14			14			14	
			3.3V	2	14			14			14	
			5V	2	14			14			14	
$C_{DOFF}$	Drain off capacitance	$V_S = V_{DD} / 2$ $f = 1MHz$	1.8V	7	37			37			37	pF
			2.5V	7	37			37			37	
			3.3V	7	37			37			37	
			5V	7	37			37			37	
$C_{SON}$ $C_{DON}$	On capacitance	$V_S = V_{DD} / 2$ $f = 1MHz$	1.8V	11	40			40			40	pF
			2.5V	11	40			40			40	
			3.3V	11	40			40			40	
			5V	11	40			40			40	
POWER SUPPLY												
$I_{DD}$	$V_{DD}$ supply current	Logic inputs = 0V or $V_{DD}$	1.8V		1			1			1.2	$\mu A$
			2.5V		1			1			1.5	
			3.3V		1			1			2	
			5V		1			1.5			3	

## 6.7 Logic and Dynamic Characteristics

At specified  $V_{DD} \pm 10\%$

Typical values measured at nominal  $V_{DD}$  and  $T_A = 25^\circ\text{C}$ .

PARAMETER	TEST CONDITIONS	$V_{DD}$	Operating free-air temperature ( $T_A$ )			UNIT
			–40°C to 125°C			
			MIN	TYP	MAX	
LOGIC INPUTS ( $\overline{EN}$ , A0, A1, A2)						
$V_{IH}$	Input logic high	1.8V	0.95	5.5	V	
		2.5V	1.1	5.5		
		3.3V	1.15	5.5		
		5V	1.25	5.5		
$V_{IL}$	Input logic low	1.8V	0	0.6	V	
		2.5V	0	0.7		
		3.3V	0	0.8		
		5V	0	0.95		
$I_{IH}$	Logic high input leakage current	$V_{LOGIC} = 1.8\text{V or }V_{DD}$	All		1	uA
$I_{IL}$	Logic low input leakage current	$V_{LOGIC} = 0\text{V}$	All	–1		uA
$C_{IN}$	Logic input capacitance	$V_{LOGIC} = 0\text{V, }1.8\text{V, }V_{DD}$ $f = 1\text{MHz}$	All	1	2	pF
DYNAMIC CHARACTERISTICS						
$Q_{INJ}$	Charge Injection	$V_S = V_{DD} / 2$ $R_S = 0\Omega, C_L = 100\text{pF}$	1.8V	–0.5	pC	
			2.5V	–0.5		
			3.3V	–0.8		
			5V	–1.5		
$O_{ISO}$	Off Isolation	$V_{BIAS} = V_{DD} / 2$ $V_S = 200\text{mVpp}$ $R_L = 50\Omega, C_L = 5\text{pF}$ $f = 100\text{kHz}$	1.8V	–110	dB	
			2.5V	–110		
			3.3V	–110		
			5V	–110		
$O_{ISO}$	Off Isolation	$V_{BIAS} = V_{DD} / 2$ $V_S = 200\text{mVpp}$ $R_L = 50\Omega, C_L = 5\text{pF}$ $f = 1\text{MHz}$	1.8V	–90	dB	
			2.5V	–90		
			3.3V	–90		
			5V	–90		
$X_{TALK}$	Crosstalk	$V_{BIAS} = V_{DD} / 2$ $V_S = 200\text{mVpp}$ $R_L = 50\Omega, C_L = 5\text{pF}$ $f = 100\text{kHz}$	1.8V	–110	dB	
			2.5V	–110		
			3.3V	–110		
			5V	–110		
$X_{TALK}$	Crosstalk	$V_{BIAS} = V_{DD} / 2$ $V_S = 200\text{mVpp}$ $R_L = 50\Omega, C_L = 5\text{pF}$ $f = 1\text{MHz}$	1.8V	–90	dB	
			2.5V	–90		
			3.3V	–90		
			5V	–90		
BW	Bandwidth	$V_{BIAS} = V_{DD} / 2$ $V_S = 200\text{mVpp}$ $R_L = 50\Omega, C_L = 5\text{pF}$	1.8V	350	MHz	
			2.5V	450		
			3.3V	500		
			5V	500		

## 6.8 Timing Characteristics

At specified  $V_{DD} \pm 10\%$

Typical values measured at nominal  $V_{DD}$ .

PARAMETER	TEST CONDITIONS	$V_{DD}$	Operating free-air temperature ( $T_A$ )									UNIT
			25°C			–40°C to 85°C			–40°C to 125°C			
			MIN	TYP	MAX	MIN	TYP	MAX	MIN	TYP	MAX	
SWITCHING CHARACTERISTICS												
$t_{PD}$	Propagation delay	$C_L = 50\text{pF}$ Sx to D, D to Sx	1.8V	15	30			30			30	ns
			2.5V	8	15			20			20	
			3.3V	5	11			15			15	
			5V	4	9			10			10	
		CL = 15pF	5V	1.5	4			5			5	
$t_{TRAN}$	Transition-time between inputs	$R_L = 10\text{k}\Omega$ , $C_L = 50\text{pF}$ Ax to D, Ax to Sx	1.8V	44	94			103			103	ns
			2.5V	30	63			67			67	
			3.3V	23	51			54			54	
			5V	18	43			46			46	
		$R_L = 10\text{k}\Omega$ , $C_L = 15\text{pF}$	5V	15	39			43			43	
$t_{ON(EN)}$	Turnon-time from enable	$R_L = 10\text{k}\Omega$ , $C_L = 50\text{pF}$ EN to D, EN to Sx	1.8V	39	68			75			75	ns
			2.5V	30	48			50			50	
			3.3V	26	40			42			42	
			5V	24	34			37			37	
		$R_L = 10\text{k}\Omega$ , $C_L = 15\text{pF}$	5V	22	31			35			35	
$t_{OFF(EN)}$	Turnoff time from enable	$R_L = 10\text{k}\Omega$ , $C_L = 50\text{pF}$ EN to D, EN to Sx	1.8V	60	80			85			85	ns
			2.5V	50	70			72			72	
			3.3V	40	65			70			70	
			5V	28	50			55			55	
		$R_L = 10\text{k}\Omega$ , $C_L = 15\text{pF}$	5V	23	30			35			35	
$t_{BBM}$	Break before make time	$R_L = 10\text{k}\Omega$ , $C_L = 15\text{pF}$ Sx to D, D to Sx	1.8V	1	16		1		1			ns
			2.5V	1	22		1		1			
			3.3V	1	24		1		1			
			5V	1	33		1		1			

## 6.9 Injection Current Coupling

At specified  $V_{DD} \pm 10\%$

Typical values measured at nominal  $V_{DD}$  and  $T_A = 25^\circ\text{C}$ .

PARAMETER	$V_{DD}$	TEST CONDITIONS		-40°C to 125°C			UNIT
				MIN	TYP	MAX	
<b>INJECTION CURRENT COUPLING</b>							
$\Delta V_{OUT}$	Maximum shift of output voltage of enabled analog input	1.8V	$R_S \leq 3.9\text{k}\Omega$	$I_{INJ} \leq 1\text{mA}$	0.01	1	mV
		3.3V			0.05	1	
		5V			0.1	1	
		1.8V	$R_S \leq 3.9\text{k}\Omega$	$I_{INJ} \leq 10\text{mA}$	0.01	2	
		3.3V			0.3	3	
		5V			0.06	4	
		1.8V	$R_S \leq 20\text{k}\Omega$	$I_{INJ} \leq 1\text{mA}$	0.05	2	
		3.3V			0.05	2	
		5V			0.1	2	
		1.8V	$R_S \leq 20\text{k}\Omega$	$I_{INJ} \leq 10\text{mA}$	0.05	15	
		3.3V			0.05	15	
		5V			0.02	15	

## 6.10 Typical Characteristics

at  $T_A = 25^\circ\text{C}$ ,  $V_{DD} = 5\text{V}$  (unless otherwise noted)

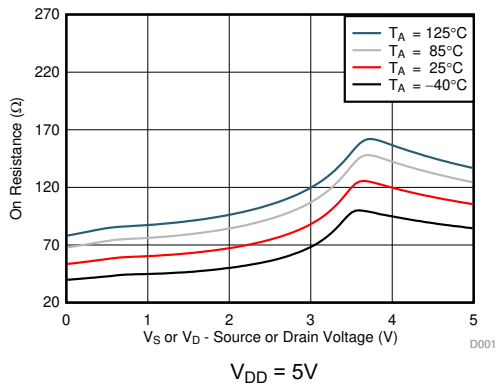

Figure 6-1. On-Resistance vs Temperature

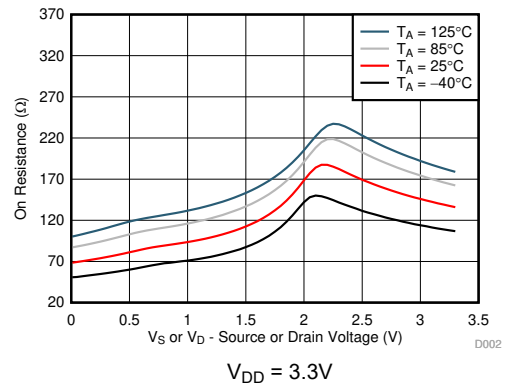

Figure 6-2. On-Resistance vs Temperature

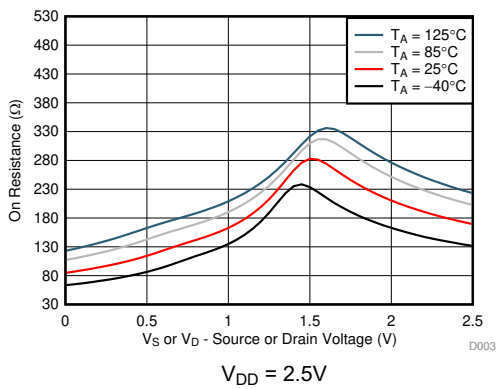

Figure 6-3. On-Resistance vs Temperature

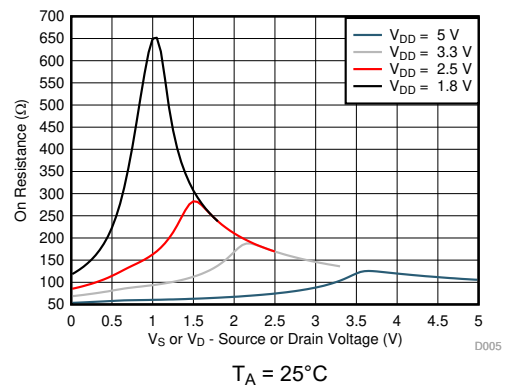

Figure 6-4. On-Resistance vs Source or Drain Voltage

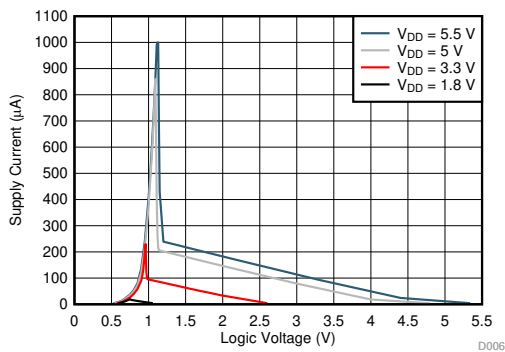

Figure 6-5. Supply Current vs Logic Voltage

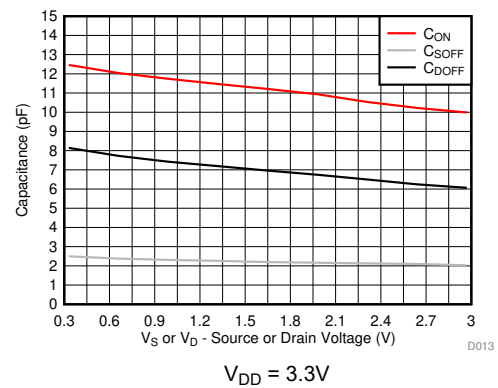

Figure 6-6. Capacitance vs Source Voltage

### 6.10 Typical Characteristics (continued)

at  $T_A = 25^\circ\text{C}$ ,  $V_{DD} = 5\text{V}$  (unless otherwise noted)

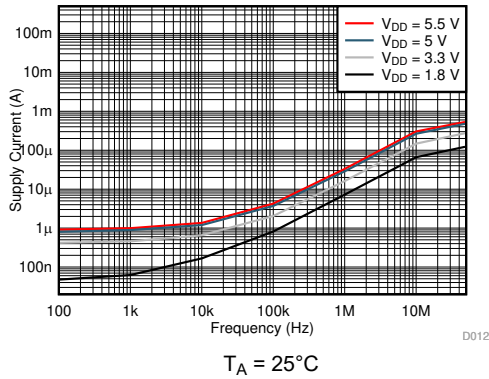

Figure 6-7. Supply Current vs Input Switching Frequency

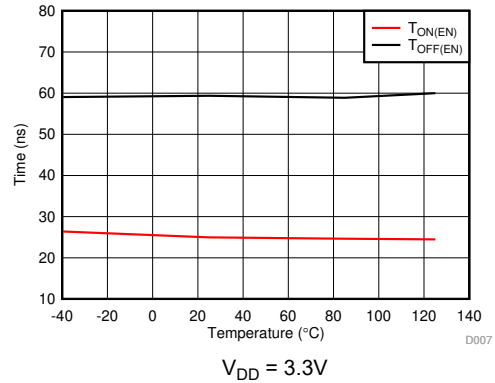

Figure 6-8.  $T_{ON(EN)}$  and  $T_{OFF(EN)}$  vs Temperature

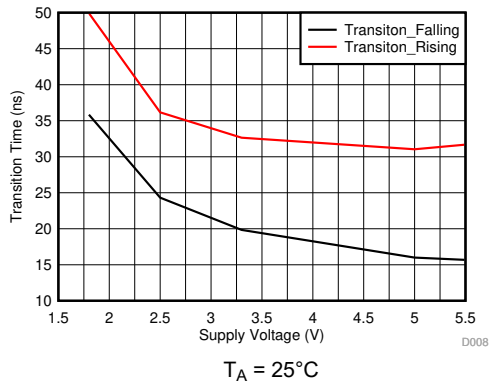

Figure 6-9.  $T_{TRANSITION}$  vs Supply Voltage

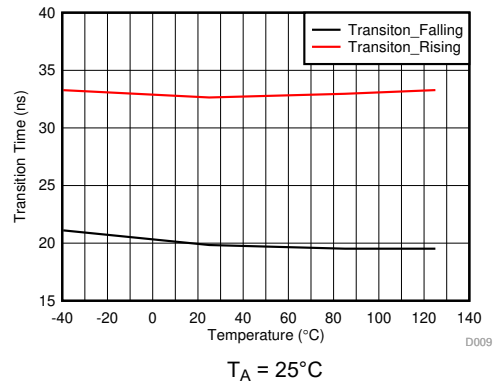

Figure 6-10.  $T_{TRANSITION}$  vs Temperature

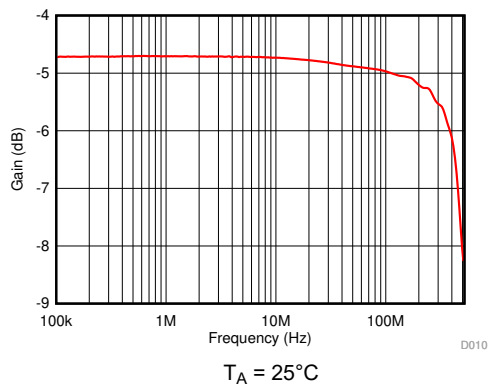

Figure 6-11. On Response vs Frequency

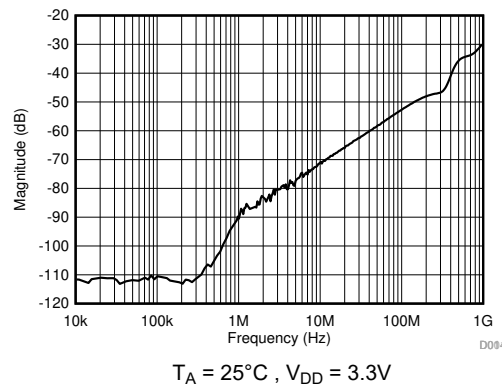
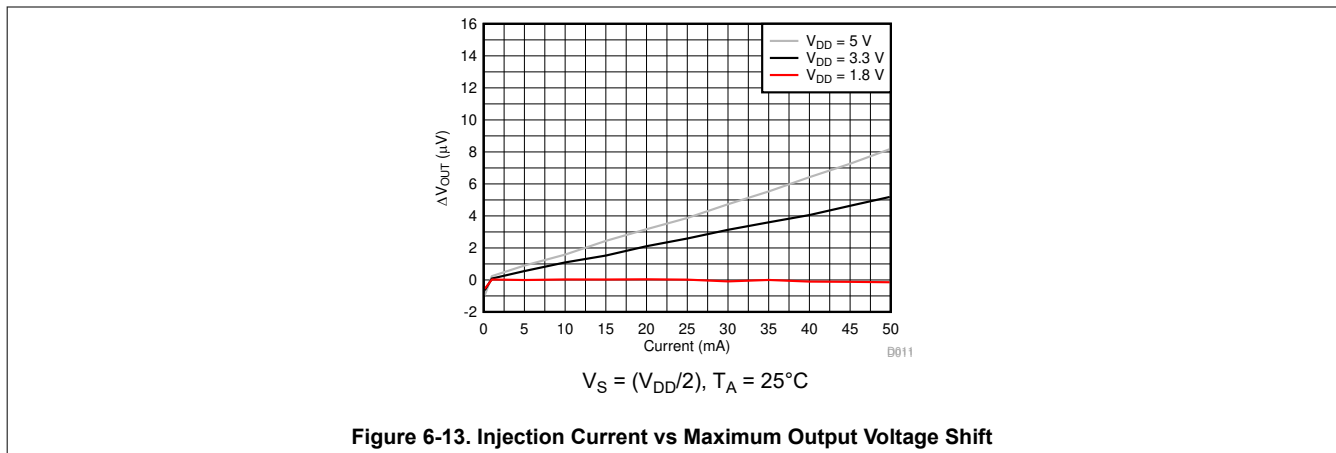

Figure 6-12. Xtalk and Off-Isolation vs Frequency

## 6.10 Typical Characteristics (continued)

at  $T_A = 25^\circ\text{C}$ ,  $V_{DD} = 5\text{V}$  (unless otherwise noted)



## 7 Parameter Measurement Information

### 7.1 On-Resistance

The on-resistance of a device is the ohmic resistance between the source (Sx) and drain (D) pins of the device. The on-resistance varies with input voltage and supply voltage. The symbol  $R_{ON}$  is used to denote on-resistance. The measurement setup used to measure  $R_{ON}$  is shown in the following figure. Voltage (V) and current ( $I_{SD}$ ) are measured using this setup, and  $R_{ON}$  is computed as shown in Figure 7-1 with  $R_{ON} = V / I_{SD}$ :

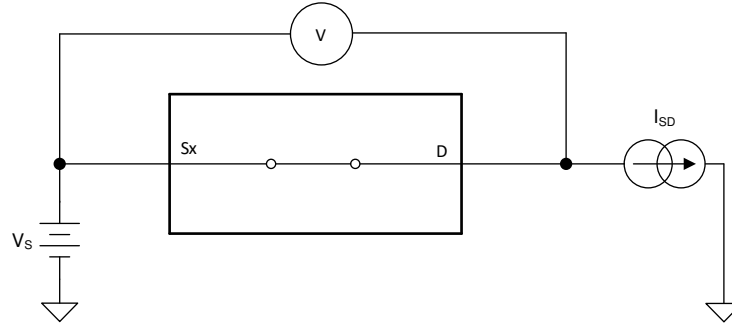

**Figure 7-1. On-Resistance Measurement Setup**

### 7.2 Off-Leakage Current

There are two types of leakage currents associated with a switch during the off state:

1. Source off-leakage current.
2. Drain off-leakage current.

Source leakage current is defined as the leakage current flowing into or out of the source pin when the switch is off. This current is denoted by the symbol  $I_{S(OFF)}$ .

Drain leakage current is defined as the leakage current flowing into or out of the drain pin when the switch is off. This current is denoted by the symbol  $I_{D(OFF)}$ .

Figure 7-2 shows the setup used to measure both off-leakage currents.

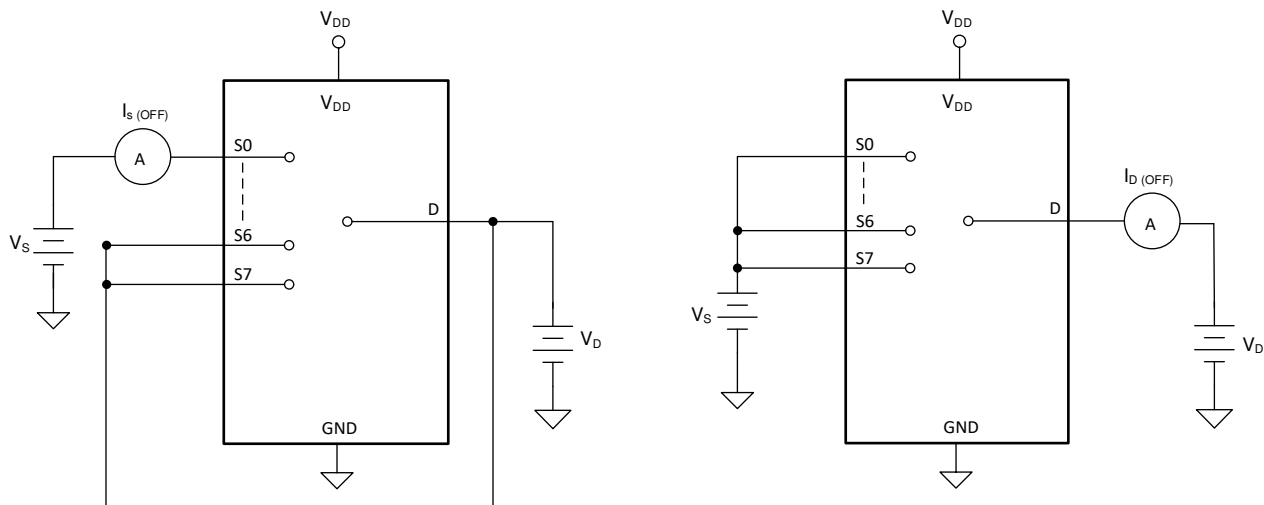

**Figure 7-2. Off-Leakage Measurement Setup**

### 7.3 On-Leakage Current

Source on-leakage current is defined as the leakage current flowing into or out of the source pin when the switch is on. This current is denoted by the symbol  $I_{S(ON)}$ .

Drain on-leakage current is defined as the leakage current flowing into or out of the drain pin when the switch is on. This current is denoted by the symbol  $I_{D(ON)}$ .

Either the source pin or drain pin is left floating during the measurement. Figure 7-3 shows the circuit used for measuring the on-leakage current, denoted by  $I_{S(ON)}$  or  $I_{D(ON)}$ .

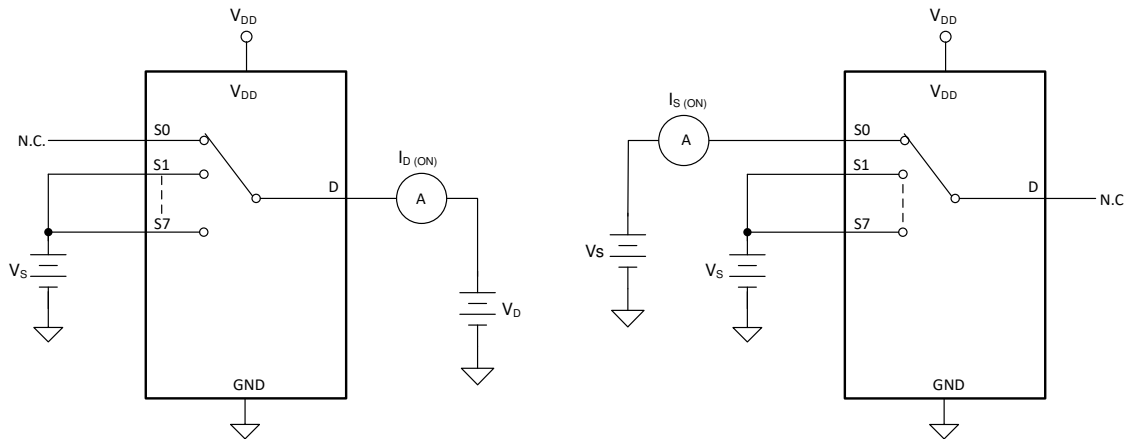

Figure 7-3. On-Leakage Measurement Setup

### 7.4 Transition Time

Transition time is defined as the time taken by the output of the device to rise or fall 50% after the address signal has risen or fallen past the 50% threshold. Figure 7-4 shows the setup used to measure transition time, denoted by the symbol  $t_{TRANSITION}$ .

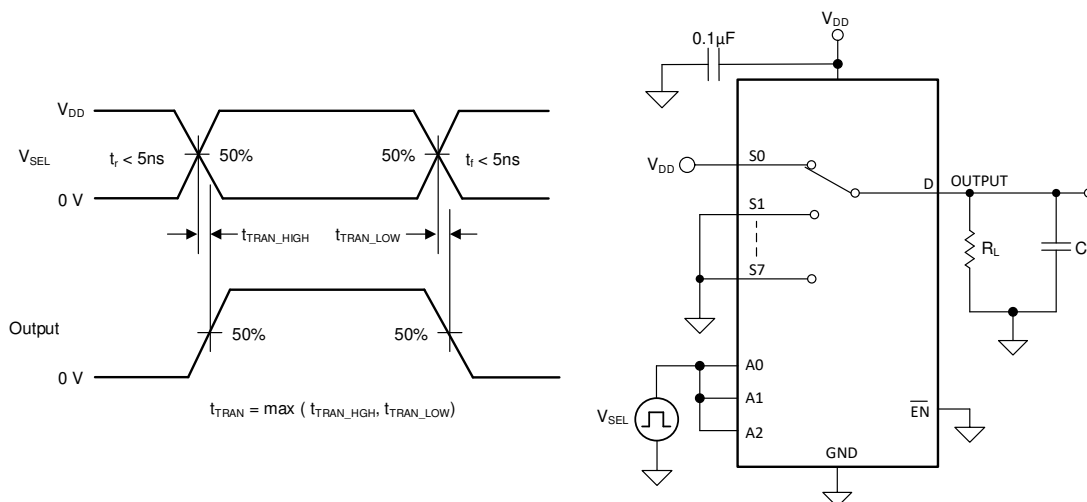
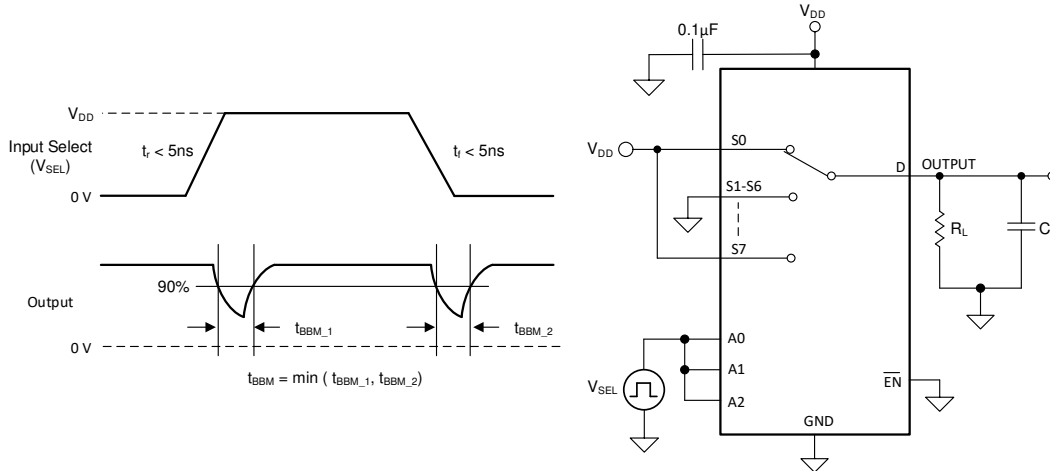

Figure 7-4. Transition-Time Measurement Setup

### 7.5 Break-Before-Make

Break-before-make delay is a safety feature that prevents two inputs from connecting when the device is switching. The output first breaks from the on-state switch before making the connection with the next on-state switch. The time delay between the *break* and the *make* is known as break-before-make delay. Figure 7-5 shows the setup used to measure break-before-make delay, denoted by the symbol  $t_{OPEN(BBM)}$ .

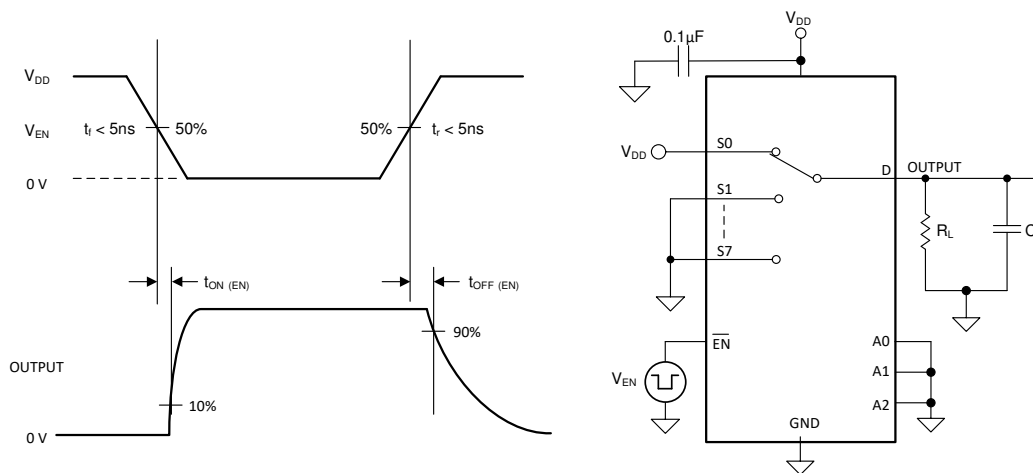

**Figure 7-5. Break-Before-Make Delay Measurement Setup**

### 7.6 $t_{ON(EN)}$ and $t_{OFF(EN)}$

Turn-on time is defined as the time taken by the output of the device to rise to 10% after the enable has risen past the 50% threshold. The 10% measurement is utilized to provide the timing of the device, system level timing can then account for the time constant added from the load resistance and load capacitance. Figure 7-6 shows the setup used to measure transition time, denoted by the symbol  $t_{ON(EN)}$ .

Turn-off time is defined as the time taken by the output of the device to fall to 90% after the enable has fallen past the 50% threshold. The 90% measurement is utilized to provide the timing of the device, system level timing can then account for the time constant added from the load resistance and load capacitance. Figure 7-6 shows the setup used to measure transition time, denoted by the symbol  $t_{OFF(EN)}$ .



**Figure 7-6. Turn-On and Turn-Off Time Measurement Setup**

## 7.7 Charge Injection

The TMUX1308A-Q1 and TMUX1309A-Q1 device have a transmission-gate topology. Any mismatch in capacitance between the NMOS and PMOS transistors results in a charge injected into the drain or source during the falling or rising edge of the gate signal. The amount of charge injected into the source or drain of the device is known as charge injection, and is denoted by the symbol  $Q_C$ . Figure 7-7 shows the setup used to measure charge injection from source ( $S_x$ ) to drain (D).

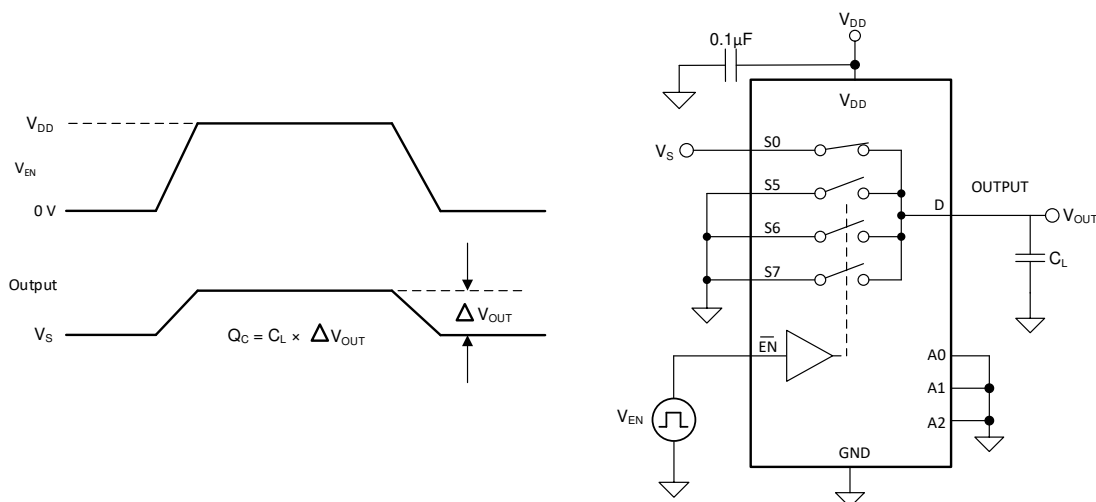

Figure 7-7. Charge-Injection Measurement Setup

## 7.8 Off Isolation

Off isolation is defined as the ratio of the signal at the drain pin (D) of the device when a signal is applied to the source pin ( $S_x$ ) of an off-channel. Figure 7-8 shows the setup used to measure, and the equation to compute off isolation.

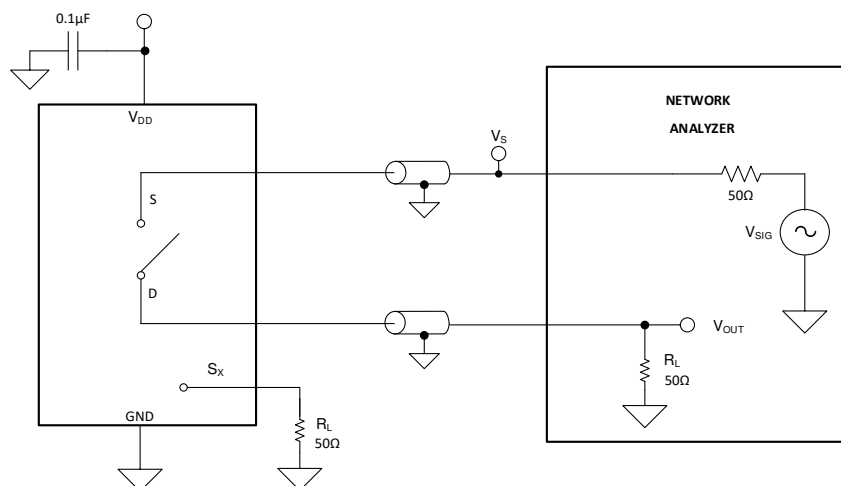
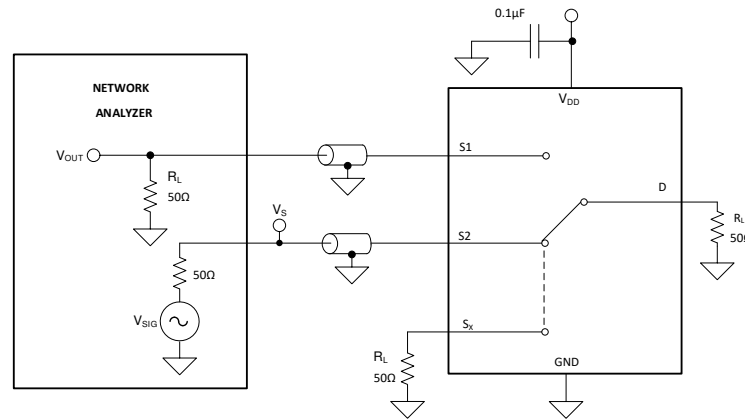

Figure 7-8. Off Isolation Measurement Setup

$$\text{Off Isolation} = 20 \times \text{Log} \left( \frac{V_{OUT}}{V_S} \right) \quad (1)$$

## 7.9 Crosstalk

Crosstalk is defined as the ratio of the signal at the drain pin (D) of a different channel, when a signal is applied at the source pin (Sx) of an on-channel. [Figure 7-9](#) shows the setup used to measure, and the equation used to compute crosstalk.

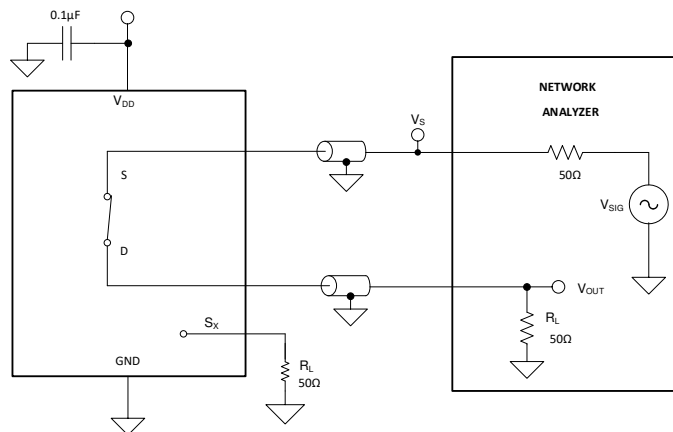

**Figure 7-9. Channel-to-Channel Crosstalk Measurement Setup**

$$\text{Channel-to-Channel Crosstalk} = 20 \times \text{Log} \left( \frac{V_{OUT}}{V_S} \right) \quad (2)$$

## 7.10 Bandwidth

Bandwidth is defined as the range of frequencies that are attenuated by less than 3dB when the input is applied to the source pin (Sx) of an on-channel, and the output is measured at the drain pin (D) of the device. [Figure 7-10](#) shows the setup used to measure bandwidth.

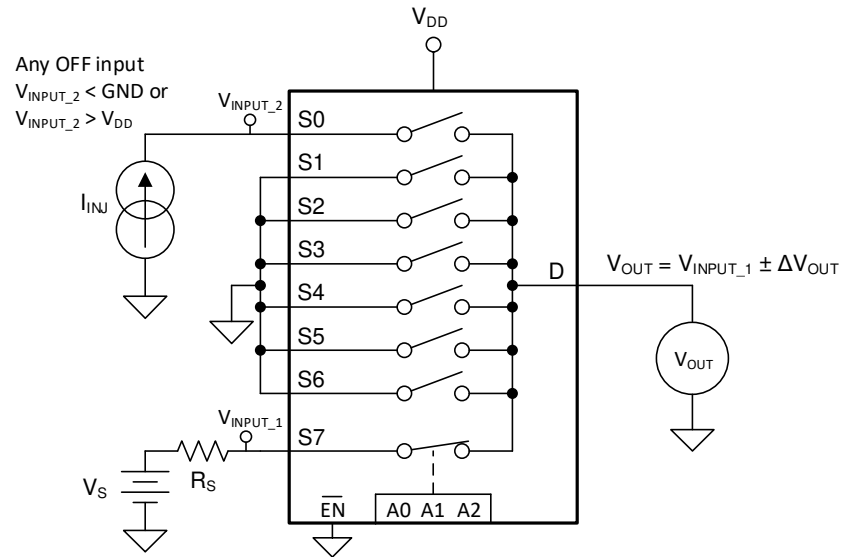

**Figure 7-10. Bandwidth Measurement Setup**

$$\text{Attenuation} = 20 \times \text{Log} \left( \frac{V_2}{V_1} \right) \quad (3)$$

## 7.11 Injection Current Control

Injection current is measured at the change in output of the enabled signal path when a current is injected into a disabled signal path. [Figure 7-11](#) shows the setup used to measure injection current control.



**Figure 7-11. Injection Current Measurement Setup**

## 8 Detailed Description

### 8.1 Overview

The TMUX1308A-Q1 is an 8:1, single-ended (1-channel), mux. The TMUX1309A-Q1 is a 4:1, differential (2-channel) mux. Each channel is turned on or turned off based on the state of the address lines and enable pin.

### 8.2 Functional Block Diagram

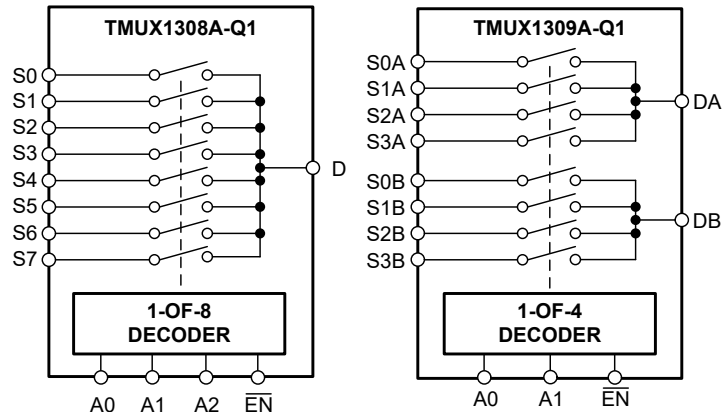

### 8.3 Feature Description

#### 8.3.1 Bidirectional Operation

The TMUX1308A-Q1 and TMUX1309A-Q1 devices conduct equally well from source (Sx) to drain (Dx) or from drain (Dx) to source (Sx). Each signal path has very similar characteristics in both directions so they can be used as both multiplexers and demultiplexer to support both analog and digital signals.

#### 8.3.2 Rail-to-Rail Operation

The valid signal path input and output voltage for the TMUX1308A-Q1 and TMUX1309A-Q1 ranges from GND to  $V_{DD}$ .

#### 8.3.3 1.8V Logic Compatible Inputs

The TMUX1308A-Q1 and TMUX1309A-Q1 support 1.8V logic compatible control for all logic control inputs. The logic input thresholds scale with supply but still provide 1.8V logic control when operating at 5.5V supply voltage. 1.8V logic level inputs allows the multiplexers to interface with processors that have lower logic I/O rails and eliminates the need for an external voltage translator, which saves both space and BOM cost. The current consumption of the TMUX1308A-Q1 and TMUX1309A-Q1 devices increase when using 1.8V logic with higher supply voltage. For more information on 1.8V logic implementations, refer to [Simplifying Design with 1.8V logic Muxes and Switches](#).

#### 8.3.4 Fail-Safe Logic

The TMUX1308A-Q1 and TMUX1309A-Q1 device have Fail-Safe Logic on the control input pins (EN, A0, A1, and A2) allowing for operation up to 5.5V, regardless of the state of the supply pin. This feature allows voltages on the control pins to be applied before the supply pin, protecting the device from potential damage. Fail-Safe Logic minimizes system complexity by removing the need for power supply sequencing on the logic control pins. For example, the Fail-Safe Logic feature allows the select pins of the TMUX1308A-Q1 and TMUX1309A-Q1 to be ramped to 5.5V while  $V_{DD} = 0V$ . Additionally, the feature enables operation of the multiplexers with  $V_{DD} = 1.8V$  while allowing the select pins to interface with a logic level of another device up to 5.5V, eliminating the potential need for an external voltage translator.

### 8.3.5 High-Impedance Optimization

TMUX1308A-Q1 and TMUX1309A-Q1 are optimized for high-impedance loads. When a switch input is connected to a high-impedance output the RC on the input side can cause the output to settle slower. Reducing this RC is one way to make the settling time quicker. Multiplexers can also have an impact on how long it takes for the output to settle through charge injection. When the switch is turning ON, a higher charge injection can cause the source to be pulled away from the desired settling voltage. This means that the output will need to rise or fall further than anticipated causing additional settling time. In the following figure,  $R = 47k\Omega$  and the circuit is tested with different devices, which shows how dependent the settling time can be on the device chosen.

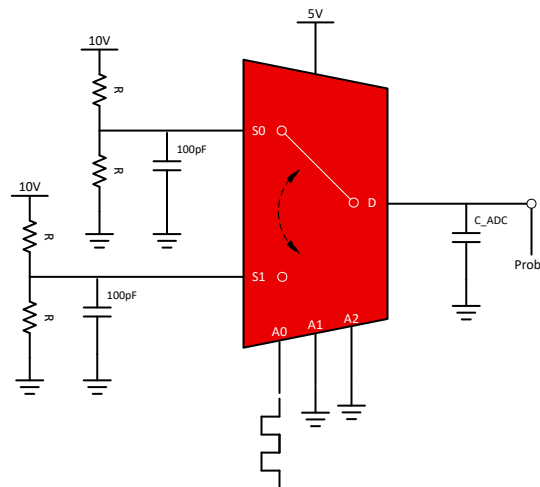

Figure 8-1. Test Circuit Setup

### 47kΩ Settling Time

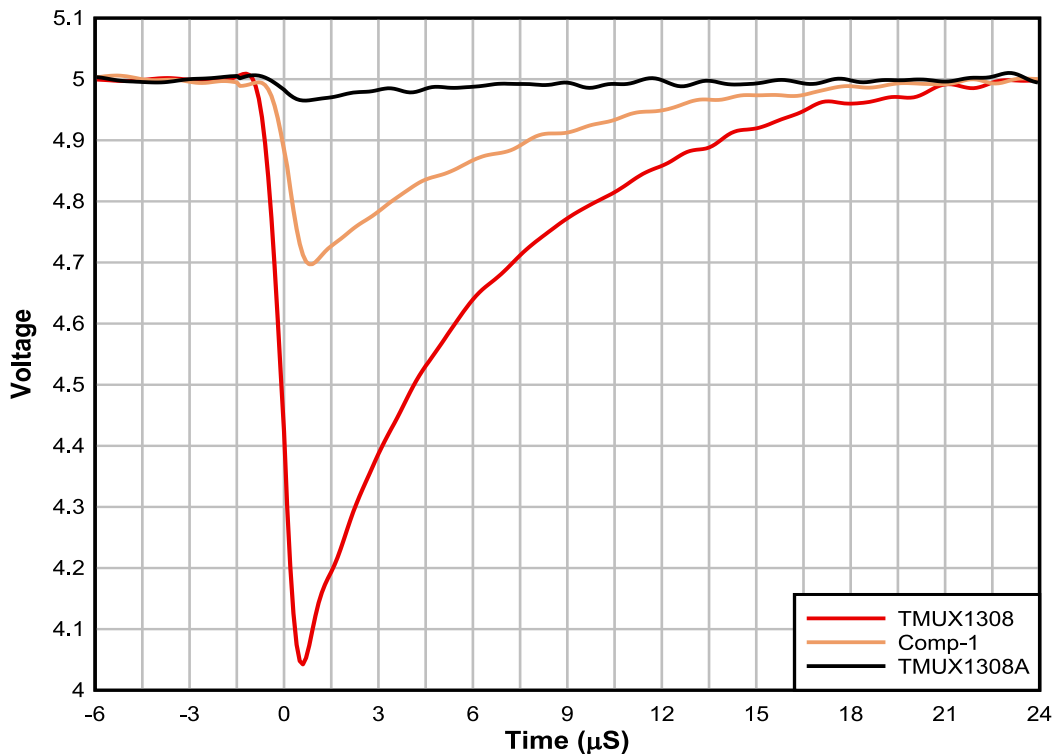

Figure 8-2. TMUX1308A vs. Competition Devices Drain Settling Times

### 8.3.6 Injection Current Control

Injection current is the current that is being forced into a pin by an input voltage ( $V_{IN}$ ) higher than the positive supply ( $V_{DD} + \Delta V$ ) or lower than ground ( $V_{SS}$ ). The current flows through the input protection diodes into whichever supply of the device is potentially compromising the accuracy and reliability of the system. Injected currents can come from various sources depending on the application.

- Harsh environments and applications with long cabling, such as in factory automation and automotive systems, may be susceptible to injected currents from switching or transient events.
- Other self-contained systems can also be subject to injected current if the input signal is coming from various sensors or current sources.

**Injected Current Impact:** typical CMOS switches have ESD protection diodes on the inputs and outputs. These diodes not only serve as ESD protection but also provide a voltage clamp to prevent the inputs or outputs going above  $V_{DD}$  or below  $GND$  and  $V_{SS}$ . When current is injected into the pin of a disabled signal path, a small amount of current goes through the ESD diode but most of the current goes through conduction to the drain. If forward diode voltage of the ESD diode ( $V_F$ ) is greater than the PMOS threshold voltage ( $V_T$ ), then the PMOS of all OFF switches turns ON and there would be undesirable sub threshold leakage between the source and the drain that can lift the OFF source pins up also. [Figure 8-3](#) shows a simplified diagram of a typical CMOS switch and associated injected current path.

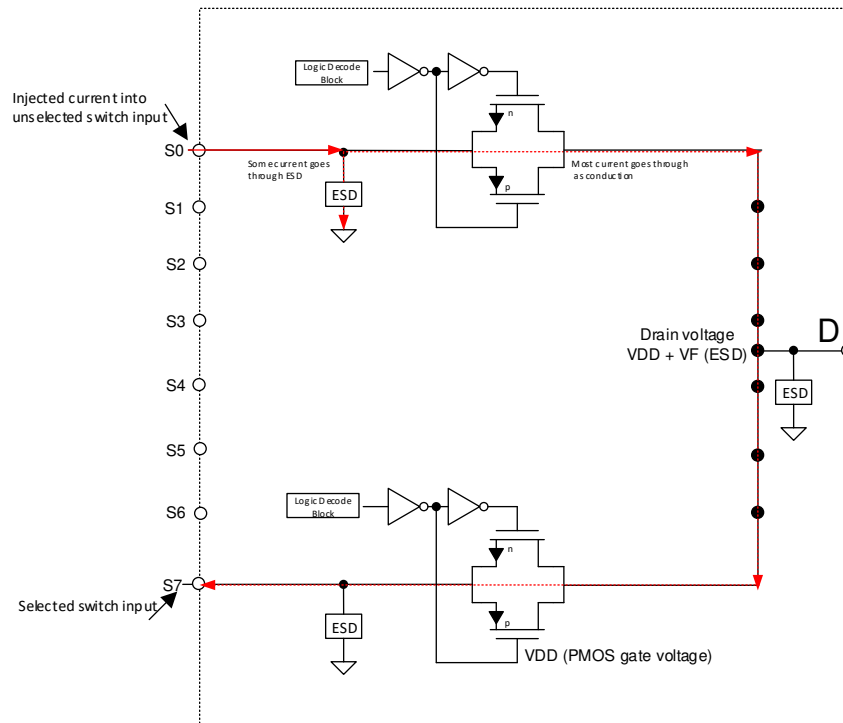

**Figure 8-3. Simplified Diagram of Typical CMOS Switch and Associated Injected Current Path**

It is quite difficult to cut off these current paths. The drain pin can never be allowed to exceed the voltage above  $V_{DD}$  by more than a  $V_T$ . Analog pins can be protected against current injection by adding external components like a Schottky diode from the drain pin to ground to clamp the drain voltage at  $< V_{DD} + V_T$  and cut off the current path.

**Change in  $R_{ON}$  due to Current Injection:** because the ON resistance of the enabled FET switch is impacted by the change in the supply rail, when the drain pin voltage exceeds the supply voltage by more than a  $V_T$ , an error in the output signal voltage can be expected. This undesired change in the output can cause issues related to false trigger events and incorrect measurement readings, potentially compromising the accuracy and reliability of the system. As shown in Figure 8-4, S2 is the enabled signal path that is conducting a signal from S2 pin to D pin. Because there is an injected current at the disabled S1 pin, the voltage at that pin increases above the supply voltage and the ESD protection diode is forward biased, shifting the power supply rail. This shift in supply voltage alters the  $R_{ON}$  of the internal FET switches, causing a  $\Delta V$  error on the output at the D pin.

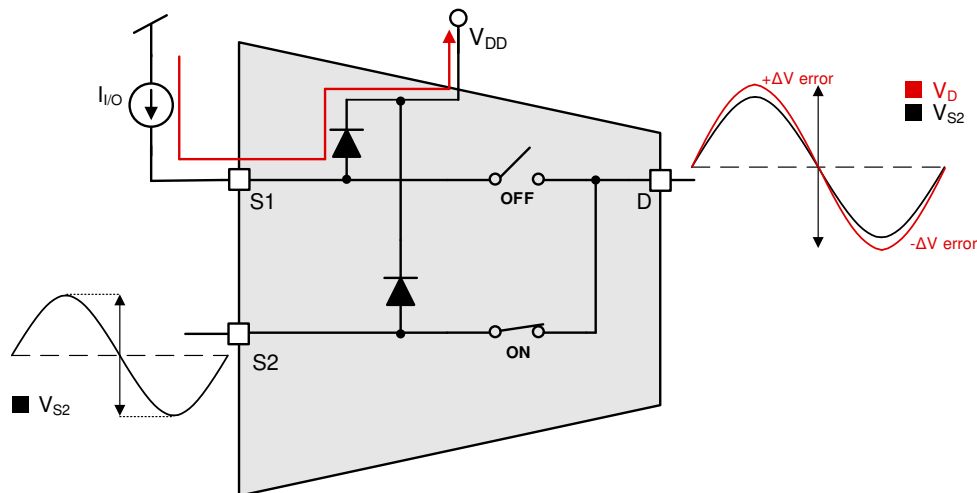

Figure 8-4. Injected Current Impact on  $R_{ON}$

To avoid the complications of added external protection to your system, the TMUX1308A-Q1 and TMUX1309A-Q1 devices have an internal injection current control feature which eliminates the need for external diode and resistor networks typically used to protect the switch and keep the input signals within the supply voltage. The internal injection current control circuitry allows the signals on the disabled signal paths to exceed the supply voltage without affecting the signal of the enabled signal path. The injection current control circuitry also protects the TMUX13xxA-Q1 from currents injected into disabled signal paths without impacting the enabled signal path, which typical CMOS switches do not support. Additionally, the TMUX1308A-Q1 and TMUX1309A-Q1 do not have any internal diode paths to the supply pin, which eliminates the risk of damaging components connected to the supply pin or providing unintended power to the system supply rail. For a simplified diagram that shows one signal path for the TMUX13xxA-Q1 devices and the associated injection current circuit, refer to Section 8.2.

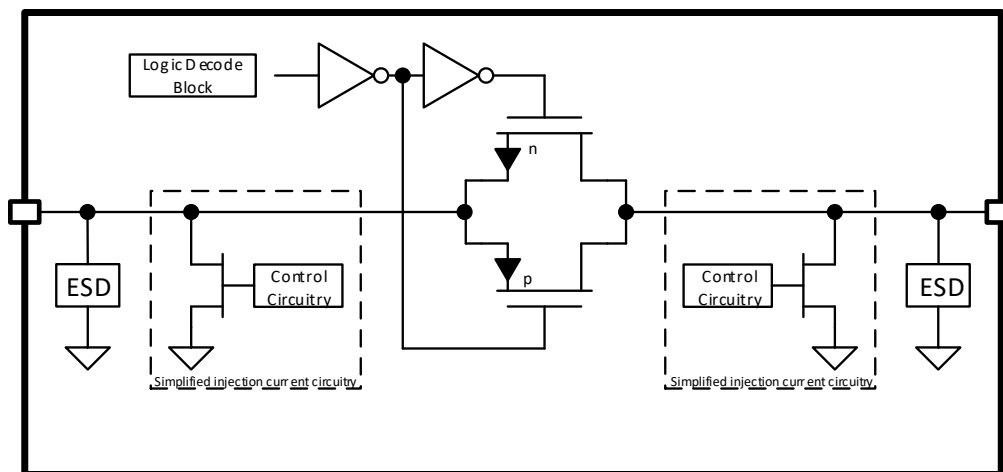

Figure 8-5. Simplified Diagram of Injection Current Control

The injection current control circuitry is independently controlled for each source or drain pin (Sx or D). The control circuitry for a particular pin is enabled when that input is disabled by the logic pins and the injected current causes the voltage at the pin to be above  $V_{DD}$  or below GND. The injection current circuit includes an FET to shunt the undesired current to GND in the case of overvoltage or injected current events. Each injection current circuit is rated to handle up to 50mA; the device, however, can support a maximum current of 100mA at any given time. Depending on the system application, a series limiting resistor may be needed and must be sized appropriately. Figure 8-5 shows the TMUX13xxA-Q1 protection circuitry with an injected current at an input pin.

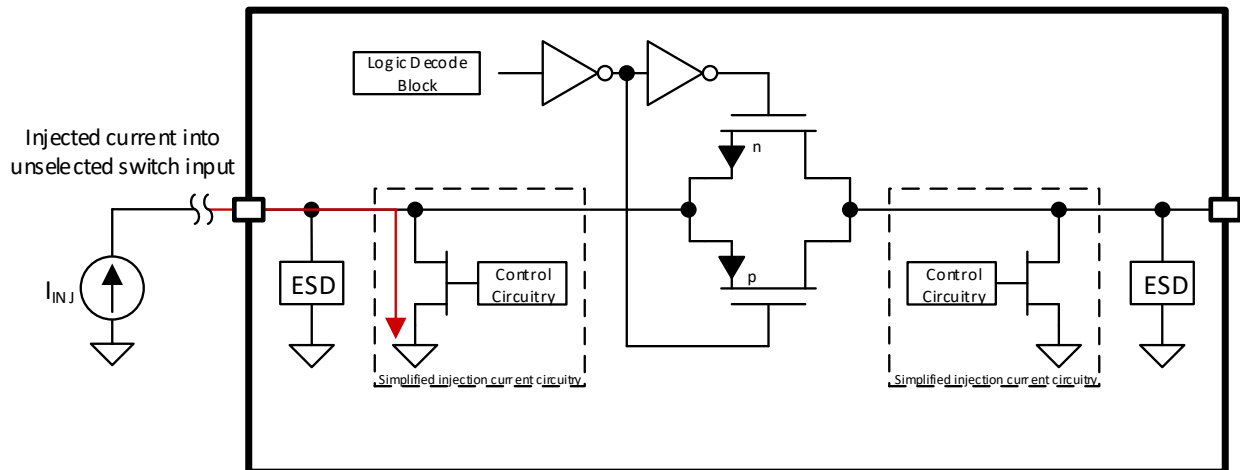

Figure 8-6. Injected Current at Input Pin

Figure 8-7 shows an example of using a series limiting resistor in the case of an overvoltage event.

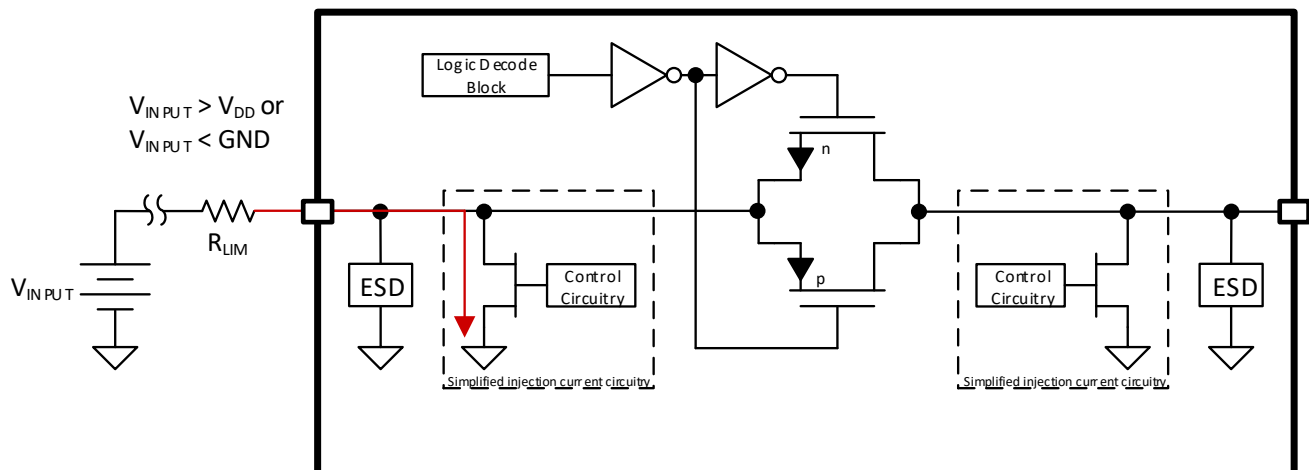

Figure 8-7. Over-Voltage Event with Series Resistor

For the injection current control circuitry to be active, two conditions must be present. First, the voltage at the source or drain pins is greater than  $V_{DD}$ , or less than GND. Next, the channel must be unselected. With those two requirements met, the protection FET will be turned on for any disabled signal path and shunt the pin to GND. In this event, a series resistor is needed to limit the total current injected into the device to be less than 100mA. Three example scenarios are outlined in the following sections.

#### 8.3.6.1 TMUX13xxA-Q1 is Powered, Channel is Unselected, and the Input Signal is Greater Than $V_{DD}$ ( $V_{DD} = 5V$ , $V_{INPUT} = 5.5V$ )

A typical CMOS switch would have an internal ESD diode to the supply pin rated for  $\approx 30mA$  that would be turned on and a series limited resistor would be needed. However, any conducted current would be injected into the supply rail potentially damaging the system, unexpectedly turning on other devices on the same supply rail, or requiring additional components for protection. The TMUX13xxA-Q1 implementation also handles this scenario with a series limiting resistor; the current path, however, is now to GND which does not have the same issues as the current injected into the supply rail.

#### 8.3.6.2 TMUX13xxA-Q1 is Powered, Channel is Selected, and the Input Signal is Greater Than $V_{DD}$ ( $V_{DD} = 5V$ , $V_{INPUT} = 5.5V$ )

The injection current control circuitry is fully active when the channel is unselected and an overvoltage event is present (overvoltage being defined as 0.5V above the supply rail). However, in situations where the channel is selected and an overvoltage event occurs, this protection circuitry will still be partially active. In this instance, a portion of the injected current will be redirected through the protection circuitry to GND, but will not be a full shunt. So, some current will also flow through the source to drain path. This allows the device to tolerate overvoltage conditions in the event of the channel being selected, but precautions are still necessary to protect the device from overcurrent events such as implementing a current limiting resistor to keep the device below the maximum continuous source and drain current specification.

#### 8.3.6.3 TMUX13xxA-Q1 is Unpowered and the Input Signal has a Voltage Present ( $V_{DD} = 0V$ , $V_{INPUT} = 3V$ )

Many CMOS switches are unable to support a voltage at the input without a valid supply voltage present, otherwise the voltage will be coupled from input to output and could damage downstream devices or impact power-sequencing. The TMUX13xxA-Q1 circuitry can handle an input signal present without a supply voltage while minimizing power transfer from the input to output of the switch. By limiting the output voltage coupling to 400mV the TMUX1308A-Q1 and TMUX1309A-Q1 help reduce the chance of conduction through any downstream ESD diodes.

## 8.4 Device Functional Modes

When the  $\overline{EN}$  pin of the TMUX1308A-Q1 is pulled low, one of the switches is closed based on the state of the address lines. Similarly, when the  $\overline{EN}$  pin of the TMUX1309A-Q1 is pulled low, two of the switches are closed based on the state of the address lines. When the  $\overline{EN}$  pin is pulled high, all the switches are in an open state regardless of the state of the address lines.

Unused logic control pins must be tied to GND or  $V_{DD}$  so that the device does /not consume additional current as highlighted in [Implications of Slow or Floating CMOS Inputs](#). Unused signal path inputs (Sx and Dx) should be connected to GND.

## 8.5 Truth Tables

Table 8-1 and Table 8-2 provides the truth tables for the TMUX1308A-Q1 and TMUX1309A-Q1 respectively.

**Table 8-1. TMUX1308A-Q1 Truth Table**

EN	A2	A1	A0	Selected Signal Path Connected To Drain (D) Pin
0	0	0	0	S0
0	0	0	1	S1
0	0	1	0	S2
0	0	1	1	S3
0	1	0	0	S4
0	1	0	1	S5
0	1	1	0	S6
0	1	1	1	S7
1	X <sup>(1)</sup>	X <sup>(1)</sup>	X <sup>(1)</sup>	All channels are off

(1) X denotes *do not care*.

**Table 8-2. TMUX1309A-Q1 Truth Table**

$\overline{\text{EN}}$	A1	A0	Selected Signal Path Connected To Drain (DA and DB) Pins
0	0	0	S0A to DA S0B to DB
0	0	1	S1A to DA S1B to DB
0	1	0	S2A to DA S2B to DB
0	1	1	S3A to DA S3B to DB
1	X <sup>(1)</sup>	X <sup>(1)</sup>	All channels are off

(1) X denotes *do not care*.

## 9 Application and Implementation

### Note

Information in the following applications sections is not part of the TI component specification, and TI does not warrant its accuracy or completeness. TI's customers are responsible for determining suitability of components for their purposes. Customers should validate and test their design implementation to confirm system functionality.

### 9.1 Application Information

The TMUX13xxA-Q1 family offers protection against injection current events across a wide operating supply range (1.62V to 5.5V). These devices include 1.8V logic compatible control input pins that enable operation in systems with 1.8V I/O rails. Additionally, the control input pins support Fail-Safe Logic which allows for operation up to 5.5V, regardless of the state of the supply pin. This feature stops the logic pins from back-powering the supply rail while the injection current circuitry prevents the signal path from back-powering the supply. These features make the TMUX13xxA-Q1 a family of general purpose multiplexers and switches that can reduce system complexity, board size, and overall system cost.

### 9.2 Typical Application

One useful application that takes advantage of the TMUX13xxA-Q1 features is multiplexing various physical switches in a body control module (BCM) or electronic control unit (ECU). Automotive BCMs are complex systems designed to manage numerous functions such as lighting, door locks, windows, wipers, turn signals, and many more inputs. The BCM monitors these physical switches and controls power to various loads within the vehicle. A CMOS multiplexer can be used to multiplex the inputs and minimize the number of GPIO or ADC inputs needed by an on board MCU.

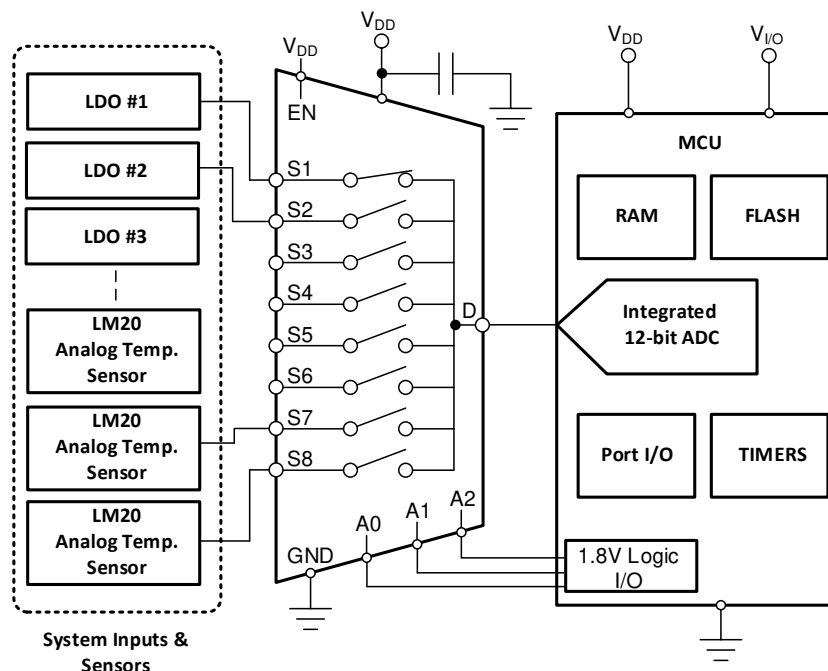

**Figure 9-1. Multiplexing Signals to Integrated ADC**

### 9.2.1 Design Requirements

For this design example, use the parameters listed in [Table 9-1](#).

**Table 9-1. Design Parameters**

PARAMETERS	VALUES
Supply ( $V_{DD}$ )	5.0V
I/O signal range	0V to $V_{DD}$ (Rail to Rail)
Control logic thresholds	1.8V compatible
Switch inputs	Eight

### 9.2.2 Detailed Design Procedure

The TMUX1308A-Q1 has an internal Injection current control, which eliminates the need for external diode or resistor networks typically used to protect the switch and keep the input signals within the supply voltage (for more information see, [Section 8.3.6](#)). The internal injection current control circuitry allows signals on disabled signal paths to exceed the supply voltage without affecting the signal of the enabled signal path. Injected currents can come from various sources such as from long cabling in automotive systems that may be susceptible to induced currents from switching or transient events.

Another momentary source of injected currents in BCMs are wetting currents, which are small currents used to prevent oxidation on metal switch contacts or wires. A switch without injection current control can have the measured output of the enabled signal path impacted if a current is injected into a disabled signal path. This undesired change in the output can cause issues related to false trigger events and incorrect measurement readings which can compromise the accuracy and reliability of the BCM system.

The BCM uses the 12V battery voltage to provide a wetting current to each switch when the associated control circuitry is enabled by the micro controller. The wetting current is sized by the  $R_{WETT}$  and the required value may vary depending on the type of physical switch being monitored. The 20k $\Omega$  and 15k $\Omega$  resistors are used in addition to the wetting resistor to create a voltage divider before the input of the multiplexer in case of a short-to-battery condition. The resistor values are selected to maintain the voltage at the switch signal path below VDD. The 20k $\Omega$  series resistor also limits the amount of injected current into the switch if an overvoltage event occurs. Diodes D1 through D8 are used to prevent back flow of current in case a secondary system is monitoring the same physical switches for backup or redundancy reasons. The 10nF capacitors are used for initial ESD protection in the system and must be sized based on system level requirements.

The logic address pins are controlled by the micro controller to cycle between the eight switch inputs in the system. If the parts desired power-up state is disabled, then the enable pin should have a weak pull-up resistor and be controlled by the MCU through the GPIO.

### 9.2.3 Short To Battery Protection

When evaluating the safety and reliability of an automotive grade multiplexer, it is important to note their performance under various operating conditions. In the case of TMUX13xxA-Q1, we examine its response to various short-to-battery conditions to provide insight on system level design for automotive optimization. It is important to design around short-to-battery as failure to do so can result in operational issues. The following section shows a deep dive into two scenarios to demonstrate the behavior of the TMUX1308A-Q1 under short-to-battery conditions using a 5V supply voltage.

We begin with the following setup to explore our first scenario with channel S7 selected and channel S0 experiencing a short-to-battery condition.

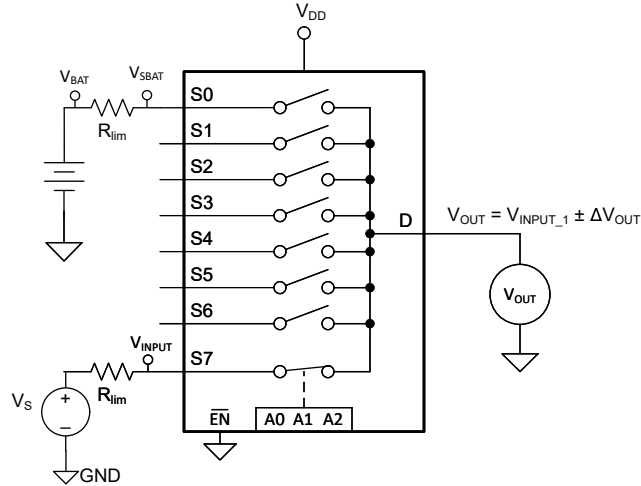

**Figure 9-2. Channel S7 Selected, Channel S0 Experiencing a Short-to-Battery Condition**

Table 9-2 indicates values of  $\Delta V_{OUT}$ ,  $V_{SBAT}$  and minimum  $R_{LIM}$  for various  $V_{BAT}$  cases when considering a maximum allotment of 25mA for  $I_S/I_D$ . Choosing too large of an  $R_{LIM}$  will negatively affect  $\Delta V_{OUT}$  as well as substantially limit current flow. Choosing too small of an  $R_{LIM}$  can damage the device.

Table 9-2.  $R_{LIM}$  Values for 25mA Through the Switch

$V_{BAT}$	$R_{LIM}$	$\Delta V_{OUT}$ (typ)	$V_{SBAT}$
12V	470	< 10 $\mu$ V	5.6V
19V	750	< 10 $\mu$ V	5.6V
24V	1K	< 10 $\mu$ V	5.6V
36V	1.5K	< 10 $\mu$ V	5.6V
48V	2K	< 10 $\mu$ V	5.6V
60V	2.4K	< 10 $\mu$ V	5.6V

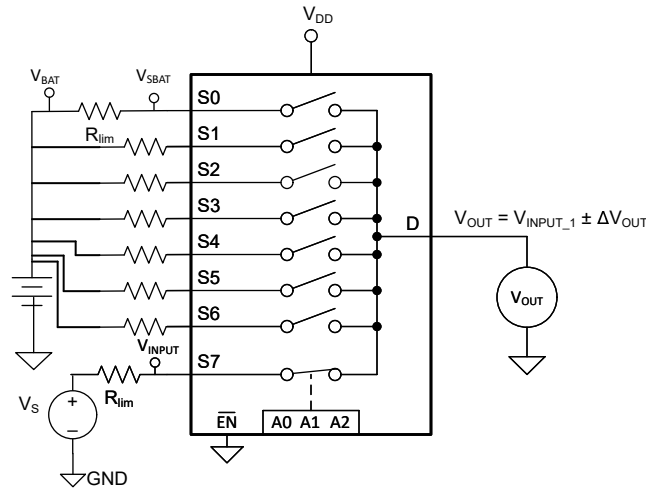

Figure 9-3. All Unselected Channels Experiencing a Short-to-Battery Condition

We then evaluate the scenario of seeing a short-to-battery condition on all unselected channels at the same time. The following table indicates values when considering a maximum allotment of 12.5mA for  $I_S/I_D$  (for more information, see Section 6.1). If you have the potential to see short-to-battery on all channels at the same time, then 12.5mA is the limiting factor. Here again choosing too large of an  $R_{LIM}$  will negatively affect  $\Delta V_{OUT}$  as well as substantially limit current flow.

**CAUTION**

To avoid damage to the device do not choose too small of an  $R_{LIM}$ .

Table 9-3.  $R_{LIM}$  Values for 12.5mA Through the Switch

$V_{BAT}$	$R_{LIM}$	$\Delta V_{OUT}$ (typ)	$V_{SBAT}$
12V	1K	< 10 $\mu$ V	5.6V
19V	1.5K	< 10 $\mu$ V	5.6V
24V	2K	< 10 $\mu$ V	5.6V
36V	3K	< 10 $\mu$ V	5.6V
48V	3.9K	< 10 $\mu$ V	5.6V
60V	4.7K	< 10 $\mu$ V	5.6V

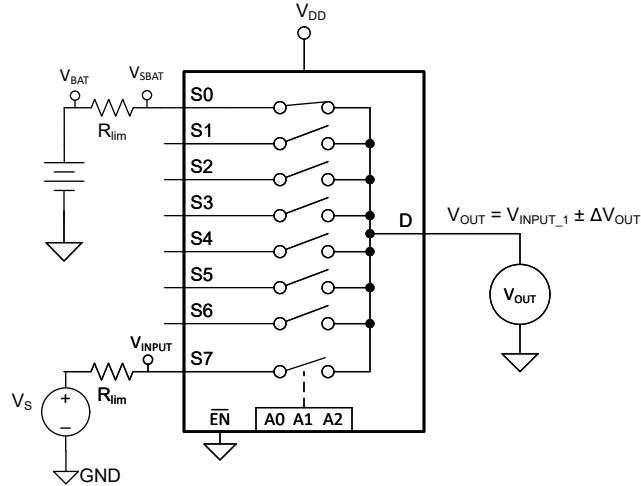
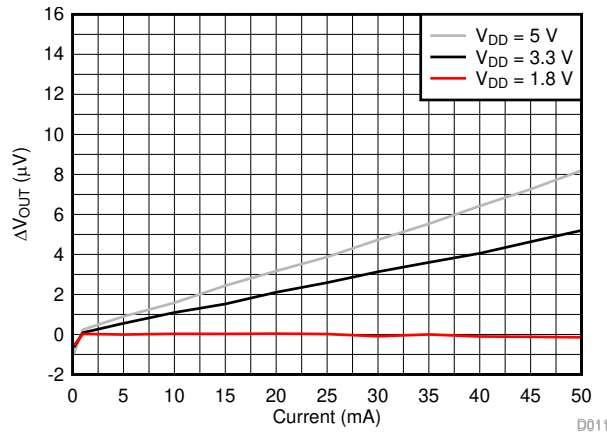

**Figure 9-4. Short-to-Battery Condition Only on a Single Selected Channel**

**CAUTION**  
 To avoid damage to the device do not choose too small of an  $R_{LIM}$ .

In conclusion, several short-to-battery case studies were observed using a 5V supply. Note that if using a lower supply voltage, the  $R_{LIM}$  values will change for optimal current flow. It is important to protect against short-to-battery conditions as a failure to do so can result in system level issues. Take care to design around these conditions and the electrical characteristics for proper device operation.

### 9.2.4 Application Curve



**Figure 9-5. Injection Current vs. Maximum Output Voltage Shift**

## 9.3 Power Supply Recommendations

The TMUX1308A-Q1 and TMUX1309A-Q1 devices operate across a wide supply range of 1.62V to 5.5V. Note: do not exceed the absolute maximum ratings because stresses beyond the listed ratings can cause permanent damage to the devices.

Power-supply bypassing improves noise margin and prevents switching noise propagation from the  $V_{DD}$  supply to other components. Good power-supply decoupling is important to achieve optimum performance. For improved supply noise immunity, use a supply decoupling capacitor ranging from 0.1 $\mu F$  to 10 $\mu F$  from  $V_{DD}$  to ground. Place the bypass capacitors as close to the power supply pins of the device as possible using low-impedance connections.

TI recommends using multi-layer ceramic chip capacitors (MLCCs) that offer low equivalent series resistance (ESR) and inductance (ESL) characteristics for power-supply decoupling purposes. For very sensitive systems, or for systems in harsh noise environments, avoiding the use of vias for connecting the capacitors to the device pins may offer superior noise immunity. The use of multiple vias in parallel lowers the overall inductance and is beneficial for connections to ground planes.

## 9.4 Layout

### 9.4.1 Layout Guidelines

When a PCB trace turns a corner at a 90° angle, a reflection can occur. A reflection occurs primarily because of the change of width of the trace. At the apex of the turn, the trace width increases to 1.414 times the width. This increase upsets the transmission-line characteristics, especially the distributed capacitance and self-inductance of the trace which results in the reflection. Not all PCB traces can be straight; therefore, some traces must turn corners. [Figure 9-6](#) shows progressively better techniques of rounding corners. Only the last example (BEST) maintains constant trace width and minimizes reflections.

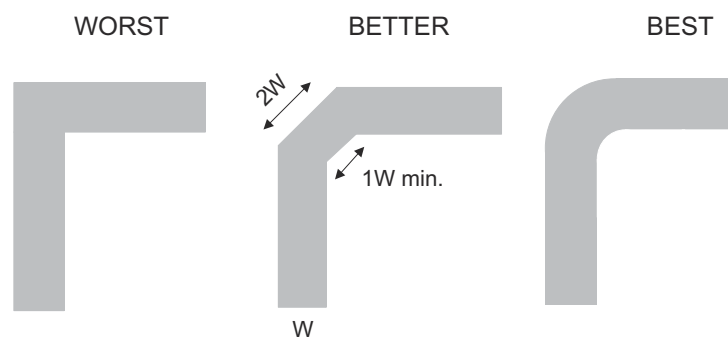

**Figure 9-6. Trace Example**

Route high-speed signals using a minimum of vias and corners which reduces signal reflections and impedance changes. When a via must be used, increase the clearance size around it to minimize its capacitance. Each via introduces discontinuities in the signal's transmission line and increases the chance of picking up interference from the other layers of the board. Be careful when designing test points, through-hole pins are not recommended at high frequencies.

[Figure 9-7](#) shows an example of a PCB layout with the TMUX1308A-Q1 and TMUX1309A-Q1. Some key considerations are as follows:

- Decouple the  $V_{DD}$  pin with a 0.1  $\mu\text{F}$  capacitor, placed as close to the pin as possible. Make sure that the capacitor voltage rating is sufficient for the  $V_{DD}$  supply.
- Keep the input lines as short as possible.
- Use a solid ground plane to help reduce electromagnetic interference (EMI) noise pickup.
- Do not run sensitive analog traces in parallel with digital traces. Avoid crossing digital and analog traces if possible, and only make perpendicular crossings when necessary.

### 9.4.2 Layout Example

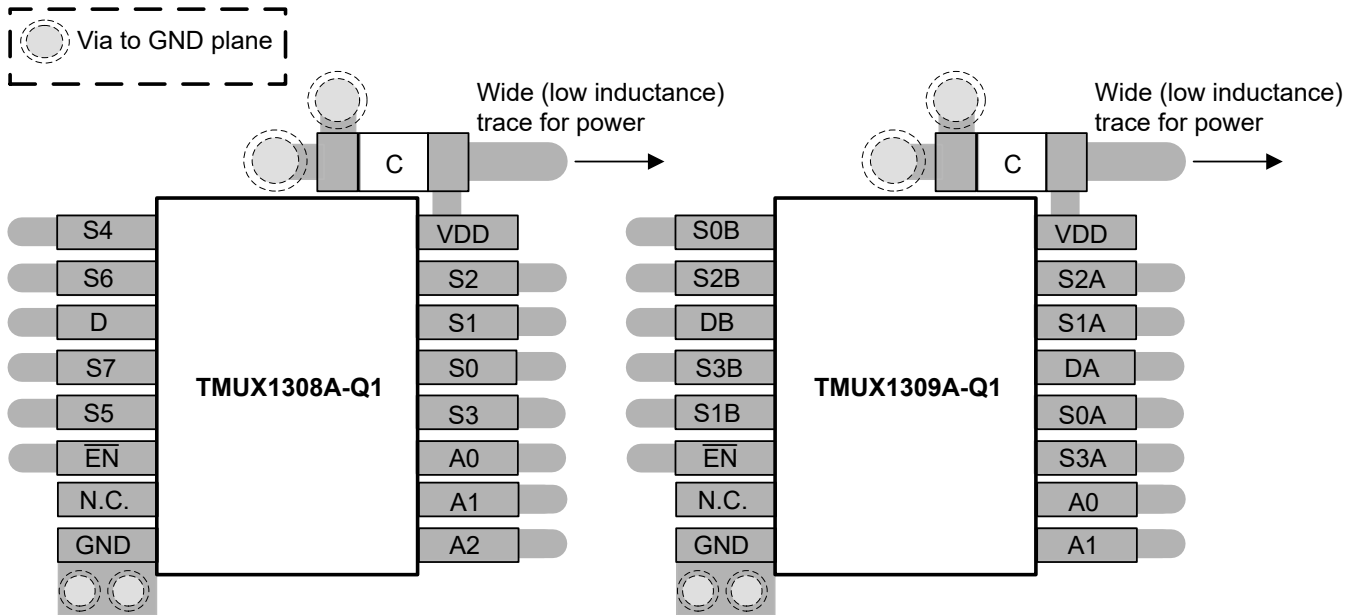

Figure 9-7. TMUX1308A-Q1 and TMUX1309A-Q1 Layout Example

## 10 Device and Documentation Support

### 10.1 Documentation Support

#### 10.1.1 Related Documentation

For related documentation, see the following:

- Texas Instruments, [Simplifying Design with 1.8V logic Muxes and Switches](#)
- Texas Instruments, [QFN/SON PCB Attachment](#)
- Texas Instruments, [Quad Flatpack No-Lead Logic Packages](#)

### 10.2 Receiving Notification of Documentation Updates

To receive notification of documentation updates, navigate to the device product folder on ti.com. In the upper right corner, click on *Alert me* to register and receive a weekly digest of any product information that has changed. For change details, review the revision history included in any revised document.

### 10.3 Support Resources

TI E2E™ support forums are an engineer's go-to source for fast, verified answers and design help — straight from the experts. Search existing answers or ask your own question to get the quick design help you need.

Linked content is provided "AS IS" by the respective contributors. They do not constitute TI specifications and do not necessarily reflect TI's views; see TI's [Terms of Use](#).

### 10.4 Trademarks

TI E2E™ is a trademark of Texas Instruments.

All trademarks are the property of their respective owners.

### 10.5 Electrostatic Discharge Caution



This integrated circuit can be damaged by ESD. Texas Instruments recommends that all integrated circuits be handled with appropriate precautions. Failure to observe proper handling and installation procedures can cause damage.

ESD damage can range from subtle performance degradation to complete device failure. Precision integrated circuits may be more susceptible to damage because very small parametric changes could cause the device not to meet its published specifications.

### 10.6 Glossary

[TI Glossary](#) This glossary lists and explains terms, acronyms, and definitions.

## 11 Revision History

NOTE: Page numbers for previous revisions may differ from page numbers in the current version.

Changes from Revision * (June 2024) to Revision A (June 2025)	Page
• Added BQB and DYY packages.....	1

DATE	REVISION	NOTES
June 2024	*	Initial Release

## 12 Mechanical, Packaging, and Orderable Information

The following pages include mechanical, packaging, and orderable information. This information is the most current data available for the designated devices. This data is subject to change without notice and revision of this document. For browser-based versions of this data sheet, refer to the left-hand navigation.

**PACKAGING INFORMATION**

Orderable part number	Status (1)	Material type (2)	Package   Pins	Package qty   Carrier	RoHS (3)	Lead finish/ Ball material (4)	MSL rating/ Peak reflow (5)	Op temp (°C)	Part marking (6)
<a href="#">TMUX1308AQPWRQ1</a>	Active	Production	TSSOP (PW)   16	3000   LARGE T&R	Yes	NIPDAU	Level-1-260C-UNLIM	-40 to 125	1308AQ
TMUX1308AQPWRQ1.A	Active	Production	null (null)	3000   LARGE T&R	-	NIPDAU	Level-1-260C-UNLIM	See TMUX1308AQPWRQ1	1308AQ
<a href="#">TMUX1309AQPWRQ1</a>	Active	Production	TSSOP (PW)   16	3000   LARGE T&R	Yes	NIPDAU	Level-1-260C-UNLIM	-40 to 125	1309AQ
TMUX1309AQPWRQ1.A	Active	Production	null (null)	3000   LARGE T&R	-	NIPDAU	Level-1-260C-UNLIM	See TMUX1309AQPWRQ1	1309AQ

(1) **Status:** For more details on status, see our [product life cycle](#).

(2) **Material type:** When designated, preproduction parts are prototypes/experimental devices, and are not yet approved or released for full production. Testing and final process, including without limitation quality assurance, reliability performance testing, and/or process qualification, may not yet be complete, and this item is subject to further changes or possible discontinuation. If available for ordering, purchases will be subject to an additional waiver at checkout, and are intended for early internal evaluation purposes only. These items are sold without warranties of any kind.

(3) **RoHS values:** Yes, No, RoHS Exempt. See the [TI RoHS Statement](#) for additional information and value definition.

(4) **Lead finish/Ball material:** Parts may have multiple material finish options. Finish options are separated by a vertical ruled line. Lead finish/Ball material values may wrap to two lines if the finish value exceeds the maximum column width.

(5) **MSL rating/Peak reflow:** The moisture sensitivity level ratings and peak solder (reflow) temperatures. In the event that a part has multiple moisture sensitivity ratings, only the lowest level per JEDEC standards is shown. Refer to the shipping label for the actual reflow temperature that will be used to mount the part to the printed circuit board.

(6) **Part marking:** There may be an additional marking, which relates to the logo, the lot trace code information, or the environmental category of the part.

Multiple part markings will be inside parentheses. Only one part marking contained in parentheses and separated by a "-" will appear on a part. If a line is indented then it is a continuation of the previous line and the two combined represent the entire part marking for that device.

**Important Information and Disclaimer:**The information provided on this page represents TI's knowledge and belief as of the date that it is provided. TI bases its knowledge and belief on information provided by third parties, and makes no representation or warranty as to the accuracy of such information. Efforts are underway to better integrate information from third parties. TI has taken and continues to take reasonable steps to provide representative and accurate information but may not have conducted destructive testing or chemical analysis on incoming materials and chemicals. TI and TI suppliers consider certain information to be proprietary, and thus CAS numbers and other limited information may not be available for release.

In no event shall TI's liability arising out of such information exceed the total purchase price of the TI part(s) at issue in this document sold by TI to Customer on an annual basis.

**OTHER QUALIFIED VERSIONS OF TMUX1308A-Q1, TMUX1309A-Q1 :**

- Catalog : [TMUX1308A](#), [TMUX1309A](#)

## NOTE: Qualified Version Definitions:

- Catalog - TI's standard catalog product

**TAPE AND REEL INFORMATION**

**QUADRANT ASSIGNMENTS FOR PIN 1 ORIENTATION IN TAPE**

\*All dimensions are nominal

Device	Package Type	Package Drawing	Pins	SPQ	Reel Diameter (mm)	Reel Width W1 (mm)	A0 (mm)	B0 (mm)	K0 (mm)	P1 (mm)	W (mm)	Pin1 Quadrant
TMUX1308AQPWRQ1	TSSOP	PW	16	3000	330.0	12.4	6.9	5.6	1.6	8.0	12.0	Q1
TMUX1309AQPWRQ1	TSSOP	PW	16	3000	330.0	12.4	6.9	5.6	1.6	8.0	12.0	Q1

**TAPE AND REEL BOX DIMENSIONS**

\*All dimensions are nominal

Device	Package Type	Package Drawing	Pins	SPQ	Length (mm)	Width (mm)	Height (mm)
TMUX1308AQPWRQ1	TSSOP	PW	16	3000	353.0	353.0	32.0
TMUX1309AQPWRQ1	TSSOP	PW	16	3000	353.0	353.0	32.0



4220204/A 02/2017

NOTES:

1. All linear dimensions are in millimeters. Any dimensions in parenthesis are for reference only. Dimensioning and tolerancing per ASME Y14.5M.
2. This drawing is subject to change without notice.
3. This dimension does not include mold flash, protrusions, or gate burrs. Mold flash, protrusions, or gate burrs shall not exceed 0.15 mm per side.
4. This dimension does not include interlead flash. Interlead flash shall not exceed 0.25 mm per side.
5. Reference JEDEC registration MO-153.

# EXAMPLE BOARD LAYOUT

PW0016A

TSSOP - 1.2 mm max height

SMALL OUTLINE PACKAGE



LAND PATTERN EXAMPLE  
EXPOSED METAL SHOWN  
SCALE: 10X



SOLDER MASK DETAILS

4220204/A 02/2017

NOTES: (continued)

- 6. Publication IPC-7351 may have alternate designs.
- 7. Solder mask tolerances between and around signal pads can vary based on board fabrication site.

# EXAMPLE STENCIL DESIGN

PW0016A

TSSOP - 1.2 mm max height

SMALL OUTLINE PACKAGE



SOLDER PASTE EXAMPLE  
BASED ON 0.125 mm THICK STENCIL  
SCALE: 10X

4220204/A 02/2017

NOTES: (continued)

8. Laser cutting apertures with trapezoidal walls and rounded corners may offer better paste release. IPC-7525 may have alternate design recommendations.
9. Board assembly site may have different recommendations for stencil design.

## IMPORTANT NOTICE AND DISCLAIMER

TI PROVIDES TECHNICAL AND RELIABILITY DATA (INCLUDING DATA SHEETS), DESIGN RESOURCES (INCLUDING REFERENCE DESIGNS), APPLICATION OR OTHER DESIGN ADVICE, WEB TOOLS, SAFETY INFORMATION, AND OTHER RESOURCES "AS IS" AND WITH ALL FAULTS, AND DISCLAIMS ALL WARRANTIES, EXPRESS AND IMPLIED, INCLUDING WITHOUT LIMITATION ANY IMPLIED WARRANTIES OF MERCHANTABILITY, FITNESS FOR A PARTICULAR PURPOSE OR NON-INFRINGEMENT OF THIRD PARTY INTELLECTUAL PROPERTY RIGHTS.

These resources are intended for skilled developers designing with TI products. You are solely responsible for (1) selecting the appropriate TI products for your application, (2) designing, validating and testing your application, and (3) ensuring your application meets applicable standards, and any other safety, security, regulatory or other requirements.

These resources are subject to change without notice. TI grants you permission to use these resources only for development of an application that uses the TI products described in the resource. Other reproduction and display of these resources is prohibited. No license is granted to any other TI intellectual property right or to any third party intellectual property right. TI disclaims responsibility for, and you will fully indemnify TI and its representatives against, any claims, damages, costs, losses, and liabilities arising out of your use of these resources.

TI's products are provided subject to [TI's Terms of Sale](#) or other applicable terms available either on [ti.com](https://www.ti.com) or provided in conjunction with such TI products. TI's provision of these resources does not expand or otherwise alter TI's applicable warranties or warranty disclaimers for TI products.

TI objects to and rejects any additional or different terms you may have proposed.

Mailing Address: Texas Instruments, Post Office Box 655303, Dallas, Texas 75265

Copyright © 2025, Texas Instruments Incorporated