

CY54FCT273T, CY74FCT273T 8-BIT REGISTERS

SCCS020A – MARCH 1995 – REVISED OCTOBER 2001

- Function, Pinout, and Drive Compatible With FCT and F Logic
- Reduced V_{OH} (Typically = 3.3 V) Versions of Equivalent FCT Functions
- Edge-Rate Control Circuitry for Significantly Improved Noise Characteristics
- I_{off} Supports Partial-Power-Down Mode Operation
- Matched Rise and Fall Times
- ESD Protection Exceeds JESD 22
 - 2000-V Human-Body Model (A114-A)
 - 200-V Machine Model (A115-A)
 - 1000-V Charged-Device Model (C101)
- Fully Compatible With TTL Input and Output Logic Levels
- CY54FCT273T
 - 32-mA Output Sink Current
 - 12-mA Output Source Current
- CY74FCT273T
 - 64-mA Output Sink Current
 - 32-mA Output Source Current

description

The 'FCT273T devices consist of eight edge-triggered D-type flip-flops with individual D inputs and Q outputs. The common buffered-clock (CP) and master-reset (\overline{MR}) inputs load and reset all flip-flops simultaneously. These devices are edge-triggered registers. The state of each D input (one setup time before the low-to-high clock transition) is transferred to the corresponding flip-flop's Q output. All outputs are forced low by a low logic level on the \overline{MR} input.

This device is fully specified for partial-power-down applications using I_{off} . The I_{off} circuitry disables the outputs, preventing damaging current backflow through the device when it is powered down.

CY54FCT273T . . . D PACKAGE
CY74FCT273T . . . Q OR SO PACKAGE
(TOP VIEW)

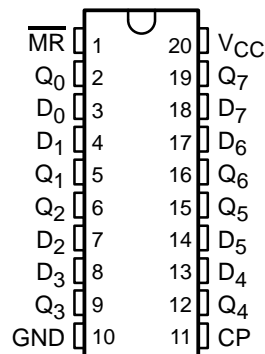

CY54FCT273T . . . L PACKAGE
(TOP VIEW)

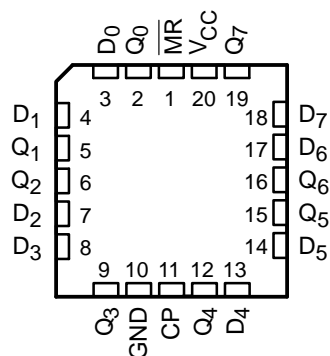

Please be aware that an important notice concerning availability, standard warranty, and use in critical applications of Texas Instruments semiconductor products and disclaimers thereto appears at the end of this data sheet.

PRODUCTION DATA information is current as of publication date. Products conform to specifications per the terms of Texas Instruments standard warranty. Production processing does not necessarily include testing of all parameters.



POST OFFICE BOX 655303 • DALLAS, TEXAS 75265

Copyright © 2001, Texas Instruments Incorporated

CY54FCT273T, CY74FCT273T 8-BIT REGISTERS

SCCS020A – MARCH 1995 – REVISED OCTOBER 2001

ORDERING INFORMATION

T _A	PACKAGE†		SPEED (ns)	ORDERABLE PART NUMBER	TOP-SIDE MARKING
-40°C to 85°C	QSOP – Q	Tape and reel	5.8	CY74FCT273CTQCT	FCT273C
	SOIC – SO	Tube	5.8	CY74FCT273CTSOC	FCT273C
		Tape and reel	5.8	CY74FCT273CTSOCT	
	QSOP – Q	Tape and reel	7.2	CY74FCT273ATQCT	FCT273A
		SOIC – SO	Tube	7.2	CY74FCT273ATSOC
	Tape and reel		7.2	CY74FCT273ATSOCT	
-55°C to 125°C	QSOP – Q	Tape and reel	13	CY74FCT273TQCT	FCT273
	SOIC – SO	Tube	13	CY74FCT273TSOC	FCT273
		Tape and reel	13	CY74FCT273TSOCT	
	LCC – L	Tube	8.3	CY54FCT273ATLMB	

† Package drawings, standard packing quantities, thermal data, symbolization, and PCB design guidelines are available at www.ti.com/sc/package.

FUNCTION TABLE

INPUTS			OUTPUT Q	OPERATING MODE
$\overline{\text{MR}}$	CP	D		
L	X	X	L	Reset (clear)
H	↑	h	H	Load '1'
H	↑	l	L	Load '0'

H = High logic level steady state, h = High logic level one setup time prior to low-to-high clock transition, L = Low logic level steady state, l = Low logic level one setup time prior to the low-to-high transition, X = Don't care, ↑ = Low-to-high clock transition

logic diagram (positive logic)

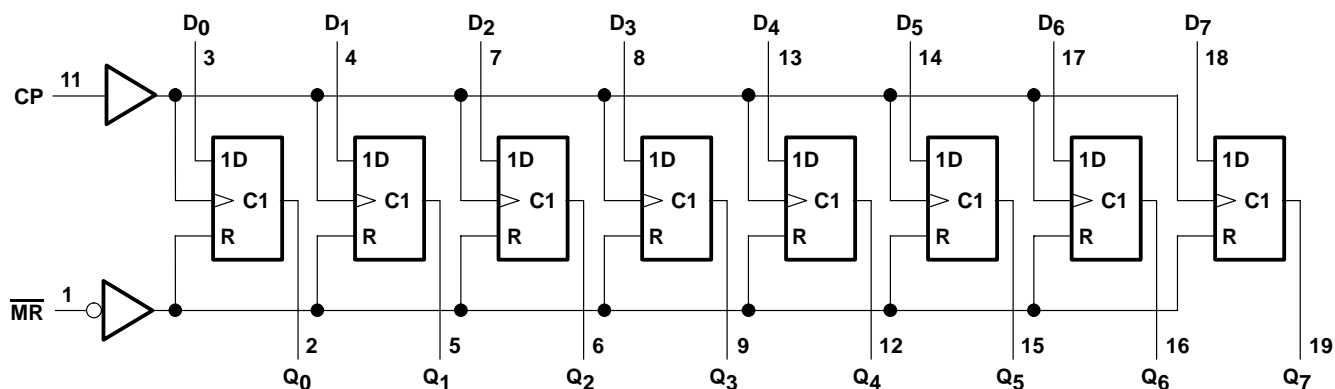

absolute maximum ratings over operating free-air temperature range (unless otherwise noted)†

Supply voltage range to ground potential	–0.5 V to 7 V
DC input voltage range	–0.5 V to 7 V
DC output voltage range	–0.5 V to 7 V
DC output current (maximum sink current/pin)	120 mA
Package thermal impedance, θ_{JA} (see Note 1): Q package	68°C/W
SO package	58°C/W
Ambient temperature range with power applied, T_A	–65°C to 135°C
Storage temperature range, T_{Stg}	–65°C to 150°C

† Stresses beyond those listed under “absolute maximum ratings” may cause permanent damage to the device. These are stress ratings only, and functional operation of the device at these or any other conditions beyond those indicated under “recommended operating conditions” is not implied. Exposure to absolute-maximum-rated conditions for extended periods may affect device reliability.

NOTE 1: The package thermal impedance is calculated in accordance with JESD 51-7.

recommended operating conditions (see Note 2)

	CY54FCT273T			CY74FCT273T			UNIT
	MIN	NOM	MAX	MIN	NOM	MAX	
V_{CC} Supply voltage	4.5	5	5.5	4.75	5	5.25	V
V_{IH} High-level input voltage	2			2			V
V_{IL} Low-level input voltage			0.8			0.8	V
I_{OH} High-level output current			–12			–32	mA
I_{OL} Low-level output current			32			64	mA
T_A Operating free-air temperature	–55		125	–40		85	°C

NOTE 2: All unused inputs of the device must be held at V_{CC} or GND to ensure proper device operation.

CY54FCT273T, CY74FCT273T

8-BIT REGISTERS

SCCS020A – MARCH 1995 – REVISED OCTOBER 2001

electrical characteristics over recommended operating free-air temperature range (unless otherwise noted)

PARAMETER	TEST CONDITIONS	CY54FCT273T			CY74FCT273T			UNIT
		MIN	TYP†	MAX	MIN	TYP†	MAX	
V _{IK}	V _{CC} = 4.5 V, I _{IN} = -18 mA	-0.7	-1.2					V
	V _{CC} = 4.75 V, I _{IN} = -18 mA				-0.7	-1.2		
V _{OH}	V _{CC} = 4.5 V, I _{OH} = -12 mA	2.4	3.3					V
	V _{CC} = 4.75 V	I _{OH} = -32 mA			2			
		I _{OH} = -15 mA			2.4	3.3		
V _{OL}	V _{CC} = 4.5 V, I _{OL} = 32 mA	0.3	0.55					V
	V _{CC} = 4.75 V, I _{OL} = 64 mA				0.3	0.55		
V _{hys}	All inputs	0.2			0.2			V
I _I	V _{CC} = 5.5 V, V _{IN} = V _{CC}			5				μA
	V _{CC} = 5.25 V, V _{IN} = V _{CC}					5		
I _{IH}	V _{CC} = 5.5 V, V _{IN} = 2.7 V			±1				μA
	V _{CC} = 5.25 V, V _{IN} = 2.7 V					±1		
I _{IL}	V _{CC} = 5.5 V, V _{IN} = 0.5 V			±1				μA
	V _{CC} = 5.25 V, V _{IN} = 0.5 V					±1		
I _{off}	V _{CC} = 0 V, V _{OUT} = 4.5 V			±1			±1	μA
I _{OS} ‡	V _{CC} = 5.5 V, V _{OUT} = 0 V	-60	-120	-225				mA
	V _{CC} = 5.25 V, V _{OUT} = 0 V				-60	-120	-225	
I _{CC}	V _{CC} = 5.5 V, V _{IN} ≤ 0.2 V, V _{IN} ≥ V _{CC} - 0.2 V	0.1	0.2					mA
	V _{CC} = 5.25 V, V _{IN} ≤ 0.2 V, V _{IN} ≥ V _{CC} - 0.2 V				0.1	0.2		
ΔI _{CC}	V _{CC} = 5.5 V, V _{IN} = 3.4 V§, f ₁ = 0, Outputs open	0.5	2					mA
	V _{CC} = 5.25 V, V _{IN} = 3.4 V§, f ₁ = 0, Outputs open				0.5	2		

† Typical values are at V_{CC} = 5 V, T_A = 25°C.

‡ Not more than one output should be shorted at a time. Duration of short should not exceed one second. The use of high-speed test apparatus and/or sample-and-hold techniques are preferable to minimize internal chip heating and more accurately reflect operational values. Otherwise, prolonged shorting of a high output can raise the chip temperature well above normal and cause invalid readings in other parametric tests. In any sequence of parameter tests, I_{OS} tests should be performed last.

§ Per TTL-driven input (V_{IN} = 3.4 V); all other inputs at V_{CC} or GND



electrical characteristics over recommended operating free-air temperature range (unless otherwise noted) (continued)

PARAMETER	TEST CONDITIONS		CY54FCT273T		CY74FCT273T		UNIT	
			MIN	TYP†	MAX	MIN		TYP†
I_{CCD}^{\ddagger}	$V_{CC} = 5.5$ V, Outputs open, One bit switching at 50% duty cycle, $\overline{MR} = V_{CC}$, $V_{IN} \leq 0.2$ V or $V_{IN} \geq V_{CC} - 0.2$ V		0.06	0.12			mA/ MHz	
	$V_{CC} = 5.25$ V, Outputs open, One bit switching at 50% duty cycle, $\overline{MR} = V_{CC}$, $V_{IN} \leq 0.2$ V or $V_{IN} \geq V_{CC} - 0.2$ V				0.06	0.12		
$I_C^{\#}$	$V_{CC} = 5.5$ V, $f_0 = 10$ MHz, Outputs open, $MR = V_{CC}$	One bit switching at $f_1 = 2.5$ MHz at 50% duty cycle	$V_{IN} \leq 0.2$ V or $V_{IN} \geq V_{CC} - 0.2$ V	0.7	1.4		mA	
			$V_{IN} = 3.4$ V or GND	1.2	3.4			
		Eight bits switching at $f_1 = 2.5$ MHz at 50% duty cycle	$V_{IN} \leq 0.2$ V or $V_{IN} \geq V_{CC} - 0.2$ V	1.6	3.2 \parallel			
			$V_{IN} = 3.4$ V or GND	3.9	12.2 \parallel			
	$V_{CC} = 5.25$ V, $f_0 = 10$ MHz, Outputs open, $MR = V_{CC}$	One bit switching at $f_1 = 5$ MHz at 50% duty cycle	$V_{IN} \leq 0.2$ V or $V_{IN} \geq V_{CC} - 0.2$ V			0.7		1.4
			$V_{IN} = 3.4$ V or GND			1.2		3.4
		Eight bits switching at $f_1 = 5$ MHz at 50% duty cycle	$V_{IN} \leq 0.2$ V or $V_{IN} \geq V_{CC} - 0.2$ V			1.6		3.2 \parallel
			$V_{IN} = 3.4$ V or GND			3.9		12.2 \parallel
C_i			5	10	5	10	pF	
C_o			9	12	9	12	pF	

† Typical values are at $V_{CC} = 5$ V, $T_A = 25^\circ\text{C}$.

\ddagger This parameter is derived for use in total power-supply calculations.

$$\# I_C = I_{CC} + \Delta I_{CC} \times D_H \times N_T + I_{CCD} (f_0/2 + f_1 \times N_1)$$

Where:

I_C = Total supply current

I_{CC} = Power-supply current with CMOS input levels

ΔI_{CC} = Power-supply current for a TTL high input ($V_{IN} = 3.4$ V)

D_H = Duty cycle for TTL inputs high

N_T = Number of TTL inputs at D_H

I_{CCD} = Dynamic current caused by an input transition pair (HLH or LHL)

f_0 = Clock frequency for registered devices, otherwise zero

f_1 = Input signal frequency

N_1 = Number of inputs changing at f_1

All currents are in milliamperes and all frequencies are in megahertz.

\parallel Values for these conditions are examples of the I_{CC} formula.

CY54FCT273T, CY74FCT273T 8-BIT REGISTERS

SCCS020A – MARCH 1995 – REVISED OCTOBER 2001

timing requirements over recommended operating free-air temperature range (unless otherwise noted) (see Figure 1)

			CY74FCT273T		CY54FCT273AT		CY74FCT273AT		CY74FCT273CT		UNIT
			MIN	MAX	MIN	MAX	MIN	MAX	MIN	MAX	
t _w	Pulse duration, high or low	CP	6		6		6		6		ns
		$\overline{\text{MR}}$	6		6		6		6		
t _{su}	Setup time, high or low	D before CP↑	2		2		2		2		ns
t _h	Hold time, high or low	D after CP↑	1.5		1.5		1.5		1.5		ns
t _{rec}	Recovery time	$\overline{\text{MR}}$ after CP↑	2		2.5		2		2		ns

switching characteristics over operating free-air temperature range (see Figure 1)

PARAMETER	FROM (INPUT)	TO (OUTPUT)	CY74FCT273T		CY54FCT273AT		CY74FCT273AT		CY74FCT273CT		UNIT
			MIN	MAX	MIN	MAX	MIN	MAX	MIN	MAX	
t _{PLH}	CP	Q	2	13	2	8.3	2	7.2	2	5.8	ns
t _{PHL}			2	13	2	8.3	2	7.2	2	5.8	
t _{PLH}	$\overline{\text{MR}}$	Q	2	13	2	8.3	2	7.2	2	6.1	ns
t _{PHL}			2	13	2	8.3	2	7.2	2	6.1	



PARAMETER MEASUREMENT INFORMATION

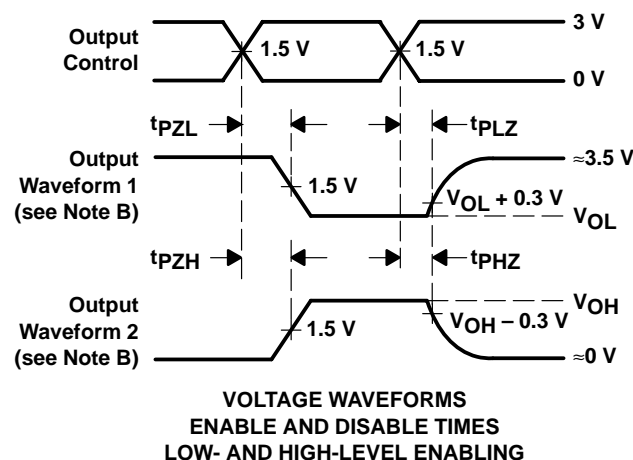
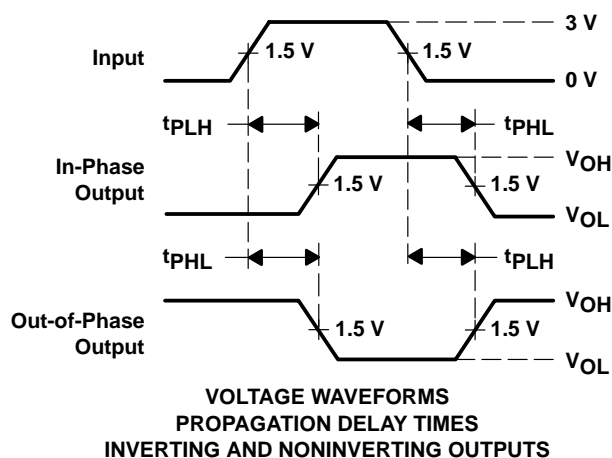
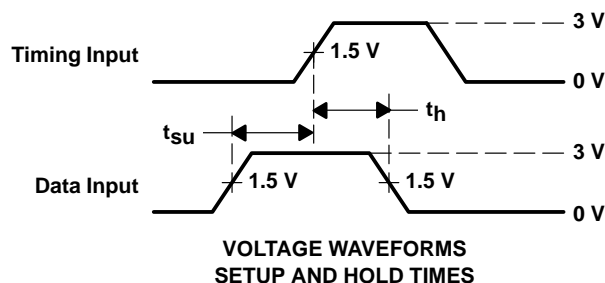
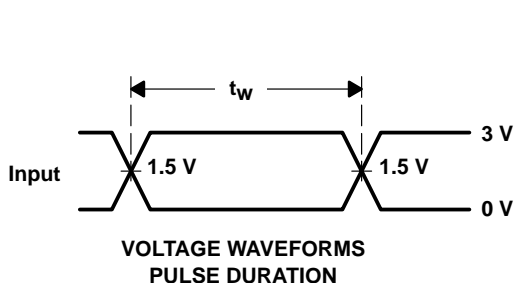
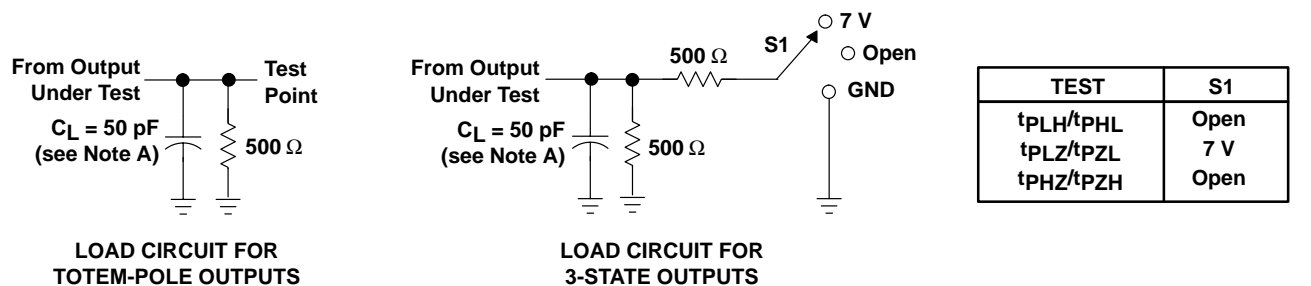

- NOTES: A. C_L includes probe and jig capacitance.
 B. Waveform 1 is for an output with internal conditions such that the output is low except when disabled by the output control. Waveform 2 is for an output with internal conditions such that the output is high except when disabled by the output control.
 C. The outputs are measured one at a time with one input transition per measurement.

Figure 1. Load Circuit and Voltage Waveforms

PACKAGING INFORMATION

Orderable part number	Status (1)	Material type (2)	Package Pins	Package qty Carrier	RoHS (3)	Lead finish/ Ball material (4)	MSL rating/ Peak reflow (5)	Op temp (°C)	Part marking (6)
5962-9221503M2A	Active	Production	LCCC (FK) 20	55 TUBE	No	SNPB	N/A for Pkg Type	-55 to 125	5962-9221503M2A CY54FCT 273ATLMB
5962-9221503MRA	Active	Production	CDIP (J) 20	20 TUBE	No	SNPB	N/A for Pkg Type	-55 to 125	5962-9221503MRA
CY54FCT273ATLMB	Active	Production	LCCC (FK) 20	55 TUBE	No	SNPB	N/A for Pkg Type	-55 to 125	5962-9221503M2A CY54FCT 273ATLMB
CY74FCT273ATQCT	Active	Production	SSOP (DBQ) 20	2500 LARGE T&R	Yes	NIPDAU	Level-2-260C-1 YEAR	-40 to 85	FCT273A
CY74FCT273ATQCT.B	Active	Production	SSOP (DBQ) 20	2500 LARGE T&R	Yes	NIPDAU	Level-2-260C-1 YEAR	-40 to 85	FCT273A
CY74FCT273ATQCTG4	Active	Production	SSOP (DBQ) 20	2500 LARGE T&R	Yes	NIPDAU	Level-2-260C-1 YEAR	-40 to 85	FCT273A
CY74FCT273ATQCTG4.B	Active	Production	SSOP (DBQ) 20	2500 LARGE T&R	Yes	NIPDAU	Level-2-260C-1 YEAR	-40 to 85	FCT273A
CY74FCT273ATSOC	Active	Production	SOIC (DW) 20	25 TUBE	Yes	NIPDAU	Level-1-260C-UNLIM	-40 to 85	FCT273A
CY74FCT273ATSOC.B	Active	Production	SOIC (DW) 20	25 TUBE	Yes	NIPDAU	Level-1-260C-UNLIM	-40 to 85	FCT273A
CY74FCT273ATSOCT	Active	Production	SOIC (DW) 20	2000 LARGE T&R	Yes	NIPDAU	Level-1-260C-UNLIM	-40 to 85	FCT273A
CY74FCT273ATSOCT.B	Active	Production	SOIC (DW) 20	2000 LARGE T&R	Yes	NIPDAU	Level-1-260C-UNLIM	-40 to 85	FCT273A
CY74FCT273CTQCT	Active	Production	SSOP (DBQ) 20	2500 LARGE T&R	Yes	NIPDAU	Level-2-260C-1 YEAR	-40 to 85	FCT273C
CY74FCT273CTQCT.B	Active	Production	SSOP (DBQ) 20	2500 LARGE T&R	Yes	NIPDAU	Level-2-260C-1 YEAR	-40 to 85	FCT273C
CY74FCT273CTSOC	Active	Production	SOIC (DW) 20	25 TUBE	Yes	NIPDAU	Level-1-260C-UNLIM	-40 to 85	FCT273C
CY74FCT273CTSOC.B	Active	Production	SOIC (DW) 20	25 TUBE	Yes	NIPDAU	Level-1-260C-UNLIM	-40 to 85	FCT273C
CY74FCT273TQCT	Active	Production	SSOP (DBQ) 20	2500 LARGE T&R	Yes	NIPDAU	Level-2-260C-1 YEAR	-40 to 85	FCT273
CY74FCT273TQCT.B	Active	Production	SSOP (DBQ) 20	2500 LARGE T&R	Yes	NIPDAU	Level-2-260C-1 YEAR	-40 to 85	FCT273
CY74FCT273TSOC	Active	Production	SOIC (DW) 20	25 TUBE	Yes	NIPDAU	Level-1-260C-UNLIM	-40 to 85	FCT273
CY74FCT273TSOC.B	Active	Production	SOIC (DW) 20	25 TUBE	Yes	NIPDAU	Level-1-260C-UNLIM	-40 to 85	FCT273
CY74FCT273TSOCT	Active	Production	SOIC (DW) 20	2000 LARGE T&R	Yes	NIPDAU	Level-1-260C-UNLIM	-40 to 85	FCT273
CY74FCT273TSOCT.B	Active	Production	SOIC (DW) 20	2000 LARGE T&R	Yes	NIPDAU	Level-1-260C-UNLIM	-40 to 85	FCT273

(1) **Status:** For more details on status, see our [product life cycle](#).

- (2) **Material type:** When designated, preproduction parts are prototypes/experimental devices, and are not yet approved or released for full production. Testing and final process, including without limitation quality assurance, reliability performance testing, and/or process qualification, may not yet be complete, and this item is subject to further changes or possible discontinuation. If available for ordering, purchases will be subject to an additional waiver at checkout, and are intended for early internal evaluation purposes only. These items are sold without warranties of any kind.
- (3) **RoHS values:** Yes, No, RoHS Exempt. See the [TI RoHS Statement](#) for additional information and value definition.
- (4) **Lead finish/Ball material:** Parts may have multiple material finish options. Finish options are separated by a vertical ruled line. Lead finish/Ball material values may wrap to two lines if the finish value exceeds the maximum column width.
- (5) **MSL rating/Peak reflow:** The moisture sensitivity level ratings and peak solder (reflow) temperatures. In the event that a part has multiple moisture sensitivity ratings, only the lowest level per JEDEC standards is shown. Refer to the shipping label for the actual reflow temperature that will be used to mount the part to the printed circuit board.
- (6) **Part marking:** There may be an additional marking, which relates to the logo, the lot trace code information, or the environmental category of the part.

Multiple part markings will be inside parentheses. Only one part marking contained in parentheses and separated by a "~" will appear on a part. If a line is indented then it is a continuation of the previous line and the two combined represent the entire part marking for that device.

Important Information and Disclaimer: The information provided on this page represents TI's knowledge and belief as of the date that it is provided. TI bases its knowledge and belief on information provided by third parties, and makes no representation or warranty as to the accuracy of such information. Efforts are underway to better integrate information from third parties. TI has taken and continues to take reasonable steps to provide representative and accurate information but may not have conducted destructive testing or chemical analysis on incoming materials and chemicals. TI and TI suppliers consider certain information to be proprietary, and thus CAS numbers and other limited information may not be available for release.

In no event shall TI's liability arising out of such information exceed the total purchase price of the TI part(s) at issue in this document sold by TI to Customer on an annual basis.

TAPE AND REEL INFORMATION

QUADRANT ASSIGNMENTS FOR PIN 1 ORIENTATION IN TAPE

*All dimensions are nominal

Device	Package Type	Package Drawing	Pins	SPQ	Reel Diameter (mm)	Reel Width W1 (mm)	A0 (mm)	B0 (mm)	K0 (mm)	P1 (mm)	W (mm)	Pin1 Quadrant
CY74FCT273ATQCT	SSOP	DBQ	20	2500	330.0	16.4	6.5	9.0	2.1	8.0	16.0	Q1
CY74FCT273ATQCTG4	SSOP	DBQ	20	2500	330.0	16.4	6.5	9.0	2.1	8.0	16.0	Q1
CY74FCT273ATSOCT	SOIC	DW	20	2000	330.0	24.4	10.8	13.3	2.7	12.0	24.0	Q1
CY74FCT273CTQCT	SSOP	DBQ	20	2500	330.0	16.4	6.5	9.0	2.1	8.0	16.0	Q1
CY74FCT273TQCT	SSOP	DBQ	20	2500	330.0	16.4	6.5	9.0	2.1	8.0	16.0	Q1
CY74FCT273TSOCT	SOIC	DW	20	2000	330.0	24.4	10.8	13.3	2.7	12.0	24.0	Q1

TAPE AND REEL BOX DIMENSIONS

*All dimensions are nominal

Device	Package Type	Package Drawing	Pins	SPQ	Length (mm)	Width (mm)	Height (mm)
CY74FCT273ATQCT	SSOP	DBQ	20	2500	356.0	356.0	35.0
CY74FCT273ATQCTG4	SSOP	DBQ	20	2500	356.0	356.0	35.0
CY74FCT273ATSOCT	SOIC	DW	20	2000	367.0	367.0	45.0
CY74FCT273CTQCT	SSOP	DBQ	20	2500	356.0	356.0	35.0
CY74FCT273TQCT	SSOP	DBQ	20	2500	356.0	356.0	35.0
CY74FCT273TSOCT	SOIC	DW	20	2000	367.0	367.0	45.0

TUBE

*All dimensions are nominal

Device	Package Name	Package Type	Pins	SPQ	L (mm)	W (mm)	T (μm)	B (mm)
5962-9221503M2A	FK	LCCC	20	55	506.98	12.06	2030	NA
CY54FCT273ATLMB	FK	LCCC	20	55	506.98	12.06	2030	NA
CY74FCT273ATSOC	DW	SOIC	20	25	507	12.83	5080	6.6
CY74FCT273ATSOC.B	DW	SOIC	20	25	507	12.83	5080	6.6
CY74FCT273CTSOC	DW	SOIC	20	25	507	12.83	5080	6.6
CY74FCT273CTSOC.B	DW	SOIC	20	25	507	12.83	5080	6.6
CY74FCT273TSOC	DW	SOIC	20	25	507	12.83	5080	6.6
CY74FCT273TSOC.B	DW	SOIC	20	25	507	12.83	5080	6.6

IMPORTANT NOTICE AND DISCLAIMER

TI PROVIDES TECHNICAL AND RELIABILITY DATA (INCLUDING DATA SHEETS), DESIGN RESOURCES (INCLUDING REFERENCE DESIGNS), APPLICATION OR OTHER DESIGN ADVICE, WEB TOOLS, SAFETY INFORMATION, AND OTHER RESOURCES "AS IS" AND WITH ALL FAULTS, AND DISCLAIMS ALL WARRANTIES, EXPRESS AND IMPLIED, INCLUDING WITHOUT LIMITATION ANY IMPLIED WARRANTIES OF MERCHANTABILITY, FITNESS FOR A PARTICULAR PURPOSE OR NON-INFRINGEMENT OF THIRD PARTY INTELLECTUAL PROPERTY RIGHTS.

These resources are intended for skilled developers designing with TI products. You are solely responsible for (1) selecting the appropriate TI products for your application, (2) designing, validating and testing your application, and (3) ensuring your application meets applicable standards, and any other safety, security, regulatory or other requirements.

These resources are subject to change without notice. TI grants you permission to use these resources only for development of an application that uses the TI products described in the resource. Other reproduction and display of these resources is prohibited. No license is granted to any other TI intellectual property right or to any third party intellectual property right. TI disclaims responsibility for, and you will fully indemnify TI and its representatives against, any claims, damages, costs, losses, and liabilities arising out of your use of these resources.

TI's products are provided subject to [TI's Terms of Sale](#) or other applicable terms available either on [ti.com](https://www.ti.com) or provided in conjunction with such TI products. TI's provision of these resources does not expand or otherwise alter TI's applicable warranties or warranty disclaimers for TI products.

TI objects to and rejects any additional or different terms you may have proposed.

Mailing Address: Texas Instruments, Post Office Box 655303, Dallas, Texas 75265

Copyright © 2025, Texas Instruments Incorporated