

CSD95372BQ5M Synchronous Buck NexFET™ Smart Power Stage

1 Features

- 60 A Continuous Operating Current Capability
- 93.4% System Efficiency at 30 A
- Low Power Loss of 2.8 W at 30 A
- High-Frequency Operation (up to 1.25 MHz)
- Diode Emulation Mode With FCCM
- Temperature Compensated Bi-Directional Current Sense
- Analog Temperature Output (600 mV at 0°C)
- Fault Monitoring
 - High-Side Short, Overcurrent, and Overtemperature Protection
- 3.3 and 5-V PWM Signal Compatible
- Tri-State PWM Input
- Integrated Bootstrap Diode
- Optimized Deadtime for Shoot Through Protection
- High-Density SON 5 × 6 mm Footprint
- Ultra-Low Inductance Package
- System Optimized PCB Footprint
- RoHS Compliant – Lead-Free Terminal Plating
- Halogen Free

2 Applications

- Multiphase Synchronous Buck Converters
 - High-Frequency Applications
 - High-Current, Low-Duty Cycle Applications
- POL DC-DC Converters
- Memory and Graphic Cards
- Desktop and Server VR11.x / VR12.x V-Core and Memory Synchronous Converters

3 Description

The CSD95372BQ5M NexFET™ smart power stage is a highly optimized design for use in a high-power, high-density Synchronous Buck converter. This product integrates the Driver IC and Power MOSFETs to complete the power stage switching function. This combination produces high-current, high-efficiency, and high-speed switching capability in a small 5-mm × 6-mm outline package. It also integrates the accurate current sensing system and temperature sensing functionality to simplify system design and improve accuracy. In addition, the PCB footprint has been optimized to help reduce design time and simplify the completion of the overall system design.

Device Information⁽¹⁾

Device	Media	Qty	Package	Ship
CSD95372BQ5M	13-Inch Reel	2500	SON 5 mm × 6 mm Package	Tape and Reel
CSD95372BQ5MT	7-Inch Reel	250		

(1) For all available packages, see the orderable addendum at the end of the data sheet.

Application Diagram

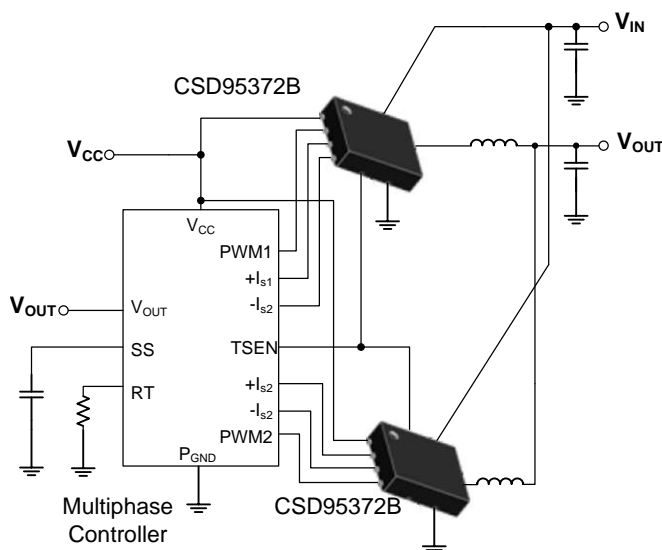

Typical Power Stage Efficiency and Power Loss

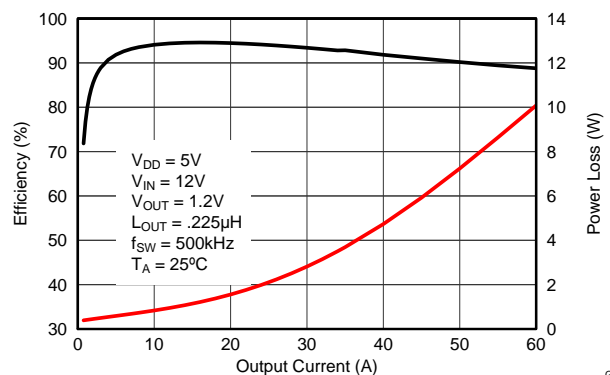

G001



Table of Contents

1 Features	1	7 Application Schematic	5
2 Applications	1	8 Device and Documentation Support	6
3 Description	1	8.1 Trademarks	6
4 Revision History	2	8.2 Electrostatic Discharge Caution	6
5 Pin Configuration and Functions	3	8.3 Glossary	6
6 Specifications	4	9 Mechanical, Packaging, and Orderable Information	7
6.1 Absolute Maximum Ratings	4	9.1 Mechanical Drawing	7
6.2 Handling Ratings	4	9.2 Recommended PCB Land Pattern	8
6.3 Recommended Operating Conditions	4	9.3 Recommended Stencil Opening	8
6.4 Thermal Information	4		

4 Revision History

Changes from Revision A (June 2014) to Revision B

Page

- Changed application schematic to show I_{OUT} (not I_{MON}) for each CSD95372B device. **5**

Changes from Original (March 2014) to Revision A

Page

- Removed "input voltage up to 14.5 V" and "DualCool™ package" bullets from the Features **1**
- Fixed TAO/FAULT pin function to state that TAO will be pulled up to 3.3 V in the event of thermal shutdown **3**
- Added minimum ESD Ratings **4**
- Increased maximum input voltage to 16 V **4**
- Added table note for max input voltage **4**

5 Pin Configuration and Functions

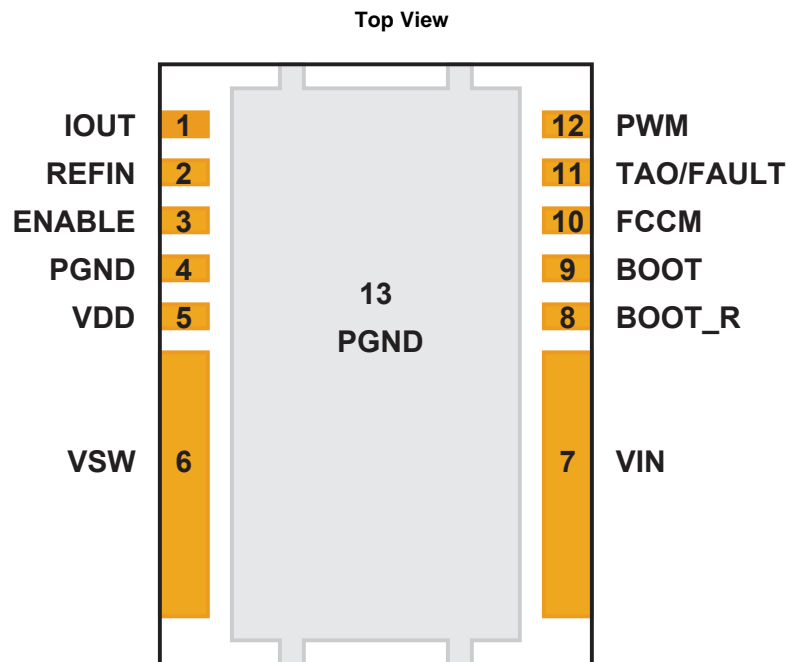

Pin Functions

PIN		DESCRIPTION
NAME	NUMBER	
BOOT	9	Bootstrap capacitor connection. Connect a minimum of 0.1 μF 16 V X7R ceramic capacitor from BOOT to BOOT_R pins. The bootstrap capacitor provides the charge to turn on the control FET. The bootstrap diode is integrated.
BOOT_R	8	Return path for HS gate driver, connected to V_{SW} internally.
ENABLE	3	Enables device operation. If ENABLE = logic HIGH, turns on device. If ENABLE = logic LOW, the device is turned off and both MOSFET gates are actively pulled low. An internal 100-k Ω pulldown resistor will pull the ENABLE pin LOW if left floating.
FCCM	10	This pin enables the Diode Emulation function. When this pin is held LOW, Diode Emulation Mode is enabled for sync FET. When FCCM is HIGH, the device is operated in Forced Continuous Conduction Mode. An internal 5 μA current source will pull the FCCM pin to 3.3 V if left floating.
IOUT	1	Output of current sensing amplifier. $V(\text{IOUT}) - V(\text{REFIN})$ is proportional to the phase current.
P_{GND}	4	Power ground, connected directly to pin 13.
P_{GND}	13	Power ground
PWM	12	Pulse width modulated 3-state input from external controller. Logic LOW sets control FET gate low and sync FET gate high. Logic HIGH sets control FET gate high and sync FET gate low. Open or High Z sets both MOSFET gates low if greater than the 3-state shutdown hold-off time ($t_{3\text{HT}}$).
REFIN	2	External reference voltage input for current sensing amplifier
TAO/FAULT	11	Temperature Analog Output. Reports a voltage proportional to the die temperature. An ORing diode is integrated in the IC. When used in multiphase application, a single wire can be used to connect the TAO pins of all the IC's. Only the highest temperature will be reported. TAO will be pulled up to 3.3 V if thermal shutdown occurs. TAO should be bypassed to P_{GND} with a 1-nF 16-V X7R ceramic capacitor.
V_{DD}	5	Supply voltage to gate driver and internal circuitry
V_{IN}	7	Input voltage pin. Connect input capacitors close to this pin.
V_{SW}	6	Phase node connecting the HS MOSFET source and LS MOSFET drain – pin connection to the output inductor.

6 Specifications

6.1 Absolute Maximum Ratings

 $T_A = 25^\circ\text{C}$ (unless otherwise noted)⁽¹⁾

	MIN	MAX	UNIT
V_{IN} to P_{GND}	-0.3	25	V
V_{IN} to V_{SW}	-0.3	25	V
V_{IN} to V_{SW} (10 ns)	-7	27	V
V_{SW} to P_{GND}	-0.3	20	V
V_{SW} to P_{GND} (10 ns)	-7	23	V
V_{DD} to P_{GND}	-0.3	7	V
ENABLE, PWM, FCCM, TAO, IOOUT, REFIN to P_{GND}	-0.3	$V_{DD} + 0.3\text{ V}$	V
BOOT to BOOT_R ⁽²⁾	-0.3	$V_{DD} + 0.3\text{ V}$	V
P_D , power dissipation		12	W
T_J , operating junction	-55	150	$^\circ\text{C}$

- (1) Stresses beyond those listed under *absolute maximum ratings* may cause permanent damage to the device. These are stress ratings only, and functional operation of the device at these or any other conditions beyond those indicated is not implied. Exposure to absolute-maximum-rated conditions for extended periods may affect device reliability.
- (2) Should not exceed 7 V

6.2 Handling Ratings

	MIN	MAX	UNIT	
T_{stg}	Storage temperature range		$^\circ\text{C}$	
$V_{(ESD)}$	Electrostatic discharge			
	Human body model (HBM)	-2000	2000	V
	Charged device model (CDM)	-500	500	V

6.3 Recommended Operating Conditions

 $T_A = 25^\circ$ (unless otherwise noted)

	MIN	MAX	UNIT		
V_{DD}	Gate drive voltage	4.5	5.5	V	
V_{IN}	Input supply voltage ⁽¹⁾		16	V	
V_{OUT}	Output voltage		5.5	V	
I_{OUT}	Continuous output current	$V_{IN} = 12\text{ V}$, $V_{DD} = 5\text{ V}$, $V_{OUT} = 1.2\text{ V}$, $f_{SW} = 500\text{ kHz}$, $L_{OUT} = 0.225\text{ }\mu\text{H}$ ⁽²⁾	60		
I_{OUT-PK}	Peak output current ⁽³⁾		90	A	
f_{SW}	Switching frequency	$C_{BST} = 0.1\text{ }\mu\text{F}$ (min)	1250	kHz	
	On-time duty cycle	$f_{SW} = 1\text{ MHz}$	85	%	
	Minimum PWM on-time		40	ns	
	Operating temperature		-40	125	$^\circ\text{C}$

- (1) Operating at high V_{IN} can create excessive AC voltage overshoots on the switch node (V_{SW}) during MOSFET switching transients. For reliable operation, the switch node (V_{SW}) to ground voltage must remain at or below the *Absolute Maximum Ratings*.
- (2) Measurement made with six 10 μF (TDK C3216X5R1C106KT or equivalent) ceramic capacitors placed across V_{IN} to P_{GND} pins.
- (3) System conditions as defined in Note 1. Peak output current is applied for $t_p = 50\text{ }\mu\text{s}$.

6.4 Thermal Information

 $T_A = 25^\circ\text{C}$ (unless otherwise noted)

THERMAL METRIC		MIN	TYP	MAX	UNIT
$R_{\theta JC}$	Junction-to-case thermal resistance (top of package) ⁽¹⁾			15	$^\circ\text{C/W}$
$R_{\theta JB}$	Junction-to-board thermal resistance ⁽²⁾			1.5	$^\circ\text{C/W}$

- (1) $R_{\theta JC}$ is determined with the device mounted on a 1 inch² (6.45 cm²), 2 oz (0.071 mm thick) Cu pad on a 1.5 inches x 1.5 inches, 0.06 inch (1.52 mm) thick FR4 board.
- (2) $R_{\theta JB}$ value based on hottest board temperature within 1 mm of the package.

7 Application Schematic

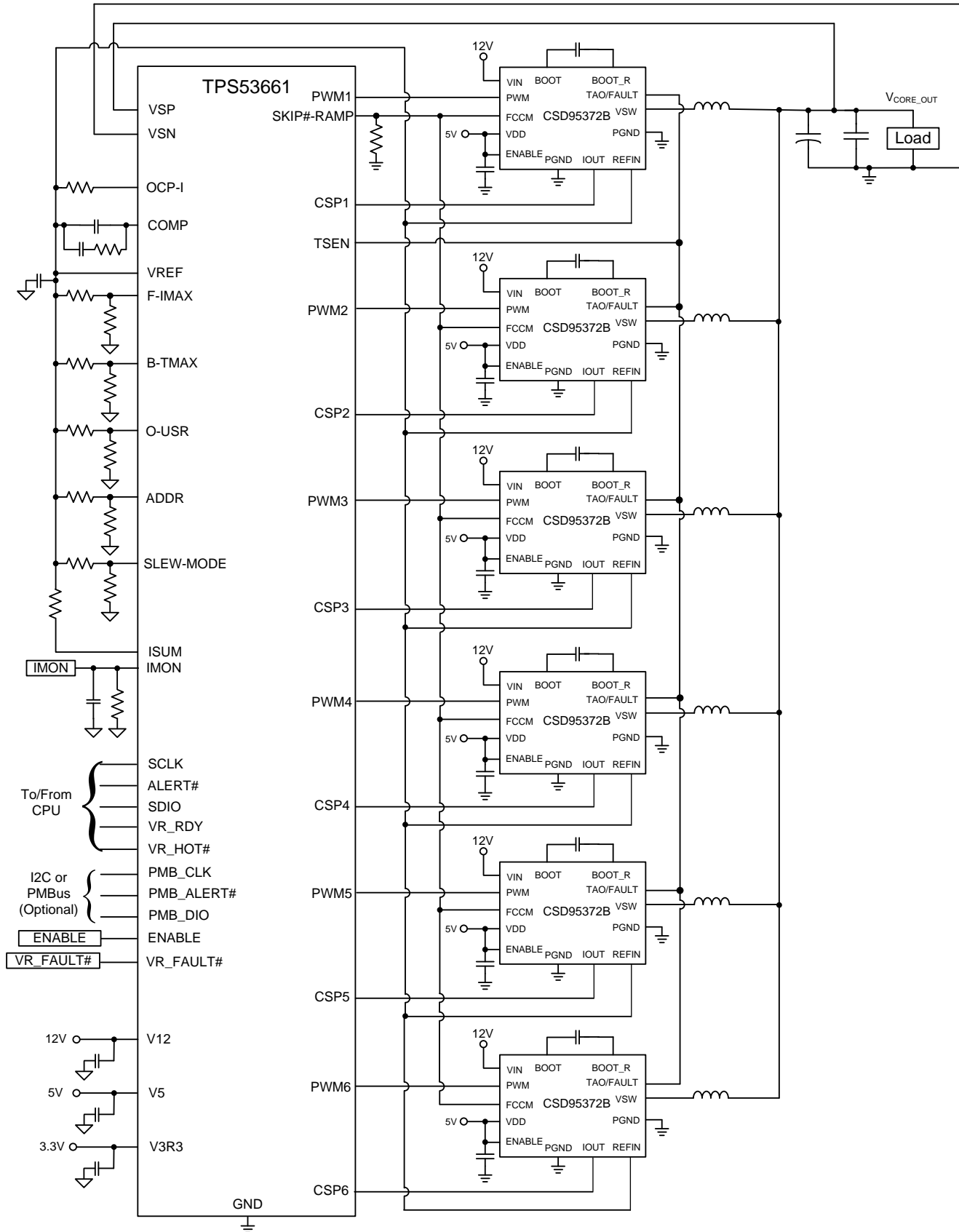

8 Device and Documentation Support

8.1 Trademarks

NexFET, DualCool are trademarks of Texas Instruments.
All other trademarks are the property of their respective owners.

8.2 Electrostatic Discharge Caution



These devices have limited built-in ESD protection. The leads should be shorted together or the device placed in conductive foam during storage or handling to prevent electrostatic damage to the MOS gates.

8.3 Glossary

[SLYZ022](#) — *TI Glossary*.

This glossary lists and explains terms, acronyms, and definitions.

9 Mechanical, Packaging, and Orderable Information

The following pages include mechanical packaging and orderable information. This information is the most current data available for the designated devices. This data is subject to change without notice and revision of this document. For browser-based versions of this data sheet, refer to the left-hand navigation.

9.1 Mechanical Drawing

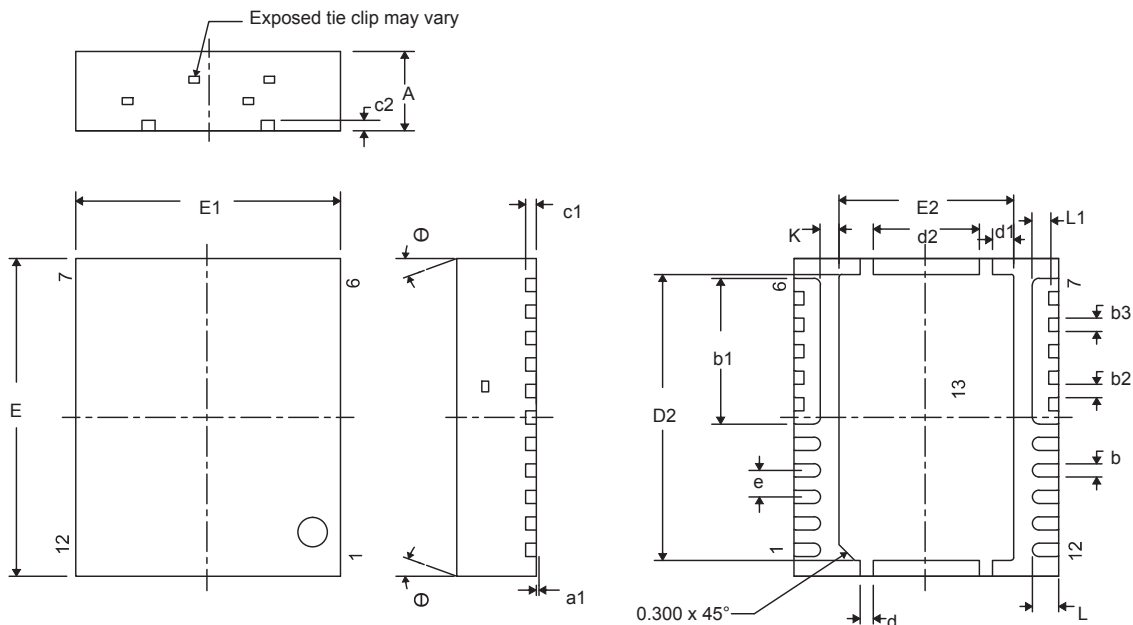

DIM	MILLIMETERS			INCHES		
	MIN	NOM	MAX	MIN	NOM	MAX
A	1.400	1.450	1.500	0.057	0.059	0.061
a1	0.000	0.000	0.050	0.000	0.000	0.002
b	0.200	0.250	0.320	0.008	0.010	0.013
b1	2.750 TYP			0.108 TYP		
b2	0.200	0.250	0.320	0.008	0.010	0.013
b3	0.250 TYP			0.010 TYP		
c1	0.150	0.200	0.250	0.006	0.008	0.010
c2	0.200	0.250	0.300	0.008	0.010	0.012
D2	5.300	5.400	5.500	0.209	0.213	0.217
d	0.200	0.250	0.300	0.008	0.010	0.012
d1	0.350	0.400	0.450	0.014	0.016	0.018
d2	1.900	2.000	2.100	0.075	0.079	0.083
E	5.900	6.000	6.100	0.232	0.236	0.240
E1	4.900	5.000	5.100	0.193	0.197	0.201
E2	3.200	3.300	3.400	0.126	0.130	0.134
e	0.500 TYP			0.020 TYP		
K	0.350 TYP			0.014 TYP		
L	0.400	0.500	0.600	0.016	0.020	0.024
L1	0.210	0.310	0.410	0.008	0.012	0.016
θ	0.00	—	—	0.00	—	—

9.2 Recommended PCB Land Pattern

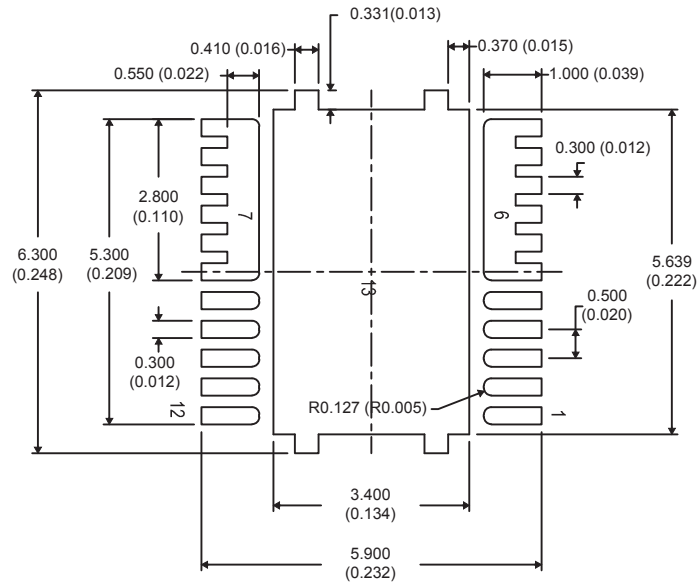

1. Dimensions are in mm (inches).

9.3 Recommended Stencil Opening

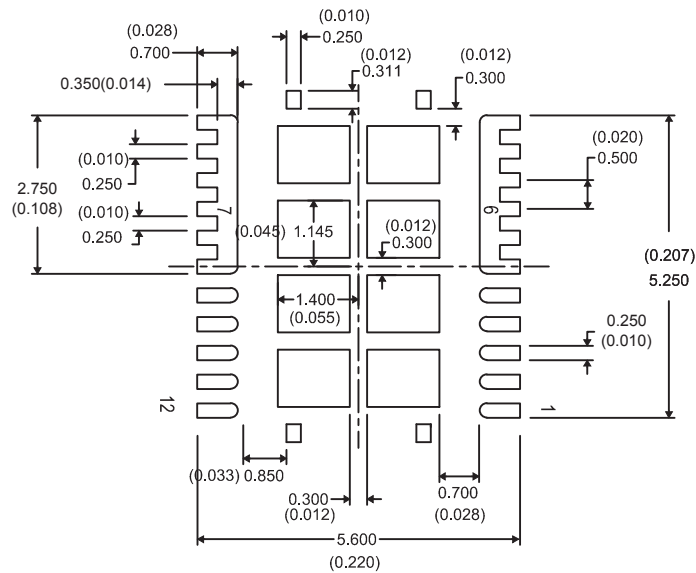

1. Dimensions are in mm (inches).
2. Stencil thickness is 100 μm .

PACKAGING INFORMATION

Orderable part number	Status (1)	Material type (2)	Package Pins	Package qty Carrier	RoHS (3)	Lead finish/ Ball material (4)	MSL rating/ Peak reflow (5)	Op temp (°C)	Part marking (6)
CSD95372BQ5M	Active	Production	LSON-CLIP (DQP) 12	2500 LARGE T&R	ROHS Exempt	NIPDAU	Level-2-260C-1 YEAR	-55 to 150	95372BM
CSD95372BQ5M.A	Active	Production	LSON-CLIP (DQP) 12	2500 LARGE T&R	ROHS Exempt	NIPDAU	Level-2-260C-1 YEAR	-55 to 150	95372BM
CSD95372BQ5M.B	Active	Production	LSON-CLIP (DQP) 12	2500 LARGE T&R	ROHS Exempt	NIPDAU	Level-2-260C-1 YEAR	-55 to 150	95372BM
CSD95372BQ5MG4	Active	Production	LSON-CLIP (DQP) 12	2500 LARGE T&R	ROHS Exempt	NIPDAU	Level-2-260C-1 YEAR	-55 to 150	95372BM
CSD95372BQ5MG4.A	Active	Production	LSON-CLIP (DQP) 12	2500 LARGE T&R	ROHS Exempt	NIPDAU	Level-2-260C-1 YEAR	-55 to 150	95372BM
CSD95372BQ5MG4.B	Active	Production	LSON-CLIP (DQP) 12	2500 LARGE T&R	ROHS Exempt	NIPDAU	Level-2-260C-1 YEAR	-55 to 150	95372BM
CSD95372BQ5MT	Active	Production	LSON-CLIP (DQP) 12	250 SMALL T&R	ROHS Exempt	NIPDAU SN	Level-2-260C-1 YEAR	-55 to 150	95372BM
CSD95372BQ5MT.A	Active	Production	LSON-CLIP (DQP) 12	250 SMALL T&R	ROHS Exempt	NIPDAU	Level-2-260C-1 YEAR	-55 to 150	95372BM
CSD95372BQ5MT.B	Active	Production	LSON-CLIP (DQP) 12	250 SMALL T&R	ROHS Exempt	NIPDAU	Level-2-260C-1 YEAR	-55 to 150	95372BM

(1) **Status:** For more details on status, see our [product life cycle](#).

(2) **Material type:** When designated, preproduction parts are prototypes/experimental devices, and are not yet approved or released for full production. Testing and final process, including without limitation quality assurance, reliability performance testing, and/or process qualification, may not yet be complete, and this item is subject to further changes or possible discontinuation. If available for ordering, purchases will be subject to an additional waiver at checkout, and are intended for early internal evaluation purposes only. These items are sold without warranties of any kind.

(3) **RoHS values:** Yes, No, RoHS Exempt. See the [TI RoHS Statement](#) for additional information and value definition.

(4) **Lead finish/Ball material:** Parts may have multiple material finish options. Finish options are separated by a vertical ruled line. Lead finish/Ball material values may wrap to two lines if the finish value exceeds the maximum column width.

(5) **MSL rating/Peak reflow:** The moisture sensitivity level ratings and peak solder (reflow) temperatures. In the event that a part has multiple moisture sensitivity ratings, only the lowest level per JEDEC standards is shown. Refer to the shipping label for the actual reflow temperature that will be used to mount the part to the printed circuit board.

(6) **Part marking:** There may be an additional marking, which relates to the logo, the lot trace code information, or the environmental category of the part.

Multiple part markings will be inside parentheses. Only one part marking contained in parentheses and separated by a "-" will appear on a part. If a line is indented then it is a continuation of the previous line and the two combined represent the entire part marking for that device.

Important Information and Disclaimer: The information provided on this page represents TI's knowledge and belief as of the date that it is provided. TI bases its knowledge and belief on information provided by third parties, and makes no representation or warranty as to the accuracy of such information. Efforts are underway to better integrate information from third parties. TI has taken and continues to take reasonable steps to provide representative

and accurate information but may not have conducted destructive testing or chemical analysis on incoming materials and chemicals. TI and TI suppliers consider certain information to be proprietary, and thus CAS numbers and other limited information may not be available for release.

In no event shall TI's liability arising out of such information exceed the total purchase price of the TI part(s) at issue in this document sold by TI to Customer on an annual basis.

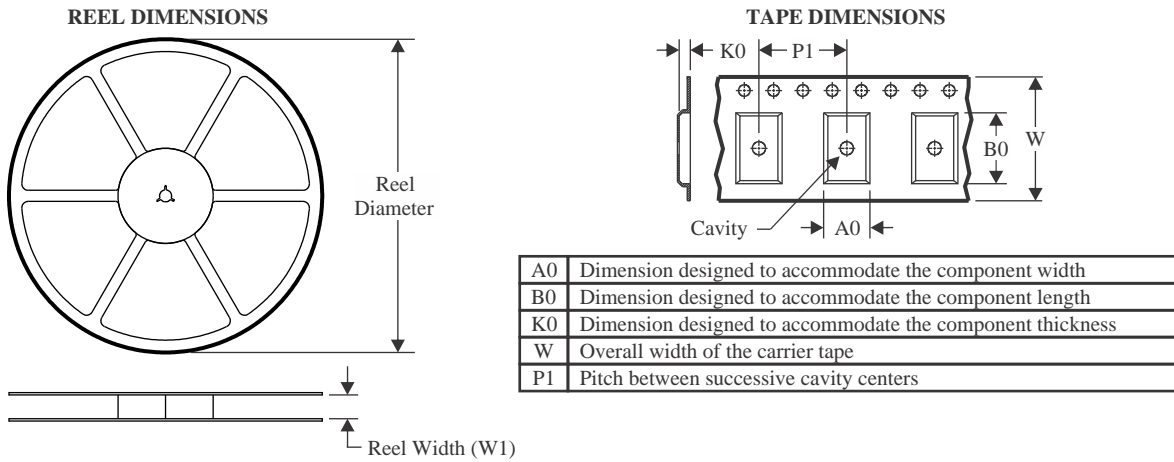
TAPE AND REEL INFORMATION

QUADRANT ASSIGNMENTS FOR PIN 1 ORIENTATION IN TAPE

*All dimensions are nominal

Device	Package Type	Package Drawing	Pins	SPQ	Reel Diameter (mm)	Reel Width W1 (mm)	A0 (mm)	B0 (mm)	K0 (mm)	P1 (mm)	W (mm)	Pin1 Quadrant
CSD95372BQ5M	LSON-CLIP	DQP	12	2500	330.0	12.4	5.3	6.3	1.8	8.0	12.0	Q1
CSD95372BQ5MG4	LSON-CLIP	DQP	12	2500	330.0	12.4	5.3	6.3	1.8	8.0	12.0	Q1
CSD95372BQ5MT	LSON-CLIP	DQP	12	250	180.0	12.4	5.3	6.3	1.8	8.0	12.0	Q1

TAPE AND REEL BOX DIMENSIONS



*All dimensions are nominal

Device	Package Type	Package Drawing	Pins	SPQ	Length (mm)	Width (mm)	Height (mm)
CSD95372BQ5M	LSON-CLIP	DQP	12	2500	346.0	346.0	33.0
CSD95372BQ5MG4	LSON-CLIP	DQP	12	2500	346.0	346.0	33.0
CSD95372BQ5MT	LSON-CLIP	DQP	12	250	210.0	185.0	35.0

IMPORTANT NOTICE AND DISCLAIMER

TI PROVIDES TECHNICAL AND RELIABILITY DATA (INCLUDING DATA SHEETS), DESIGN RESOURCES (INCLUDING REFERENCE DESIGNS), APPLICATION OR OTHER DESIGN ADVICE, WEB TOOLS, SAFETY INFORMATION, AND OTHER RESOURCES "AS IS" AND WITH ALL FAULTS, AND DISCLAIMS ALL WARRANTIES, EXPRESS AND IMPLIED, INCLUDING WITHOUT LIMITATION ANY IMPLIED WARRANTIES OF MERCHANTABILITY, FITNESS FOR A PARTICULAR PURPOSE OR NON-INFRINGEMENT OF THIRD PARTY INTELLECTUAL PROPERTY RIGHTS.

These resources are intended for skilled developers designing with TI products. You are solely responsible for (1) selecting the appropriate TI products for your application, (2) designing, validating and testing your application, and (3) ensuring your application meets applicable standards, and any other safety, security, regulatory or other requirements.

These resources are subject to change without notice. TI grants you permission to use these resources only for development of an application that uses the TI products described in the resource. Other reproduction and display of these resources is prohibited. No license is granted to any other TI intellectual property right or to any third party intellectual property right. TI disclaims responsibility for, and you will fully indemnify TI and its representatives against, any claims, damages, costs, losses, and liabilities arising out of your use of these resources.

TI's products are provided subject to [TI's Terms of Sale](#) or other applicable terms available either on [ti.com](#) or provided in conjunction with such TI products. TI's provision of these resources does not expand or otherwise alter TI's applicable warranties or warranty disclaimers for TI products.

TI objects to and rejects any additional or different terms you may have proposed.

Mailing Address: Texas Instruments, Post Office Box 655303, Dallas, Texas 75265
Copyright © 2025, Texas Instruments Incorporated