

SN54ALS541, SN74ALS540, SN74ALS541 OCTAL BUFFERS AND LINE DRIVERS WITH 3-STATE OUTPUTS

SDAS025D – APRIL 1982 – REVISED MARCH 2002

- 3-State Outputs Drive Bus Lines or Buffer Memory Address Registers
- pnp Inputs Reduce dc Loading
- Data Flowthrough Pinout (All Inputs on Opposite Side From Outputs)

description

These octal buffers and line drivers are designed to have the performance of the popular SN54ALS240A/SN74ALS240A series and, at the same time, offer a pinout with inputs and outputs on opposite sides of the package. This arrangement greatly facilitates printed circuit board layout.

The 3-state control gate is a 2-input NOR gate such that, if either output-enable ($\overline{OE1}$ or $\overline{OE2}$) input is high, all eight outputs are in the high-impedance state.

The SN74ALS540 provides inverted data. The 'ALS541 provide true data at the outputs.

The -1 versions of SN74ALS540 and SN74ALS541 are identical to the standard versions, except that the recommended maximum I_{OL} is increased to 48 mA. There is no -1 version of the SN54ALS541.

SN54ALS541 . . . J PACKAGE
SN74ALS540 . . . DW, N, OR NS PACKAGE
SN74ALS541 . . . DB, DW, N, OR NS PACKAGE
(TOP VIEW)

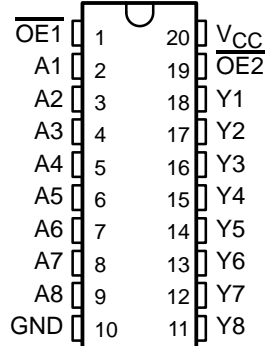

SN54ALS541 . . . FK PACKAGE
(TOP VIEW)

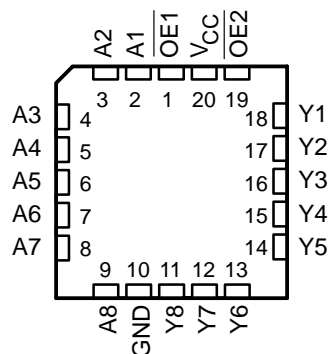

Please be aware that an important notice concerning availability, standard warranty, and use in critical applications of Texas Instruments semiconductor products and disclaimers thereto appears at the end of this data sheet.

PRODUCTION DATA information is current as of publication date. Products conform to specifications per the terms of Texas Instruments standard warranty. Production processing does not necessarily include testing of all parameters.

 **TEXAS
INSTRUMENTS**

POST OFFICE BOX 655303 • DALLAS, TEXAS 75265

Copyright © 2002, Texas Instruments Incorporated
On products compliant to MIL-PRF-38535, all parameters are tested unless otherwise noted. On all other products, production processing does not necessarily include testing of all parameters.

SN54ALS541, SN74ALS540, SN74ALS541 OCTAL BUFFERS AND LINE DRIVERS WITH 3-STATE OUTPUTS

SDAS025D – APRIL 1982 – REVISED MARCH 2002

ORDERING INFORMATION

T _A	PACKAGE†		ORDERABLE PART NUMBER	TOP-SIDE MARKING
0°C to 70°C	PDIP – N	Tube	SN74ALS540N	SN74ALS540N
			SN74ALS540-1N	SN74ALS540-1N
			SN74ALS541N	SN74ALS541N
			SN74ALS541-1N	SN74ALS541-1N
	SOIC – DW	Tube	SN74ALS540DW	ALS540
		Tape and reel	SN74ALS540DWR	
		Tube	SN74ALS540-1DW	ALS540-1
		Tube	SN74ALS541DW	
		Tape and reel	SN74ALS541DWR	ALS541
		Tube	SN74ALS541-1DW	
	SOP – NS	Tape and reel	SN74ALS540NSR	ALS540
			SN74ALS540-1NSR	ALS540-1
			SN74ALS541NSR	ALS541
	SSOP – DB	Tape and reel	SN74ALS541DBR	G541
SN74ALS541-1DBR			G541-1	
–55°C to 125°C	CDIP – J	Tube	SNJ54ALS541J	SNJ54ALS541J
	LCCC – FK	Tube	SNJ54ALS541FK	SNJ54ALS541FK

† Package drawings, standard packing quantities, thermal data, symbolization, and PCB design guidelines are available at www.ti.com/sc/package.

logic diagrams (positive logic)

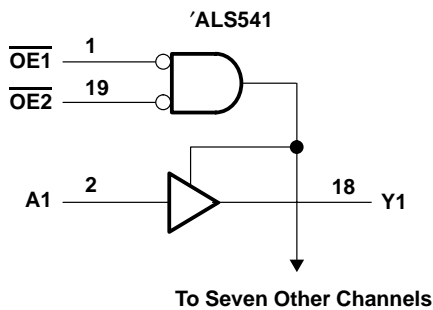
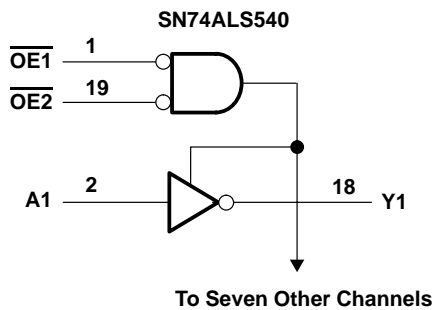

SN54ALS541, SN74ALS540, SN74ALS541 OCTAL BUFFERS AND LINE DRIVERS WITH 3-STATE OUTPUTS

SDAS025D – APRIL 1982 – REVISED MARCH 2002

absolute maximum ratings over operating free-air temperature (unless otherwise noted)[†]

Supply voltage, V_{CC}	7 V	
Input voltage, V_I	7 V	
Voltage applied to a disabled 3-state output	5.5 V	
Package thermal impedance, θ_{JA} (see Note 1):	DB package	70°C/W
	DW package	58°C/W
	N package	69°C/W
	NS package	60°C/W
Storage temperature range, T_{stg}	–65°C to 150°C	

[†] Stresses beyond those listed under “absolute maximum ratings” may cause permanent damage to the device. These are stress ratings only, and functional operation of the device at these or any other conditions beyond those indicated under “recommended operating conditions” is not implied. Exposure to absolute-maximum-rated conditions for extended periods may affect device reliability.

NOTE 1: The package thermal impedance is calculated in accordance with JESD 51-7.

recommended operating conditions

	SN54ALS541			SN74ALS540 SN74ALS541			UNIT
	MIN	NOM	MAX	MIN	NOM	MAX	
V_{CC} Supply voltage	4.5	5	5.5	4.5	5	5.5	V
V_{IH} High-level input voltage	2			2			V
V_{IL} Low-level input voltage			0.7			0.8	V
I_{OH} High-level output current			–12			–15	mA
I_{OL} Low-level output current			12			24	mA
						48 [†]	
T_A Operating free-air temperature	–55		125	0		70	°C

[†] Applies only to the -1 version and only if V_{CC} is between 4.75 V and 5.25 V



SN54ALS541, SN74ALS540, SN74ALS541

OCTAL BUFFERS AND LINE DRIVERS

WITH 3-STATE OUTPUTS

SDAS025D – APRIL 1982 – REVISED MARCH 2002

electrical characteristics over recommended operating free-air temperature range (unless otherwise noted)

PARAMETER	TEST CONDITIONS		SN54ALS541			SN74ALS540 SN74ALS541			UNIT
			MIN	TYP [‡]	MAX	MIN	TYP [‡]	MAX	
V _{IK}	V _{CC} = 4.5 V, I _I = -18 mA		-1.2			-1.2			V
V _{OH}	V _{CC} = 4.5 V to 5.5 V, I _{OH} = -0.4 mA		V _{CC} - 2			V _{CC} - 2			V
	V _{CC} = 4.5 V	I _{OH} = -3 mA	2.4	3.2	2.4	3.2			
		I _{OH} = -12 mA	2		2				
V _{OL}	V _{CC} = 4.5 V	I _{OL} = 12 mA	0.25 0.4		0.25 0.4				
		I _{OL} = 24 mA			0.35 0.5				
		I _{OL} = 48 mA [†]			0.35 0.5				
I _{OZH}	V _{CC} = 5.5 V, V _O = 2.7 V	20			20			μA	
I _{OZL}	V _{CC} = 5.5 V, V _O = 0.4 V	-20			-20			μA	
I _I	V _{CC} = 5.5 V, V _I = 7 V	0.1			0.1			mA	
I _{IH}	V _{CC} = 5.5 V, V _I = 2.7 V	20			20			μA	
I _{IL}	V _{CC} = 5.5 V, V _I = 0.4 V	-0.2			-0.1			mA	
I _O [§]	V _{CC} = 5.5 V, V _O = 2.25 V	-20	-112		-30	-112		mA	
I _{CC}	SN74ALS540	V _{CC} = 5.5 V	Outputs high		5 10				
			Outputs low		13 22				
			Outputs disabled		11 19				
	'ALS541	V _{CC} = 5.5 V	Outputs high		6	14	6	14	
			Outputs low		15	25	15	25	
			Outputs disabled		13.5	32	13.5	22	

[†] Applies only to the -1 version and only if V_{CC} is between 4.75 V and 5.25 V

[‡] All typical values are at V_{CC} = 5 V, T_A = 25°C.

[§] The output conditions have been chosen to produce a current that closely approximates one-half of the true short-circuit output current, I_{OS}.

switching characteristics (see Figure 1)

PARAMETER	FROM (INPUT)	TO (OUTPUT)	V _{CC} = 4.5 V to 5.5 V, C _L = 50 pF, R1 = 500 Ω, R2 = 500 Ω, T _A = MIN to MAX [†]						UNIT
			SN54ALS541		SN74ALS540		SN74ALS541		
			MIN	MAX	MIN	MAX	MIN	MAX	
t _{PLH}	A	Y	4	17	2	12	4	14	ns
t _{PHL}			2	14	2	9	2	10	
t _{PZH}	\overline{OE}	Y	5	18	5	15	5	15	ns
t _{PZL}			8	28	8	20	8	20	
t _{PHZ}	\overline{OE}	Y	1	12	1	10	1	10	ns
t _{PLZ}			2	14	2	12	2	12	

[†] For conditions shown as MIN or MAX, use the appropriate value specified under recommended operating conditions.



PARAMETER MEASUREMENT INFORMATION
 SERIES 54ALS/74ALS AND 54AS/74AS DEVICES

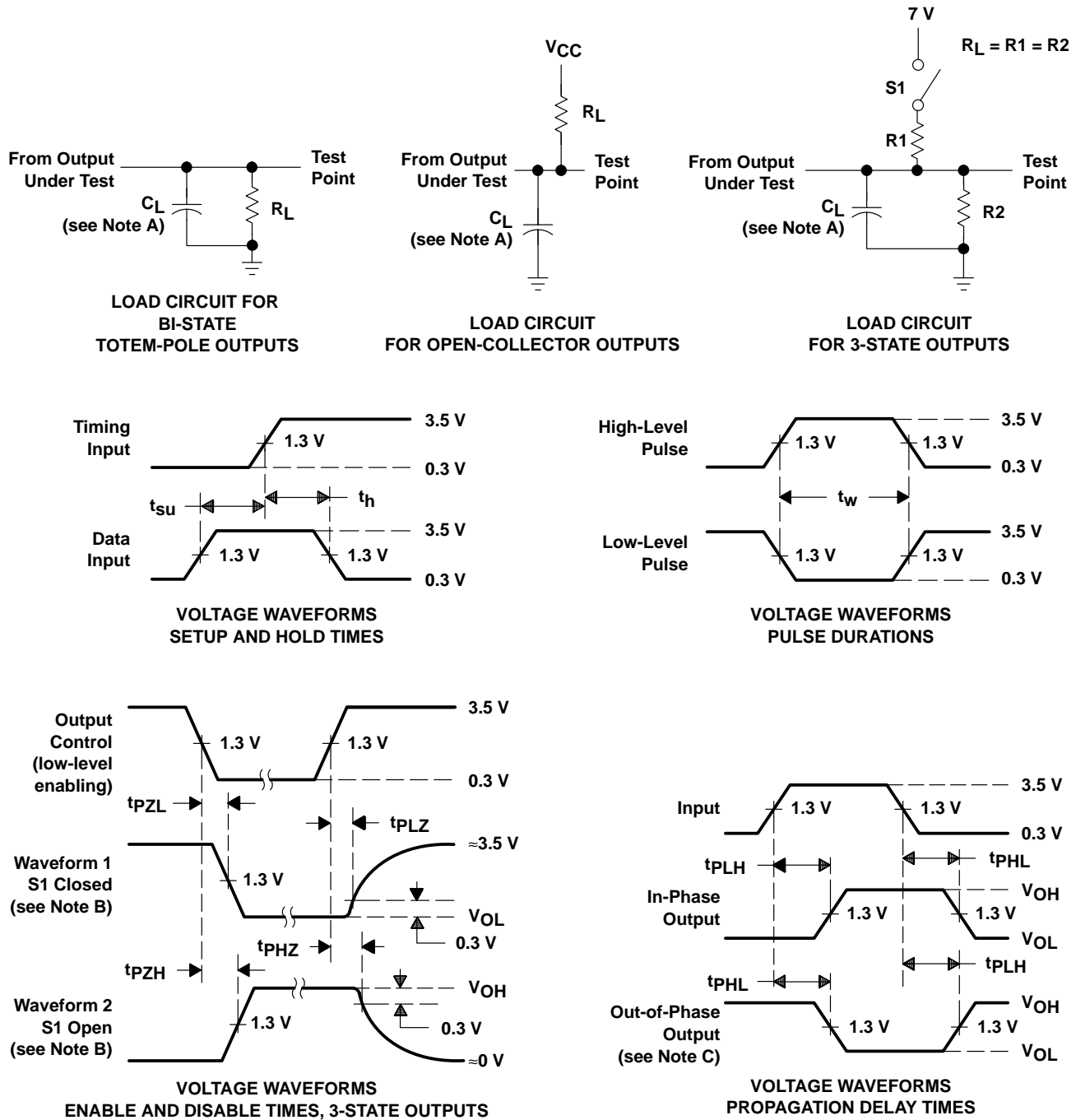

- NOTES: A. C_L includes probe and jig capacitance.
 B. Waveform 1 is for an output with internal conditions such that the output is low except when disabled by the output control. Waveform 2 is for an output with internal conditions such that the output is high except when disabled by the output control.
 C. When measuring propagation delay items of 3-state outputs, switch S1 is open.
 D. All input pulses have the following characteristics: $PRR \leq 1$ MHz, $t_r = t_f = 2$ ns, duty cycle = 50%.
 E. The outputs are measured one at a time with one transition per measurement.

Figure 1. Load Circuits and Voltage Waveforms

PACKAGING INFORMATION

Orderable part number	Status (1)	Material type (2)	Package Pins	Package qty Carrier	RoHS (3)	Lead finish/ Ball material (4)	MSL rating/ Peak reflow (5)	Op temp (°C)	Part marking (6)
5962-8960201RA	Active	Production	CDIP (J) 20	20 TUBE	No	SNPB	N/A for Pkg Type	-55 to 125	5962-8960201RA SNJ54ALS541J
SN54ALS541J	Active	Production	CDIP (J) 20	20 TUBE	No	SNPB	N/A for Pkg Type	-55 to 125	SN54ALS541J
SN54ALS541J.A	Active	Production	CDIP (J) 20	20 TUBE	No	SNPB	N/A for Pkg Type	-55 to 125	SN54ALS541J
SN74ALS540-1N	Active	Production	PDIP (N) 20	20 TUBE	Yes	NIPDAU	N/A for Pkg Type	0 to 70	SN74ALS540-1N
SN74ALS540-1N.A	Active	Production	PDIP (N) 20	20 TUBE	Yes	NIPDAU	N/A for Pkg Type	0 to 70	SN74ALS540-1N
SN74ALS540-1NSR	Active	Production	SOP (NS) 20	2000 LARGE T&R	Yes	NIPDAU	Level-1-260C-UNLIM	0 to 70	ALS540-1
SN74ALS540-1NSR.A	Active	Production	SOP (NS) 20	2000 LARGE T&R	Yes	NIPDAU	Level-1-260C-UNLIM	0 to 70	ALS540-1
SN74ALS540DW	Obsolete	Production	SOIC (DW) 20	-	-	Call TI	Call TI	0 to 70	ALS540
SN74ALS540DWR	Active	Production	SOIC (DW) 20	2000 LARGE T&R	Yes	NIPDAU	Level-1-260C-UNLIM	0 to 70	ALS540
SN74ALS540DWR.A	Active	Production	SOIC (DW) 20	2000 LARGE T&R	Yes	NIPDAU	Level-1-260C-UNLIM	0 to 70	ALS540
SN74ALS540N	Active	Production	PDIP (N) 20	20 TUBE	Yes	NIPDAU	N/A for Pkg Type	0 to 70	SN74ALS540N
SN74ALS540N.A	Active	Production	PDIP (N) 20	20 TUBE	Yes	NIPDAU	N/A for Pkg Type	0 to 70	SN74ALS540N
SN74ALS540NSR	Active	Production	SOP (NS) 20	2000 LARGE T&R	Yes	NIPDAU	Level-1-260C-UNLIM	0 to 70	ALS540
SN74ALS540NSR.A	Active	Production	SOP (NS) 20	2000 LARGE T&R	Yes	NIPDAU	Level-1-260C-UNLIM	0 to 70	ALS540
SN74ALS541-1DW	Active	Production	SOIC (DW) 20	25 TUBE	Yes	NIPDAU	Level-1-260C-UNLIM	0 to 70	ALS541-1
SN74ALS541-1DW.A	Active	Production	SOIC (DW) 20	25 TUBE	Yes	NIPDAU	Level-1-260C-UNLIM	0 to 70	ALS541-1
SN74ALS541-1N	Active	Production	PDIP (N) 20	20 TUBE	Yes	NIPDAU	N/A for Pkg Type	0 to 70	SN74ALS541-1N
SN74ALS541-1N.A	Active	Production	PDIP (N) 20	20 TUBE	Yes	NIPDAU	N/A for Pkg Type	0 to 70	SN74ALS541-1N
SN74ALS541-1NE4	Active	Production	PDIP (N) 20	20 TUBE	Yes	NIPDAU	N/A for Pkg Type	0 to 70	SN74ALS541-1N
SN74ALS541-1NSR	Active	Production	SOP (NS) 20	2000 LARGE T&R	Yes	NIPDAU	Level-1-260C-UNLIM	0 to 70	ALS541-1
SN74ALS541-1NSR.A	Active	Production	SOP (NS) 20	2000 LARGE T&R	Yes	NIPDAU	Level-1-260C-UNLIM	0 to 70	ALS541-1
SN74ALS541DBR	Active	Production	SSOP (DB) 20	2000 LARGE T&R	Yes	NIPDAU	Level-1-260C-UNLIM	0 to 70	G541
SN74ALS541DBR.A	Active	Production	SSOP (DB) 20	2000 LARGE T&R	Yes	NIPDAU	Level-1-260C-UNLIM	0 to 70	G541
SN74ALS541DW	Obsolete	Production	SOIC (DW) 20	-	-	Call TI	Call TI	0 to 70	ALS541
SN74ALS541DWR	Active	Production	SOIC (DW) 20	2000 LARGE T&R	Yes	NIPDAU	Level-1-260C-UNLIM	0 to 70	ALS541
SN74ALS541DWR.A	Active	Production	SOIC (DW) 20	2000 LARGE T&R	Yes	NIPDAU	Level-1-260C-UNLIM	0 to 70	ALS541
SN74ALS541N	Active	Production	PDIP (N) 20	20 TUBE	Yes	NIPDAU	N/A for Pkg Type	0 to 70	SN74ALS541N
SN74ALS541N.A	Active	Production	PDIP (N) 20	20 TUBE	Yes	NIPDAU	N/A for Pkg Type	0 to 70	SN74ALS541N

Orderable part number	Status (1)	Material type (2)	Package Pins	Package qty Carrier	RoHS (3)	Lead finish/ Ball material (4)	MSL rating/ Peak reflow (5)	Op temp (°C)	Part marking (6)
SN74ALS541NSR	Active	Production	SOP (NS) 20	2000 LARGE T&R	Yes	NIPDAU	Level-1-260C-UNLIM	0 to 70	ALS541
SN74ALS541NSR.A	Active	Production	SOP (NS) 20	2000 LARGE T&R	Yes	NIPDAU	Level-1-260C-UNLIM	0 to 70	ALS541
SN74ALS541NSRE4	Active	Production	SOP (NS) 20	2000 LARGE T&R	Yes	NIPDAU	Level-1-260C-UNLIM	0 to 70	ALS541
SNJ54ALS541J	Active	Production	CDIP (J) 20	20 TUBE	No	SNPB	N/A for Pkg Type	-55 to 125	5962-8960201RA SNJ54ALS541J
SNJ54ALS541J.A	Active	Production	CDIP (J) 20	20 TUBE	No	SNPB	N/A for Pkg Type	-55 to 125	5962-8960201RA SNJ54ALS541J

⁽¹⁾ **Status:** For more details on status, see our [product life cycle](#).

⁽²⁾ **Material type:** When designated, preproduction parts are prototypes/experimental devices, and are not yet approved or released for full production. Testing and final process, including without limitation quality assurance, reliability performance testing, and/or process qualification, may not yet be complete, and this item is subject to further changes or possible discontinuation. If available for ordering, purchases will be subject to an additional waiver at checkout, and are intended for early internal evaluation purposes only. These items are sold without warranties of any kind.

⁽³⁾ **RoHS values:** Yes, No, RoHS Exempt. See the [TI RoHS Statement](#) for additional information and value definition.

⁽⁴⁾ **Lead finish/Ball material:** Parts may have multiple material finish options. Finish options are separated by a vertical ruled line. Lead finish/Ball material values may wrap to two lines if the finish value exceeds the maximum column width.

⁽⁵⁾ **MSL rating/Peak reflow:** The moisture sensitivity level ratings and peak solder (reflow) temperatures. In the event that a part has multiple moisture sensitivity ratings, only the lowest level per JEDEC standards is shown. Refer to the shipping label for the actual reflow temperature that will be used to mount the part to the printed circuit board.

⁽⁶⁾ **Part marking:** There may be an additional marking, which relates to the logo, the lot trace code information, or the environmental category of the part.

Multiple part markings will be inside parentheses. Only one part marking contained in parentheses and separated by a "~" will appear on a part. If a line is indented then it is a continuation of the previous line and the two combined represent the entire part marking for that device.

Important Information and Disclaimer: The information provided on this page represents TI's knowledge and belief as of the date that it is provided. TI bases its knowledge and belief on information provided by third parties, and makes no representation or warranty as to the accuracy of such information. Efforts are underway to better integrate information from third parties. TI has taken and continues to take reasonable steps to provide representative and accurate information but may not have conducted destructive testing or chemical analysis on incoming materials and chemicals. TI and TI suppliers consider certain information to be proprietary, and thus CAS numbers and other limited information may not be available for release.

In no event shall TI's liability arising out of such information exceed the total purchase price of the TI part(s) at issue in this document sold by TI to Customer on an annual basis.

OTHER QUALIFIED VERSIONS OF SN54ALS541, SN74ALS541 :

- Catalog : [SN74ALS541](#)

- Military : [SN54ALS541](#)

NOTE: Qualified Version Definitions:

- Catalog - TI's standard catalog product
- Military - QML certified for Military and Defense Applications

TAPE AND REEL INFORMATION

QUADRANT ASSIGNMENTS FOR PIN 1 ORIENTATION IN TAPE

*All dimensions are nominal

Device	Package Type	Package Drawing	Pins	SPQ	Reel Diameter (mm)	Reel Width W1 (mm)	A0 (mm)	B0 (mm)	K0 (mm)	P1 (mm)	W (mm)	Pin1 Quadrant
SN74ALS540-1NSR	SOP	NS	20	2000	330.0	24.4	8.4	13.0	2.5	12.0	24.0	Q1
SN74ALS540DWR	SOIC	DW	20	2000	330.0	24.4	10.8	13.3	2.7	12.0	24.0	Q1
SN74ALS540NSR	SOP	NS	20	2000	330.0	24.4	8.4	13.0	2.5	12.0	24.0	Q1
SN74ALS541-1NSR	SOP	NS	20	2000	330.0	24.4	8.4	13.0	2.5	12.0	24.0	Q1
SN74ALS541DBR	SSOP	DB	20	2000	330.0	16.4	8.2	7.5	2.5	12.0	16.0	Q1
SN74ALS541DWR	SOIC	DW	20	2000	330.0	24.4	10.8	13.3	2.7	12.0	24.0	Q1
SN74ALS541NSR	SOP	NS	20	2000	330.0	24.4	8.4	13.0	2.5	12.0	24.0	Q1

TAPE AND REEL BOX DIMENSIONS

*All dimensions are nominal

Device	Package Type	Package Drawing	Pins	SPQ	Length (mm)	Width (mm)	Height (mm)
SN74ALS540-1NSR	SOP	NS	20	2000	367.0	367.0	45.0
SN74ALS540DWR	SOIC	DW	20	2000	367.0	367.0	45.0
SN74ALS540NSR	SOP	NS	20	2000	367.0	367.0	45.0
SN74ALS541-1NSR	SOP	NS	20	2000	367.0	367.0	45.0
SN74ALS541DBR	SSOP	DB	20	2000	356.0	356.0	35.0
SN74ALS541DWR	SOIC	DW	20	2000	367.0	367.0	45.0
SN74ALS541NSR	SOP	NS	20	2000	367.0	367.0	45.0

TUBE

*All dimensions are nominal

Device	Package Name	Package Type	Pins	SPQ	L (mm)	W (mm)	T (μm)	B (mm)
SN74ALS540-1N	N	PDIP	20	20	506	13.97	11230	4.32
SN74ALS540-1N.A	N	PDIP	20	20	506	13.97	11230	4.32
SN74ALS540N	N	PDIP	20	20	506	13.97	11230	4.32
SN74ALS540N.A	N	PDIP	20	20	506	13.97	11230	4.32
SN74ALS541-1DW	DW	SOIC	20	25	507	12.83	5080	6.6
SN74ALS541-1DW.A	DW	SOIC	20	25	507	12.83	5080	6.6
SN74ALS541-1N	N	PDIP	20	20	506	13.97	11230	4.32
SN74ALS541-1N.A	N	PDIP	20	20	506	13.97	11230	4.32
SN74ALS541-1NE4	N	PDIP	20	20	506	13.97	11230	4.32
SN74ALS541N	N	PDIP	20	20	506	13.97	11230	4.32
SN74ALS541N.A	N	PDIP	20	20	506	13.97	11230	4.32

DB0020A



PACKAGE OUTLINE

SSOP - 2 mm max height

SMALL OUTLINE PACKAGE



4214851/B 08/2019

NOTES:

1. All linear dimensions are in millimeters. Any dimensions in parenthesis are for reference only. Dimensioning and tolerancing per ASME Y14.5M.
2. This drawing is subject to change without notice.
3. This dimension does not include mold flash, protrusions, or gate burrs. Mold flash, protrusions, or gate burrs shall not exceed 0.15 mm per side.
4. This dimension does not include interlead flash. Interlead flash shall not exceed 0.25 mm per side.
5. Reference JEDEC registration MO-150.

EXAMPLE BOARD LAYOUT

DB0020A

SSOP - 2 mm max height

SMALL OUTLINE PACKAGE



LAND PATTERN EXAMPLE
EXPOSED METAL SHOWN
SCALE: 10X

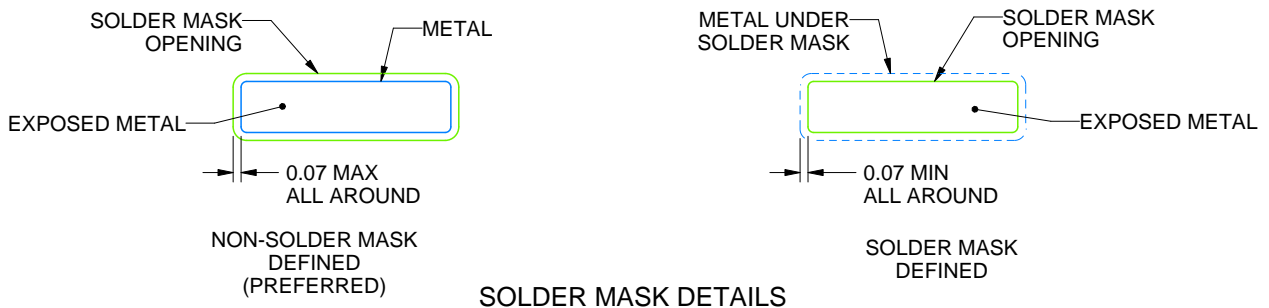

4214851/B 08/2019

NOTES: (continued)

- 6. Publication IPC-7351 may have alternate designs.
- 7. Solder mask tolerances between and around signal pads can vary based on board fabrication site.

EXAMPLE STENCIL DESIGN

DB0020A

SSOP - 2 mm max height

SMALL OUTLINE PACKAGE

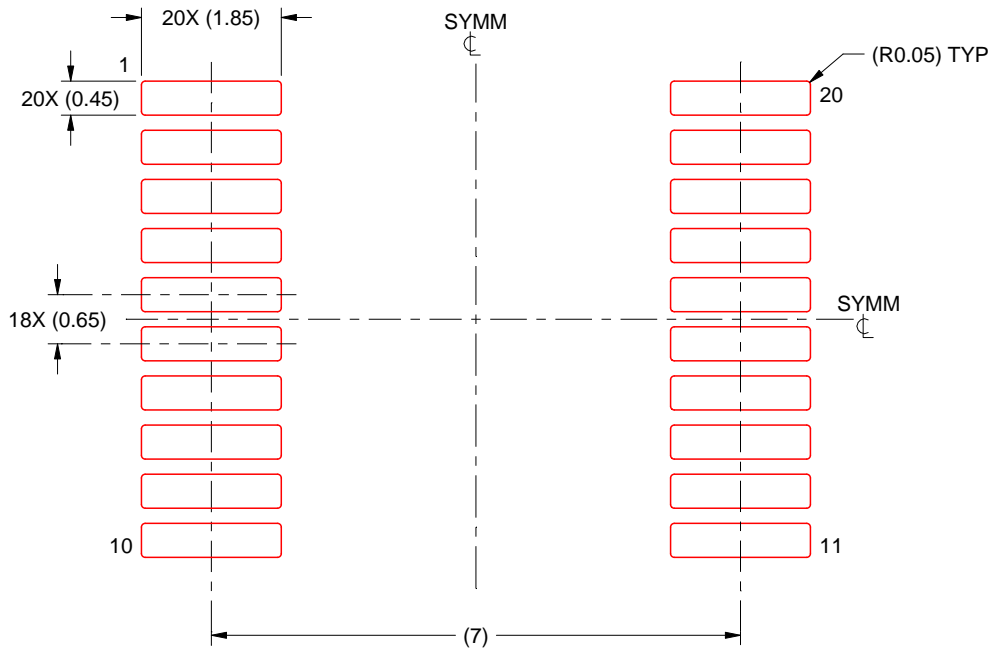

SOLDER PASTE EXAMPLE
BASED ON 0.125 mm THICK STENCIL
SCALE: 10X

4214851/B 08/2019

NOTES: (continued)

8. Laser cutting apertures with trapezoidal walls and rounded corners may offer better paste release. IPC-7525 may have alternate design recommendations.
9. Board assembly site may have different recommendations for stencil design.

MECHANICAL DATA

NS (R-PDSO-G**)

PLASTIC SMALL-OUTLINE PACKAGE

14-PINS SHOWN



- NOTES:
- A. All linear dimensions are in millimeters.
 - B. This drawing is subject to change without notice.
 - C. Body dimensions do not include mold flash or protrusion, not to exceed 0,15.

J (R-GDIP-T**)

14 LEADS SHOWN

CERAMIC DUAL IN-LINE PACKAGE



DIM \ PINS **	14	16	18	20
A	0.300 (7,62) BSC	0.300 (7,62) BSC	0.300 (7,62) BSC	0.300 (7,62) BSC
B MAX	0.785 (19,94)	.840 (21,34)	0.960 (24,38)	1.060 (26,92)
B MIN	—	—	—	—
C MAX	0.300 (7,62)	0.300 (7,62)	0.310 (7,87)	0.300 (7,62)
C MIN	0.245 (6,22)	0.245 (6,22)	0.220 (5,59)	0.245 (6,22)



4040083/F 03/03

- NOTES:
- All linear dimensions are in inches (millimeters).
 - This drawing is subject to change without notice.
 - This package is hermetically sealed with a ceramic lid using glass frit.
 - Index point is provided on cap for terminal identification only on press ceramic glass frit seal only.
 - Falls within MIL STD 1835 GDIP1-T14, GDIP1-T16, GDIP1-T18 and GDIP1-T20.

N (R-PDIP-T**)

PLASTIC DUAL-IN-LINE PACKAGE

16 PINS SHOWN



- NOTES:
- A. All linear dimensions are in inches (millimeters).
 - B. This drawing is subject to change without notice.
 - C. Falls within JEDEC MS-001, except 18 and 20 pin minimum body length (Dim A).
 - D. The 20 pin end lead shoulder width is a vendor option, either half or full width.

DW0020A



PACKAGE OUTLINE

SOIC - 2.65 mm max height

SOIC



4220724/A 05/2016

NOTES:

1. All linear dimensions are in millimeters. Dimensions in parenthesis are for reference only. Dimensioning and tolerancing per ASME Y14.5M.
2. This drawing is subject to change without notice.
3. This dimension does not include mold flash, protrusions, or gate burrs. Mold flash, protrusions, or gate burrs shall not exceed 0.15 mm per side.
4. This dimension does not include interlead flash. Interlead flash shall not exceed 0.43 mm per side.
5. Reference JEDEC registration MS-013.

EXAMPLE BOARD LAYOUT

DW0020A

SOIC - 2.65 mm max height

SOIC



LAND PATTERN EXAMPLE
SCALE:6X



SOLDER MASK DETAILS

4220724/A 05/2016

NOTES: (continued)

- 6. Publication IPC-7351 may have alternate designs.
- 7. Solder mask tolerances between and around signal pads can vary based on board fabrication site.

EXAMPLE STENCIL DESIGN

DW0020A

SOIC - 2.65 mm max height

SOIC



SOLDER PASTE EXAMPLE
BASED ON 0.125 mm THICK STENCIL
SCALE:6X

4220724/A 05/2016

NOTES: (continued)

8. Laser cutting apertures with trapezoidal walls and rounded corners may offer better paste release. IPC-7525 may have alternate design recommendations.
9. Board assembly site may have different recommendations for stencil design.

IMPORTANT NOTICE AND DISCLAIMER

TI PROVIDES TECHNICAL AND RELIABILITY DATA (INCLUDING DATA SHEETS), DESIGN RESOURCES (INCLUDING REFERENCE DESIGNS), APPLICATION OR OTHER DESIGN ADVICE, WEB TOOLS, SAFETY INFORMATION, AND OTHER RESOURCES "AS IS" AND WITH ALL FAULTS, AND DISCLAIMS ALL WARRANTIES, EXPRESS AND IMPLIED, INCLUDING WITHOUT LIMITATION ANY IMPLIED WARRANTIES OF MERCHANTABILITY, FITNESS FOR A PARTICULAR PURPOSE OR NON-INFRINGEMENT OF THIRD PARTY INTELLECTUAL PROPERTY RIGHTS.

These resources are intended for skilled developers designing with TI products. You are solely responsible for (1) selecting the appropriate TI products for your application, (2) designing, validating and testing your application, and (3) ensuring your application meets applicable standards, and any other safety, security, regulatory or other requirements.

These resources are subject to change without notice. TI grants you permission to use these resources only for development of an application that uses the TI products described in the resource. Other reproduction and display of these resources is prohibited. No license is granted to any other TI intellectual property right or to any third party intellectual property right. TI disclaims responsibility for, and you will fully indemnify TI and its representatives against, any claims, damages, costs, losses, and liabilities arising out of your use of these resources.

TI's products are provided subject to [TI's Terms of Sale](#) or other applicable terms available either on [ti.com](https://www.ti.com) or provided in conjunction with such TI products. TI's provision of these resources does not expand or otherwise alter TI's applicable warranties or warranty disclaimers for TI products.

TI objects to and rejects any additional or different terms you may have proposed.

Mailing Address: Texas Instruments, Post Office Box 655303, Dallas, Texas 75265

Copyright © 2025, Texas Instruments Incorporated