

# SN54221, SN54LS221, SN74221, SN74LS221 DUAL MONOSTABLE MULTIVIBRATORS WITH SCHMITT-TRIGGER INPUTS

SDLS213B – DECEMBER 1983 – REVISED NOVEMBER 2004

- Dual Versions of Highly Stable SN54121 and SN74121 One Shots
- SN54221 and SN74221 Demonstrate Electrical and Switching Characteristics That Are Virtually Identical to the SN54121 and SN74121 One Shots
- Pinout Is Identical to the SN54123, SN74123, SN54LS123, and SN74LS123
- Overriding Clear Terminates Output Pulse

TYPE	MAXIMUM OUTPUT PULSE LENGTH(S)
SN54221	21
SN74221	28
SN54LS221	49
SN74LS221	70

## description/ordering information

The '221 and 'LS221 devices are dual multivibrators with performance characteristics virtually identical to those of the '121 devices. Each multivibrator features a negative-transition-triggered input and a positive-transition-triggered input, either of which can be used as an inhibit input.

SN54221, SN54LS221 . . . J PACKAGE  
SN74221 . . . N PACKAGE  
SN74LS221 . . . D, DB, N, OR NS PACKAGE  
(TOP VIEW)

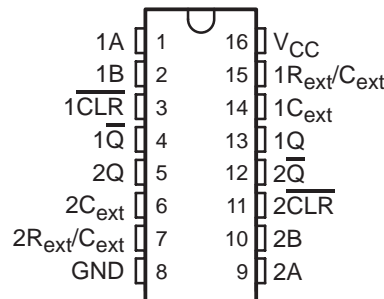

SN54LS221 . . . FK PACKAGE  
(TOP VIEW)

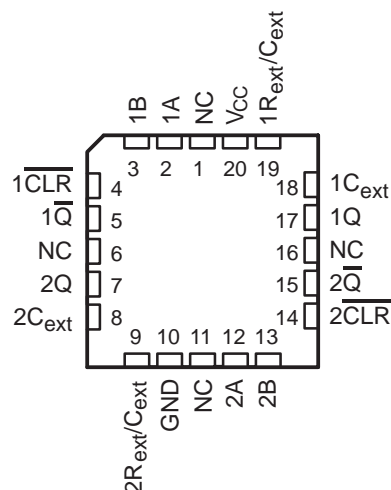

NC – No internal connection

## ORDERING INFORMATION

T <sub>A</sub>	PACKAGE†		ORDERABLE PART NUMBER	TOP-SIDE MARKING
0°C to 70°C	PDIP – N	Tube	SN74221N	SN74221N
			SN74LS221N	SN74LS221N
	SOIC – D	Tube	SN74LS221D	LS221
			Tape and reel	
		SOP – NS	Tape and reel	SN74LS221NSR
SSOP – DB	Tape and reel	SN74LS221DBR	LS221	
–55°C to 125°C	CDIP – J	Tube	SNJ54221J	SNJ54221J
			SNJ54LS221J	SNJ54LS221J
	LCCC – FK	Tube	SNJ54LS221FK	SNJ54LS221FK

† Package drawings, standard packing quantities, thermal data, symbolization, and PCB design guidelines are available at [www.ti.com/sc/package](http://www.ti.com/sc/package).



Please be aware that an important notice concerning availability, standard warranty, and use in critical applications of Texas Instruments semiconductor products and disclaimers thereto appears at the end of this data sheet.

PRODUCTION DATA information is current as of publication date. Products conform to specifications per the terms of Texas Instruments standard warranty. Production processing does not necessarily include testing of all parameters.

 **TEXAS  
INSTRUMENTS**

POST OFFICE BOX 655303 • DALLAS, TEXAS 75265

Copyright © 2004, Texas Instruments Incorporated  
On products compliant to MIL-PRF-38535, all parameters are tested unless otherwise noted. On all other products, production processing does not necessarily include testing of all parameters.

# SN54221, SN54LS221, SN74221, SN74LS221 DUAL MONOSTABLE MULTIVIBRATORS WITH SCHMITT-TRIGGER INPUTS

SDLS213B – DECEMBER 1983 – REVISED NOVEMBER 2004

## description/ordering information (continued)

Pulse triggering occurs at a particular voltage level and is not directly related to the transition time of the input pulse. Schmitt-trigger input circuitry (TTL hysteresis) for B input allows jitter-free triggering from inputs with transition at rates as slow as 1 V/s, providing the circuit with excellent noise immunity, typically of 1.2 V. A high immunity to  $V_{CC}$  noise, typically of 1.5 V, also is provided by internal latching circuitry.

Once fired, the outputs are independent of further transitions of the A and B inputs and are a function of the timing components, or the output pulses can be terminated by the overriding clear. Input pulses can be of any duration relative to the output pulse. Output pulse length can be varied from 35 ns to the maximum by choosing appropriate timing components. With  $R_{ext} = 2 \text{ k}\Omega$  and  $C_{ext} = 0$ , an output pulse typically of 30 ns is achieved that can be used as a dc-triggered reset signal. Output rise and fall times are TTL compatible and independent of pulse length. Typical triggering and clearing sequences are shown as a part of the switching characteristics waveforms.

Pulse-width stability is achieved through internal compensation and is virtually independent of  $V_{CC}$  and temperature. In most applications, pulse stability is limited only by the accuracy of external timing components.

Jitter-free operation is maintained over the full temperature and  $V_{CC}$  ranges for more than six decades of timing capacitance (10 pF to 10  $\mu\text{F}$ ) and more than one decade of timing resistance (2 k $\Omega$  to 30 k $\Omega$  for the SN54221, 2 k $\Omega$  to 40 k $\Omega$  for the SN74221, 2 k $\Omega$  to 70 k $\Omega$  for the SN54LS221, and 2 k $\Omega$  to 100 k $\Omega$  for the SN74LS221). Throughout these ranges, pulse width is defined by the relationship:  $t_w(\text{out}) = C_{ext}R_{ext} \ln 2 \approx 0.7 C_{ext}R_{ext}$ . In circuits where pulse cutoff is not critical, timing capacitance up to 1000  $\mu\text{F}$  and timing resistance as low as 1.4 k $\Omega$  can be used. Also, the range of jitter-free output pulse widths is extended if  $V_{CC}$  is held to 5 V and free-air temperature is 25°C. Duty cycles as high as 90% are achieved when using maximum recommended  $R_T$ . Higher duty cycles are available if a certain amount of pulse-width jitter is allowed.

The variance in output pulse width from device to device typically is less than  $\pm 0.5\%$  for given external timing components. An example of this distribution for the '221 is shown in Figure 3. Variations in output pulse width versus supply voltage and temperature for the '221 are shown in Figures 4 and 5, respectively.

Pin assignments for these devices are identical to those of the SN54123/SN74123 or SN54LS123/SN74LS123 so that the '221 or 'LS221 devices can be substituted for those products in systems not using the retrigger by merely changing the value of  $R_{ext}$  and/or  $C_{ext}$ ; however, the polarity of the capacitor must be changed.

**FUNCTION TABLE**  
(each monostable multivibrator)

INPUTS			OUTPUTS	
$\overline{\text{CLR}}$	A	B	Q	$\overline{\text{Q}}$
L	X	X	L	H
X	H	X	L	H
X	X	L	L	H
H	L	$\uparrow$		
H	$\downarrow$	H		
$\uparrow\ddagger$	L	H		

$\dagger$  Pulsed-output patterns are tested during AC switching at 25°C with  $R_{ext} = 2 \text{ k}\Omega$ , and  $C_{ext} = 80 \text{ pF}$ .

$\ddagger$  This condition is true only if the output of the latch formed by the two NAND gates has been conditioned to the logic 1 state prior to  $\overline{\text{CLR}}$  going high. This latch is conditioned by taking either A high or B low while  $\overline{\text{CLR}}$  is inactive (high).

**SN54221, SN54LS221, SN74221, SN74LS221**  
**DUAL MONOSTABLE MULTIVIBRATORS**  
**WITH SCHMITT-TRIGGER INPUTS**

SDLS213B – DECEMBER 1983 – REVISED NOVEMBER 2004

**timing component connections**

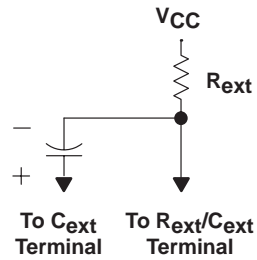

NOTE: Due to the internal circuit, the  $R_{ext}/C_{ext}$  terminal never is more positive than the  $C_{ext}$  terminal.

# SN54221, SN54LS221, SN74221, SN74LS221 DUAL MONOSTABLE MULTIVIBRATORS WITH SCHMITT-TRIGGER INPUTS

SDLS213B – DECEMBER 1983 – REVISED NOVEMBER 2004

## schematics of inputs and outputs

SN54/74221

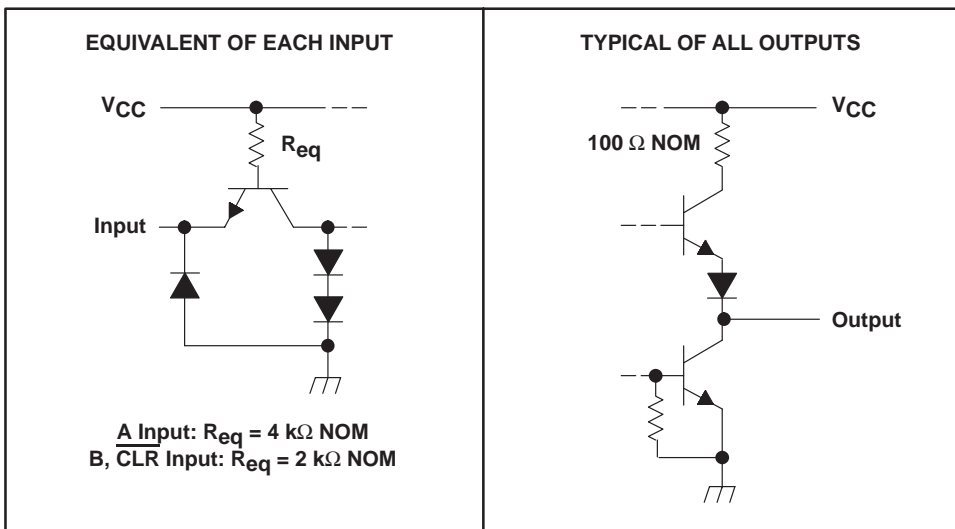

SN54/74LS221

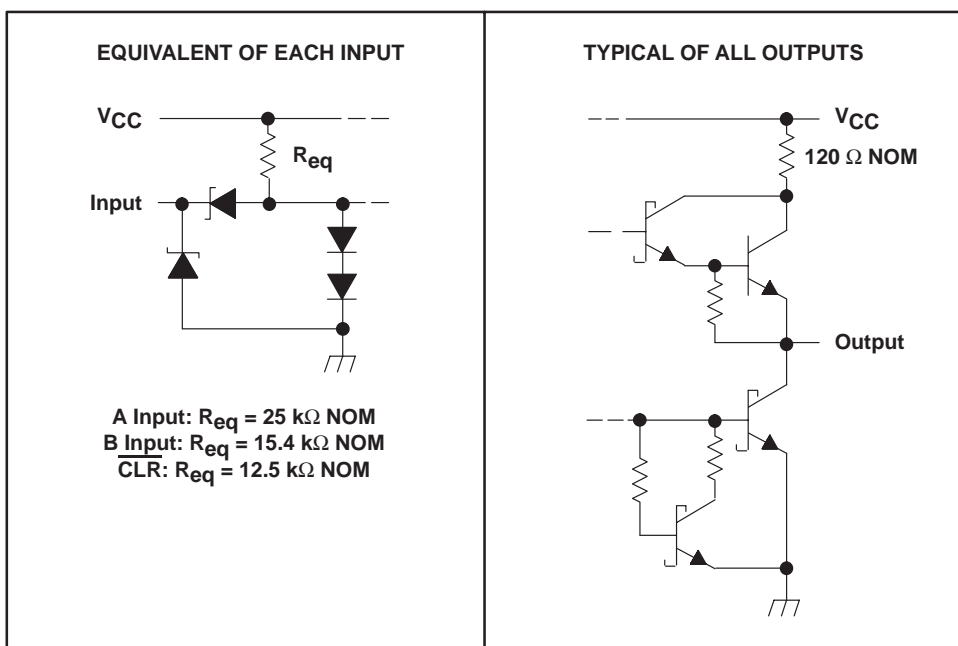

# SN54221, SN54LS221, SN74221, SN74LS221 DUAL MONOSTABLE MULTIVIBRATORS WITH SCHMITT-TRIGGER INPUTS

SDLS213B – DECEMBER 1983 – REVISED NOVEMBER 2004

## absolute maximum ratings over operating free-air temperature range (unless otherwise noted)†

Supply voltage range, $V_{CC}$ .....	7 V
Input voltage range, $V_I$ (see Note 1): 'LS221 .....	7 V
'221 .....	5.5 V
Package thermal impedance, $\theta_{JA}$ (see Note 2): D package .....	73°C/W
DB package .....	82°C/W
N package .....	67°C/W
NS package .....	64°C/W
Storage temperature range, $T_{stg}$ .....	–65°C to 150°C

† Stresses beyond those listed under “absolute maximum ratings” may cause permanent damage to the device. These are stress ratings only, and functional operation of the device at these or any other conditions beyond those indicated under “recommended operating conditions” is not implied. Exposure to absolute-maximum-rated conditions for extended periods may affect device reliability.

- NOTES: 1. The input and output negative-voltage ratings may be exceeded if the input and output clamp-current ratings are observed.  
2. The package thermal impedance is calculated in accordance with JESD 51-7.

## recommended operating conditions (see Note 3)

		SN54221			SN74221			UNIT
		MIN	NOM	MAX	MIN	NOM	MAX	
$V_{CC}$	Supply voltage	4.5	5	5.5	4.75	5	5.25	V
$I_{OH}$	High-level output current			–800			–800	$\mu$ A
$I_{OL}$	Low-level output current			16			16	mA
$\Delta v/\Delta t$	Rise or fall of input pulse rate	B input		1*	1			V/s
		A input		1*	1			V/ $\mu$ s
$T_A$	Operating free-air temperature	–55		125	0		70	°C

\* On products compliant to MIL-PRF-38535, this parameter is not production tested.

NOTE 3: All unused inputs of the device must be held at  $V_{CC}$  or GND to ensure proper device operation. Refer to the TI application report, *Implications of Slow or Floating CMOS Inputs*, literature number SCBA004.



# SN54221, SN54LS221, SN74221, SN74LS221 DUAL MONOSTABLE MULTIVIBRATORS WITH SCHMITT-TRIGGER INPUTS

SDLS213B – DECEMBER 1983 – REVISED NOVEMBER 2004

electrical characteristics over recommended operating free-air temperature range (unless otherwise noted)

PARAMETER		TEST CONDITIONS†	SN54221			SN74221			UNIT
			MIN	TYP‡	MAX	MIN	TYP‡	MAX	
$V_{T+}$	Positive-going threshold voltage, B input	$V_{CC} = \text{MIN}$	1.55		2*	1.55		2	V
$V_{T-}$	Negative-going threshold voltage, B input	$V_{CC} = \text{MIN}$	0.8*	1.35		0.8	1.35		V
$V_{IK}$		$V_{CC} = \text{MIN}$ , $I_I = -12 \text{ mA}$			-1.5			-1.5	V
$V_{OH}$		$V_{CC} = \text{MIN}$ , $I_{OH} = -800 \mu\text{A}$	2.4	3.4		2.4	3.4		V
$V_{OL}$		$V_{CC} = \text{MIN}$ , $I_{OL} = 16 \text{ mA}$	0.2	0.4		0.2	0.4		V
$I_I$		$V_{CC} = \text{MAX}$ , $V_I = 5.5 \text{ V}$			1			1	mA
$I_{IH}$	A input	$V_{CC} = \text{MAX}$ , $V_I = 2.4 \text{ V}$			40			40	$\mu\text{A}$
	$\overline{\text{CLR}}$ , B input				80			80	
$I_{IL}$	A input	$V_{CC} = \text{MAX}$ , $V_I = 0.4 \text{ V}$			-1.6			-1.6	mA
	$\overline{\text{CLR}}$ , B input				-3.2			-3.2	
$I_{OS}^{\S}$		$V_{CC} = \text{MAX}$	-20		-55	-18		-55	mA
$I_{CC}$	Quiescent	$V_{CC} = \text{MAX}$	26		50*	26		50	mA
	Triggered		46		80*	46		80	

\* On products compliant to MIL-PRF-38535, this parameter is not production tested.

† For conditions shown as MIN or MAX, use the appropriate value specified under recommended operating conditions.

‡ All typical values are at  $V_{CC} = 5 \text{ V}$ ,  $T_A = 25^\circ\text{C}$ .

§ Not more than one output should be shorted at a time, and the duration of the short circuit should not exceed one second.

## timing requirements over recommended ranges of supply voltage and operating free-air temperature

			SN54221		SN74221		UNIT
			MIN	MAX	MIN	MAX	
$t_w$	Pulse duration	A or B input	50		50		ns
		$\overline{\text{CLR}}$	20		20		
$t_{su}$	Setup time, inactive-state¶	$\overline{\text{CLR}}$	15		15		ns
$R_{ext}$	External timing resistance		1.4*	30*	1.4	40	k $\Omega$
$C_{ext}$	External timing capacitance		0*	1000*	0	1000	$\mu\text{F}$
	Output duty cycle	$R_{ext} = 2 \text{ k}\Omega$		67%		67%	
		$R_{ext} = \text{MAX } R_{ext}$		90%		90%	

\* On products compliant to MIL-PRF-38535, this parameter is not production tested.

¶ Inactive-state setup time also is referred to as recovery time.



# SN54221, SN54LS221, SN74221, SN74LS221 DUAL MONOSTABLE MULTIVIBRATORS WITH SCHMITT-TRIGGER INPUTS

SDLS213B – DECEMBER 1983 – REVISED NOVEMBER 2004

**switching characteristics  $V_{CC} = 5\text{ V}$ ,  $R_L = 400\ \Omega$ ,  $T_A = 25^\circ\text{C}$  (see Figures 1 and 2)**

PARAMETER	FROM (INPUT)	TO (OUTPUT)	TEST CONDITIONS	SN54221			SN74221			UNIT	
				MIN	TYP	MAX	MIN	TYP	MAX		
$t_{PLH}$	A	Q	$C_{ext} = 80\text{ pF}$ , $R_{ext} = 2\text{ k}\Omega$	45	70		45	70	ns		
	B			35	55		35	55			
$t_{PHL}$	A	$\overline{Q}$		50	80		50	80			
	B			40	65		40	65			
$t_{PHL}$	$\overline{CLR}$	Q		$C_{ext} = 80\text{ pF}$ , $R_{ext} = 2\text{ k}\Omega$	27			27			ns
$t_{PLH}$		$\overline{Q}$			40			40			
$t_w$	A or B	Q or $\overline{Q}$	$C_{ext} = 80\text{ pF}$ , $R_{ext} = 2\text{ k}\Omega$	70	110	150	70	110	150	ns	
			$C_{ext} = 0$ , $R_{ext} = 2\text{ k}\Omega$	17	30	50	17	30	50		
			$C_{ext} = 100\text{ pF}$ , $R_{ext} = 10\text{ k}\Omega$	650	700	750	650	700	750		
			$C_{ext} = 1\ \mu\text{F}$ , $R_{ext} = 10\text{ k}\Omega$	6.5*	7	7.5*	6.5	7	7.5		ms

\* On products compliant to MIL-PRF-38535, this parameter is not production tested.

## recommended operating conditions (see Note 4)

		SN54LS221			SN74LS221			UNIT
		MIN	NOM	MAX	MIN	NOM	MAX	
$V_{CC}$	Supply voltage	4.5	5	5.5	4.75	5	5.25	V
$I_{OH}$	High-level output current	-400			-400			$\mu\text{A}$
$I_{OL}$	Low-level output current	4			8			mA
$\Delta v/\Delta t$	Rise or fall of input pulse rate	B input	1*		1			V/s
		A input	1*		1			V/ $\mu\text{s}$
$T_A$	Operating free-air temperature	-55		125	0		70	$^\circ\text{C}$

\* On products compliant to MIL-PRF-38535, this parameter is not production tested.

NOTE 4: All unused inputs of the device must be held at  $V_{CC}$  or GND to ensure proper device operation. Refer to the TI application report, *Implications of Slow or Floating CMOS Inputs*, literature number SCBA004.

# SN54221, SN54LS221, SN74221, SN74LS221 DUAL MONOSTABLE MULTIVIBRATORS WITH SCHMITT-TRIGGER INPUTS

SDLS213B – DECEMBER 1983 – REVISED NOVEMBER 2004

electrical characteristics over recommended operating free-air temperature range (unless otherwise noted)

PARAMETER		TEST CONDITIONS†	SN54LS221			SN74LS221			UNIT
			MIN	TYP‡	MAX	MIN	TYP‡	MAX	
$V_{T+}$	Positive-going threshold voltage, B input	$V_{CC} = \text{MIN}$		1	2*		1	2	V
$V_{T-}$	Negative-going threshold voltage, B input	$V_{CC} = \text{MIN}$	0.7*	0.9		0.8	0.9		V
$V_{IK}$		$V_{CC} = \text{MIN}$ , $I_I = -18 \text{ mA}$			-1.5			-1.5	V
$V_{OH}$		$V_{CC} = \text{MIN}$ , $I_{OH} = -400 \mu\text{A}$	2.5	3.4		2.7	3.4		V
$V_{OL}$		$V_{CC} = \text{MIN}$	$I_{OL} = 4 \text{ mA}$		0.25	0.4	0.25	0.4	V
			$I_{OL} = 8 \text{ mA}$				0.35	0.5	
$I_I$		$V_{CC} = \text{MAX}$ , $V_I = 7 \text{ V}$			0.1			0.1	mA
$I_{IH}$		$V_{CC} = \text{MAX}$ , $V_I = 2.7 \text{ V}$			20			20	$\mu\text{A}$
$I_{IL}$	A input	$V_{CC} = \text{MAX}$ , $V_I = 0.4 \text{ V}$			-0.4			-0.4	mA
	$\overline{\text{CLR}}$ , B input				-0.8			-0.8	
$I_{OS}^{\S}$		$V_{CC} = \text{MAX}$	-20		-100	-20		-100	mA
$I_{CC}$	Quiescent	$V_{CC} = \text{MAX}$		4.7	11		4.7	11	mA
	Triggered			19	27*		19	27	

\* On products compliant to MIL-PRF-38535, this parameter is not production tested.

† For conditions shown as MIN or MAX, use the appropriate value specified under recommended operating conditions.

‡ All typical values are at  $V_{CC} = 5 \text{ V}$ ,  $T_A = 25^\circ\text{C}$ .

§ Not more than one output should be shorted at a time, and the duration of the short circuit should not exceed one second.

timing requirements over recommended ranges of supply voltage and operating free-air temperature

			SN54LS221		SN74LS221		UNIT
			MIN	MAX	MIN	MAX	
$t_w$	Pulse duration	A or B	50		50		ns
		$\overline{\text{CLR}}$	40		40		
$t_{su}$	Setup time, inactive state¶	$\overline{\text{CLR}}$	15		15		ns
$R_{ext}$	External timing resistance		1.4*	70*	1.4	100	$k\Omega$
$C_{ext}$	External timing capacitance		0*	1000*	0	1000	$\mu\text{F}$
	Output duty cycle	$R_T = 2 \text{ k}\Omega$		50%		50%	
		$R_T = \text{MAX } R_{ext}$		90%		90%	

\* On products compliant to MIL-PRF-38535, this parameter is not production tested.

¶ Inactive-state setup time also is referred to as recovery time.



**SN54221, SN54LS221, SN74221, SN74LS221**  
**DUAL MONOSTABLE MULTIVIBRATORS**  
**WITH SCHMITT-TRIGGER INPUTS**

SDLS213B – DECEMBER 1983 – REVISED NOVEMBER 2004

**switching characteristics  $V_{CC} = 5\text{ V}$ ,  $R_L = 2\text{ k}\Omega$ ,  $T_A = 25^\circ\text{C}$  (see Figures 1 and 2)**

PARAMETER	FROM (INPUT)	TO (OUTPUT)	TEST CONDITIONS	SN54LS221			SN74LS221			UNIT	
				MIN	TYP	MAX	MIN	TYP	MAX		
$t_{PLH}$	A	Q	$C_{ext} = 80\text{ pF}$ , $R_{ext} = 2\text{ k}\Omega$	45	70		45	70	ns		
	B			35	55		35	55			
$t_{PHL}$	A	$\overline{Q}$		50	80		50	80			
	B			40	65		40	65			
$t_{PHL}$	$\overline{CLR}$	Q		$C_{ext} = 80\text{ pF}$ , $R_{ext} = 2\text{ k}\Omega$	35	55		35		55	ns
$t_{PLH}$		$\overline{Q}$			44	65		44		65	
$t_w$	A or B	Q or $\overline{Q}$	$C_{ext} = 80\text{ pF}$ , $R_{ext} = 2\text{ k}\Omega$	70	120	150	70	120	150	ns	
			$C_{ext} = 0$ , $R_{ext} = 2\text{ k}\Omega$	20	47	70	20	47	70		
			$C_{ext} = 100\text{ pF}$ , $R_{ext} = 10\text{ k}\Omega$	670	740	810	670	740	810		
			$C_{ext} = 1\text{ }\mu\text{F}$ , $R_{ext} = 10\text{ k}\Omega$	6*	6.9	7.5*	6	6.9	7.5		ms

\* On products compliant to MIL-PRF-38535, this parameter is not production tested.

**SN54221, SN54LS221, SN74221, SN74LS221**  
**DUAL MONOSTABLE MULTIVIBRATORS**  
**WITH SCHMITT-TRIGGER INPUTS**

SDLS213B – DECEMBER 1983 – REVISED NOVEMBER 2004

**PARAMETER MEASUREMENT INFORMATION**

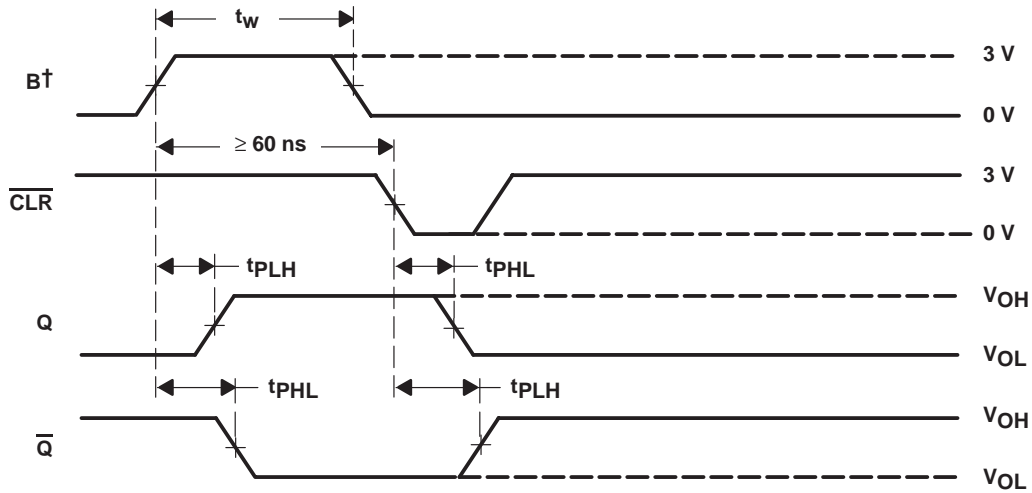

**CONDITION 1: TRIGGER FROM B, THEN  $\overline{CLR}$**

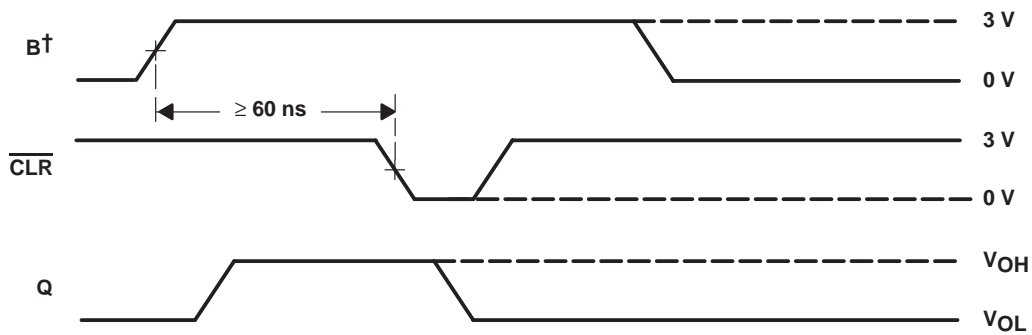

**CONDITION 2: TRIGGER FROM B, THEN  $\overline{CLR}$**

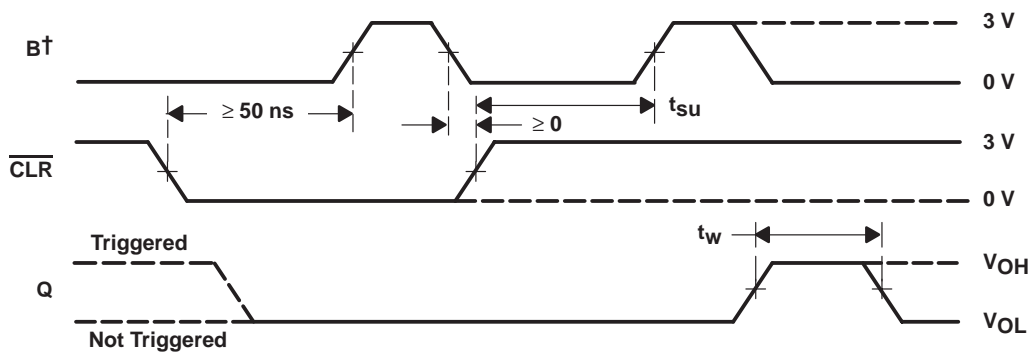

**CONDITION 3:  $\overline{CLR}$  OVERRIDING B, THEN TRIGGER FROM B**

† A is low.

**Figure 1. Switching Characteristics**



SN54221, SN54LS221, SN74221, SN74LS221  
 DUAL MONOSTABLE MULTIVIBRATORS  
 WITH SCHMITT-TRIGGER INPUTS

SDLS213B – DECEMBER 1983 – REVISED NOVEMBER 2004

PARAMETER MEASUREMENT INFORMATION

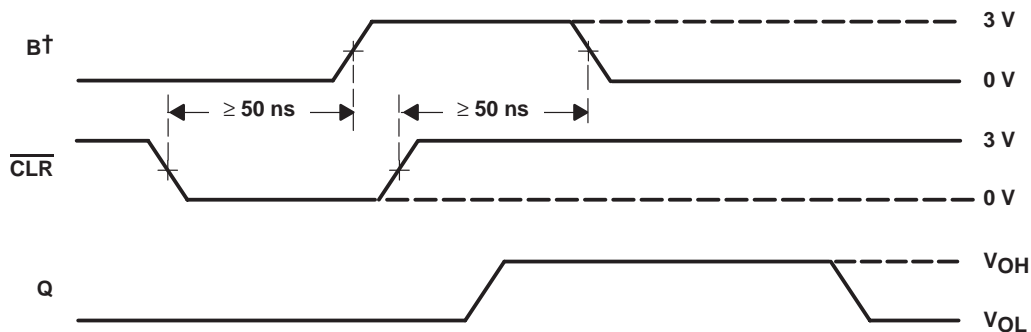

CONDITION 4: TRIGGERING FROM POSITIVE TRANSITION OF  $\overline{\text{CLR}}$

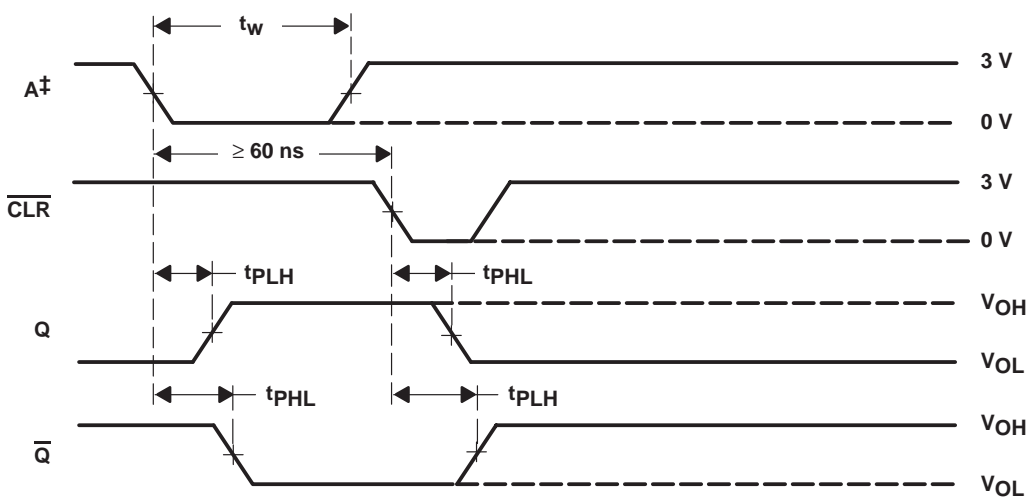

CONDITION 5: TRIGGER FROM A, THEN  $\overline{\text{CLR}}$

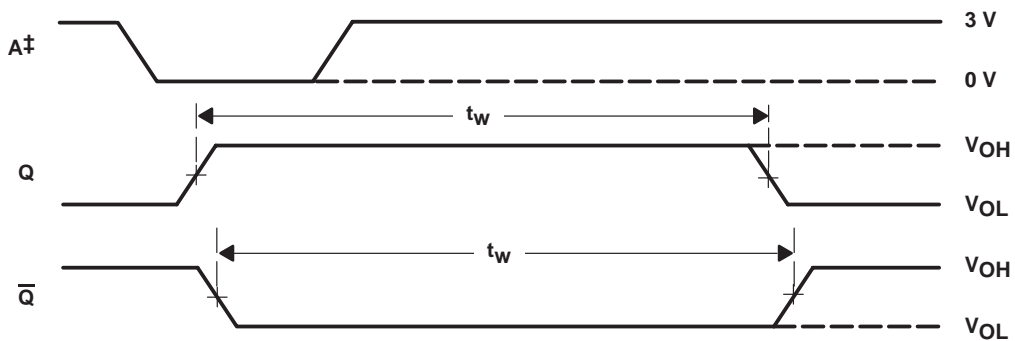

CONDITION 6: TRIGGER FROM A

† A is low.

‡ B and  $\overline{\text{CLR}}$  are high.

NOTES: A. Input pulses are supplied by generators having the following characteristics:  $\text{PRR} \leq 1 \text{ MHz}$ ,  $Z_O \approx 50\Omega$ ; for SN54/74221,  $t_r \leq 7 \text{ ns}$ ,  $t_f \leq 7 \text{ ns}$ , for SN54/74LS221,  $t_r \leq 15 \text{ ns}$ ,  $t_f \leq 6 \text{ ns}$ .

B. All measurements are made between the 1.5-V points of the indicated transitions for the SN54/74221 or between the 1.3-V points for the SN54/74LS221.

Figure 1. Switching Characteristics (Continued)



# SN54221, SN54LS221, SN74221, SN74LS221 DUAL MONOSTABLE MULTIVIBRATORS WITH SCHMITT-TRIGGER INPUTS

SDLS213B – DECEMBER 1983 – REVISED NOVEMBER 2004

## PARAMETER MEASUREMENT INFORMATION

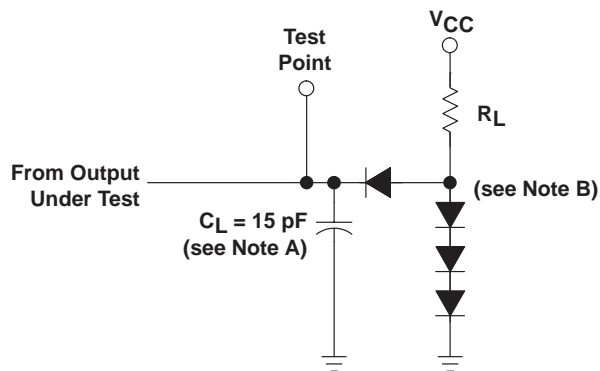

LOAD CIRCUIT FOR  
BI-STATE  
TOTEM-POLE OUTPUTS

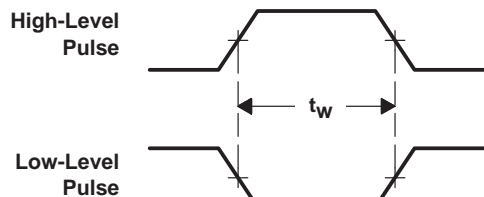

VOLTAGE WAVEFORMS  
PULSE DURATIONS

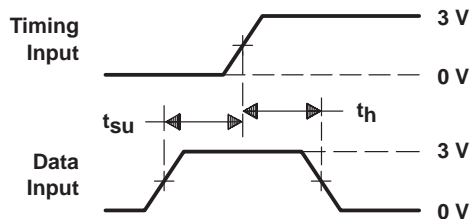

VOLTAGE WAVEFORMS  
SETUP AND HOLD TIMES

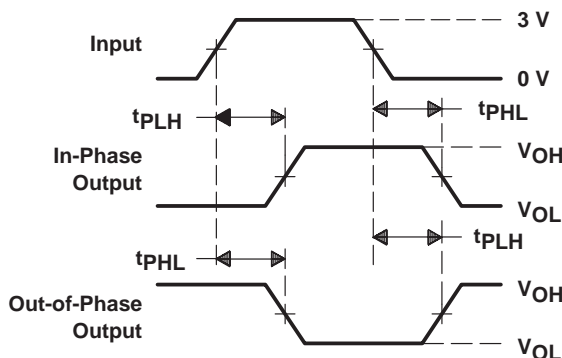

VOLTAGE WAVEFORMS  
PROPAGATION DELAY TIMES

- NOTES: A.  $C_L$  includes probe and jig capacitance.  
 B. All diodes are 1N3064 or equivalent.  
 C. In the examples above, the phase relationships between inputs and outputs have been chosen arbitrarily.  
 D. All input pulses are supplied by generators having the following characteristics:  $PRR \leq 1$  MHz,  $Z_O \approx 50 \Omega$  and, for SN54/74221,  $t_r \leq 7$  ns,  $t_f \leq 7$  ns, for SN54/74LS221,  $t_r \leq 15$  ns,  $t_f \leq 6$  ns.  
 E. All measurements are made between the 1.5-V points of the indicated transitions for the SN54/74221 or between the 1.3-V points for the SN54/74LS221.

Figure 2. Load Circuits and Voltage Waveforms

SN54221, SN54LS221, SN74221, SN74LS221  
 DUAL MONOSTABLE MULTIVIBRATORS  
 WITH SCHMITT-TRIGGER INPUTS

SDLS213B – DECEMBER 1983 – REVISED NOVEMBER 2004

TYPICAL CHARACTERISTICS (SN54/74221 ONLY)†

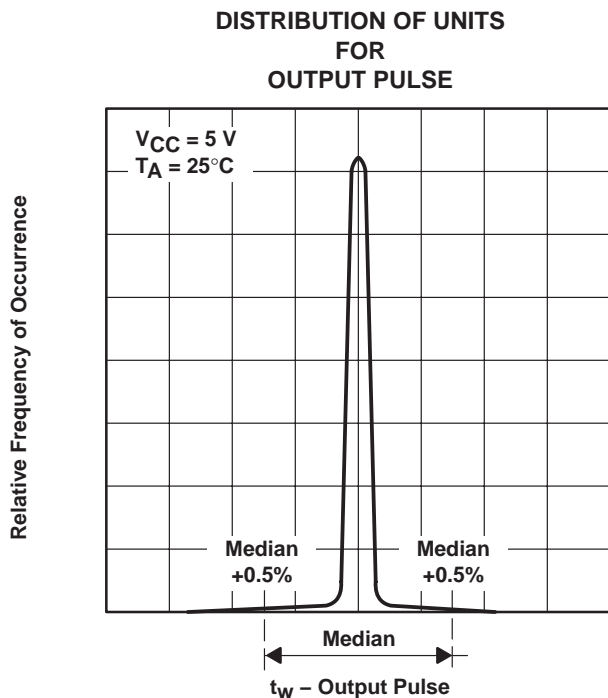

Figure 3

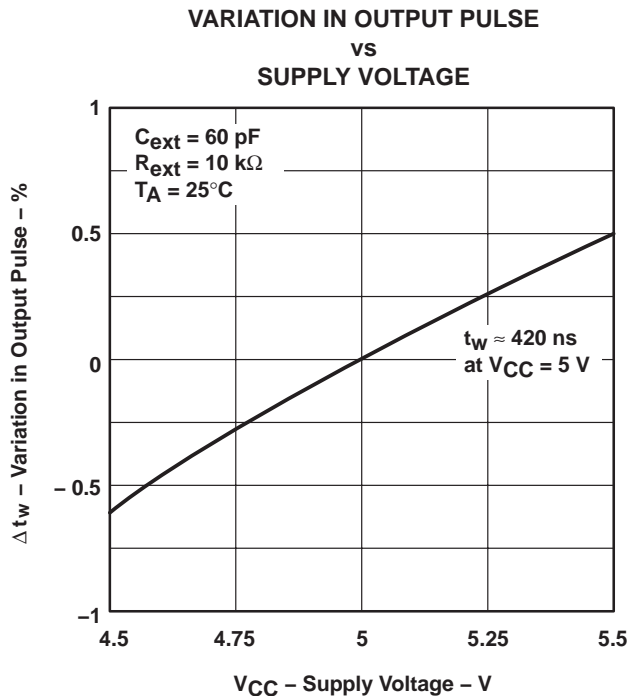

Figure 4

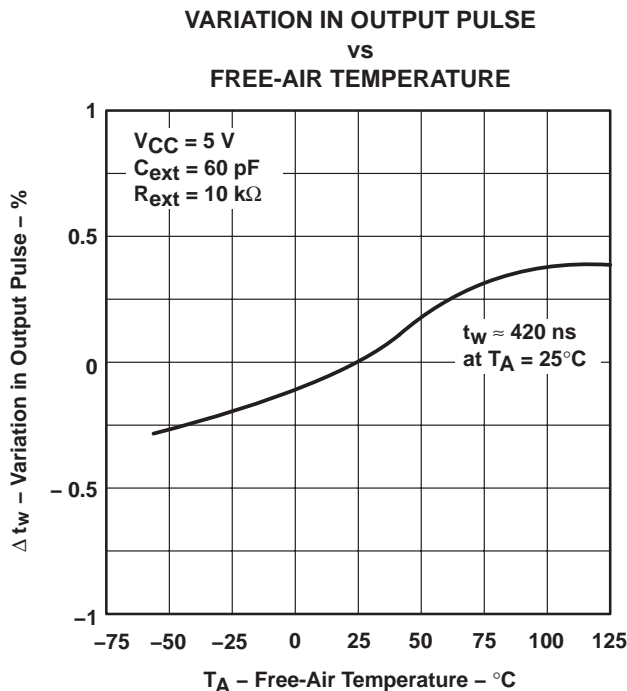

Figure 5

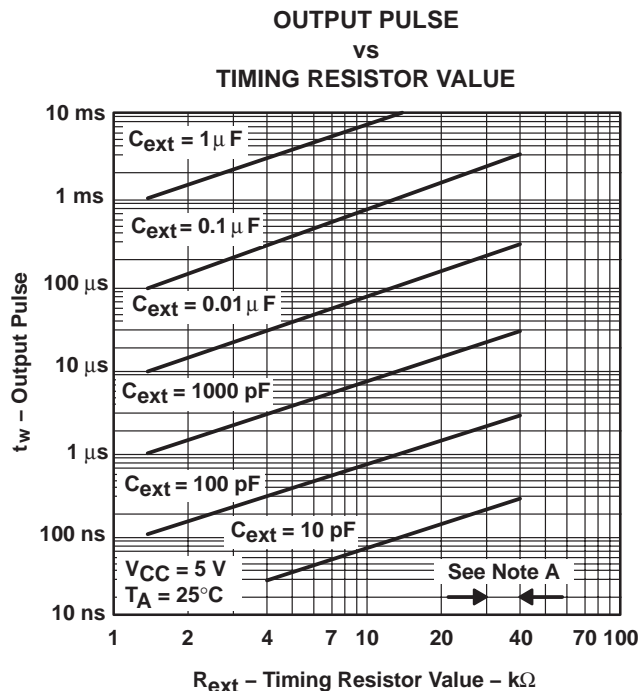

Figure 6

† Data for temperatures below 0°C and above 70°C, and for supply voltages below 4.75 V and above 5.25 V are applicable for the SN54221 only.  
 NOTE A: These values of resistance exceed the maximum recommended for use over the full military temperature range of the SN54221.

**PACKAGING INFORMATION**

Orderable part number	Status (1)	Material type (2)	Package   Pins	Package qty   Carrier	RoHS (3)	Lead finish/ Ball material (4)	MSL rating/ Peak reflow (5)	Op temp (°C)	Part marking (6)
<a href="#">5962-8771101EA</a>	Active	Production	CDIP (J)   16	25   TUBE	No	SNPB	N/A for Pkg Type	-55 to 125	5962-8771101EA SNJ54221J
<a href="#">76042012A</a>	Active	Production	LCCC (FK)   20	55   TUBE	No	SNPB	N/A for Pkg Type	-55 to 125	76042012A SNJ54LS 221FK
<a href="#">7604201EA</a>	Active	Production	CDIP (J)   16	25   TUBE	No	SNPB	N/A for Pkg Type	-55 to 125	7604201EA SNJ54LS221J
<a href="#">7604201FA</a>	Active	Production	CFP (W)   16	25   TUBE	No	SNPB	N/A for Pkg Type	-55 to 125	7604201FA SNJ54LS221W
<a href="#">JM38510/31402B2A</a>	Active	Production	LCCC (FK)   20	55   TUBE	No	SNPB	N/A for Pkg Type	-55 to 125	JM38510/ 31402B2A
JM38510/31402B2A.A	Active	Production	LCCC (FK)   20	55   TUBE	No	SNPB	N/A for Pkg Type	-55 to 125	JM38510/ 31402B2A
<a href="#">JM38510/31402BEA</a>	Active	Production	CDIP (J)   16	25   TUBE	No	SNPB	N/A for Pkg Type	-55 to 125	JM38510/ 31402BEA
JM38510/31402BEA.A	Active	Production	CDIP (J)   16	25   TUBE	No	SNPB	N/A for Pkg Type	-55 to 125	JM38510/ 31402BEA
<a href="#">JM38510/31402BFA</a>	Active	Production	CFP (W)   16	25   TUBE	No	SNPB	N/A for Pkg Type	-55 to 125	JM38510/ 31402BFA
JM38510/31402BFA.A	Active	Production	CFP (W)   16	25   TUBE	No	SNPB	N/A for Pkg Type	-55 to 125	JM38510/ 31402BFA
<a href="#">M38510/31402B2A</a>	Active	Production	LCCC (FK)   20	55   TUBE	No	SNPB	N/A for Pkg Type	-55 to 125	JM38510/ 31402B2A
<a href="#">M38510/31402BEA</a>	Active	Production	CDIP (J)   16	25   TUBE	No	SNPB	N/A for Pkg Type	-55 to 125	JM38510/ 31402BEA
<a href="#">M38510/31402BFA</a>	Active	Production	CFP (W)   16	25   TUBE	No	SNPB	N/A for Pkg Type	-55 to 125	JM38510/ 31402BFA
<a href="#">SN54221J</a>	Active	Production	CDIP (J)   16	25   TUBE	No	SNPB	N/A for Pkg Type	-55 to 125	SN54221J
SN54221J.A	Active	Production	CDIP (J)   16	25   TUBE	No	SNPB	N/A for Pkg Type	-55 to 125	SN54221J
<a href="#">SN54LS221J</a>	Active	Production	CDIP (J)   16	25   TUBE	No	SNPB	N/A for Pkg Type	-55 to 125	SN54LS221J
SN54LS221J.A	Active	Production	CDIP (J)   16	25   TUBE	No	SNPB	N/A for Pkg Type	-55 to 125	SN54LS221J
<a href="#">SN74221N</a>	Active	Production	PDIP (N)   16	25   TUBE	Yes	NIPDAU   NIPDAU	N/A for Pkg Type	0 to 70	SN74221N
SN74221N.A	Active	Production	PDIP (N)   16	25   TUBE	Yes	NIPDAU	N/A for Pkg Type	0 to 70	SN74221N

Orderable part number	Status (1)	Material type (2)	Package   Pins	Package qty   Carrier	RoHS (3)	Lead finish/ Ball material (4)	MSL rating/ Peak reflow (5)	Op temp (°C)	Part marking (6)
SN74221NE4	Active	Production	PDIP (N)   16	25   TUBE	Yes	NIPDAU	N/A for Pkg Type	0 to 70	SN74221N
<a href="#">SN74LS221D</a>	Obsolete	Production	SOIC (D)   16	-	-	Call TI	Call TI	0 to 70	LS221
<a href="#">SN74LS221DBR</a>	Active	Production	SSOP (DB)   16	2000   LARGE T&R	Yes	NIPDAU	Level-1-260C-UNLIM	0 to 70	LS221
SN74LS221DBR.A	Active	Production	SSOP (DB)   16	2000   LARGE T&R	Yes	NIPDAU	Level-1-260C-UNLIM	0 to 70	LS221
<a href="#">SN74LS221DR</a>	Active	Production	SOIC (D)   16	2500   LARGE T&R	Yes	NIPDAU	Level-1-260C-UNLIM	0 to 70	LS221
SN74LS221DR.A	Active	Production	SOIC (D)   16	2500   LARGE T&R	Yes	NIPDAU	Level-1-260C-UNLIM	0 to 70	LS221
<a href="#">SN74LS221N</a>	Active	Production	PDIP (N)   16	25   TUBE	Yes	NIPDAU	N/A for Pkg Type	0 to 70	SN74LS221N
SN74LS221N.A	Active	Production	PDIP (N)   16	25   TUBE	Yes	NIPDAU	N/A for Pkg Type	0 to 70	SN74LS221N
SN74LS221NE4	Active	Production	PDIP (N)   16	25   TUBE	Yes	NIPDAU	N/A for Pkg Type	0 to 70	SN74LS221N
<a href="#">SN74LS221NSR</a>	Active	Production	SOP (NS)   16	2000   LARGE T&R	Yes	NIPDAU	Level-1-260C-UNLIM	0 to 70	74LS221
SN74LS221NSR.A	Active	Production	SOP (NS)   16	2000   LARGE T&R	Yes	NIPDAU	Level-1-260C-UNLIM	0 to 70	74LS221
<a href="#">SNJ54221J</a>	Active	Production	CDIP (J)   16	25   TUBE	No	SNPB	N/A for Pkg Type	-55 to 125	5962-8771101EA SNJ54221J
SNJ54221J.A	Active	Production	CDIP (J)   16	25   TUBE	No	SNPB	N/A for Pkg Type	-55 to 125	5962-8771101EA SNJ54221J
<a href="#">SNJ54LS221FK</a>	Active	Production	LCCC (FK)   20	55   TUBE	No	SNPB	N/A for Pkg Type	-55 to 125	76042012A SNJ54LS 221FK
SNJ54LS221FK.A	Active	Production	LCCC (FK)   20	55   TUBE	No	SNPB	N/A for Pkg Type	-55 to 125	76042012A SNJ54LS 221FK
<a href="#">SNJ54LS221J</a>	Active	Production	CDIP (J)   16	25   TUBE	No	SNPB	N/A for Pkg Type	-55 to 125	7604201EA SNJ54LS221J
SNJ54LS221J.A	Active	Production	CDIP (J)   16	25   TUBE	No	SNPB	N/A for Pkg Type	-55 to 125	7604201EA SNJ54LS221J
<a href="#">SNJ54LS221W</a>	Active	Production	CFP (W)   16	25   TUBE	No	SNPB	N/A for Pkg Type	-55 to 125	7604201FA SNJ54LS221W
SNJ54LS221W.A	Active	Production	CFP (W)   16	25   TUBE	No	SNPB	N/A for Pkg Type	-55 to 125	7604201FA SNJ54LS221W

<sup>(1)</sup> **Status:** For more details on status, see our [product life cycle](#).

(2) **Material type:** When designated, preproduction parts are prototypes/experimental devices, and are not yet approved or released for full production. Testing and final process, including without limitation quality assurance, reliability performance testing, and/or process qualification, may not yet be complete, and this item is subject to further changes or possible discontinuation. If available for ordering, purchases will be subject to an additional waiver at checkout, and are intended for early internal evaluation purposes only. These items are sold without warranties of any kind.

(3) **RoHS values:** Yes, No, RoHS Exempt. See the [TI RoHS Statement](#) for additional information and value definition.

(4) **Lead finish/Ball material:** Parts may have multiple material finish options. Finish options are separated by a vertical ruled line. Lead finish/Ball material values may wrap to two lines if the finish value exceeds the maximum column width.

(5) **MSL rating/Peak reflow:** The moisture sensitivity level ratings and peak solder (reflow) temperatures. In the event that a part has multiple moisture sensitivity ratings, only the lowest level per JEDEC standards is shown. Refer to the shipping label for the actual reflow temperature that will be used to mount the part to the printed circuit board.

(6) **Part marking:** There may be an additional marking, which relates to the logo, the lot trace code information, or the environmental category of the part.

Multiple part markings will be inside parentheses. Only one part marking contained in parentheses and separated by a "~" will appear on a part. If a line is indented then it is a continuation of the previous line and the two combined represent the entire part marking for that device.

**Important Information and Disclaimer:** The information provided on this page represents TI's knowledge and belief as of the date that it is provided. TI bases its knowledge and belief on information provided by third parties, and makes no representation or warranty as to the accuracy of such information. Efforts are underway to better integrate information from third parties. TI has taken and continues to take reasonable steps to provide representative and accurate information but may not have conducted destructive testing or chemical analysis on incoming materials and chemicals. TI and TI suppliers consider certain information to be proprietary, and thus CAS numbers and other limited information may not be available for release.

In no event shall TI's liability arising out of such information exceed the total purchase price of the TI part(s) at issue in this document sold by TI to Customer on an annual basis.

**OTHER QUALIFIED VERSIONS OF SN54221, SN54LS221, SN74221, SN74LS221 :**

- Catalog : [SN74221](#), [SN74LS221](#)
- Military : [SN54221](#), [SN54LS221](#)

NOTE: Qualified Version Definitions:

- Catalog - TI's standard catalog product
- Military - QML certified for Military and Defense Applications

**TAPE AND REEL INFORMATION**

**QUADRANT ASSIGNMENTS FOR PIN 1 ORIENTATION IN TAPE**



\*All dimensions are nominal

Device	Package Type	Package Drawing	Pins	SPQ	Reel Diameter (mm)	Reel Width W1 (mm)	A0 (mm)	B0 (mm)	K0 (mm)	P1 (mm)	W (mm)	Pin1 Quadrant
SN74LS221DBR	SSOP	DB	16	2000	330.0	16.4	8.35	6.6	2.4	12.0	16.0	Q1
SN74LS221DR	SOIC	D	16	2500	330.0	16.4	6.5	10.3	2.1	8.0	16.0	Q1
SN74LS221NSR	SOP	NS	16	2000	330.0	16.4	8.2	10.5	2.5	12.0	16.0	Q1

**TAPE AND REEL BOX DIMENSIONS**

\*All dimensions are nominal

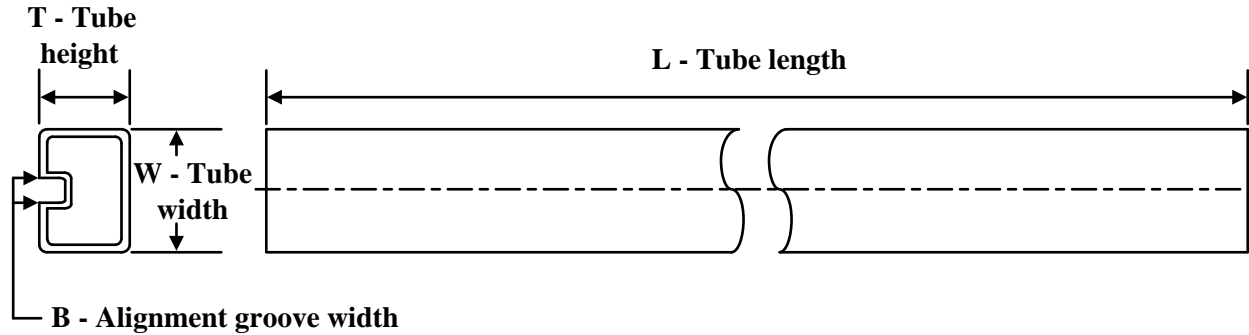
Device	Package Type	Package Drawing	Pins	SPQ	Length (mm)	Width (mm)	Height (mm)
SN74LS221DBR	SSOP	DB	16	2000	356.0	356.0	35.0
SN74LS221DR	SOIC	D	16	2500	353.0	353.0	32.0
SN74LS221NSR	SOP	NS	16	2000	356.0	356.0	35.0

**TUBE**

\*All dimensions are nominal

Device	Package Name	Package Type	Pins	SPQ	L (mm)	W (mm)	T (µm)	B (mm)
76042012A	FK	LCCC	20	55	506.98	12.06	2030	NA
7604201FA	W	CFP	16	25	506.98	26.16	6220	NA
JM38510/31402B2A	FK	LCCC	20	55	506.98	12.06	2030	NA
JM38510/31402B2A.A	FK	LCCC	20	55	506.98	12.06	2030	NA
JM38510/31402BFA	W	CFP	16	25	506.98	26.16	6220	NA
JM38510/31402BFA.A	W	CFP	16	25	506.98	26.16	6220	NA
M38510/31402B2A	FK	LCCC	20	55	506.98	12.06	2030	NA
M38510/31402BFA	W	CFP	16	25	506.98	26.16	6220	NA
SN74221N	N	PDIP	16	25	506	13.97	11230	4.32
SN74221N	N	PDIP	16	25	506	13.97	11230	4.32
SN74221N.A	N	PDIP	16	25	506	13.97	11230	4.32
SN74221N.A	N	PDIP	16	25	506	13.97	11230	4.32
SN74221NE4	N	PDIP	16	25	506	13.97	11230	4.32
SN74221NE4	N	PDIP	16	25	506	13.97	11230	4.32
SN74LS221N	N	PDIP	16	25	506	13.97	11230	4.32
SN74LS221N	N	PDIP	16	25	506	13.97	11230	4.32
SN74LS221N.A	N	PDIP	16	25	506	13.97	11230	4.32
SN74LS221N.A	N	PDIP	16	25	506	13.97	11230	4.32
SN74LS221NE4	N	PDIP	16	25	506	13.97	11230	4.32
SN74LS221NE4	N	PDIP	16	25	506	13.97	11230	4.32
SNJ54LS221FK	FK	LCCC	20	55	506.98	12.06	2030	NA
SNJ54LS221FK.A	FK	LCCC	20	55	506.98	12.06	2030	NA
SNJ54LS221W	W	CFP	16	25	506.98	26.16	6220	NA
SNJ54LS221W.A	W	CFP	16	25	506.98	26.16	6220	NA

D (R-PDSO-G16)

PLASTIC SMALL OUTLINE



- NOTES:
- A. All linear dimensions are in inches (millimeters).
  - B. This drawing is subject to change without notice.
  - C. Body length does not include mold flash, protrusions, or gate burrs. Mold flash, protrusions, or gate burrs shall not exceed 0.006 (0,15) each side.
  - D. Body width does not include interlead flash. Interlead flash shall not exceed 0.017 (0,43) each side.
  - E. Reference JEDEC MS-012 variation AC.

# DB0016A



# PACKAGE OUTLINE

## SSOP - 2 mm max height

SMALL OUTLINE PACKAGE



4220763/A 05/2022

### NOTES:

1. All linear dimensions are in millimeters. Any dimensions in parenthesis are for reference only. Dimensioning and tolerancing per ASME Y14.5M.
2. This drawing is subject to change without notice.
3. This dimension does not include mold flash, protrusions, or gate burrs. Mold flash, protrusions, or gate burrs shall not exceed 0.15 mm per side.
4. Reference JEDEC registration MO-150.

# EXAMPLE BOARD LAYOUT

DB0016A

SSOP - 2 mm max height

SMALL OUTLINE PACKAGE



LAND PATTERN EXAMPLE  
EXPOSED METAL SHOWN  
SCALE: 10X



4220763/A 05/2022

NOTES: (continued)

- 5. Publication IPC-7351 may have alternate designs.
- 6. Solder mask tolerances between and around signal pads can vary based on board fabrication site.

# EXAMPLE STENCIL DESIGN

DB0016A

SSOP - 2 mm max height

SMALL OUTLINE PACKAGE



SOLDER PASTE EXAMPLE  
BASED ON 0.125 mm THICK STENCIL  
SCALE: 10X

4220763/A 05/2022

NOTES: (continued)

7. Laser cutting apertures with trapezoidal walls and rounded corners may offer better paste release. IPC-7525 may have alternate design recommendations.
8. Board assembly site may have different recommendations for stencil design.

# MECHANICAL DATA

NS (R-PDSO-G\*\*)

PLASTIC SMALL-OUTLINE PACKAGE

14-PINS SHOWN



- NOTES:
- A. All linear dimensions are in millimeters.
  - B. This drawing is subject to change without notice.
  - C. Body dimensions do not include mold flash or protrusion, not to exceed 0,15.

W (R-GDFP-F16)

CERAMIC DUAL FLATPACK



- NOTES:
- A. All linear dimensions are in inches (millimeters).
  - B. This drawing is subject to change without notice.
  - C. This package can be hermetically sealed with a ceramic lid using glass frit.
  - D. Index point is provided on cap for terminal identification only.
  - E. Falls within MIL STD 1835 GDFP2-F16

## GENERIC PACKAGE VIEW

**FK 20**

**LCCC - 2.03 mm max height**

8.89 x 8.89, 1.27 mm pitch

LEADLESS CERAMIC CHIP CARRIER

This image is a representation of the package family, actual package may vary.  
Refer to the product data sheet for package details.

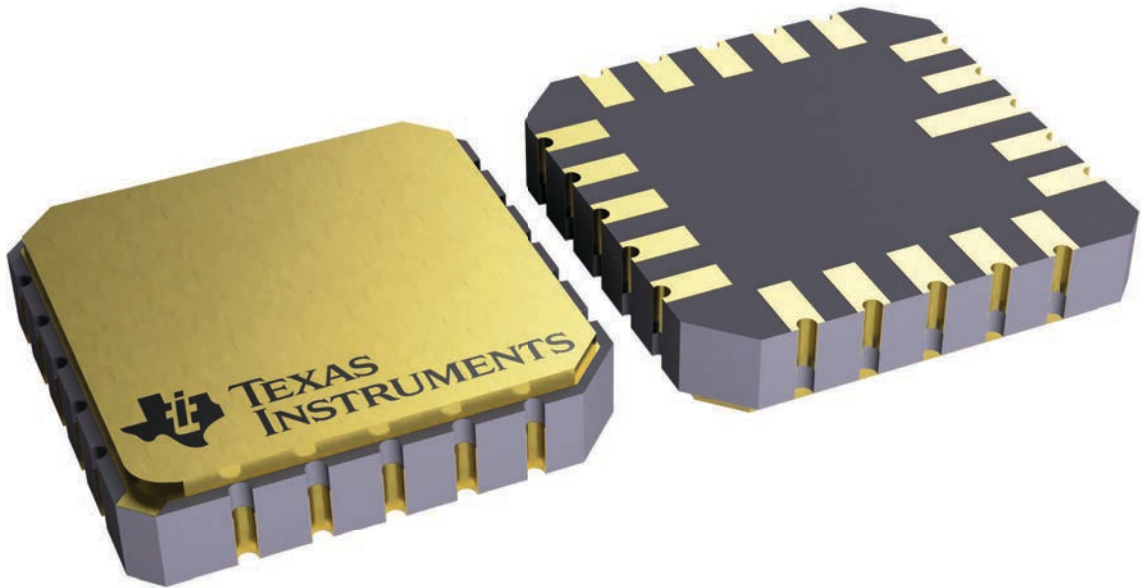

4229370VA\

J (R-GDIP-T\*\*)

14 LEADS SHOWN

CERAMIC DUAL IN-LINE PACKAGE



DIM \ PINS **	14	16	18	20
A	0.300 (7,62) BSC	0.300 (7,62) BSC	0.300 (7,62) BSC	0.300 (7,62) BSC
B MAX	0.785 (19,94)	.840 (21,34)	0.960 (24,38)	1.060 (26,92)
B MIN	—	—	—	—
C MAX	0.300 (7,62)	0.300 (7,62)	0.310 (7,87)	0.300 (7,62)
C MIN	0.245 (6,22)	0.245 (6,22)	0.220 (5,59)	0.245 (6,22)



4040083/F 03/03

- NOTES:
- All linear dimensions are in inches (millimeters).
  - This drawing is subject to change without notice.
  - This package is hermetically sealed with a ceramic lid using glass frit.
  - Index point is provided on cap for terminal identification only on press ceramic glass frit seal only.
  - Falls within MIL STD 1835 GDIP1-T14, GDIP1-T16, GDIP1-T18 and GDIP1-T20.

N (R-PDIP-T\*\*)

PLASTIC DUAL-IN-LINE PACKAGE

16 PINS SHOWN

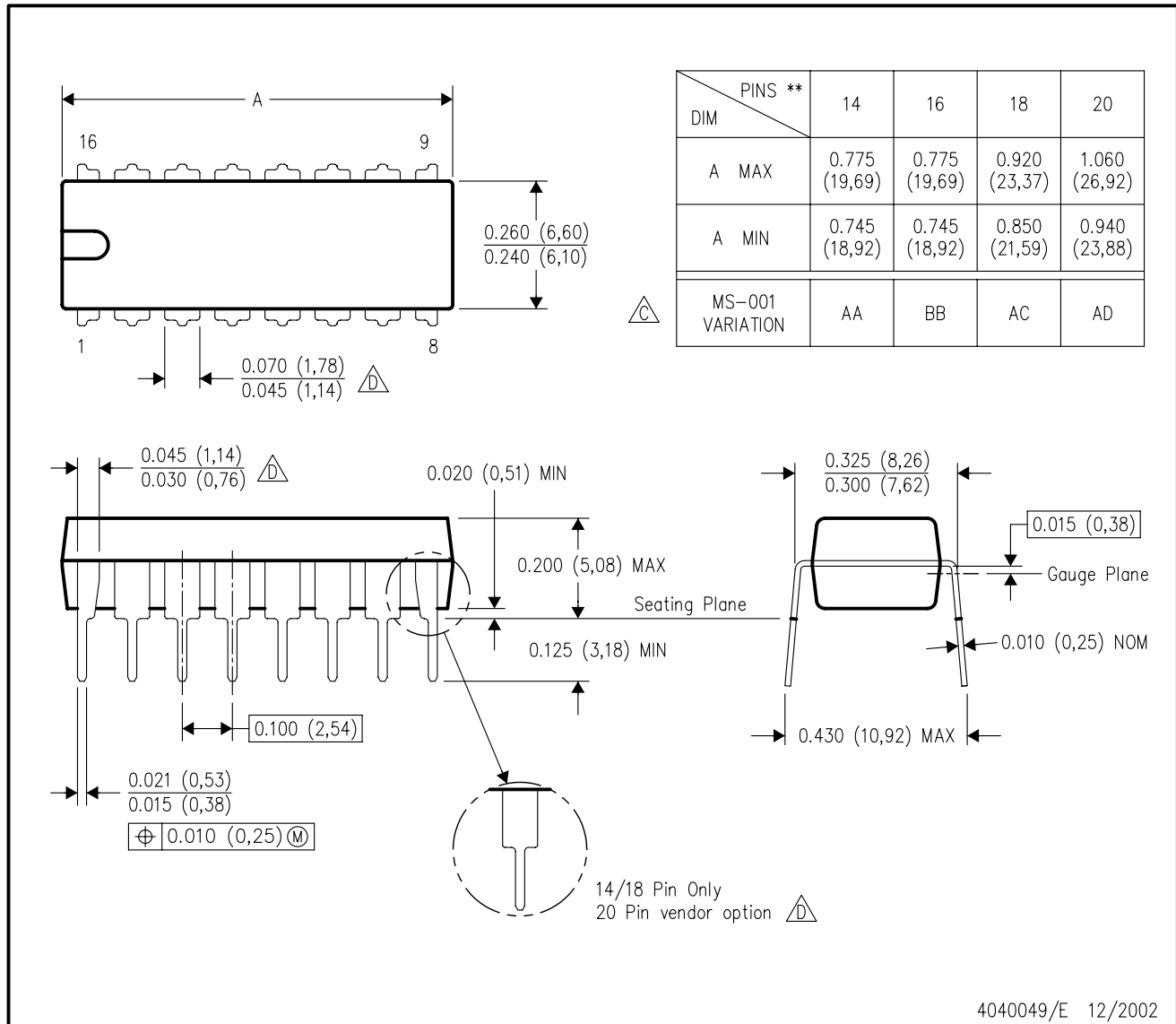

- NOTES:
- A. All linear dimensions are in inches (millimeters).
  - B. This drawing is subject to change without notice.
  - Falls within JEDEC MS-001, except 18 and 20 pin minimum body length (Dim A).
  - The 20 pin end lead shoulder width is a vendor option, either half or full width.



# PACKAGE OUTLINE

## NS0016A

### SOP - 2.00 mm max height

SOP

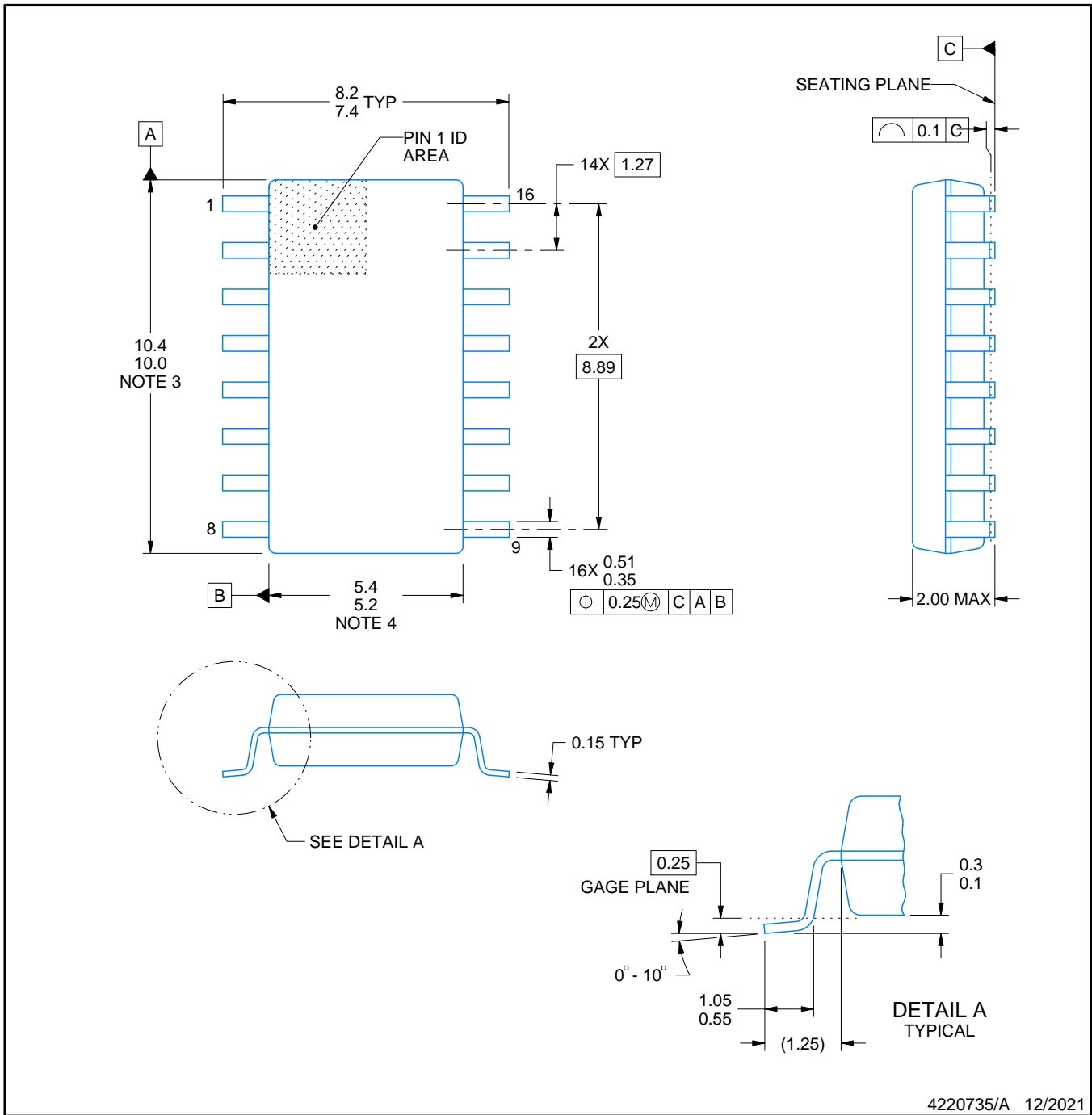

4220735/A 12/2021

#### NOTES:

1. All linear dimensions are in millimeters. Dimensions in parenthesis are for reference only. Dimensioning and tolerancing per ASME Y14.5M.
2. This drawing is subject to change without notice.
3. This dimension does not include mold flash, protrusions, or gate burrs. Mold flash, protrusions, or gate burrs shall not exceed 0.15 mm, per side.
4. This dimension does not include interlead flash. Interlead flash shall not exceed 0.25 mm, per side.

# EXAMPLE BOARD LAYOUT

NS0016A

SOP - 2.00 mm max height

SOP



4220735/A 12/2021

NOTES: (continued)

5. Publication IPC-7351 may have alternate designs.

6. Solder mask tolerances between and around signal pads can vary based on board fabrication site.

# EXAMPLE STENCIL DESIGN

NS0016A

SOP - 2.00 mm max height

SOP



SOLDER PASTE EXAMPLE  
BASED ON 0.125 mm THICK STENCIL  
SCALE:7X

4220735/A 12/2021

NOTES: (continued)

7. Laser cutting apertures with trapezoidal walls and rounded corners may offer better paste release. IPC-7525 may have alternate design recommendations.
8. Board assembly site may have different recommendations for stencil design.

## IMPORTANT NOTICE AND DISCLAIMER

TI PROVIDES TECHNICAL AND RELIABILITY DATA (INCLUDING DATA SHEETS), DESIGN RESOURCES (INCLUDING REFERENCE DESIGNS), APPLICATION OR OTHER DESIGN ADVICE, WEB TOOLS, SAFETY INFORMATION, AND OTHER RESOURCES "AS IS" AND WITH ALL FAULTS, AND DISCLAIMS ALL WARRANTIES, EXPRESS AND IMPLIED, INCLUDING WITHOUT LIMITATION ANY IMPLIED WARRANTIES OF MERCHANTABILITY, FITNESS FOR A PARTICULAR PURPOSE OR NON-INFRINGEMENT OF THIRD PARTY INTELLECTUAL PROPERTY RIGHTS.

These resources are intended for skilled developers designing with TI products. You are solely responsible for (1) selecting the appropriate TI products for your application, (2) designing, validating and testing your application, and (3) ensuring your application meets applicable standards, and any other safety, security, regulatory or other requirements.

These resources are subject to change without notice. TI grants you permission to use these resources only for development of an application that uses the TI products described in the resource. Other reproduction and display of these resources is prohibited. No license is granted to any other TI intellectual property right or to any third party intellectual property right. TI disclaims responsibility for, and you will fully indemnify TI and its representatives against, any claims, damages, costs, losses, and liabilities arising out of your use of these resources.

TI's products are provided subject to [TI's Terms of Sale](#) or other applicable terms available either on [ti.com](#) or provided in conjunction with such TI products. TI's provision of these resources does not expand or otherwise alter TI's applicable warranties or warranty disclaimers for TI products.

TI objects to and rejects any additional or different terms you may have proposed.

Mailing Address: Texas Instruments, Post Office Box 655303, Dallas, Texas 75265

Copyright © 2025, Texas Instruments Incorporated