

DRV8163-Q1 Automotive 65V Half-Bridge Driver with Integrated Current Sense and Diagnostics

1 Features

- AEC-Q100 qualified for automotive applications:
 - Temperature grade 1: -40°C to $+125^{\circ}\text{C}$, T_A
- [Functional Safety-Capable](#)
 - Documentation available to aid functional safety system design
- **4.5V to 65V (70V abs. max)** operating range
- MOSFET ON resistance (HS + LS): **43mΩ**
- Maximum output current = **40A**
- 2 Interface options - **HW or SPI**
- PWM frequency operation up to 100kHz with automatic dead time assertion
- Configurable slew rate and spread spectrum clocking for low electromagnetic interference (EMI)
- Integrated current sense (eliminates shunt resistor)
- Proportional load current output on **IPROPI**
- Die temperature monitoring on IPROPI (SPI only)
- Configurable current regulation
- Protection and diagnostic features with configurable fault reaction (latched or retry)
 - Load diagnostics in both the off-state and on-state to detect open load and short circuit
 - Voltage monitoring on supply (VM)
 - Over current protection
 - Over temperature warning (SPI only)
 - Over temperature protection
 - **Powered off Braking**
 - Fault indication on nFAULT pin
- Supports 1.8V, 3.3V, 5V logic inputs
- Low sleep current - 7μA typical at 25°C
- [Device family comparison table](#)

2 Applications

- [24V and 48V Automotive Body Systems](#)
- [Automotive brushed DC motors, Solenoids](#)
- [Door modules , mirror modules, wiper modules and seat modules](#)
- [Trunk lift, Window lift](#)
- [Steering column, Sunroof shade](#)
- [Electric Vehicles, Truck, Bus and other Commercial Vehicles](#)

3 Description

The DRV8163-Q1 is a wide-voltage, high-power fully integrated half-bridge driver for 24V and 48V automotive applications. Designed in a BiCMOS high-power process technology node, this device in a power package offers excellent power handling and

thermal capability while providing compact package size, ease of layout, EMI control, accurate current sense, robustness, and diagnostic capability.

The device integrates a N-channel half-bridge, charge pump, high-side current sensing with regulation, current proportional output, and protection circuitry. The integrated sensing uses a current mirror, removing the need for shunt resistors, saving board area, and reducing system cost. A low-power sleep mode is provided to achieve low quiescent current.

The device offers voltage monitoring and load diagnostics, as well as protection features against overcurrent and overtemperature. Fault conditions are indicated on the nFAULT pin. It is available in two variants: HW interface and SPI interface. The SPI variant offers more flexibility in device configuration and fault observability.

Device Information ¹

PART NUMBER	INTERFACE	PACKAGE SIZE ²
DRV8163HQVAKRQ1	HW	VQFN-HR (15) (3.5mm x 6mm)
DRV8163SQVAKRQ1	SPI	VQFN-HR (15) (3.5mm x 6mm)

- (1) See the orderable addendum at the end of the data sheet.
- (2) The package size (length x width) is a nominal value and includes pins, where applicable.

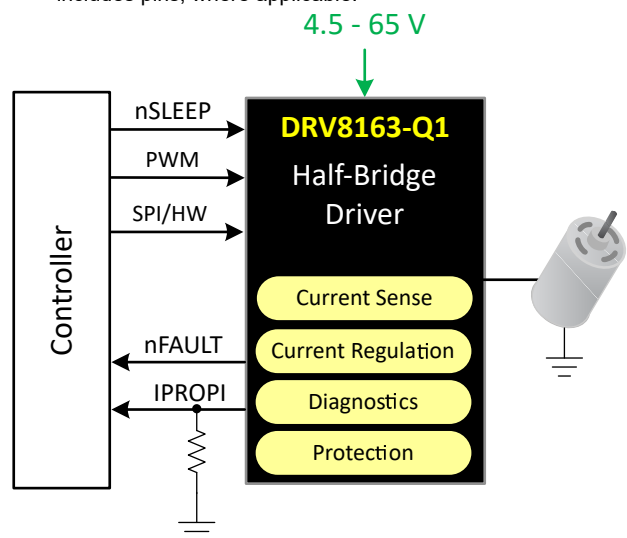

Simplified Schematic

ADVANCE INFORMATION

Table of Contents

1 Features	1	7.3 Feature Description.....	23
2 Applications	1	8 Register Map - SPI Variant Only	45
3 Description	1	8.1 User Registers.....	45
4 Device Comparison	3	9 Application and Implementation	50
5 Pin Configuration and Functions	4	9.1 Application Information.....	50
5.1 HW Variant.....	4	9.2 Typical Application.....	51
5.2 SPI Variant.....	5	10 Device and Documentation Support	53
6 Specifications	7	10.1 Device Support.....	53
6.1 Absolute Maximum Ratings.....	7	10.2 Documentation Support.....	53
6.2 ESD Ratings.....	7	10.3 Receiving Notification of Documentation Updates..	53
6.3 Recommended Operating Conditions.....	7	10.4 Support Resources.....	53
6.4 Thermal Information.....	8	10.5 Trademarks.....	53
6.5 Electrical Characteristics.....	8	10.6 Electrostatic Discharge Caution.....	53
6.6 Switching Waveforms.....	14	10.7 Glossary.....	53
7 Detailed Description	21	11 Mechanical, Packaging, and Orderable Information	53
7.1 Overview.....	21		
7.2 Functional Block Diagram.....	21		

4 Device Comparison

Table 4-1 summarizes the R_{ON} and package differences between devices in the DRV8X6X-Q1 family.

Table 4-1. Device Comparison

PART NUMBER ⁽¹⁾	Configuration	(LS + HS) R_{ON}	$I_{OUT\ MAX}$	PACKAGE	BODY SIZE	Interface
DRV8262-Q1	1 or 2 H-bridge	50m Ω or 100m Ω	16A or 8A	HTSSOP (44)	14 mm X 6.1 mm	HW
DRV8962-Q1	4 Half-bridge	100m Ω	8A	HTSSOP (44)	14 mm X 6.1 mm	HW
DRV8263-Q1	1 H-bridge	85m Ω	29A	VQFN-HR (15)	3.5 mm X 6 mm	HW, SPI
DRV8163-Q1	1 Half-bridge	43m Ω	40A	VQFN-HR (15)	3.5 mm X 6 mm	HW, SPI

(1) This is the product datasheet for the DRV8163-Q1. Please reference other device variant data sheets for additional information.

Table 4-2 summarizes the feature differences between the SPI and HW interface variants in the DRV8163-Q1. In general, the SPI variant offers more configurability, bridge control options, diagnostic feedback, and additional features.

Table 4-2. SPI Variant vs HW Variant Comparison

FUNCTION	HW Variant	SPI Variant
Bridge control	Pin only	Individual pin "and/or" register bit with pin status indication (Refer Register Pin control)
Clear fault command	Reset pulse on nSLEEP pin	SPI CLR_FAULT command
Over current protection (OCP)	Fixed at the highest setting	4 choices for thresholds, 4 choices for filter time
ITRIP regulation	5 levels with disable & fixed TOFF time	7 levels with disable & indication, with programmable TOFF time
Individual fault reaction configuration between retry or latched behavior	Not supported, either all latched or all retry	Supported
Detailed fault logging and device status feedback	Not supported, nFAULT pin monitoring necessary	Supported, nFAULT pin monitoring optional
VM over voltage	Not supported	Supported
On-state (Active) diagnostics	Not supported	Supported for high-side loads
Spread spectrum clocking (SSC)	Not supported	Supported
Overtemperature warning	Not supported	Supported
Die Temperature monitor	Not supported	Supported

Table 4-3. Differentiating between devices in the family

Device	Package Symbolization	DEVICE_ID Register
DRV8262-Q1	8262	Not applicable
DRV8962-Q1	8962	Not applicable
DRV8263H-Q1	8263H	Not applicable
DRV8163H-Q1	8163H	Not applicable
DRV8263S-Q1	8263S	0 x 34
DRV8163S-Q1	8163S	0 x 3C

5 Pin Configuration and Functions

5.1 HW Variant

Figure 5-1.

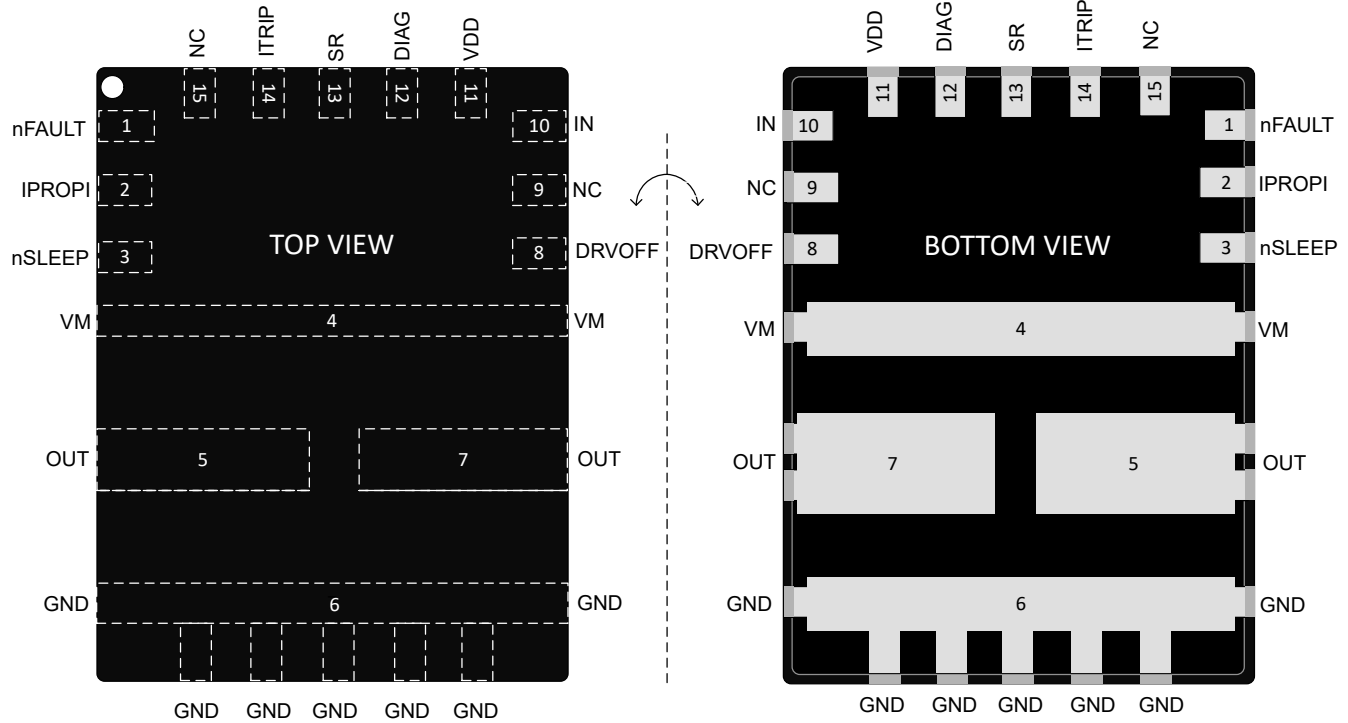

Figure 5-2. DRV8163H-Q1 in VQFN-HR(15) Package

Table 5-1. Pin Functions

PIN		TYPE ⁽¹⁾	DESCRIPTION
NO.	NAME		
1	nFAULT	OD	Fault indication to the controller.
2	IPROPI	I/O	Driver load current analog feedback. For details, refer to IPROPI in the Device Configuration section .
3	nSLEEP	I	Controller input pin for SLEEP . For details, see the Bridge Control section .
4	VM	P	Power supply. This pin is the motor supply voltage. Bypass this pin to GND with a 0.1µF ceramic capacitor and a bulk capacitor.
5, 7	OUT	P	Half-bridge output. Connect these pins together to the motor or load.
6	GND	G	Ground pin
8	DRVOFF	I	Controller input pin for bridge Hi-Z. For details, see the Bridge Control section .
9	NC	-	No connect.
10	IN	I	Controller input pin for bridge operation. For details, see the Bridge Control section .
11	VDD	P	Logic power supply to the device.
12	DIAG	I	Device configuration pin for load type indication and fault reaction configuration. For details, refer to DIAG in the Device Configuration section .
13	SR	I	Device configuration pin for Slew Rate control . For details, refer to Slew Rate in the Device Configuration section .
14	ITRIP	I	Device configuration pin for ITRIP level for high-side current limiting. For details, refer to ITRIP in the Device Configuration section .

ADVANCE INFORMATION

Table 5-1. Pin Functions (continued)

PIN		TYPE ⁽¹⁾	DESCRIPTION
NO.	NAME		
15	NC	-	No connect.

(1) I = input, O = output, I/O = input/output, G = ground, P = power, OD = open-drain output, PP = push-pull output

5.2 SPI Variant

Figure 5-3.

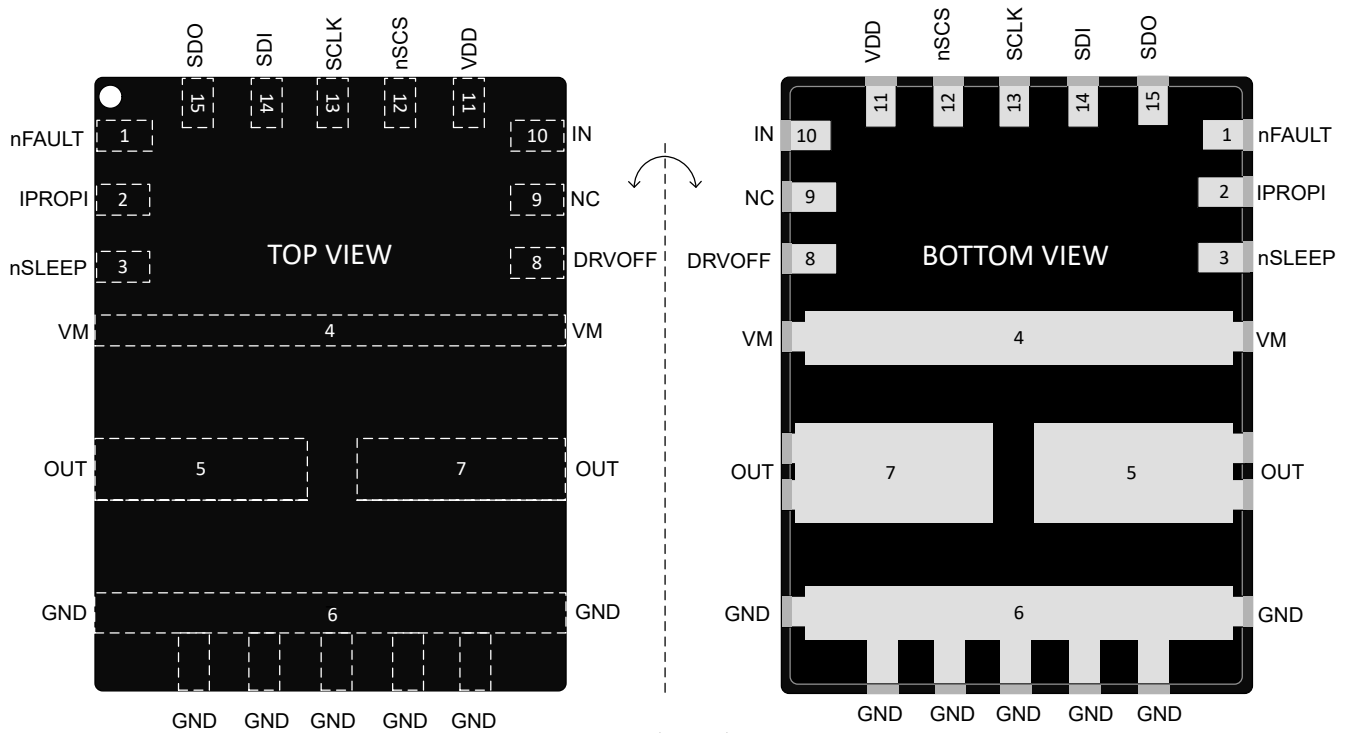

Figure 5-4. DRV8163S-Q1 in VQFN-HR (15) Package

Table 5-2. Pin Functions

PIN		TYPE ⁽¹⁾	DESCRIPTION
NO.	NAME		
1	nFAULT	OD	Fault indication to the controller.
2	IPROPI	I/O	Multi-purpose pin. Provides driver load current analog feedback or analog voltage proportional to die temperature. For details, refer to IPROPI in the Device Configuration section .
3	nSLEEP	I	Controller input pin for SLEEP . For details, see the Bridge Control section .
4	VM	P	Power supply. This pin is the motor supply voltage. Bypass this pin to GND with a 0.1µF ceramic capacitor and a bulk capacitor.
5, 7	OUT	P	Half-bridge output. Connect these pins together to the motor or load.
6	GND	G	Ground pin
8	DRVOFF	I	Controller input pin for bridge Hi-Z. For details, see the Bridge Control section .
9	NC	-	No connect.
10	IN	I	Controller input pin for bridge operation. For details, see the Bridge Control section .
11	VDD	P	Logic power supply to the device.

Table 5-2. Pin Functions (continued)

PIN		TYPE ⁽¹⁾	DESCRIPTION
NO.	NAME		
12	nSCS	I	SPI - Chip Select. An active low on this pin enables the serial interface communication.
13	SCLK	I	SPI - Serial Clock input.
14	SDI	I	SPI - Serial Data Input. Data is captured at the falling edge of SCLK.
15	SDO	PP	SPI - Serial Data Output. Data is updated at the rising edge of SCLK.

(1) I = input, O = output, I/O = input/output, G = ground, P = power, OD = open-drain output, PP = push-pull output

6 Specifications

6.1 Absolute Maximum Ratings

Over operating temperature range (unless otherwise noted)⁽¹⁾

		MIN	MAX	UNIT
Power supply pin voltage	VM	-0.3 ⁽³⁾	70	V
Power supply transient voltage ramp	VM		2	V/μs
Logic supply voltage	VDD	-0.3	5.75	V
Logic supply transient voltage ramp	VDD		5	V/μs
Continuous Output pin voltage	OUT	-1	V _{VM} + 1	V
Transient 100 ns Output pin voltage	OUT	-3	V _{VM} + 3	V
Output pin current	OUT	Internally limited ⁽²⁾		A
DRVOFF, nSLEEP pin voltage	DRVOFF, nSLEEP	-0.3	70	V
Logic I/O voltage	IN, nFAULT	-0.3	5.75	V
HW variant - Configuration pins voltage	ITRIP, SR, DIAG	-0.3	5.75	V
Analog feedback pin voltage	IPROPI	-0.3	5.75	V
SPI I/O voltage - SPI variant	SDI, SDO, nSCS, SCLK	-0.3	5.75	V
Ambient temperature, T _A		-40	125	°C
Junction temperature, T _J		-40	150	°C
Storage temperature, T _{stg}		-65	150	°C

- (1) Stresses beyond those listed under *Absolute Maximum Rating* may cause permanent damage to the device. These are stress ratings only, which do not imply functional operation of the device at these or any other conditions beyond those indicated under *Recommended Operating Conditions*. Exposure to absolute-maximum-rated conditions for extended periods may affect device reliability.
- (2) Limited by the over current and over temperature protection functions of the device
- (3) With external component support, short duration violation of this limit can be tolerated during ISO 7637 transient pulse testing

6.2 ESD Ratings

			VALUE	UNIT
V _(ESD)	Electrostatic discharge	Human body model (HBM), per AEC Q100-002 ⁽¹⁾	VM, OUT, GND	V
		HBM ESD Classification Level 2	All other pins	
		Charged device model (CDM), per AEC Q100-011	Corner pins	
		CDM ESD Classification Level C4B	Other pins	

- (1) AEC Q100-002 indicates that HBM stressing shall be in accordance with the ANSI/ESDA/JEDEC JS-001 specification.

6.3 Recommended Operating Conditions

over operating temperature range (unless otherwise noted)

			MIN	MAX	UNIT
V _{VM}	Power supply voltage	VM	4.5	65	V
V _{VDD}	Logic supply voltage	VDD	3	5.5	V
V _{LOGIC}	Logic I/O pin voltage	IN, nSLEEP, DRVOFF, nFAULT	0	5.5	V
f _{PWM}	PWM frequency	IN	0	100	kHz
V _{CONFIG}	HW variant - Configuration pin voltage	ITRIP, SR, DIAG	0	5.5	V
V _{IPROPI}	Analog feedback voltage	IPROPI	0	5.5	V

over operating temperature range (unless otherwise noted)

			MIN	MAX	UNIT
V _{SPI_IOS}	SPI pin voltage	SDI, SDO, nSCS, SCLK	0	V _{VDD} + 0.5	V
T _A	Operating ambient temperature		-40	125	°C
T _J	Operating junction temperature		-40	150	°C

6.4 Thermal Information

Refer [Transient thermal impedance](#) table for application related use case.

THERMAL METRIC ⁽¹⁾		VQFN-HR package	UNIT
R _{θJA}	Junction-to-ambient thermal resistance	31.5	°C/W
R _{θJC(top)}	Junction-to-case(top) thermal resistance	TBD	°C/W
R _{θJB}	Junction-to-board thermal resistance	TBD	°C/W
Ψ _{JT}	Junction-to-top characterization parameter	TBD	°C/W
Ψ _{JB}	Junction-to-board characterization parameter	TBD	°C/W
R _{θJC(bot)}	Junction-to-case(bottom) thermal resistance	TBD	°C/W

- (1) For more information about traditional and new thermal metrics, see the [Semiconductor and IC Package Thermal Metrics](#) application report.

6.4.1 Transient Thermal Impedance & Current Capability

Information based on thermal simulations

Table 6-1. Transient Thermal Impedance (R_{θJA}) and Current Capability

PART NUMBER	R _{θJA} [°C/W] ⁽¹⁾			Current [A] ⁽²⁾				
				without PWM ⁽³⁾			with PWM ⁽⁴⁾	
	0.1sec	1sec	DC	0.1sec	1sec	DC	1sec	DC
DRV8163-Q1	3.96	8.38	31.5	TBD	TBD	TBD	TBD	TBD

- (1) Based on thermal simulations using 40mm x 40mm x 1.6mm 4-layer PCB – 2oz Cu on top and bottom layers, 1oz Cu on internal planes with 0.3 mm thermal via drill diameter, 0.025mm Cu plating, 1 minimum mm via pitch.
(2) Estimated transient current capability at 85 °C ambient temperature for junction temperature rise to 150°C
(3) Only conduction losses (I²R) are considered
(4) Switching loss roughly estimated by the following equation:

$$P_{SW} = V_{VM} \times I_{Load} \times f_{PWM} \times V_{VM}/SR, \text{ where } V_{VM} = 48V, f_{PWM} = 20KHz, SR = 220V/\mu s \quad (1)$$

6.5 Electrical Characteristics

Typical values are at T_A = 25°C and V_{VM} = 48 V. All limits are over recommended operating conditions, unless otherwise noted.

PARAMETER	TEST CONDITIONS	MIN	TYP	MAX	UNIT
POWER SUPPLIES (VM, VDD)					
I _{VDD}	VDD current in ACTIVE state	Die temperature readout disabled	2	3.5	mA
I _{VMS}	VM current in STANDBY state	V _{VM} = 48 V, Drivers Hi-Z, Die temperature readout disabled	1	1.8	
I _{VMQ}	VM current in SLEEP state	V _{VM} = 48 V, POB disabled, V _{nSLEEP} = 0 V or V _{VDD} < V _{POR_FALL}	7	30	μA
I _{VMQ_POB}	VM current in SLEEP state with POB	V _{VM} = 48 V, POB enabled, V _{nSLEEP} = 0 V	8	35	μA

Typical values are at $T_A = 25^\circ\text{C}$ and $V_{VM} = 48\text{ V}$. All limits are over recommended operating conditions, unless otherwise noted.

PARAMETER		TEST CONDITIONS	MIN	TYP	MAX	UNIT
I_{VDDQ_POB}	VDD current in SLEEP state with POB	$V_{VM} = 48\text{ V}$, POB enabled, $V_{nSLEEP} = 0\text{ V}$		7.5	14	μA
t_{RESET}	RESET pulse filter time	Reset signal on nSLEEP, HW variant	5		35	μs
t_{SLEEP}	Sleep command filter time	Sleep signal on nSLEEP, HW variant	40		120	μs
t_{SLEEP_SPI}	Sleep command filter time	Sleep signal on nSLEEP, SPI variant	5		20	μs
t_{WAKEUP}	Wake-up command filter time	Wake-up signal on nSLEEP		6		μs
t_{COM}	Time for communication to be available after wake-up or power-up through VM or VDD pin	Wake-up signal on nSLEEP pin or power cycle ($V_{VM} > V_{POR_RISE}$ or $V_{VDD} > V_{POR_RISE}$)			200	μs
t_{READY}	Time for driver ready to be driven after wake-up through nSLEEP or power-up through VM or VDD	Wake-up signal on nSLEEP pin or power cycle ($V_{VM} > V_{POR_RISE}$ or $V_{VDD} > V_{POR_RISE}$)			1.2	ms
LOGIC-LEVEL INPUTS (nSLEEP, DRVOFF, IN, nSCS, SDI, SCLK)						
V_{IL}	Input logic-low voltage	All pins	0		0.6	V
V_{IH}	Input logic-high voltage	All pins	1.5		5.5	V
V_{HYS}	Input logic hysteresis	All pins (except nSLEEP)		100		mV
V_{HYS_nSLEEP}	nSLEEP logic hysteresis			180		mV
R_{PU}	Internal pull-up resistance on DRVOFF and nSCS	Measured at min V_{IH} level	150		450	k Ω
R_{PD}	Internal pull-down resistance on IN, SDI, SCLK	Measured at max V_{IL} level	150		450	k Ω
R_{PD_nSLEEP}	Internal pull-down resistance on nSLEEP	Measured at max V_{IL} level	160		400	k Ω
TRI-LEVEL INPUT (MODE)						
R_{LVL1}	Level 1	Connect to GND			10	Ω
R_{LVL2}	Level 2	+/- 10% resistor to GND	8	16	24	k Ω
R_{LVL3}	Level 3	Hi-Z (no connect)	249			k Ω
QUAD-LEVEL INPUT (SR)						
R_{LVL1}	Level 1	Connect to GND			10	Ω
R_{LVL2}	Level 2	+/- 10% resistor to GND	8	16	24	k Ω
R_{LVL3}	Level 3	+/- 10% resistor to GND	45	75	110	k Ω
R_{LVL4}	Level 4	Hi-Z (no connect)	249			k Ω
SIX-LEVEL INPUTS (ITRIP, DIAG)						
R_{LVL1}	Level 1	Connect to GND			10	Ω
R_{LVL2}	Level 2	+/- 10% resistor to GND	8	9	10	k Ω
R_{LVL3}	Level 3	+/- 10% resistor to GND	22	24	26	k Ω
R_{LVL4}	Level 4	+/- 10% resistor to GND	45	48	51	k Ω
R_{LVL5}	Level 5	+/- 10% resistor to GND	90	100	110	k Ω

Typical values are at $T_A = 25^\circ\text{C}$ and $V_{VM} = 48\text{ V}$. All limits are over recommended operating conditions, unless otherwise noted.

PARAMETER		TEST CONDITIONS	MIN	TYP	MAX	UNIT
R_{LVL6}	Level 6	Hi-Z (no connect)	249			k Ω
PUSH-PULL OUTPUT (SDO)						
V_{OL_SDO}	Output logic-low voltage	0.5 mA sink		0.1	0.2	V
V_{OH_SDO}	Output logic-high voltage	0.5 mA source, $V_{VDD} = 5\text{ V}$	4.7	4.9		V
I_{SDO}	SDO Leakage Current	$V_{VM} > 6\text{ V}$	-2		2	μA
CONTROL OUTPUTS (nFAULT)						
V_{OL}	Output logic-low voltage	$I_O = 5\text{ mA}$			0.3	V
I_{OH}	Output logic-high leakage		-1		1	μA
DRIVER OUTPUTS (OUT)						
R_{HS_ON}	High-side FET on resistance	$T_J = 25^\circ\text{C}$, $I_O = -6\text{ A}$		21	25	m Ω
		$T_J = 150^\circ\text{C}$, $I_O = -6\text{ A}$		35	42	m Ω
R_{LS_ON}	Low-side FET on resistance	$T_J = 25^\circ\text{C}$, $I_O = 6\text{ A}$		22	26	m Ω
		$T_J = 150^\circ\text{C}$, $I_O = 6\text{ A}$		36	43	m Ω
V_{SD}	Body diode forward voltage	$I_O = \pm 6\text{ A}$ (both directions)	0.4	0.8	1.2	V
I_{Hi-Z}	OUT leakage current to GND in SLEEP state	$V_{OUTx} = V_{VM} = 48\text{ V}$			140	μA
Switching Parameters with High-Side Recirculation						
SR_{LS}	Output voltage rise/fall slew rate, 10% - 90% (rise), 90% - 10% (fall), $V_{VM} = 48\text{ V}$, $I_O = 6\text{ A}$	SR = 00b or LVL1	180	220	260	V/ μs
		SR = 01b or LVL2	90	110	130	V/ μs
		SR = 10b or LVL3	40	50	60	V/ μs
		SR = 11b or LVL4	16	20	24	V/ μs
t_{PD_LSOFF}	Propagation delay during output voltage rise, $I_O = 6\text{ A}$	SR = 00b or 01b or LVL1 or LVL2		0.24		μs
		SR = 10b or 11b or LVL3 or LVL4		0.28		μs
t_{PD_LSON}	Propagation delay during output voltage fall, $I_O = 6\text{ A}$	SR = 00b or 01b or LVL1 or LVL2		0.32		μs
		SR = 10b or 11b or LVL3 or LVL4		0.46		μs
t_{DEAD_LSOFF}	Dead time during output voltage rise, $I_O = 6\text{ A}$	SR = 00b or 01b or LVL1 or LVL2		0.28		μs
		SR = 10b or LVL3		0.36		μs
		SR = 11b or LVL4		0.65		μs
t_{DEAD_LSON}	Dead time during output voltage fall, $I_O = 6\text{ A}$	SR = 00b or 01b or LVL1 or LVL2		0.68		μs
		SR = 10b or LVL3		0.75		μs
		SR = 11b or LVL4		0.82		μs
Switching Parameters with Low-Side Recirculation						
SR_{HS}	Output voltage rise/fall slew rate, 10% - 90% (rise), 90% - 10% (fall), $V_{VM} = 48\text{ V}$, $I_O = 6\text{ A}$	SR = 00b or LVL1	180	220	260	V/ μs
		SR = 01b or LVL2	90	110	130	V/ μs
		SR = 10b or LVL3	40	50	60	V/ μs
		SR = 11b or LVL4	16	20	24	V/ μs

Typical values are at $T_A = 25^\circ\text{C}$ and $V_{VM} = 48\text{ V}$. All limits are over recommended operating conditions, unless otherwise noted.

PARAMETER		TEST CONDITIONS	MIN	TYP	MAX	UNIT
t_{PD_HSON}	Propagation delay during output voltage rise, $I_O = 6\text{ A}$	SR = 00b or 01b or LVL1 or LVL2		0.24		μs
		SR = 10b or 11b or LVL3 or LVL4		0.28		μs
t_{PD_HSOFF}	Propagation delay during output voltage fall, $I_O = 6\text{ A}$	SR = 00b or 01b or LVL1 or LVL2		0.32		μs
		SR = 10b or LVL3		0.45		μs
		SR = 11b or LVL4		0.53		μs
t_{DEAD_HSON}	Dead time during output voltage rise, $I_O = 6\text{ A}$	SR = 00b or LVL1		0.68		μs
		SR = 01b or LVL2		0.8		μs
		SR = 10b or LVL3		1.07		μs
		SR = 11b or LVL4		1.8		μs
t_{DEAD_HSOFF}	Dead time during output voltage fall, $I_O = 6\text{ A}$	All slew rates		0.11		μs
t_{BLANK}	Current regulation blanking time (Valid for only for LS recirculation)	TBLK = 0b. Only choice for HW.		0.8		μs
		TBLK = 1b		1.8		μs
IPROPI & ITRIP Regulation						
A_{IPROPI}	Current mirror gain	$I_{OUT} > 2\text{ A}$	190	202	215	$\mu\text{A/A}$
A_{ERR}	Current mirror scaling error	$I_{OUT} > 2\text{ A}$	-5		7	%
		$0.5\text{ A} < I_{OUT} \leq 2\text{ A}$	-8		8	
		$0.2\text{ A} < I_{OUT} \leq 0.5\text{ A}$	-15		15	
A_{ERR_M}	Current matching between the two half-bridges	$I_{OUT} > 2\text{ A}$	-3		+3	%
V_{IPROPI_LIM}	Internal clamping voltage on IPROPI		3.4		5.5	V
V_{ITRIP_LVL}	Voltage limit on V_{IPROPI} to trigger TOFF cycle for ITRIP regulation	S_ITRIP = 001b or LVL2	1.08	1.2	1.3	V
		S_ITRIP = 010b (SPI only)	1.31	1.44	1.55	V
		S_ITRIP = 011b (SPI only)	1.53	1.67	1.81	V
		S_ITRIP = 100b or LVL3	1.83	2	2.16	V
		S_ITRIP = 101b or LVL4	2.14	2.34	2.52	V
		S_ITRIP = 110b or LVL5	2.44	2.67	2.88	V
		S_ITRIP = 111b or LVL6	2.74	3	3.24	V
t_{OFF}	ITRIP regulation off-time	TOFF = 00b	9	20	35	μs
		TOFF = 01b. Only choice for HW.	15	30	45	
		TOFF = 10b	20	40	60	
		TOFF = 11b	25	50	70	
PROTECTION CIRCUITS						
V_{VMOV_POB}	VM over voltage threshold while rising during POB		60		69	V
V_{VMOV}	VM over voltage threshold while rising	OVSEL = 0b (SPI only)	59.5		64.5	V

Typical values are at $T_A = 25^\circ\text{C}$ and $V_{VM} = 48\text{ V}$. All limits are over recommended operating conditions, unless otherwise noted.

PARAMETER		TEST CONDITIONS	MIN	TYP	MAX	UNIT
V_{VMOV_HYS}	VM over voltage hysteresis			0.7		V
t_{VMOV}	VM over voltage deglitch time		4	12	19	μs
V_{VMUV}	VM UVLO lockout	VM falling	4.1	4.25	4.4	V
		VM rising	4.15	4.3	4.45	
V_{VMUV_HYST}	VM UVLO hysteresis	Rising to falling threshold		100		mV
t_{VMUV}	VM UVLO deglitch time		3	12	20	μs
V_{POR_FALL}	VM or VDD voltage at which device goes into POR				3.2	V
V_{POR_RISE}	VM or VDD voltage at which device comes out of POR				3.5	V
I_{OCP}	Overcurrent protection threshold	OCP_SEL = 11b	40		56	A
		OCP_SEL = 10b	29		42	A
		OCP_SEL = 01b	20		27	A
		OCP_SEL = 00b (default), only choice for HW	10		14	A
I_{OCP_POB}	Overcurrent protection threshold with POB enabled		29		40	A
t_{OCP}	Overcurrent protection deglitch time	TOCP = 0b	0.5	1	1.5	μs
		TOCP = 1b, only choice for HW	0.6	2	3.5	μs
t_{RETRY}	Overcurrent protection retry time	Fault reaction set to RETRY	2.6	5	6.7	ms
t_{CLEAR}	Fault free operation time to auto-clear from over current event	Fault reaction set to RETRY	70		140	μs
T_{TSD}	Thermal shutdown	Die temperature T_J	155	170	185	$^\circ\text{C}$
T_{HYS_TSD}	Thermal shutdown hysteresis	Die temperature T_J		20		$^\circ\text{C}$
t_{TSD}	Thermal shutdown deglitch time		7	12	18	μs
t_{CLEAR_TSD}	Fault free operation time to auto-clear from over temperature event	Fault reaction set to RETRY	3.6	5	6.4	ms
T_{OTW}	Over Temperature Warning Threshold	Die temperature T_J , OTW_SEL = 0b	125	140	155	$^\circ\text{C}$
		Die temperature T_J , OTW_SEL = 1b	105	120	135	$^\circ\text{C}$
T_{HYS_OTW}	Over Temperature Warning hysteresis	Die temperature T_J		20		$^\circ\text{C}$
t_{OTW}	Over Temperature Warning deglitch time		7	12	18	μs
T_{DIE}	Die Temperature Measurement Range	Die temperature T_J	-40		185	$^\circ\text{C}$
I_{IPROPI_DIE}	IPROPI Current Range for Die Temperature Measurement		0.5		1.5	mA
T_{DIE_ACC}	Die Temperature Measurement Accuracy	Die temperature T_J	-10		10	%

Typical values are at $T_A = 25^\circ\text{C}$ and $V_{VM} = 48\text{ V}$. All limits are over recommended operating conditions, unless otherwise noted.

PARAMETER		TEST CONDITIONS	MIN	TYP	MAX	UNIT
V_{POB_TH}	Powered off braking threshold			580		mV
t_{OCP_POB}	Overcurrent protection deglitch time in POB		1.2	2	2.8	μs
t_{POB_ON}	Powered off braking turn-on time			20		μs
t_{POB_RETRY}	Powered off braking retry time			180		μs
R_{S_GND}	Resistance on OUT to GND that will be detected as short				1.5	k Ω
R_{S_VM}	Resistance on OUT to VM that will be detected as short				3	k Ω
R_{OPEN_FB}	Resistance between OUTx that will be detected as open		0.5			k Ω
R_{OPEN_LS}	Resistance on OUT to GND that will be detected as open	Valid for low-side load	1.5			k Ω
R_{OPEN_HS}	Resistance on OUT to VM that will be detected as open	Valid for high-side load, $V_{VM} = 48\text{ V}$	30			k Ω
V_{OLP_REFL}	OLP Comparator Reference Low	$V_{VM} > 5\text{ V}$		2.2		V
R_{OLP_PU}	Internal pull-up resistance on OUT to internal 5V during OLP	$V_{OUTx} = V_{OLP_REFH} + 0.1\text{ V}$		1		k Ω
R_{OLP_PD}	Internal pull-down resistance on OUT to GND during OLP	$V_{OUTx} = V_{OLP_REFL} - 0.1\text{ V}$		1		k Ω
I_{PD_OLA}	Internal sink current on OUTx to GND during dead-time in high-side recirculation	SR = 00b or LVL1	10		24	mA
		SR = 01b or LVL2	5		12	
		SR = 10b or LVL3	2.3		6	
		SR = 11b or LVL4	0.8		2.6	
V_{OLA_REF}	Comparator Reference with respect to VM used for OLA			0.28		V

ADVANCE INFORMATION

6.5.1 SPI Timing Requirements

		MIN	TYP	MAX	UNIT
t_{SCLK}	SCLK minimum period ⁽¹⁾	110			ns
t_{SCLKH}	SCLK minimum high time	50			ns
t_{SCLKL}	SCLK minimum low time	50			ns
t_{HI_nSCS}	nSCS minimum high time	600			ns
t_{SU_nSCS}	nSCS input setup time	25			ns
t_{H_nSCS}	nSCS input hold time	25			ns
t_{SU_SDI}	SDI input data setup time	25			ns
t_{H_SDI}	SDI input data hold time	25			ns
t_{EN_SDO}	SDO enable delay time ⁽¹⁾			45	ns

		MIN	TYP	MAX	UNIT
t_{DIS_SDO}	SDO disable delay time ⁽¹⁾			100	ns

(1) SDO delay times are valid only with SDO external load of 5 pF. With a 20 pF load on SDO, there is an additional delay on SDO, which results in a 25% increase in SCLK minimum time, limiting the SCLK to a maximum of 8 MHz.

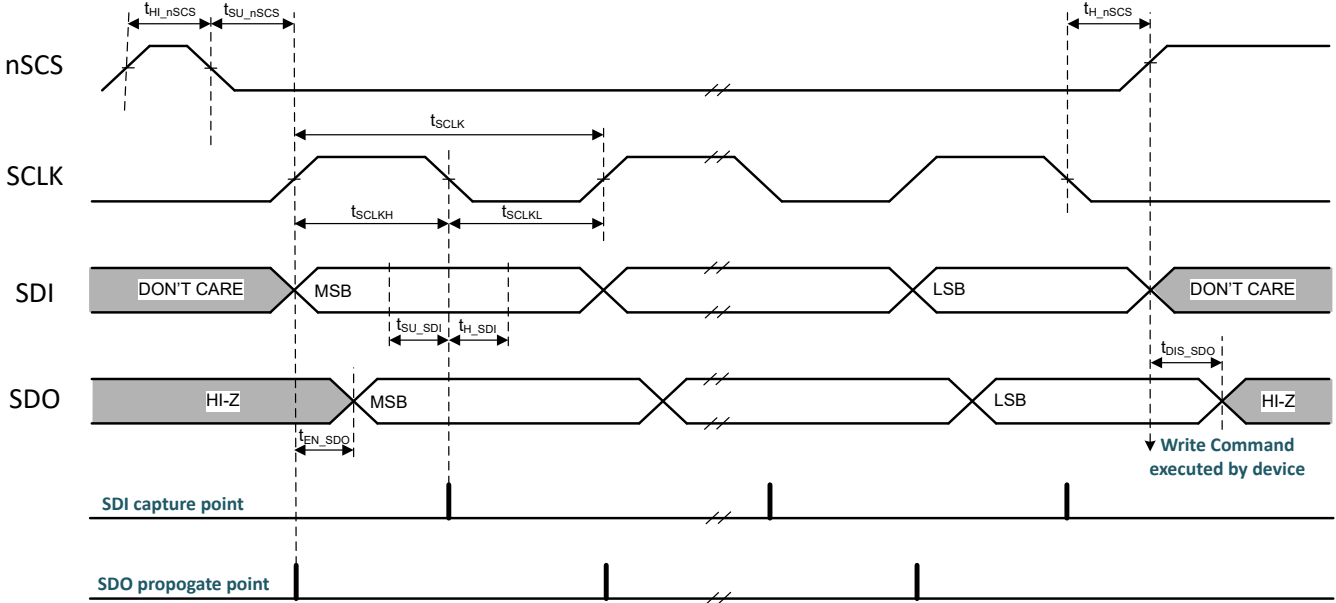

Figure 6-1. SPI Peripheral-Mode Timing Definition

6.6 Switching Waveforms

6.6.1 Output switching transients

This section illustrates the switching transients for an inductive load due to external PWM or internal ITRIP regulation.

6.6.1.1 High-Side Recirculation

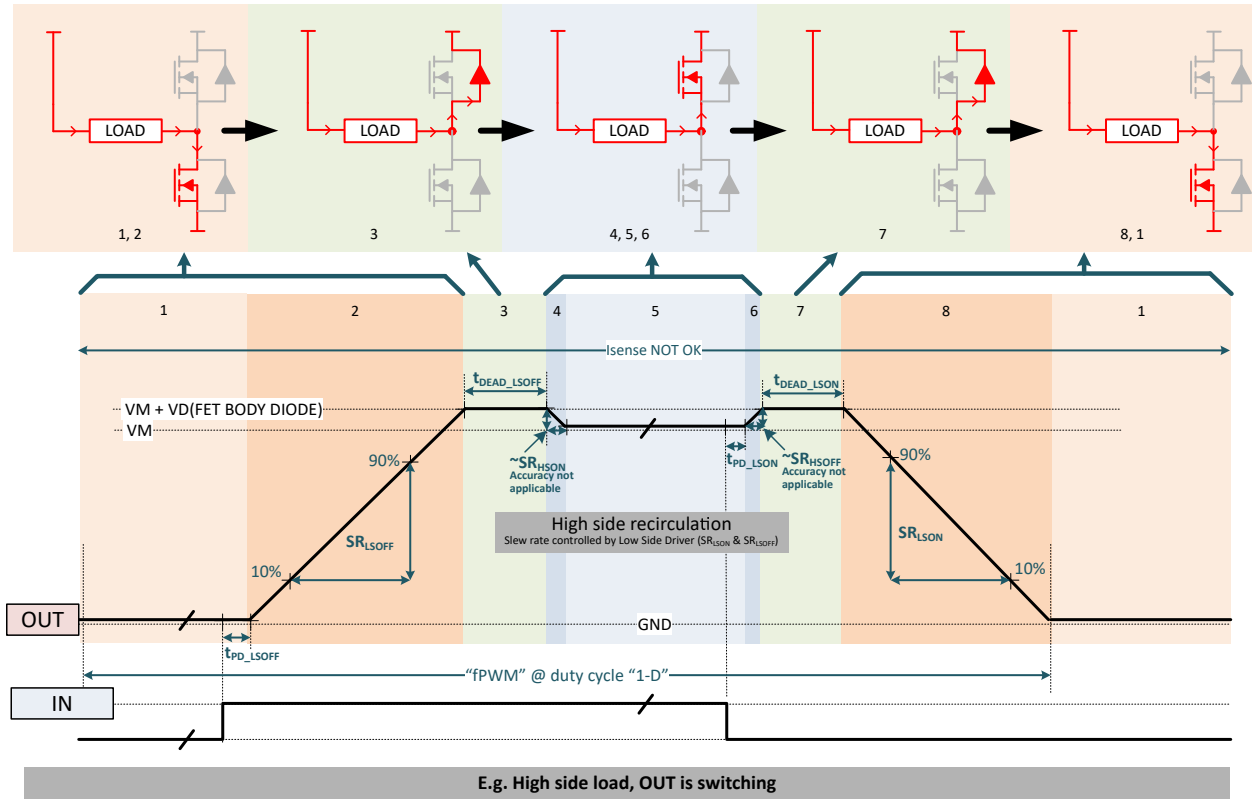

Figure 6-2. Output Switching Transients with High-Side Recirculation

6.6.1.2 Low-Side Recirculation

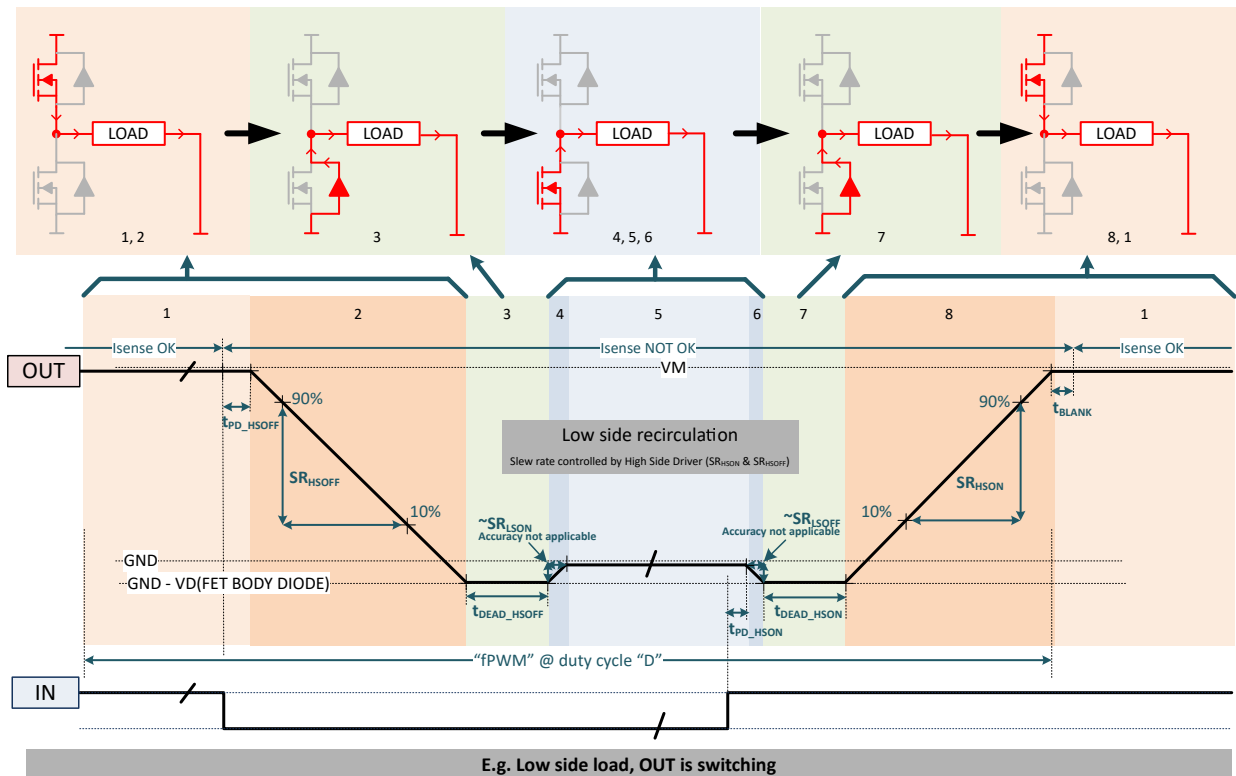

Figure 6-3. Output Switching Transients with Low-Side Recirculation

6.6.2 Wake-up Transients

6.6.2.1 HW Variant

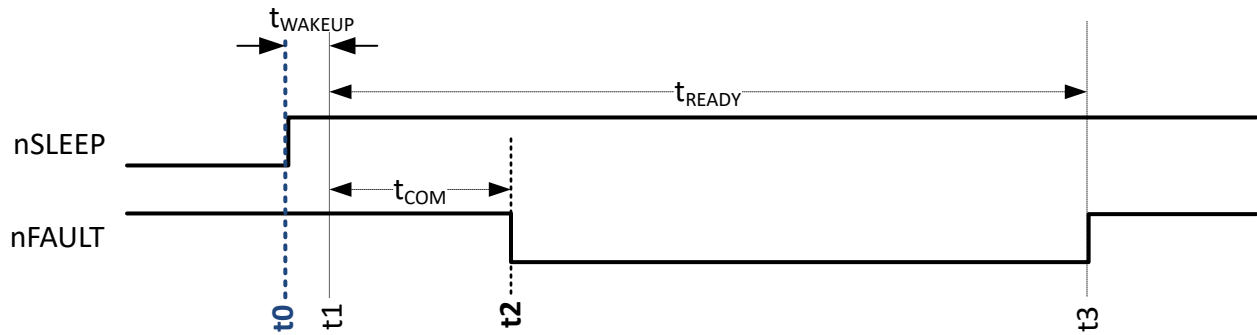

Figure 6-4. Wake-up from SLEEP State to STANDBY State

Hand shake between controller and device during wake-up as follows:

- t0: Controller - nSLEEP asserted high to initiate device wake-up
- t1: Device internal state - Wake-up command registered by device (end of Sleep state)
- t2: Device – nFAULT asserted low to acknowledge wake-up and indicate device ready for communication
- t3: Device internal state - Initialization complete. nFAULT de-asserted. Device in STANDBY state

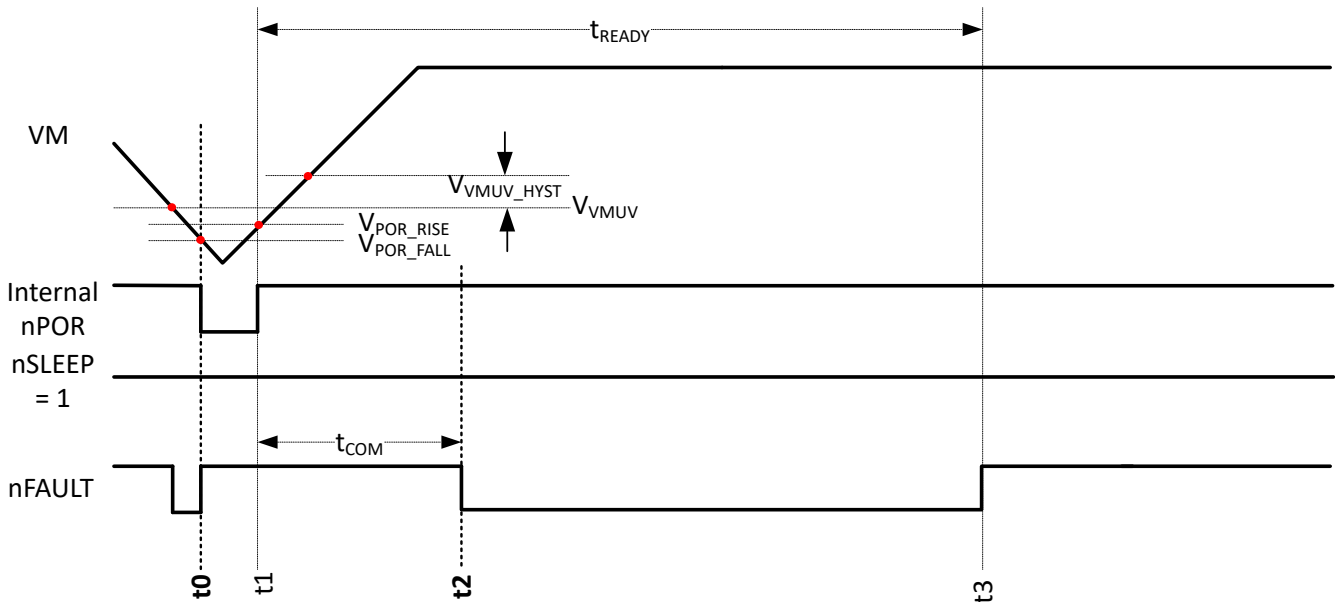

Figure 6-5. Power-up via VM to STANDBY State

Hand shake between controller and device during power-up as follows:

- t0: Device internal state - POR asserted based on under voltage of internal LDO (VM dependent)
- t1: Device internal state – POR de-asserted based on recovery of internal LDO voltage
- t2: Device – nFAULT asserted low to acknowledge wake-up and indicate device ready for communication
- t3: Device internal state - Initialization complete. nFAULT de-asserted. Device in STANDBY state

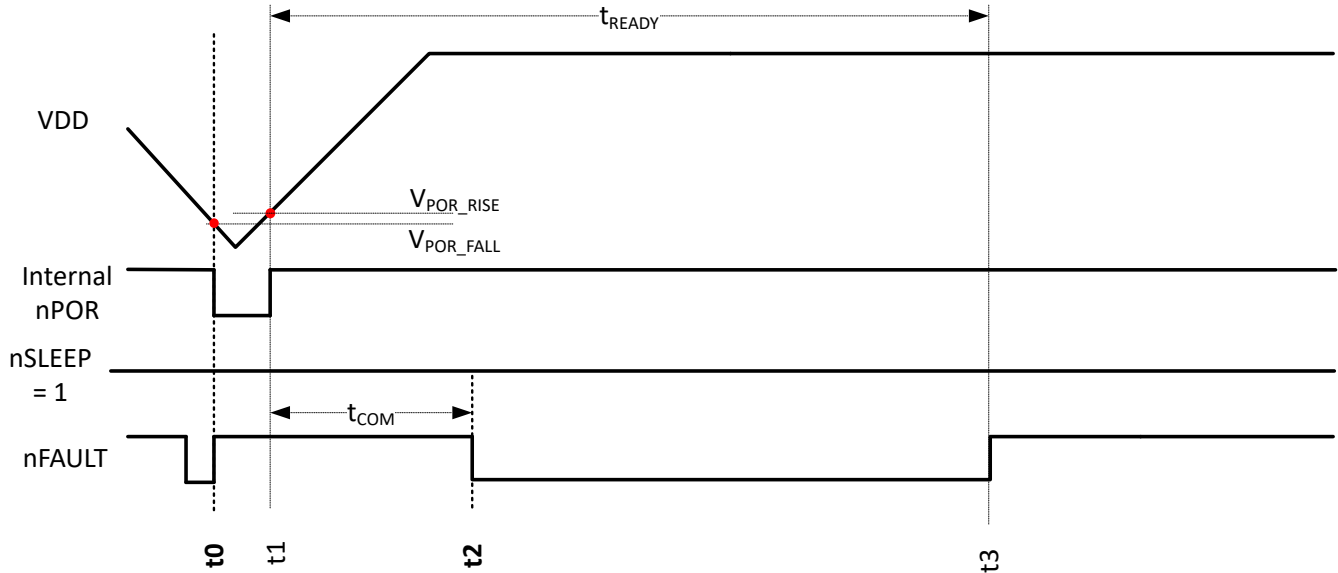

Figure 6-6. Power-up via VDD to STANDBY State

Hand shake between controller and device during power-up as follows:

- t0: Device internal state - POR asserted based on under voltage on VDD (external supply)
- t1: Device internal state – POR de-asserted based on recovery of voltage on VDD (external supply)
- t2: Device – nFAULT asserted low to acknowledge wake-up and indicate device ready for communication
- t3: Device internal state - Initialization complete. nFAULT de-asserted. Device in STANDBY state

6.6.2.2 SPI Variant

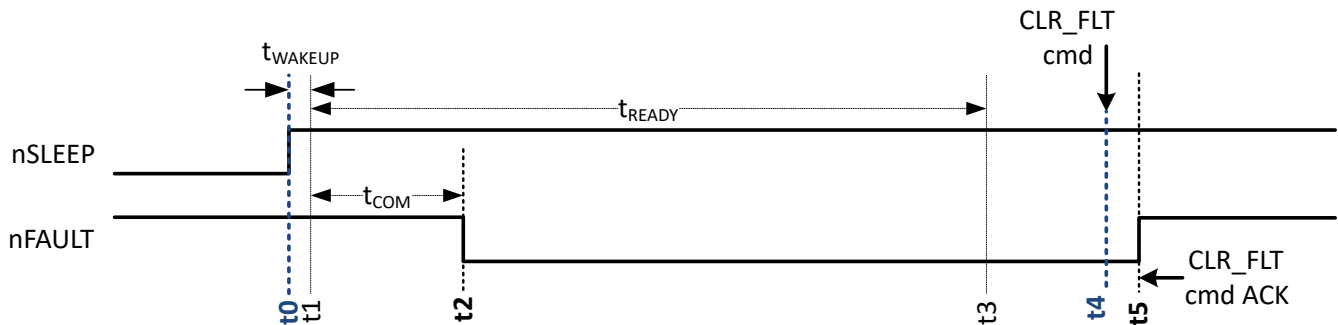

Figure 6-7. Wake-up from SLEEP State to STANDBY State

Hand shake between controller and device during a wake-up transient as follows:

- t0: Controller - nSLEEP asserted high to initiate device wake-up
- t1: Device internal state - Wake-up command registered by device (end of Sleep state)
- t2: Device – nFAULT asserted low to acknowledge wake-up and indicate device ready for communication
- t3: Device internal state - Initialization complete
- t4 (Any time after t2): **Controller – Issue CLR_FLT command** through SPI to acknowledge device wake-up
- t5: Device - nFAULT de-asserted as an acknowledgment of CLR_FLT command. Device in STANDBY state

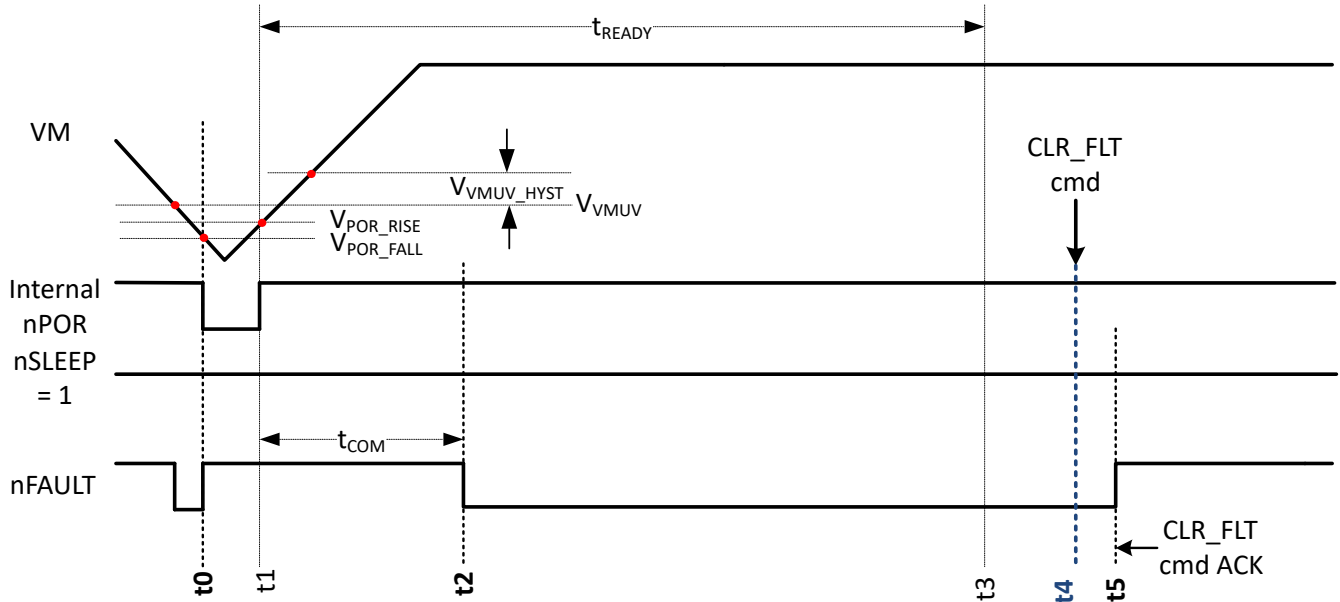

Figure 6-8. Power-up via VM to STANDBY State Transition

Hand shake between controller and device during power-up as follows:

- t0: Device internal state - POR asserted based on under voltage of internal LDO (VM dependent)
- t1: Device internal state – POR de-asserted based on recovery of internal LDO voltage
- t2: Device – nFAULT asserted low to acknowledge wake-up and indicate device ready for communication
- t3: Device internal state - Initialization complete
- t4 (Any time after t2): **Controller – Issue CLR_FLT command** through SPI to acknowledge device power-up
- t5: Device - nFAULT de-asserted as an acknowledgment of CLR_FLT command. Device in STANDBY state

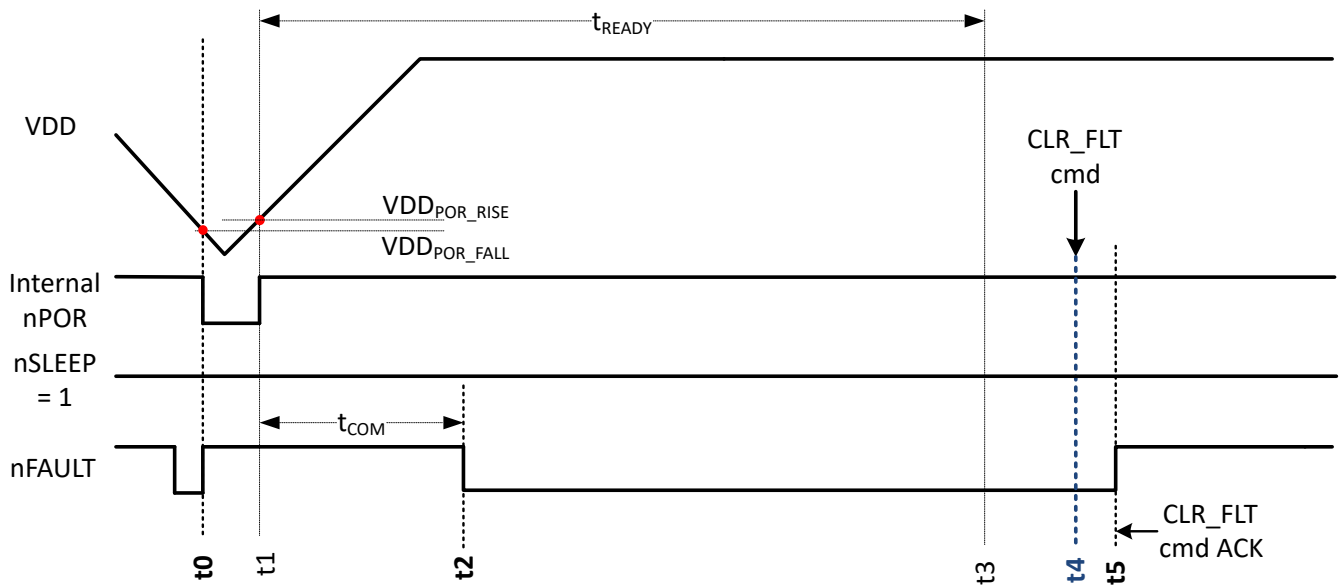

Figure 6-9. Power-up via VDD to STANDBY State Transition

Hand shake between controller and device during power-up as follows:

- t0: Device internal state - POR asserted based on under voltage on VDD (external supply)
- t1: Device internal state – POR de-asserted based on recovery of voltage on VDD (external supply)
- t2: Device – nFAULT asserted low to acknowledge wake-up and indicate device ready for communication

- t3: Device internal state - Initialization complete
- t4 (Any time after t2): **Controller – Issue CLR_FLT command** through SPI to acknowledge device power-up
- t5: Device - nFAULT de-asserted as an acknowledgment of CLR_FLT command. Device in STANDBY state

6.6.3 Fault Reaction Transients

6.6.3.1 Retry setting

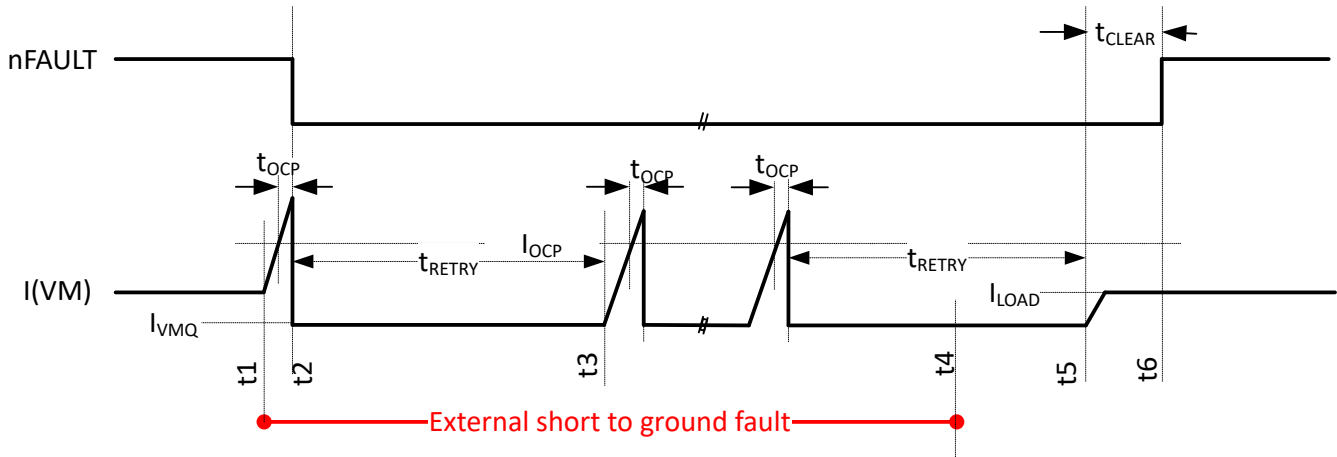

Figure 6-10. Fault reaction with RETRY setting (shown for OCP occurrence on high-side when OUT is shorted to ground)

Short occurrence and recovery scenario with RETRY setting:

- t1: An external short occurs.
- t2: OCP (Over Current Protection) fault confirmed after t_{OCP}, output disabled, nFAULT asserted low to indicate fault.
- t3: Device automatically attempts retry (auto retry) after t_{RETRY}. Each time output is briefly turned on to confirm short occurrence and then immediately disabled after t_{OCP}. nFAULT remains asserted low through out. Cycle repeats till driver is disabled by the user or external short is removed, as illustrated further. Note that, in case of a TSD (Thermal Shut Down) event, automatic retry time depends on the cool off based on thermal hysteresis.
- t4: The external short is removed.
- t5: Device attempts auto retry. But this time, no fault occurs and device continues to keep the output enabled.
- t6: After a fault free operation for a period of t_{CLEAR} is confirmed, nFAULT is de-asserted.
- SPI variant only – Fault status remains latched till a CLR_FLT command is issued.

Note that, in the event of an output short to ground causing the high-side OCP fault detection, IPROPI pin will continue to be pulled up to V_{IPROPI_LIM} voltage to indicate this type of short, while the output is disabled. This is especially useful for the HW variant to differentiate the indication of a short to ground fault from the other faults.

6.6.3.2 Latch setting

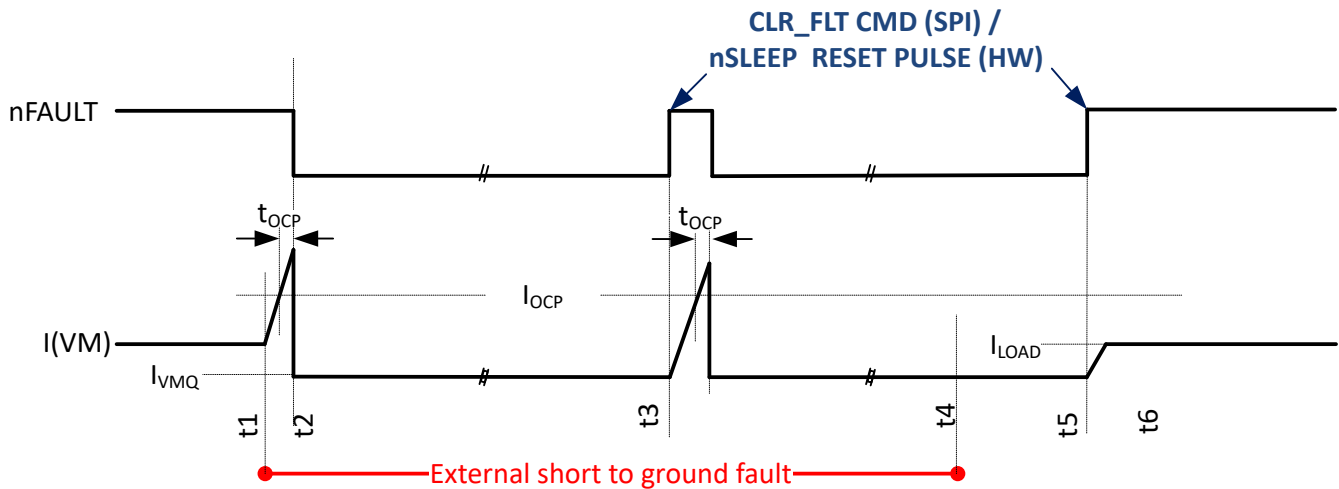

Figure 6-11. Fault reaction with Latch setting (shown for OCP occurrence on high-side when OUT is shorted to ground)

Short occurrence and recovery scenario with LATCH setting:

- t1: An external short occurs.
- t2: OCP (Over Current Protection) fault confirmed after t_{OCP} , output disabled, nFAULT asserted low to indicate fault.
- t3: A CLR_FLT command (SPI variant) or nSLEEP RESET Pulse (HW variant) issued by controller. nFAULT is de-asserted and output is enabled. OCP fault is detected again and output is disabled with nFAULT asserted low.
- t4: The external short is removed.
- t5: A CLR_FLT command (SPI variant) or nSLEEP RESET Pulse (HW variant) issued by controller. nFAULT is de-asserted and output is enabled. Normal operation resumes.
- SPI variant only – Fault status remains latched till a CLR_FLT command is issued.

Note that, in the event of an output short to ground causing the high-side OCP fault detection, IPROPI pin will continue to be pulled up to V_{IPROPI_LIM} voltage to indicate this type of short, while the output is disabled. This is especially useful for the HW variant to differentiate the indication of a short to ground fault from the other faults.

7 Detailed Description

7.1 Overview

The DRV8163-Q1 is a brushed DC motor driver that operates from 4.5 to 65V supporting a wide range of output load currents for various types of motors and loads. The device integrates a charge pump regulator to support efficient high-side N-channel MOSFETs with 100% duty cycle operation. The device operates from a single power supply input (VM) which can be directly connected to a battery or DC voltage supply. The device also provides a low-power mode to minimize current draw during system inactivity. The digital block of the device is powered by an external supply input through the VDD pin.

The device is available in two interface variants -

1. HW variant - The hardwired interface variant is available for easy device configuration. Due to the limited number of available pins in the device, this variant offers fewer configuration and fault reporting capabilities compared to the SPI variant.
2. SPI variant - A standard 4-wire serial peripheral interface (SPI) with daisy chain capability allows flexible device configuration and detailed fault reporting to an external controller. The feature differences of the SPI and HW variants can be found in the [device comparison](#) section.

The DRV8163-Q1 device provides a load current sense output using current mirrors on the high-side power MOSFETs. The IPROPI pin sources a small current that is proportional to the current in the high-side MOSFETs (current sourced out of the OUTx pin). This current can be converted to a proportional voltage using an external resistor (R_{IPROPI}). Additionally, for the SPI variant, the IPROPI pin can be programmed to output a voltage proportional to the die temperature. The device also supports a fixed off-time PWM chopping scheme for limiting current to the load. The current regulation level can be configured through the ITRIP function.

A variety of protection features and diagnostic functions are integrated into the device. These include supply voltage monitor (VMUV and VMOV), off-state (Passive) diagnostics (OLP), on-state (Active) diagnostics (OLA), overcurrent protection (OCP) for each power FET, powered-off braking (POB), over-temperature warning (OTW) and die temperature monitor, and over-temperature shutdown (TSD). Fault conditions are indicated on the nFAULT pin. The SPI variant has additional communication protection features such as frame errors and lock features for configuration register bits and driver control bits.

7.2 Functional Block Diagram

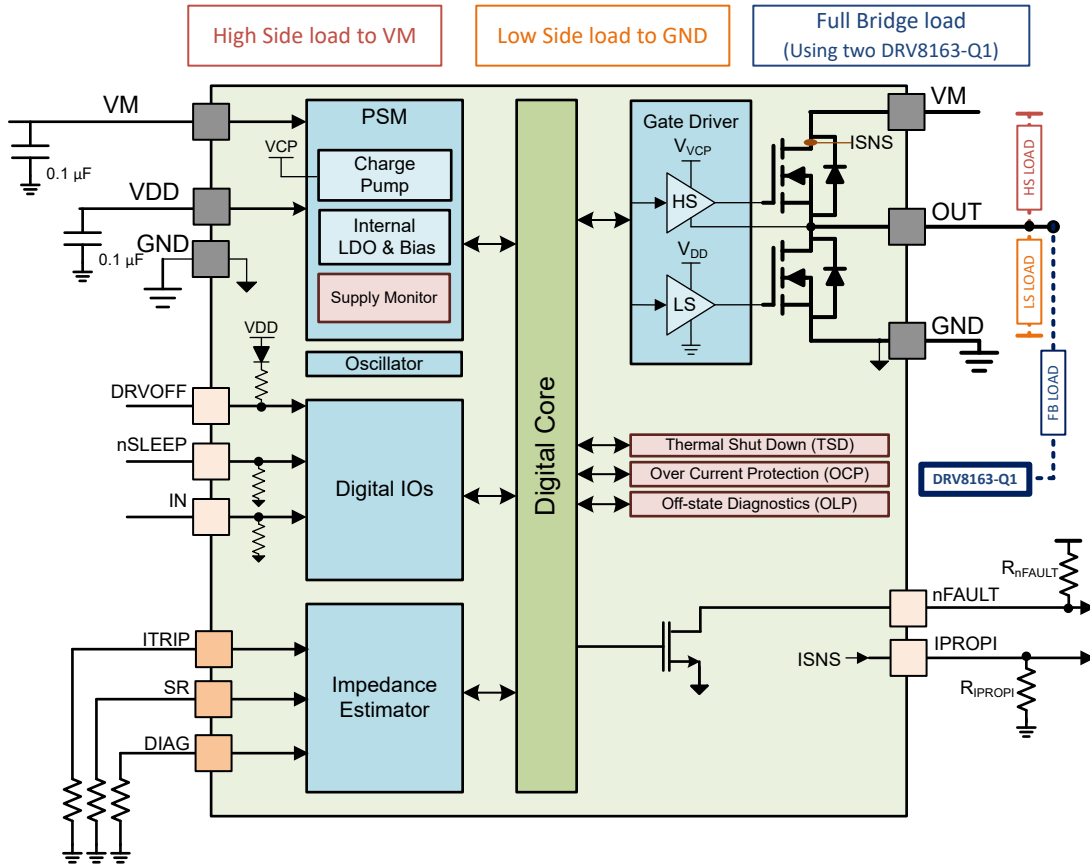

Figure 7-1. Functional Block Diagram - HW Variant

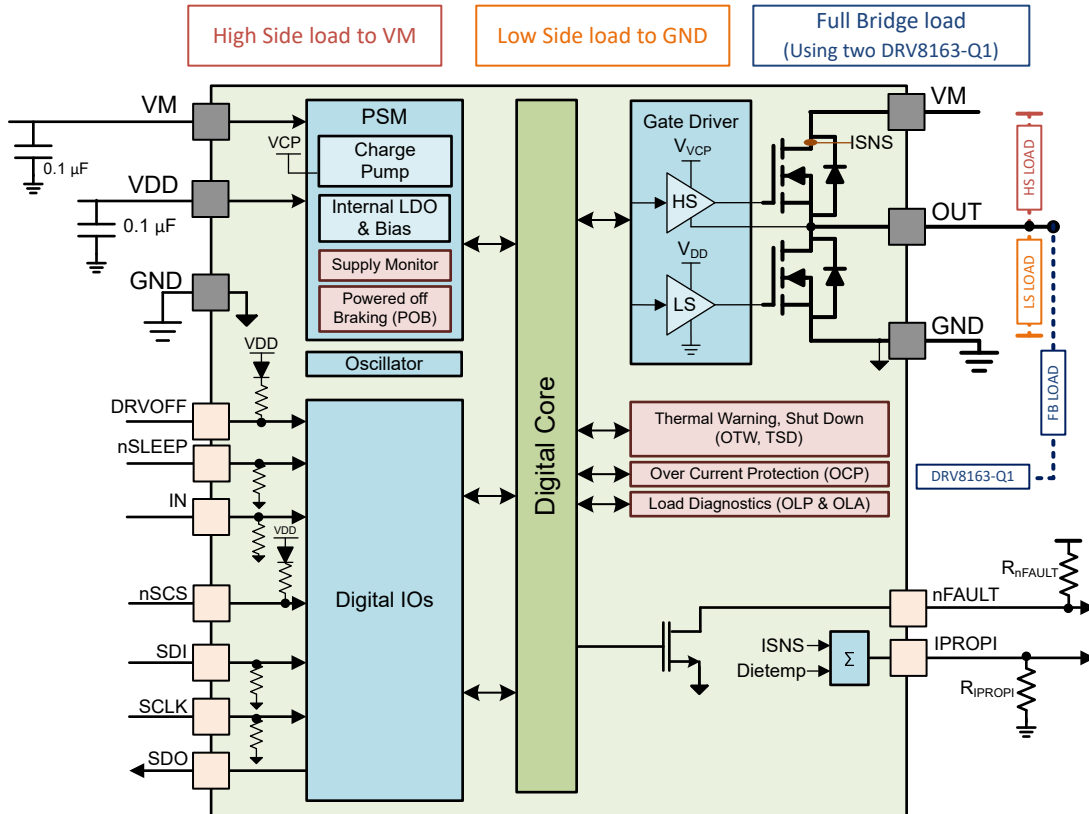

Figure 7-2. Functional Block Diagram - SPI Variant

7.3 Feature Description

7.3.1 External Components

Table 7-1 and Table 7-2 contain the recommended external components for the device.

7.3.1.1 HW Variant

Table 7-1. External Components Table for HW Variant

Component	PIN	Recommendation
C _{VM1}	VM	0.1µF, low ESR ceramic capacitor to GND rated for VM
C _{VM2}	VM	Local bulk capacitor to GND, 10µF or higher, rated for VM to handle load transients. Refer to the section on bulk capacitor sizing.
C _{VDD}	VDD	0.1µF, 6.3V, low ESR ceramic capacitor to GND.
R _{IPROPI}	IPROPI	Typically 500 - 5000Ω 0.063 W resistor to GND, depending on the controller ADC dynamic range. The pin can be shorted to GND if ITRIP and IPROPI function is not needed.
C _{IPROPI}	IPROPI	Optional 10 - 100nF, 6.3V capacitor to GND to slow down the ITRIP regulation loop. Refer Over Current Protection (OCP) section .
R _{nFAULT}	nFAULT	Typically 1KΩ - 10KΩ, 0.063W pull-up resistor to controller supply.
R _{SR}	SR	Open or short to GND or 0.063W 10% resistor to GND depending on the setting. Refer SR section .
R _{ITRIP}	ITRIP	Open or short to GND or 0.063W 10% resistor to GND depending on the setting. Refer ITRIP table .
R _{DIAG}	DIAG	Open or short to GND or 0.063W 10% resistor to GND depending on the setting. Refer DIAG section .

7.3.1.2 SPI Variant

Table 7-2. External Components Table for SPI Variant

Component	PIN	Recommendation
C _{VM1}	VM	0.1µF, low ESR ceramic capacitor to GND rated for VM
C _{VM2}	VM	Local bulk capacitor to GND, 10µF or higher, rated for VM to handle load transients. Refer to the section on bulk capacitor sizing.
C _{VDD}	VDD	0.1µF, 6.3V, low ESR ceramic capacitor to GND.
R _{I_{PROPI}}	I _{PROPI}	Typically 500 - 5000 Ω 0.063W resistor to GND, depending on the controller ADC dynamic range. The pin can be shorted to GND if ITRIP and I _{PROPI} function is not needed.
C _{I_{PROPI}}	I _{PROPI}	Optional 10 - 100nF, 6.3V capacitor to GND to slow down the ITRIP regulation loop. Refer Over Current Protection (OCP) section .
R _{n_{FAULT}}	n _{FAULT}	Typically 1KΩ - 10KΩ, 0.063W pull-up resistor to controller supply. If n _{FAULT} signaling is not used, this pin can be short to GND or left open.

7.3.2 Bridge Control

The DRV8163-Q1 provides a simple two pin control of the output through the pins, DRVOFF and IN.

The inputs can accept static or pulse-width modulated (PWM) voltage signals for either 100% or PWM drive modes. The device input pins can be powered before VM is applied. By default, the nSLEEP and DRVOFF pins have an internal pull-down and pull-up resistor respectively, to maintain the outputs are Hi-Z if no inputs are present. The IN pin also has an internal pull down resistor.

The device automatically generates the desired dead-time needed during transitioning between the high-side and low-side FET on the switching half-bridge. This timing is based on internal FET gate-source voltage feedback. No external timing is required. This scheme provides for minimum dead time, while guaranteeing no shoot-through current.

Note

1. The SPI variant also provides additional control through the SPI_IN register bits. Refer to - [Register - Pin control](#).

The table below shows the logic table for bridge control. For load illustration, refer the [Section 9.1.1](#).

Table 7-3. Control table

nSLEEP	DRVOFF	IN	OUT	Device State
0	X	X	Hi-Z	SLEEP
1	1	0	Hi-Z	STANDBY
1	1	1	Refer table	STANDBY
1	0	0	L	ACTIVE
1	0	1	H ⁽¹⁾	ACTIVE

(1) If internal ITRIP regulation is enabled and ITRIP level is reached, then OUTx is forced "L" for a fixed time

7.3.2.1 Register - Pin Control - SPI Variant Only

The SPI variant allows control of the bridge through the specific register bits, S_DRVOFF, S_IN in the [SPI_IN](#) register, provided the **SPI_IN register has been unlocked**. The user can unlock this register by writing the right combination to the SPI_IN_LOCK bits in the [COMMAND](#) register.

Additionally, the user can configure between an AND / OR logic combination of each of external input pin with their equivalent register bit in the SPI_IN register. This logical configuration is done through the equivalent selects bits in the [CONFIG4](#) register:

- DRV_SEL and IN_SEL

The control of the output is similar to the truth tables described in the section before, but with these logically combined inputs. These combined inputs are listed as follows:

- Combined input = Pin input **OR** equivalent SPI_IN register bit, if equivalent CONFIG4 select bit = 0b
- Combined input = Pin input **AND** equivalent SPI_IN register bit, if equivalent CONFIG4 select bit = 1b

Note that external nSLEEP pin is still needed for sleep function.

This logical combination offers more configurability to the user as shown in the table below.

Table 7-4. Register - Pin Control Examples

Example	CONFIG4: xxx_SEL Bit	PIN status	SPI_IN Bit Status	Comment
DRVOFF as redundant shutoff	DRV_SEL = 0b	DRVOFF active	S_DRVOFF active	Either DRVOFF pin = 1 or S_DRVOFF bit = 1 will shutoff the output
Pin only control	DRV_SEL = 1b	DRVOFF active	S_DRVOFF = 1b	Only DRVOFF pin function is available
Register only control	IN_SEL = 0b	IN - short to GND or float	S_IN active	IN function will be controlled by the register bit alone

7.3.3 Device Configuration

This section describes the various device configurations to enable the user to configure the device to suit their use case.

7.3.3.1 Slew Rate (SR)

The SR pin (HW variant) or SR bit in the [CONFIG3](#) register (SPI variant) determines the voltage slew rate of the driver output. This enables the user to optimize the PWM switching losses while meeting the EM conformance requirements. The device supports four slew rate settings. Depending on the use case, refer to the switching parameters table for either high-side recirculation or low-side recirculation in the [Electrical Characteristics](#) section for the slew rate range and values.

Note

The SPI variant also offers an **optional** spread spectrum clocking (SSC) feature that spreads the internal oscillator frequency +/- 12% around its mean with a period triangular function of ~1.3MHz to reduce emissions at higher frequencies. There is **no** spread spectrum clocking (SSC) feature in the HW variant.

In the HW variant, the SR pin is **latched** during device initialization following power-up or wake-up from sleep. Update during operation is blocked.

In the SPI variant, the slew rate setting can be changed at any time when SPI communication is available by writing to the SR bit. This change is immediately reflected.

7.3.3.2 IPROPI

The device features an output (IPROPI pin) for current sensing and die temperature measurement. This information can be used for status or regulation of loads (on OUTx), or to check die temperature. These integrated features eliminate the need for multiple external sense resistors or sense circuitry, reducing system size, cost and complexity.

The device senses the load current by using a shunt-less high-side current mirror topology. This way the device can only sense an uni-directional high-side current from VM → OUT → Load through the high-side FET when it is fully turned ON (linear mode).

The IPROPI pin must be connected to an external resistor (R_{IPROPI}) to ground in order to generate a proportional voltage V_{IPROPI} . This allows for the load current to be measured as a voltage-drop across the R_{IPROPI} resistor with an analog to digital converter (ADC). The R_{IPROPI} resistor can be sized based on the expected load current in the application so that the full range of the controller ADC is utilized.

Depending on the ISEL bits setting, the IPROPI output can also provide analog voltage representation of the die temperature. This is intended for use in testing and evaluation, but not during device run-time.

Table 7-5. ISEL settings for DRV8163-Q1

ISEL	IPROPI
11b	$I_{HS} \times A_{IPROPI}$
00b	Die Temperature Readout

Note

ISEL = 01b or 10b are not recommended

When the IPROPI output is configured for die temperature readout, the device outputs a current as per the following formula -

$$\text{Current } (\mu\text{A}) = 3.0054 * (\text{Temperature in } ^\circ\text{C}) + 779$$

This equation is valid for temperatures between -40 °C and 185 °C. For example, when the die temperature is 85° C and ISEL is selected for the die temperature readout, current out of the IPROPI pin will be 1.035mA.

7.3.3.3 ITRIP Regulation

The device offers an optional internal load current regulation feature using fixed TOFF time method. This is done by comparing the voltage on the IPROPI pin against a reference voltage determined by ITRIP setting. TOFF time is fixed at 30µsec for HW variant, while it is configurable between or 20 to 50µsec for the SPI variant using TOFF bits in the [CONFIG3](#) register.

The ITRIP regulation, when enabled, comes into action only when the HS FET is enabled and current sensing is possible. In this scenario, when the voltage on the IPROPI pin exceeds the reference voltage set by the ITRIP setting, the internal current regulation loop forces the following action:

- OUT = L for a fixed TOFF time

Note

The user inputs always takes **precedence** over the internal control. That means that if the inputs change during the TOFF time, the remainder of the TOFF time is ignored and the outputs will follow the inputs as commanded.

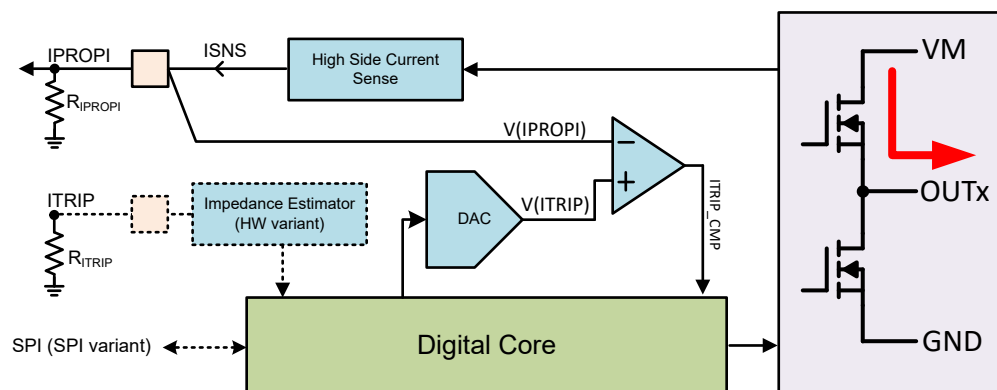

Figure 7-3. ITRIP Implementation

The current limit is set by the following equation:

$$\text{ITRIP regulation level} = V_{ITRIP} / (R_{IPROPI} \times A_{IPROPI}) \tag{2}$$

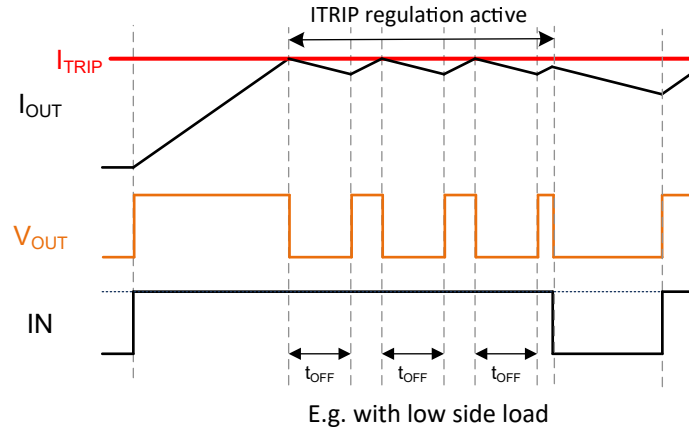

Figure 7-4. Fixed TOFF ITRIP Current Regulation

The ITRIP comparator output (ITRIP_CMP) is ignored during output slewing to avoid false triggering of the comparator output due to current spikes from the load capacitance. Additionally, in the event of transition from low-side recirculation, an additional blanking time t_{BLANK} is needed for the sense loop to stabilize before the ITRIP comparator output is valid.

ITRIP is a 6-level setting for the HW variant. The SPI variant offers two more settings. This is summarized in the table below:

Table 7-6. ITRIP Table

ITRIP Pin	S_ITRIP Register Bits	V_{ITRIP} [V]
R_LVL1	000b	Regulation Disabled
R_LVL2	001b	1.18
Not available	010b	1.41
Not available	011b	1.65
R_LVL3	100b	1.98
R_LVL4	101b	2.31
R_LVL5	110b	2.64
R_LVL6	111b	2.97

In the HW variant of the device, the ITRIP pin changes are **transparent** and changes are reflected immediately.

In the SPI variant of the device, the ITRIP setting can be changed at any time when SPI communication is available by writing to the S_ITRIP bits. This change is immediately reflected in the device behavior.

SPI variant only - If the ITRIP regulation levels are reached, the ITRIP_CMP bit in the [STATUS1](#) register is set. There is no nFAULT pin indication. This bit can be cleared with a CLR_FLT command.

Note

If the application requires a linear ITRIP control with multiple steps beyond the choices provided by the device, an external DAC can be used to force the voltage on the bottom side of the IPROPI resistor, instead of terminating it to GND. With this modification, the ITRIP current can be controlled by the external DAC setting as follows:

$$\text{ITRIP regulation level} = (V_{ITRIP} - V_{DAC}) / (R_{IPROPI} \times A_{IPROPI}) \quad (3)$$

7.3.3.4 DIAG

The DIAG is a pin (HW variant) or register (SPI variant) setting that is used in both ACTIVE and STANDBY operation of the device, as follows:

- STANDBY state
 - Enable or disable [Off-state diagnostics \(OLP\)](#), as well as select the OLP combinations when enabled. Refer to the tables in the [Off-state diagnostics \(OLP\)](#) section for details on this.
- ACTIVE state
 - Mask ITRIP regulation function if the load type is indicated as high-side load.
 - SPI variant only - Mask active open load detection (OLA) if the load type is indicated as low-side load.
 - HW variant only - configure device wake-up and fault reaction between retry and latch settings

7.3.3.4.1 HW variant

For the HW variant, the DIAG pin is a 6-level setting. Depending on the mode, the configurations are summarized in the table below.

Table 7-7. DIAG table for HW variant

DIAG pin	STANDBY state	ACTIVE state		
	Off-state diagnostics	Fault reaction	IPROPI / ITRIP	Comment
R _{LVL1}	Disabled	Retry	Available	Use for low-side load
R _{LVL2}	Enabled ⁽¹⁾	Latch	Available	
R _{LVL3}	Enabled ⁽¹⁾	Latch	Disabled	Use for high-side load
R _{LVL4}	Enabled ⁽¹⁾	Retry	Disabled	
R _{LVL5}	Disabled	Latch	Available	Use for low-side load
R _{LVL6}	Enabled ⁽¹⁾	Retry	Available	

(1) Refer to the tables in the [Off-state diagnostics \(OLP\)](#) section for combination details

Note

HW variant only - Option to disable off-state diagnostics for a high-side load use case is not supported. In this case, setting DRVOFF pin high and IN pin low is only way to disable off-state diagnostics.

In the HW variant, the DIAG pin is **latched** during device initialization following power-up or wake-up from sleep. Update during operation is blocked.

7.3.3.4.2 SPI variant

For the SPI variant, S_DIAG is a 2-bit setting in the [CONFIG2](#) register. Depending on the mode, its configurations are summarized in the table below.

Table 7-8. DIAG table for the SPI variant

S_DIAG bits	STANDBY state	ACTIVE state		
	Off-state diagnostics	On-state diagnostics	IPROPI / ITRIP	Comment
00b	Disabled	Disabled	Available	Use for low-side load
01b	Enabled ⁽¹⁾	Disabled	Available	
10b	Disabled	Available	Disabled	Use for high-side load
11b	Enabled ⁽¹⁾	Available	Disabled	

(1) Refer to the tables in the [Off-state diagnostics \(OLP\)](#) section for combination details

In the SPI variant of the device, the settings can be changed anytime when SPI communication is available by writing to the S_DIAG bits. This change is immediately reflected.

7.3.4 Protection and Diagnostics

The driver is protected against over-current and over-temperature events to ensure device robustness. Additionally, the device also offers load monitoring (on-state and off-state) and over / under voltage monitoring on VM pin to signal any unexpected conditions. Fault signaling is done through a low-side open drain nFAULT

pin which gets pulled to GND on detection of a fault condition. Transition to SLEEP state automatically de-asserts nFAULT.

Note

In the SPI variant, nFAULT pin logic level is the inverted copy of the FAULT bit in the FAULT register. Only exception is when off-state diagnostics are enabled and SPI_IN register is locked (Refer [OLP section](#)).

For the SPI variant, whenever nFAULT is asserted low, the device logs the fault into the FAULT and STATUS registers. These registers can be cleared only by CLR_FLT command.

It is possible to get all the useful diagnostic information for periodic software monitoring in a single 16 bit SPI frame by:

- Reading the STATUS1 register during ACTIVE state
- Reading the STATUS2 register during STANDBY state

All the diagnosable fault events can be uniquely identified by reading the STATUS registers.

7.3.4.1 Over Current Protection (OCP)

- Device state: ACTIVE
- Mechanism & thresholds: An analog current limit circuit on each MOSFET limits the peak current out of the device even in hard short circuit events. If the output current exceeds the overcurrent threshold, I_{OCP} , for longer than t_{OCP} , then an over current fault is detected.
- Action:
 - nFAULT pin is asserted low
 - OUT is Hi-Z
 - For a short to GND fault (over current detected on the high-side FET), the IPROPI pin continues to be pulled up to V_{IPROPI_LIM} even if the FET has been disabled. For the HW variant, this helps differentiate a short to GND fault during ACTIVE state from other fault types, as the IPROPI pin is pulled high while the nFAULT pin is asserted low.
- Reaction configurable between latch setting and retry setting based on t_{RETRY} and t_{CLEAR}
- User can add a capacitor in the range of 10nF to 100nF on the IPROPI pin to ensure OCP detection in case of a load short condition when internal ITRIP regulation is enabled. This is especially true where there is enough inductance in the short that causes ITRIP regulation to trigger ahead of the OCP detection, resulting in the device missing the short detection. To ensure that OCP detection wins this race condition, a small capacitance added on the IPROPI pin slows down the ITRIP regulation loop enough to allow the OCP detection circuit to work as intended.

The SPI variant offers configurable I_{OCP} levels and t_{OCP} filter times. Refer [CONFIG4](#) register for these settings.

7.3.4.2 Over Temperature Warning (OTW) - SPI Variant Only

- Device state: STANDBY, ACTIVE
- Mechanism & thresholds: if the die temperature exceeds T_{OTW} for a time greater than t_{OTW} , then an over temperature warning is detected.
- The OTW_SEL bit programs the T_{OTW} levels. Refer [CONFIG1](#) register for these settings.
- Action:
 - OTW bit is made 1b
 - The device performs no additional action and continues to function
 - If OTW_REP bit is 1b -
 - nFAULT output is pulled low
 - FAULT bit is made 1b
- When the die temperature falls below the hysteresis point (T_{HYS_OTW}) of the overtemperature warning, the OTW bit clears automatically.

7.3.4.3 Over Temperature Protection (TSD)

- Device state: STANDBY, ACTIVE
- Mechanism & thresholds: If the device detects an over temperature event, set by T_{TSD} for a time greater than t_{TSD} , then an over temperature fault is detected.
- Action:
 - nFAULT pin is asserted low
 - OUT is Hi-Z
 - IPROPI pin is Hi-Z
- Reaction configurable between latch setting and retry setting based on T_{HYS} and t_{CLEAR_TSD}

7.3.4.4 Off-State Diagnostics (OLP)

The user can determine the impedance on the OUT node using off-state diagnostics in the STANDBY state when the power FETs are off. With this diagnostics, it is possible to detect the following fault conditions passively in the STANDBY state:

- Output short to VM or GND < 100Ω
- Open load > 1KΩ for low-side load
- Open load > 10KΩ for high-side load, VM = 48V

Note

It is NOT possible to detect a **load short** with this diagnostic. However, the user can deduce this logically if an over-current fault (OCP) occurs during ACTIVE operation, but OLP diagnostics do not report any fault in the STANDBY state. The occurrence of both OCP in the ACTIVE state and OLP in the STANDBY state would imply a terminal short (short on OUT node).

- The user can configure the following combinations
 - Internal pull up resistor (R_{OLP_PU}) on OUT
 - Internal pull down resistor (R_{OLP_PD}) on OUT
 - Comparator reference level
- This combination is determined by the controller inputs (pins only for the HW variant) or equivalent bits in the [SPI_IN](#) register for the SPI variant if the SPI_IN register has been unlocked.
- HW variant - When off-state diagnostics are enabled, comparator output (OLP_CMP) is available on nFAULT pin.
- SPI variant - The off-state diagnostics comparator output (OLP_CMP) is available on OLP_CMP bit in [STATUS2](#) register. Additionally, if the SPI_IN register has been locked, this comparator output is also available on the nFAULT pin when off-state diagnostics are enabled.
- The user is expected to toggle through all the combinations and record the comparator output after its output is settled.
- Based on the input combinations and comparator output, the user can determine if there is a fault on the output.

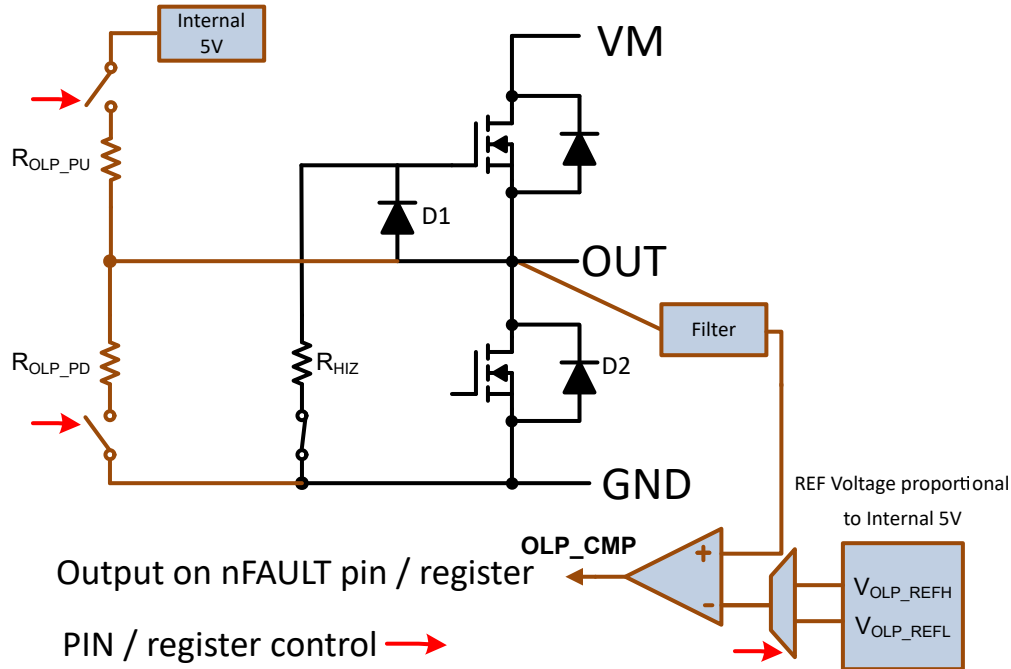

Figure 7-5. Off-State (Passive) Diagnostics

The OLP combinations and truth table for a no fault scenario vs. fault scenario for a low-side load is shown in Table 7-9.

Table 7-9. Off-State Diagnostics Table for a Low-Side Load

User Inputs					OLP Set-Up		OLP_CMP Output		
DIAG Pin	S_DIAG Bits	nSLEEP	DRVOFF	IN	OUT	CMP REF	Normal	Open	Short
LVL2, LVL6	01b	1	1	1	R _{OLP_PU}	V _{OLP_REFH}	L	H	H
LVL3, LVL4	11b	1	1	1	R _{OLP_PD}	V _{OLP_REFL}	L	L	H

The OLP combinations and truth table for a no fault scenario vs. fault scenario for a high-side load is shown in Table 7-10.

Table 7-10. Off-State Diagnostics Table for a High-Side Load

User Inputs					OLP Set-Up		OLP_CMP Output		
DIAG Pin	S_DIAG Bits	nSLEEP	DRVOFF	IN	OUT	CMP REF	Normal	Open	Short
LVL2, LVL6	01b	1	1	1	R _{OLP_PU}	V _{OLP_REFH}	H	H	L
LVL3, LVL4	11b	1	1	1	R _{OLP_PD}	V _{OLP_REFL}	H	L	L

7.3.4.5 On-State Diagnostics (OLA) - SPI Variant Only

- Device state: ACTIVE - high-side recirculation
- Mechanism and threshold: On-state diagnostics (OLA) can detect an open load detection in the ACTIVE state during high-side recirculation. This includes high-side load connected directly to VM or through a high-side FET on the other half-bridge. During a PWM switching transition, the inductive load current re-circulates into VM through the HS body diode when the LS FET is turned OFF. The device looks for a voltage spike on OUTx above VM during the brief dead time, before the HS FET is turned ON. To observe the voltage spike, this load current needs to be higher than the pull down current (I_{PD_OLA}) on the output asserted by the FET driver. Device has configurable bit OLA_FLTR (CONFIG4) for either "16" or "1024" consecutive re-circulation

switching cycles with absence of this voltage spike to indicate a loss of load inductance or increase in load resistance and is detected as an OLA fault.

- Action:
 - nFAULT pin is asserted low
 - Output - normal function maintained
 - IPROPI pin - normal function maintained
- Reaction configurable between latch setting and retry setting. In retry setting, OLA fault is automatically cleared with the detection of either "16" or "1024" consecutive voltage spikes during re-circulation switching cycles.
- OLA Fault Behavior during direction change:
 - Retry mode - If an open load condition is detected on OUTx, OLAx bit is set if condition persists for longer than the filter time. OLAx filter is cleared on direction change.
 - Latch mode - If an open load condition is detected on OUTx, OLAx is set if condition persists for longer than the filter time. OLAx remains latched until a CLR_FLT command is issued. OLAx filter is cleared on direction change.
- OLA Fault Behavior during CLR_FLT command:
 - Retry mode - CLR_FLT command is not used.
 - Latch mode - If an open load condition is detected on OUT1, OLA1 is set if condition persists for longer than the filter time. OLAx remains latched until a CLR_FLT command is issued, which is cleared regardless of open load condition. If the condition does exist, OLA fault will be reported again after the filter time.

This monitoring is optional and can be disabled.

Note

OLA is not supported for low-side loads (low-side recirculation).

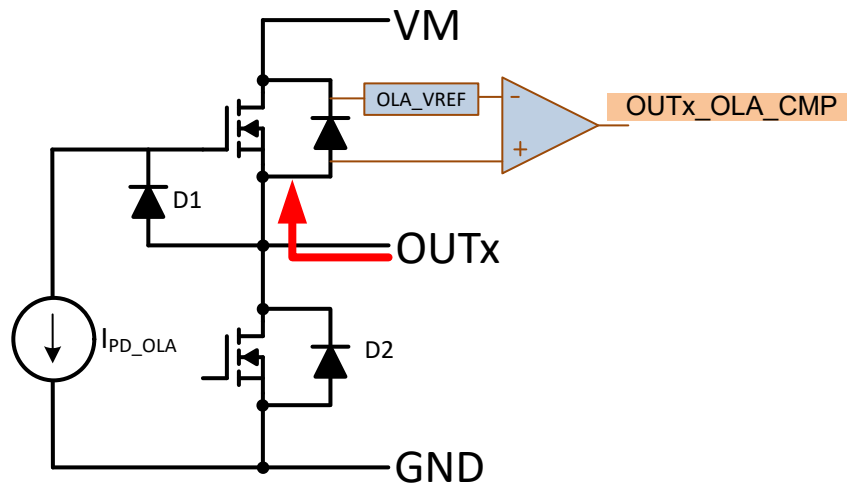

Figure 7-6. On-State Diagnostics

7.3.4.6 VM Over Voltage Monitor - SPI Variant Only

- Device state: STANDBY, ACTIVE
- Mechanism & thresholds: If the supply voltage on the VM pin exceeds the threshold, set by V_{VMOV} for a time greater than t_{VMOV} , then an VM over voltage fault is detected.
- Action:
 - nFAULT pin is asserted low
 - Output - normal function maintained
 - IPROPI pin - normal function maintained

- Reaction configurable between retry and latch setting

This monitoring is optional and can be disabled by making the OVSEL bit 1b.

7.3.4.7 VM Under Voltage Monitor

- Device state: STANDBY, ACTIVE
- Mechanism & thresholds: If the supply voltage on the VM pin drops below the threshold, set by V_{VMUV} for a time greater than t_{VMUV} , then an VM under voltage fault is detected.
- Action:
 - nFAULT pin is asserted low
 - OUT is Hi-Z
 - IPROPI pin is Hi-Z
- HW variant: Reaction configurable between retry and latch as per DIAG setting
- SPI variant: Reaction configurable between retry and latch setting
- Note that retry time is only dependent on recovery of VM under voltage condition and is independent of t_{RETRY} / t_{CLEAR} times

7.3.4.8 Power On Reset (POR)

- Device state: ALL
- Mechanism & thresholds: If VDD drops below V_{POR_FALL} for a time greater than t_{POR} , then a power on reset will occur that will hard reset the device.
- Action:
 - nFAULT pin is de-asserted
 - OUT is Hi-Z
 - IPROPI pin is Hi-Z.
 - When VDD recovers above the V_{POR_RISE} level, the device will go through a wake-up initialization and nFAULT pin will be asserted low to notify the user on this reset (Refer [Wake-up transients](#)).
- Fault reaction: Always retry, retry time depends on the external supply condition to initiate a device wake-up

7.3.4.9 Powered off Braking (POB)

When the motor is driven by external force, it acts as a generator and pumps back current to the supply voltage rail. This can potentially damage other circuits connected to the supply rail. The powered off braking (POB) feature is implemented to prevent the increase in the supply voltage.

In low-power sleep mode or when the bridge is disabled (Hi-Z), if the supply voltage is more than V_{VMOV_POB} and if the voltage of the output nodes rise above the supply voltage by more than V_{POB_TH} , the device turns on the low-side MOSFET. This allows the device to actively brake a motor connected to the outputs by shorting the back emf across the motor terminals.

The powered off braking (POB) function is disabled by default. After power-up, the EN_POB bit in [CONFIG3](#) register can be made 1b to enable this feature. The EN_POB logic state is latched, so that in sleep mode the device behaves as per the EN_POB bit setting, even though the internal digital logic is reset. The VDD supply must be present to latch the EN_POB logic state.

In sleep mode, in case of a short circuit to power supply fault present on the power stage, a simple overcurrent detector circuit with analog RC deglitch filter is provided to disable the low-side MOSFET if a high current event is detected while braking. This is needed since the normal overcurrent protection circuits are disabled during the device low-power sleep mode. The overcurrent comparator and RC deglitch filter values are fixed and cannot be adjusted.

7.3.4.10 Event Priority

In the ACTIVE state, in a scenario where two or more events occur simultaneously, the device assigns control of the driver based on the following priority table.

Table 7-11. Event Priority Table

Event	Priority
User SLEEP command	1

Table 7-11. Event Priority Table (continued)

Event	Priority
User input: DRVOFF	2
Over temperature detection (TSD)	3
Over current detection (OCP) ⁽¹⁾	4
VM under voltage detection (VMUV)	5
Under input: IN	6
Internal PWM control from ITRIP regulation	7
VM over voltage detection (VMOV)	8

(1) If the device is waiting for an OCP event to be confirmed (waiting for t_{OCP}) when any of events with lower priority than OCP occur, then the device may delay servicing the other events up to a maximum time of t_{OCP} to enable detection of the OCP event.

7.3.5 Device Functional Modes

The device has three functional states:

- SLEEP
- STANDBY
- ACTIVE

These states are described in the following section.

7.3.5.1 SLEEP State

This state occurs when nSLEEP pin is asserted low for a time $> t_{SLEEP}$ or voltage on the VDD pin is $< VDD_{POR_FALL}$.

This is the deep sleep low power (I_{SLEEP}) state of the device where all functions except a wake-up command are not serviced. The drivers are in Hi-Z. The internal power supply rails (5 V and others) are powered off. nFAULT pin is de-asserted in this state. The device can enter this state from either the STANDBY or the ACTIVE state.

7.3.5.2 STANDBY State

The device is in this state when nSLEEP pin is asserted high, the voltage on the VDD pin is $> VDD_{POR_RISE}$ and DRVOFF = logic-high. In this state, the device is powered up ($I_{STANDBY}$), with the driver Hi-Z and nFAULT de-asserted. The device is ready to transition to ACTIVE state or SLEEP state when commanded so. Off-state diagnostics (OLP), if enabled, are done in this state.

7.3.5.3 Wake-up to STANDBY State

The device starts transition from SLEEP state to STANDBY state

- if the nSLEEP pin goes high for a duration longer than t_{WAKE} , or
- if VM supply $> VM_{POR_RISE}$ or VDD supply $> VDD_{POR_RISE}$ such that internal POR is released to indicate a power-up.

The device goes through an initialization sequence to load its internal registers and wake-up all the blocks in the following sequence:

- At a certain time, t_{COM} from wake-up, the device is capable of communication. This is indicated by asserting the nFAULT pin low.
- This is followed by the time t_{READY} , when the device wake-up is complete.
- At this point, the HW variant device will enter STANDBY mode. For SPI variant, once the device receives a **CLR FAULT** command through SPI as an acknowledgment of the wake-up from the controller, the device enters the STANDBY state. This is indicated by the de-assertion of the nFAULT pin. The driver is held in Hi-Z till this point.
- From here on, the device is ready to drive the bridge based on the truth tables.

Refer to the [wake-up transients waveforms](#) for the illustration.

7.3.5.4 ACTIVE State

The device is fully functional in this state with the drivers controlled by other inputs as described in prior sections. All protection features are fully functional with fault signaling on nFAULT pin. SPI communication is available. The device can transition into this state only from the STANDBY state.

7.3.5.5 nSLEEP Reset Pulse (HW Variant, LATCHED setting Only)

This is a special communication signal from the controller to the device through the nSLEEP pin available only for the HW variant. This is used to -

- Clear a latched fault when the fault reaction is configured to the LATCHED setting, without forcing the device into SLEEP or affecting any of the other functions (Equivalent to the CLR_FAULT command in the SPI variant)

This pulse on nSLEEP must be greater than the nSLEEP deglitch time of t_{RESET} time, but shorter than t_{SLEEP} time, as shown in case # 3, in Table 7-12 below.

Table 7-12. nSLEEP Timing (HW Variant Only)

Case #	Window Start Time	Window End Time	Command Interpretation	
			Clear Fault	Sleep
1	0	t_{RESET} min	No	No
2	t_{RESET} min	t_{RESET} max	Indeterminate	No
3	t_{RESET} max	t_{SLEEP} min	Yes	No
4	t_{SLEEP} min	t_{SLEEP} max	Yes	Indeterminate
5	t_{SLEEP} max	No limit	Yes	Yes

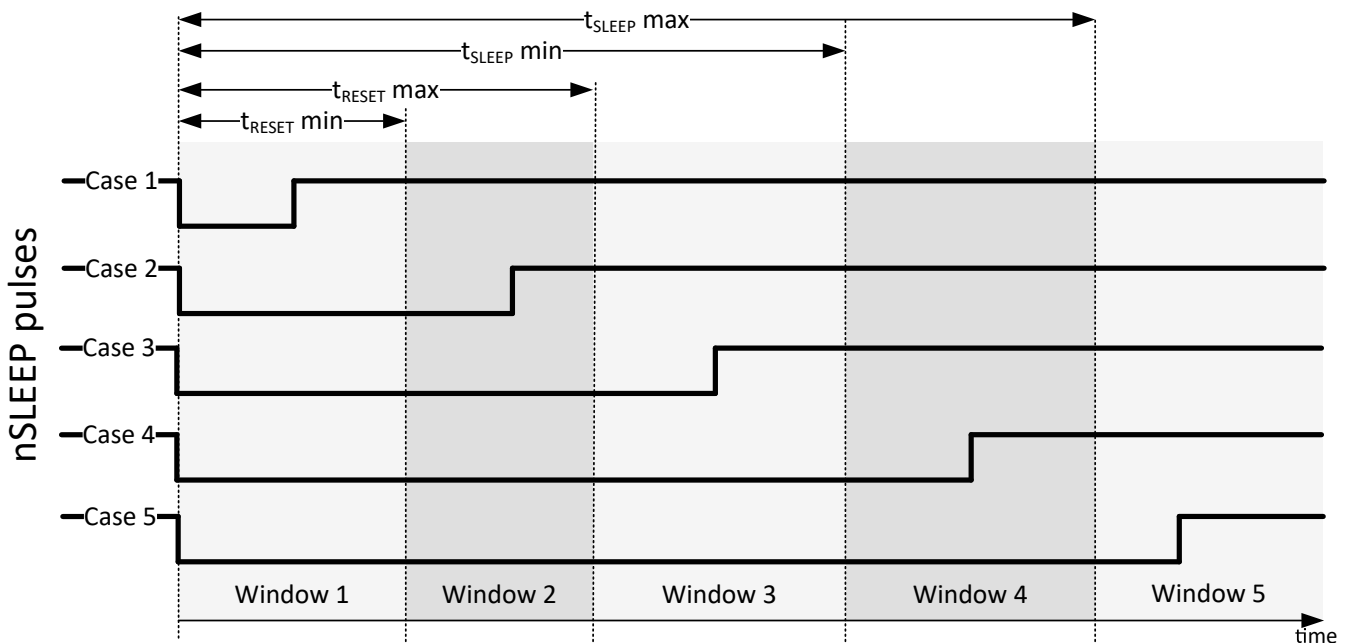

Figure 7-7. nSLEEP Pulse Scenarios

7.3.6 Programming - SPI Variant Only

7.3.6.1 SPI Interface

The SPI variant has full-duplex, 4-wire synchronous communication that is used to set device configurations, operating parameters, and read out diagnostic information from the device. The SPI operates in peripheral mode

and connects to a controller. The serial data input (SDI) word consists of a 16-bit word, with an 8-bit command (A1), followed by 8-bit data (D1). The serial data output (SDO) word consists of the FAULT byte (S1), followed by a report byte (R1). The report byte is either the register data being accessed by read command or null for a write command. The data sequence between the MCU and the SPI peripheral driver is shown in Figure 7-8.

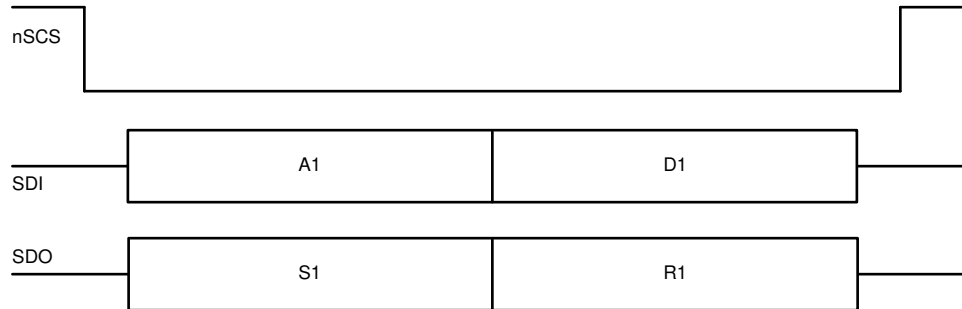

Figure 7-8. SPI Data - Standard "16-bit" Frame

A valid frame must meet the following conditions:

- SCLK pin should be low when the nSCS pin transitions from high to low and from low to high.
- nSCS pin should be pulled high between words.
- When nSCS pin is pulled high, any signals at the SCLK and SDI pins are ignored and the SDO pin is placed in the Hi-Z state.
- Data on SDO from the device is propagated on the rising edge of SCLK, while data on SDI is captured by the device on the subsequent falling edge of SCLK.
- The most significant bit (MSB) is shifted in and out first.
- A full 16 SCLK cycles must occur for a valid transaction for a standard frame, or alternately, for a daisy chain frame with "n" number of peripheral devices, 16 + (n x 16) SCLK cycles must occur for a valid transaction. Else, a frame error (ERR) is reported and the data is ignored if it is a WRITE operation.

7.3.6.2 Standard Frame

The SDI input data word is 2 bytes long and consists of the following format:

- Command byte (first byte)
 - MSB bit indicates frame type (bit B15 = 0 for standard frame).
 - Next to MSB bit, W0, indicates read or write operation (bit B14, write = 0, read = 1)
 - Followed by 6 address bits, A[5:0] (bits B13 through B8)
- Data byte (second byte)
 - Second byte indicates data, D[7:0] (bits B7 through B0). For a read operation, these bits are typically set to null values, while for a write operation, these bits have the data value for the addressed register.

Table 7-13. SDI - Standard Frame Format

	Command Byte								Data Byte							
Bit	B15	B14	B13	B12	B11	B10	B9	B8	B7	B6	B5	B4	B3	B2	B1	B0
Data	0	W0	A5	A4	A3	A2	A1	A0	D7	D6	D5	D4	D3	D2	D1	D0

The SDO output data word is 2 bytes long and consists of the following format:

- Status byte (first byte)
 - 2 MSB bits are forced high (B15, B14 = 1)
 - Following 6 bits are from the FAULT register (B13:B8)
- Report byte (second byte)
 - The second byte (B7:B0) is either the data currently in the register being read for a read operation (W0 = 1), or, existing data in the register being written to for a write command (W0 = 0)

Table 7-14. SDO - Standard Frame Format

Bit	Status Byte								Report Byte							
	B15	B14	B13	B12	B11	B10	B9	B8	B7	B6	B5	B4	B3	B2	B1	B0
Data	1	1	FAULT	VMOV	VMUV	OCF	TSD	ERR	D7	D6	D5	D4	D3	D2	D1	D0

7.3.6.3 SPI Interface for Multiple Peripherals

Multiple devices can be connected to the controller with and without the daisy chain. For connecting a 'n' number of devices to a controller without using a daisy chain, 'n' number of I/O resources from controller has to be utilized for nSCS pins as shown in Figure 7-9. Whereas, if the daisy chain configuration is used, then a single nSCS line can be used for connecting multiple devices, as shown in Figure 7-10.

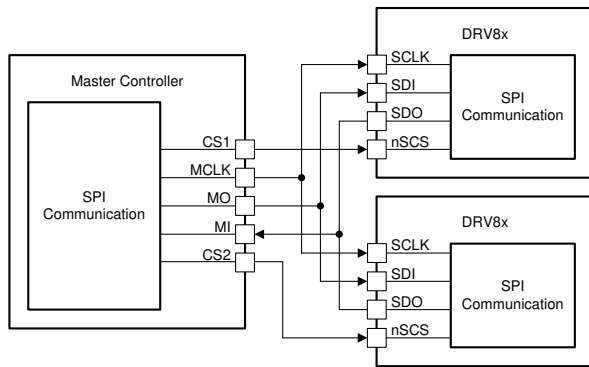

Figure 7-9. SPI Operation Without Daisy Chain

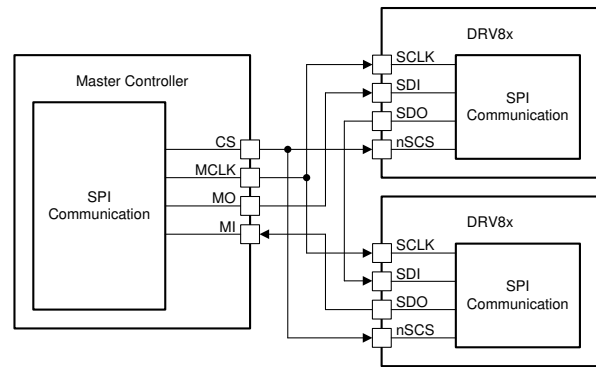

Figure 7-10. SPI Operation With Daisy Chain

7.3.6.3.1 Daisy Chain Frame for Multiple Peripherals

The device can be connected in a daisy chain configuration to save GPIO ports when multiple devices are communicating to the same MCU. Figure 7-11 shows the topology with waveforms, where, number of peripherals connected in a daisy chain "n" is set to 3. A maximum of up to 63 devices can be connected in this manner.

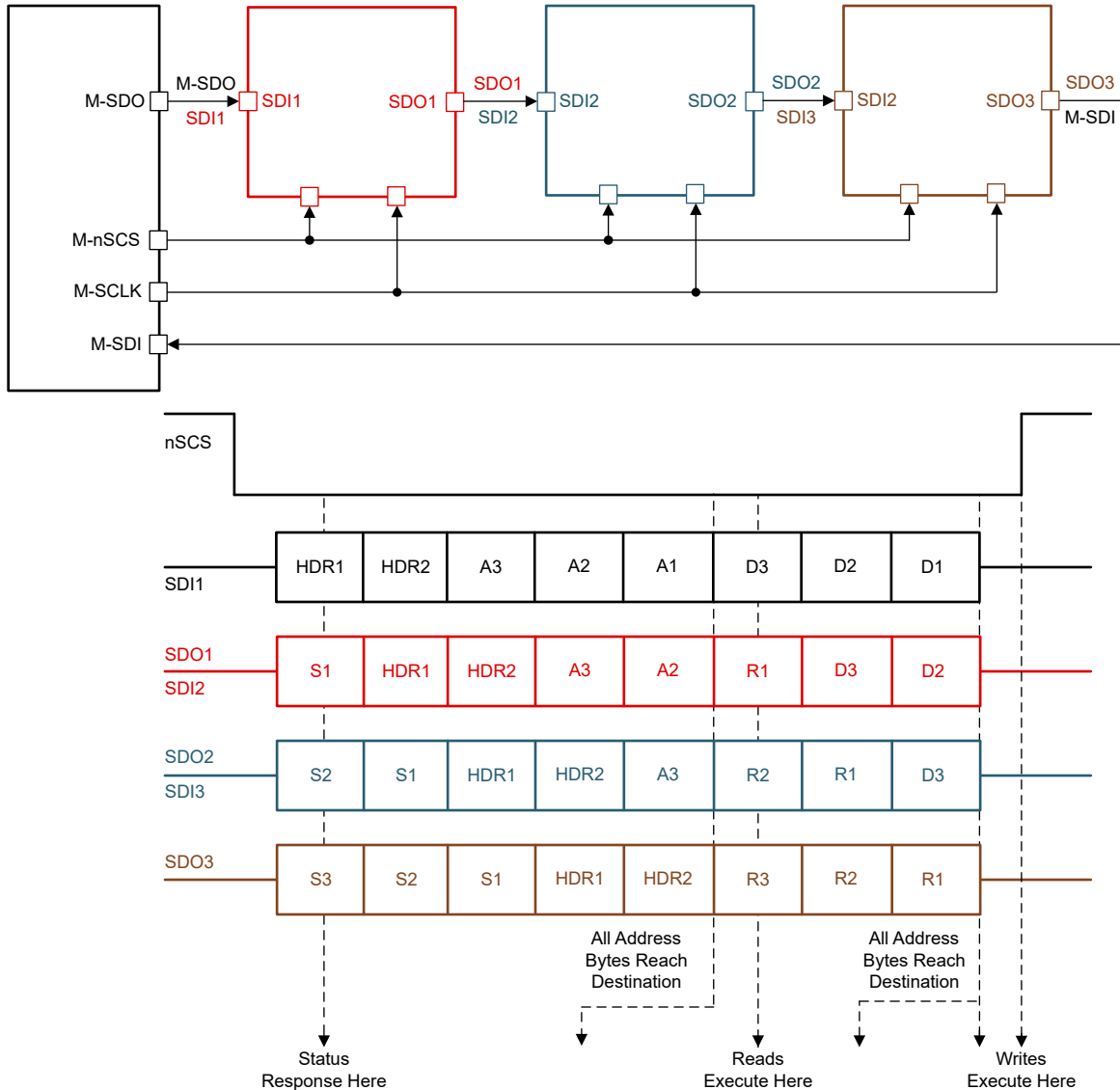

Figure 7-11. Daisy Chain SPI Operation

The SDI sent by the controller in this case would be in the following format (see SDI1 in [Figure 7-11](#)):

- 2 bytes of header (HDR1, HDR2)
- "n" bytes of command byte starting with furthest peripheral in the chain (for this example, this is A3, A2, A1)
- "n" bytes of data byte starting with furthest peripheral in the chain (for this example, this is D3, D2, D1)
- Total of $2 \times "n" + 2$ bytes

While the data is being transmitted through the chain, the controller receives it in the following format (see SDO3 in [Figure 7-11](#)):

- 3 bytes of status byte starting with furthest peripheral in the chain (for this example, this is S3, S2, S1)
- 2 bytes of header that were transmitted before (HDR1, HDR2)
- 3 bytes of report byte starting with furthest peripheral in the chain (for this example, this is R3, R2, R1)

The Header bytes are special bytes asserted at the beginning of a daisy chain SPI communication. **Header bytes must start with 1 and 0 for the two leading bits.**

The first header byte (HDR1) contains information of the total number of peripheral devices in the daisy chain. N5 through N0 are 6 bits dedicated to show the number of device in the chain as shown in [Figure 7-12](#). Up to

63 devices can be connected in series per daisy chain connection. Number of peripheral = 0 is not permitted and will result in a ERR flag.

The second header byte (HDR2) contains a global CLR_FAULT command that will clear the fault registers of all the devices on the rising edge of the chip select (nSCS) signal. The 5 trailing bits of the HDR2 register are marked as SPARE (don't care bits). These can be used by the MCU to determine integrity of the daisy chain connection.

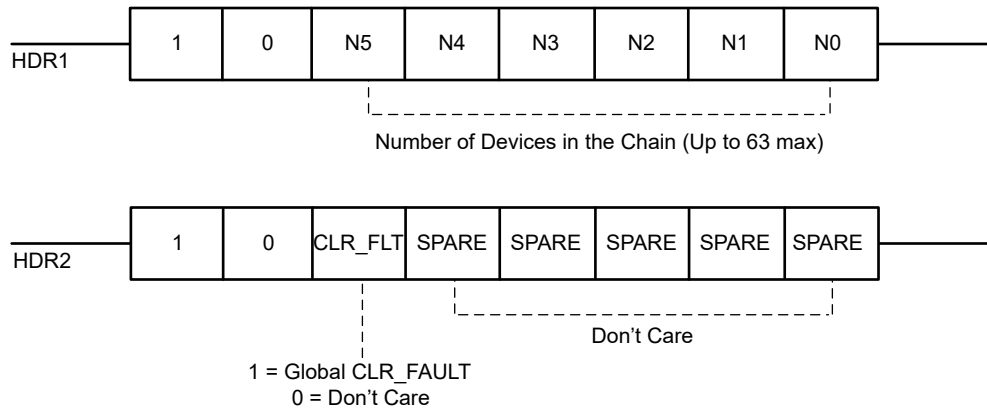

Figure 7-12. Header bytes

In addition, the device recognizes bytes that start with 1 and 1 for the two leading bits as a "pass" byte. These "pass" bytes are NOT processed by the device, but they are simply transmitted out on SDO in the following byte.

When data passes through a device, it determines the position of itself in the chain by counting the number of Status bytes it receives following by the first Header byte. For example, in this 3 device configuration, device 2 in the chain will receive one status byte before receiving the two header bytes.

From the one status byte it knows that its position is second in the chain, and from HDR1 byte it knows how many devices are connected in the chain. That way it only loads the relevant address and data byte in its buffer and bypasses the other bits. This protocol allows for faster communication without adding latency to the system for up to 63 devices in the chain.

The command, data, status and report bytes remain the same as described in the standard frame format.

7.3.7 Register Map - SPI Variant Only

This section describes the user configurable registers in the device.

Note

While the device allows register writes at any time SPI communication is available, it is recommended to exercise caution while updating registers in the ACTIVE state while the load is being driven. This is especially important for settings such as S_DIAG which control the critical device configuration. In order to prevent accidental register writes, the device offers a locking mechanism through the REG_LOCK bits in the COMMAND register to lock the contents of all configurable registers. Best practice would be to write all the configurable registers during initialization and then lock these settings. Run-time register writes for output control are handled by the SPI_IN register, which offers its own separate locking mechanism through the SPI_IN_LOCK bits.

7.3.7.1 User Registers

The following table lists all the registers that can be accessed by the user. All register addresses NOT listed in this table should be considered as "reserved" locations and access is blocked to this space. Accessing them will cause a ERR.

Table 7-15. User Registers

Name	Bit 7	Bit 6	Bit 5	Bit 4	Bit 3	Bit 2	Bit 1	Bit 0	Type ⁽¹⁾
DEVICE_ID	DEV_ID[5:0]					REV_ID[1:0]			R
FAULT	ERR ⁽²⁾	POR	FAULT	VMOV	VMUV	OCP	TSD	OLA ⁽²⁾	R
STATUS1	OLA ⁽³⁾	OLA ⁽³⁾	ITRIP_CMP	ACTIVE	OCP_H ⁽⁵⁾	OCP_L ⁽⁴⁾	OCP_H ⁽⁵⁾	OCP_L ⁽⁴⁾	R
STATUS2	DRV_STAT	RSVD	OTW	ACTIVE	RSVD			OLP_CMP	R
COMMAND	CLR_FLT	RSVD		SPI_IN_LOCK[1:0]		RSVD	REG_LOCK[1:0]		R/W
SPI_IN	RSVD				S_DRVOFF	RSVD	RSVD	S_IN	R/W
CONFIG1	EN_OLA	OTW_SEL	OVSEL	SSC_DIS	OCP_RTRY	TSD_RTRY	OV_RTRY	OLA_RTRY	R/W
CONFIG2	RSVD	S_DIAG[1:0]		ISEL[1:0]		S_ITRIP[2:0]			R/W
CONFIG3	TOFF[1:0]		RSVD	TBLK	SR[1:0]		RSVD		R/W
CONFIG4	OTW_REP	TOCP	OLA_FLTR	OCP_SEL[1:0]		DRV_SEL	RSVD	IN_SEL	R/W

- (1) R = Read Only, R/W = Read/Write
- (2) OLA replaced by ERR in the first SDO byte response, common to all SPI frames. Refer [SDO - Standard frame format](#).
- (3) OLA is indicated if either of the two OLA bits is set
- (4) OCP_L is indicated if either of the two OCP_L bits is set
- (5) OCP_H is indicated if either of the two OCP_H bits is set

ADVANCE INFORMATION

7.3.7.1.1 DEVICE_ID register (Address = 00h)

Return to the [User Register table](#).

Device	DEVICE_ID value
DRV8163S-Q1	0 x 3C

7.3.7.1.2 FAULT Register (Address = 01h) [reset = 40h]

Return to the [User Register table](#).

Bit	Field	Type	Reset	Description
7	ERR	R	0b	1b indicates that a SPI communication fault has occurred in the previous SPI frame.
6	POR	R	1b	1b indicates that a power-on-reset has been detected.
5	FAULT	R	0b	Logic OR of ERR, POR, VMUV, OCP & TSD
4	VMOV	R	0b	1b indicates that a VM over voltage has been detected.
3	VMUV	R	0b	1b indicates that a VM under voltage has been detected.
2	OCP	R	0b	1b indicates that an over current has been detected in either one or more power FETs. Refer OCP_SEL, TOCP to change thresholds & filter times. Refer OCP_RETRY to configure fault reaction.
1	TSD	R	0b	1b indicates that an over temperature has been detected. Refer TSD_RETRY to configure fault reaction.
0	OLA	R	0b	1b indicates that an open load condition has been detected in the ACTIVE state. Refer to EN_OLA to disable diagnostic, OLA_RETRY to configure fault reaction.

7.3.7.1.3 STATUS1 Register (Address = 02h) [reset = 00h]

Return to the [User Register table](#).

Bit	Field	Type	Reset	Description
7	OLA	R	0b	1b indicates that an open load condition has been detected in the ACTIVE state on OUT
6	OLA	R	0b	1b indicates that an open load condition has been detected in the ACTIVE state on OUT
5	ITRIP_CMP	R	0b	1b indicates that load current has reached the ITRIP regulation level.
4	ACTIVE	R	0b	1b indicates that the device is in the ACTIVE state
3	OCP_H	R	0b	1b indicates that an over current has been detected on the high-side FET (short to GND) on OUT
2	OCP_L	R	0b	1b indicates that an over current has been detected on the low-side FET (short to VM) on OUT
1	OCP_H	R	0b	1b indicates that an over current has been detected on the high-side FET (short to GND) on OUT
0	OCP_L	R	0b	1b indicates that an over current has been detected on the low-side FET (short to VM) on OUT

7.3.7.1.4 STATUS2 Register (Address = 03h) [reset = 82h]

Return to the [User Register table](#).

Bit	Field	Type	Reset	Description
7	DRV_STAT	R	1b	This bit shows the status of the DRVOFF pin. 1b implies the pin status is high.

Bit	Field	Type	Reset	Description
6	RSVD	R	0b	Reserved
5	OTW	R	0b	1b indicates that a over temperature warning event has been detected.
4	ACTIVE	R	0b	1b indicates that the device is in the ACTIVE state (Copy of bit4 in STATUS1)
3-1	RSVD	R	000b	Reserved
0	OLP_CMP	R	0b	This bit is the output of the off-state diagnostics (OLP) comparator.

7.3.7.1.5 COMMAND Register (Address = 08h) [reset = 09h]

Return to the [User Register table](#).

Bit	Field	Type	Reset	Description
7	CLR_FLT	R/W	0b	Clear Fault command - Write 1b to clear all faults reported in the fault registers and de-assert the nFAULT pin
6-5	RSVD	R	00b	Reserved
4-3	SPI_IN_LOCK	R/W	01b	<ul style="list-style-type: none"> Write 10b to unlock the SPI_IN register Write 01b or 00b or 11b to lock the SPI_IN register SPI_IN register is locked by default.
2	RSVD	R	0b	Reserved
1-0	REG_LOCK	R/W	01b	<ul style="list-style-type: none"> Write 10b to lock the CONFIG registers Write 01b or 00b or 11b to unlock the CONFIG registers CONFIG registers are unlocked by default.

7.3.7.1.6 SPI_IN Register (Address = 09h) [reset = 0Ch]

Return to the [User Register table](#).

Bit	Field	Type	Reset	Description
7-4	RSVD	R	0000b	Reserved
3	S_DRVOFF	R/W	1b	Register bit equivalent of DRVOFF pin when SPI_IN is unlocked. Refer Register Pin control section.
2-1	RSVD	R	10b	Reserved
0	S_IN	R/W	0b	Register bit equivalent of IN pin when SPI_IN is unlocked. Refer Register Pin control section

7.3.7.1.7 CONFIG1 Register (Address = 0Ah) [reset = 10h]

Return to the [User Register table](#).

Bit	Field	Type	Reset	Description
7	EN_OLA	R/W	0b	Write 1b to enable open load detection in the active state. In Independent mode, OLA is always disabled for low-side load. Refer DIAG section.
6	OTW_SEL	R/W	0b	Over Temperature Warning threshold 0b = 140 °C 1b = 120 °C
5	OVSEL	R/W	0b	0b: VMOV enabled 1b: VMOV disabled

Bit	Field	Type	Reset	Description
4	SSC_DIS	R/W	1b	0b: Enables the spread spectrum clocking feature
3	OCP_RTRY	R/W	0b	Write 1b to configure fault reaction to retry setting on the detection of over current, else the fault reaction is latched
2	TSD_RTRY	R/W	0b	Write 1b to configure fault reaction to retry setting on the detection of over temperature, else the fault reaction is latched
1	OV_RTRY	R/W	0b	Write 1b to configure fault reaction to retry setting on the detection of VMOV, else the fault reaction is latched. This bit also controls the fault reaction for a VM under voltage detection.
0	OLA_RTRY	R/W	0b	Write 1b to configure fault reaction to retry setting on the detection of open load during active, else the fault reaction is latched.

7.3.7.1.8 CONFIG2 Register (Address = 0Bh) [reset = 18h]

Return to the [User Register table](#).

Bit	Field	Type	Reset	Description
7	RSVD	R	0b	Reserved
6-5	S_DIAG	R/W	00b	Load type indication - refer to
4-3	ISEL	R/W	11b	Selects between proportional current output and Die temperature readout voltage.
2-0	S_ITRIP	R/W	000b	ITRIP level configuration - refer ITRIP table

7.3.7.1.9 CONFIG3 Register (Address = 0Ch) [reset = 40h]

Return to the [User Register table](#).

Bit	Field	Type	Reset	Description
7-6	TOFF	R/W	01b	TOFF time used for ITRIP current regulation 00b = 20 μ sec 01b = 30 μ sec 10b = 40 μ sec 11b = 50 μ sec
5	RSVD	R	1b	Reserved.
4	TBLK	R/W	0b	Blanking time configuration 0b = 2.4 μ sec 1b = 3.4 μ sec
3-2	SR	R/W	00b	Slew Rate configuration 00b = 220 V/ μ s 01b = 110 V/ μ s 10b = 50 V/ μ s 11b = 20 V/ μ s
1-0	RSVD	R	10b	Reserved

7.3.7.1.10 CONFIG4 Register (Address = 0Dh) [reset = 44h]

 Return to the [User Register table](#).

Bit	Field	Type	Reset	Description
7	OTW_REP	R/W	0b	0b = Over temperature warning is not reported on nFAULT 1b = Over temperature warning is reported on nFAULT
6	TOCP	R/W	1b	Filter time for over current detection configuration 0b = 1 μ sec 1b = 2 μ sec
5	OLA_FLTR	R/W	0b	Selects OLA filter count. 0b = 16 count, 1b = 1024 count.
4-3	OCP_SEL	R/W	11b	Threshold for over current detection configuration
2	DRV_SEL	R/W	1b	DRVOFF pin - register logic combination, when SPI_IN is unlocked 0b = OR 1b = AND
1	RSVD	R/W	0b	Reserved
0	IN_SEL	R/W	0b	IN pin - register logic combination, when SPI_IN is unlocked 0b = OR 1b = AND

8 Register Map - SPI Variant Only

This section describes the user configurable registers in the device.

Note

While the device allows register writes at any time SPI communication is available, it is recommended to exercise caution while updating registers in the ACTIVE state while the load is being driven. This is especially important for settings such as S_DIAG which control the critical device configuration. In order to prevent accidental register writes, the device offers a locking mechanism through the REG_LOCK bits in the **COMMAND** register to lock the contents of all configurable registers. Best practice would be to write all the configurable registers during initialization and then lock these settings. Run-time register writes for output control are handled by the **SPI_IN** register, which offers its own separate locking mechanism through the SPI_IN_LOCK bits.

8.1 User Registers

The following table lists all the registers that can be accessed by the user. All register addresses NOT listed in this table should be considered as "reserved" locations and access is blocked to this space. Accessing them will cause a ERR.

Table 8-1. User Registers

Name	Bit 7	Bit 6	Bit 5	Bit 4	Bit 3	Bit 2	Bit 1	Bit 0	Type ⁽¹⁾
DEVICE_ID	DEV_ID[5:0]						REV_ID[1:0]		R
FAULT	ERR ⁽²⁾	POR	FAULT	VMOV	VMUV	OCP	TSD	OLA ⁽²⁾	R
STATUS1	OLA ⁽³⁾	OLA ⁽³⁾	ITRIP_CMP	ACTIVE	OCP_H ⁽⁵⁾	OCP_L ⁽⁴⁾	OCP_H ⁽⁵⁾	OCP_L ⁽⁴⁾	R
STATUS2	DRV_STAT	RSVD	OTW	ACTIVE	RSVD			OLP_CMP	R
COMMAND	CLR_FLT	RSVD		SPI_IN_LOCK[1:0]		RSVD	REG_LOCK[1:0]		R/W
SPI_IN	RSVD				S_DRVOFF	RSVD	RSVD	S_IN	R/W
CONFIG1	EN_OLA	OTW_SEL	OVSEL	SSC_DIS	OCP_RTRY	TSD_RTRY	OV_RTRY	OLA_RTRY	R/W
CONFIG2	RSVD	S_DIAG[1:0]		ISEL[1:0]		S_ITRIP[2:0]			R/W
CONFIG3	TOFF[1:0]		RSVD	TBLK	SR[1:0]		RSVD		R/W
CONFIG4	OTW_REP	TOCP	OLA_FLTR	OCP_SEL[1:0]		DRV_SEL	RSVD	IN_SEL	R/W

- (1) R = Read Only, R/W = Read/Write
- (2) OLA replaced by ERR in the first SDO byte response, common to all SPI frames. Refer [SDO - Standard frame format](#).
- (3) OLA is indicated if either of the two OLA bits is set
- (4) OCP_L is indicated if either of the two OCP_L bits is set
- (5) OCP_H is indicated if either of the two OCP_H bits is set

8.1.1 DEVICE_ID register (Address = 00h)

 Return to the [User Register table](#).

Device	DEVICE_ID value
DRV8163S-Q1	0 x 3C

8.1.2 FAULT Register (Address = 01h) [reset = 40h]

 Return to the [User Register table](#).

Bit	Field	Type	Reset	Description
7	ERR	R	0b	1b indicates that a SPI communication fault has occurred in the previous SPI frame.
6	POR	R	1b	1b indicates that a power-on-reset has been detected.
5	FAULT	R	0b	Logic OR of ERR, POR, VMUV, OCP & TSD
4	VMOV	R	0b	1b indicates that a VM over voltage has been detected.
3	VMUV	R	0b	1b indicates that a VM under voltage has been detected.
2	OCP	R	0b	1b indicates that an over current has been detected in either one or more power FETs. Refer OCP_SEL, TOCP to change thresholds & filter times. Refer OCP_RETRY to configure fault reaction.
1	TSD	R	0b	1b indicates that an over temperature has been detected. Refer TSD_RETRY to configure fault reaction.
0	OLA	R	0b	1b indicates that an open load condition has been detected in the ACTIVE state. Refer to EN_OLA to disable diagnostic, OLA_RETRY to configure fault reaction.

8.1.3 STATUS1 Register (Address = 02h) [reset = 00h]

 Return to the [User Register table](#).

Bit	Field	Type	Reset	Description
7	OLA	R	0b	1b indicates that an open load condition has been detected in the ACTIVE state on OUT
6	OLA	R	0b	1b indicates that an open load condition has been detected in the ACTIVE state on OUT
5	ITRIP_CMP	R	0b	1b indicates that load current has reached the ITRIP regulation level.
4	ACTIVE	R	0b	1b indicates that the device is in the ACTIVE state
3	OCP_H	R	0b	1b indicates that an over current has been detected on the high-side FET (short to GND) on OUT
2	OCP_L	R	0b	1b indicates that an over current has been detected on the low-side FET (short to VM) on OUT
1	OCP_H	R	0b	1b indicates that an over current has been detected on the high-side FET (short to GND) on OUT
0	OCP_L	R	0b	1b indicates that an over current has been detected on the low-side FET (short to VM) on OUT

8.1.4 STATUS2 Register (Address = 03h) [reset = 82h]

 Return to the [User Register table](#).

Bit	Field	Type	Reset	Description
7	DRV_STAT	R	1b	This bit shows the status of the DRVOFF pin. 1b implies the pin status is high.

Bit	Field	Type	Reset	Description
6	RSVD	R	0b	Reserved
5	OTW	R	0b	1b indicates that a over temperature warning event has been detected.
4	ACTIVE	R	0b	1b indicates that the device is in the ACTIVE state (Copy of bit4 in STATUS1)
3-1	RSVD	R	000b	Reserved
0	OLP_CMP	R	0b	This bit is the output of the off-state diagnostics (OLP) comparator.

8.1.5 COMMAND Register (Address = 08h) [reset = 09h]

Return to the [User Register table](#).

Bit	Field	Type	Reset	Description
7	CLR_FLT	R/W	0b	Clear Fault command - Write 1b to clear all faults reported in the fault registers and de-assert the nFAULT pin
6-5	RSVD	R	00b	Reserved
4-3	SPI_IN_LOCK	R/W	01b	<ul style="list-style-type: none"> Write 10b to unlock the SPI_IN register Write 01b or 00b or 11b to lock the SPI_IN register SPI_IN register is locked by default.
2	RSVD	R	0b	Reserved
1-0	REG_LOCK	R/W	01b	<ul style="list-style-type: none"> Write 10b to lock the CONFIG registers Write 01b or 00b or 11b to unlock the CONFIG registers CONFIG registers are unlocked by default.

8.1.6 SPI_IN Register (Address = 09h) [reset = 0Ch]

Return to the [User Register table](#).

Bit	Field	Type	Reset	Description
7-4	RSVD	R	0000b	Reserved
3	S_DRVOFF	R/W	1b	Register bit equivalent of DRVOFF pin when SPI_IN is unlocked. Refer Register Pin control section.
2-1	RSVD	R	10b	Reserved
0	S_IN	R/W	0b	Register bit equivalent of IN pin when SPI_IN is unlocked. Refer Register Pin control section

8.1.7 CONFIG1 Register (Address = 0Ah) [reset = 10h]

Return to the [User Register table](#).

Bit	Field	Type	Reset	Description
7	EN_OLA	R/W	0b	Write 1b to enable open load detection in the active state. In Independent mode, OLA is always disabled for low-side load. Refer DIAG section.
6	OTW_SEL	R/W	0b	Over Temperature Warning threshold 0b = 140 °C 1b = 120 °C
5	OVSEL	R/W	0b	0b: VMOV enabled 1b: VMOV disabled

Bit	Field	Type	Reset	Description
4	SSC_DIS	R/W	1b	0b: Enables the spread spectrum clocking feature
3	OCP_RTRY	R/W	0b	Write 1b to configure fault reaction to retry setting on the detection of over current, else the fault reaction is latched
2	TSD_RTRY	R/W	0b	Write 1b to configure fault reaction to retry setting on the detection of over temperature, else the fault reaction is latched
1	OV_RTRY	R/W	0b	Write 1b to configure fault reaction to retry setting on the detection of VMOV, else the fault reaction is latched. This bit also controls the fault reaction for a VM under voltage detection.
0	OLA_RTRY	R/W	0b	Write 1b to configure fault reaction to retry setting on the detection of open load during active, else the fault reaction is latched.

8.1.8 CONFIG2 Register (Address = 0Bh) [reset = 18h]

Return to the [User Register table](#).

Bit	Field	Type	Reset	Description
7	RSVD	R	0b	Reserved
6-5	S_DIAG	R/W	00b	Load type indication - refer to
4-3	ISEL	R/W	11b	Selects between proportional current output and Die temperature readout voltage.
2-0	S_ITRIP	R/W	000b	ITRIP level configuration - refer ITRIP table

8.1.9 CONFIG3 Register (Address = 0Ch) [reset = 40h]

Return to the [User Register table](#).

Bit	Field	Type	Reset	Description
7-6	TOFF	R/W	01b	TOFF time used for ITRIP current regulation 00b = 20 μ sec 01b = 30 μ sec 10b = 40 μ sec 11b = 50 μ sec
5	RSVD	R	1b	Reserved.
4	TBLK	R/W	0b	Blanking time configuration 0b = 2.4 μ sec 1b = 3.4 μ sec
3-2	SR	R/W	00b	Slew Rate configuration 00b = 220 V/ μ s 01b = 110 V/ μ s 10b = 50 V/ μ s 11b = 20 V/ μ s
1-0	RSVD	R	10b	Reserved

8.1.10 CONFIG4 Register (Address = 0Dh) [reset = 44h]

Return to the [User Register table](#).

Bit	Field	Type	Reset	Description
7	OTW_REP	R/W	0b	0b = Over temperature warning is not reported on nFAULT 1b = Over temperature warning is reported on nFAULT
6	TOCP	R/W	1b	Filter time for over current detection configuration 0b = 1 μ sec 1b = 2 μ sec
5	OLA_FLTR	R/W	0b	Selects OLA filter count. 0b = 16 count, 1b = 1024 count.
4-3	OCP_SEL	R/W	11b	Threshold for over current detection configuration
2	DRV_SEL	R/W	1b	DRVOFF pin - register logic combination, when SPI_IN is unlocked 0b = OR 1b = AND
1	RSVD	R/W	0b	Reserved
0	IN_SEL	R/W	0b	IN pin - register logic combination, when SPI_IN is unlocked 0b = OR 1b = AND

9 Application and Implementation

Note

Information in the following applications sections is not part of the TI component specification, and TI does not warrant its accuracy or completeness. TI's customers are responsible for determining suitability of components for their purposes, as well as validating and testing their design implementation to confirm system functionality.

9.1 Application Information

The DRV8163-Q1 can be used in a variety of applications that require either a half-bridge or H-bridge power stage configuration. Common application examples include brushed DC motors, solenoids, and actuators. The device can also be utilized to drive many common passive loads such as LEDs, resistive elements, relays, etc.

9.1.1 Load Summary

The following table summarizes the utility of the device features for different type of inductive loads.

Table 9-1. Load Summary Table

LOAD	Configuration		Device Feature	
	Device	Recirculation Path	Current sense	ITRIP regulation
Bi-directional motor or solenoid ⁽¹⁾	Full-Bridge with two DRV8163	High-side	Continuous	Not useful ⁽³⁾
Bi-directional motor or solenoid ⁽¹⁾	Full-Bridge with two DRV8163	Low-side	Discontinuous ⁽²⁾	Useful
Uni-directional motor or Low-side solenoid (one side connected to GND)	DRV8163	Low-side	Discontinuous ⁽²⁾	Useful
High-side solenoid (one side connected to VM)	DRV8163	High-side	Not available, need external solution	

- (1) Solenoid - clamping or quick demagnetization possible, but clamping level will be VM dependent
- (2) Not sensed during recirculation and during OUT voltage slew times including t_{blank}
- (3) SPI variant - Controller can poll ITRIP_CMP bit for external coordination between the two Half-Bridges

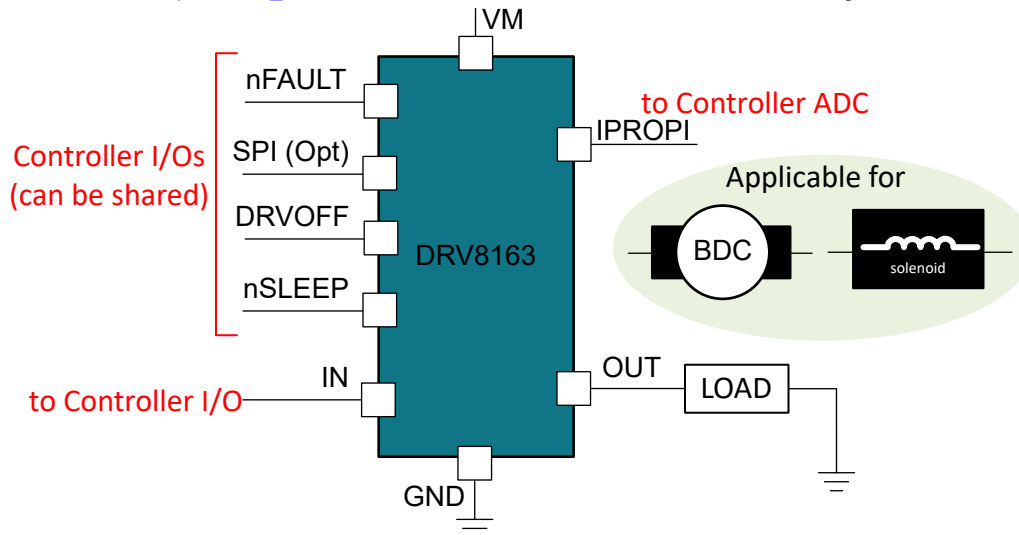

Figure 9-1. Illustration Showing a Half-Bridge Topology to Drive Low-side Load With DRV8163-Q1 Device

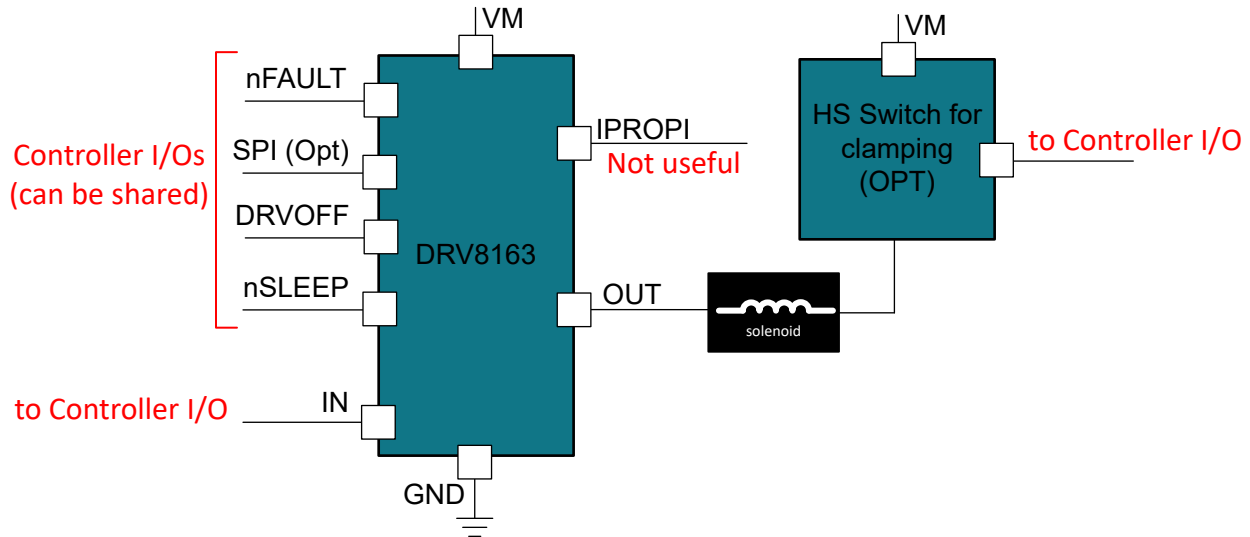

Figure 9-2. Illustration showing a Half-Bridge topology to drive high-side load with DRV8163-Q1 device

9.2 Typical Application

The figures below show the typical application schematic for driving a brushed DC motor or any inductive load. There are several optional connections shown in these schematics, which are listed as follows:

- nSLEEP pin
 - SPI variant - This pin can be tied off high in the application if SLEEP function is not needed.
 - HW variant - Pin control is **mandatory** even if SLEEP function is not needed. The controller needs to issue a [reset pulse](#) during wake-up to acknowledge wake-up or power-up.
- DRVOFF pin
 - SPI variant - This pin can be tied off low in the application if shutoff through [pin](#) function is not needed. The equivalent register bit can be used.
- IN pin
 - SPI variant - This pin can be tied off low or left floating if register only control is needed.
- NC pin
 - All variants - This pin can be left floating or tied off low.
- OUT pin
 - Recommend to add a PCB footprint for capacitor from OUT to GND close to the load for EMC purposes.
- IPROPI pin
 - All variants - Monitoring of this output is optional. Also IPROPI pin can be tied low if ITRIP feature & IPROPI function is not needed. Recommend to add a PCB footprint for a small capacitor (10nF to 100nF) if needed.
- nFAULT pin
 - SPI variant - Monitoring of this output is optional. All diagnostic information can be read from the STATUS registers.
- SPI input pins
 - SPI variant - Inputs (SDI, nSCS, SCLK) are compatible with 3.3V / 5V levels.
- SPI SDO pin
 - SDO tracks the VDD pin voltage. To interface with a 3.3V level controller input, a level shifter or a current limiting series resistor is recommended.
- CONFIG pins
 - HW variant - Resistor is not needed for short to GND and Hi-Z level selections

9.2.1 HW Variant

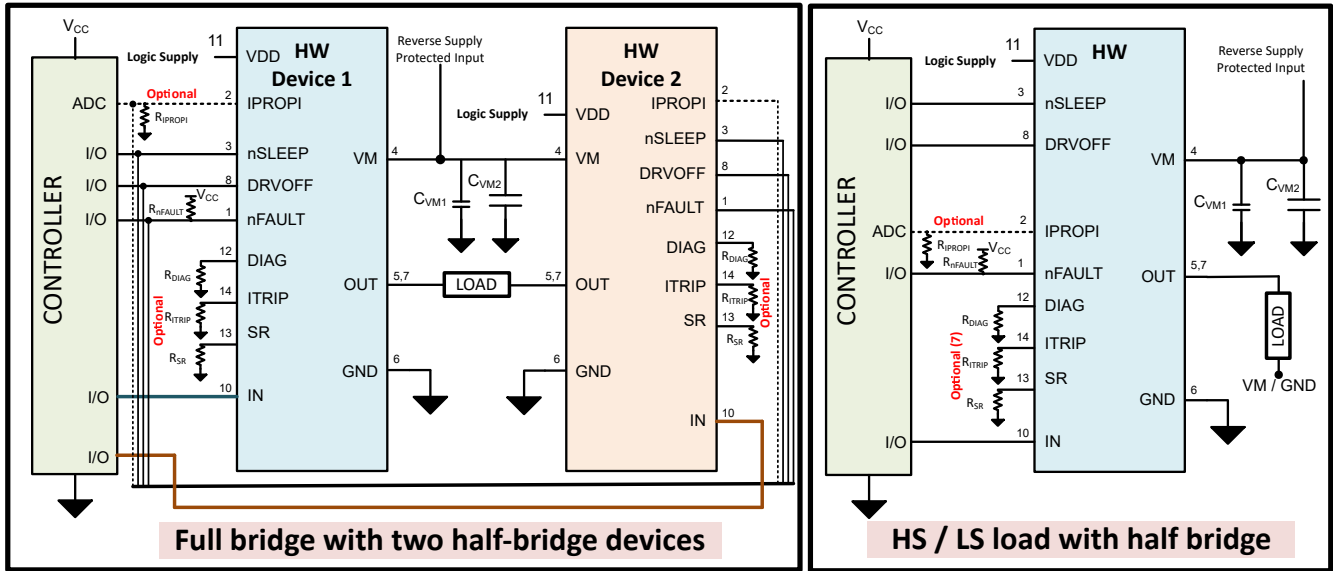

Figure 9-3. Typical Application Schematic - HW Variant

9.2.2 SPI Variant

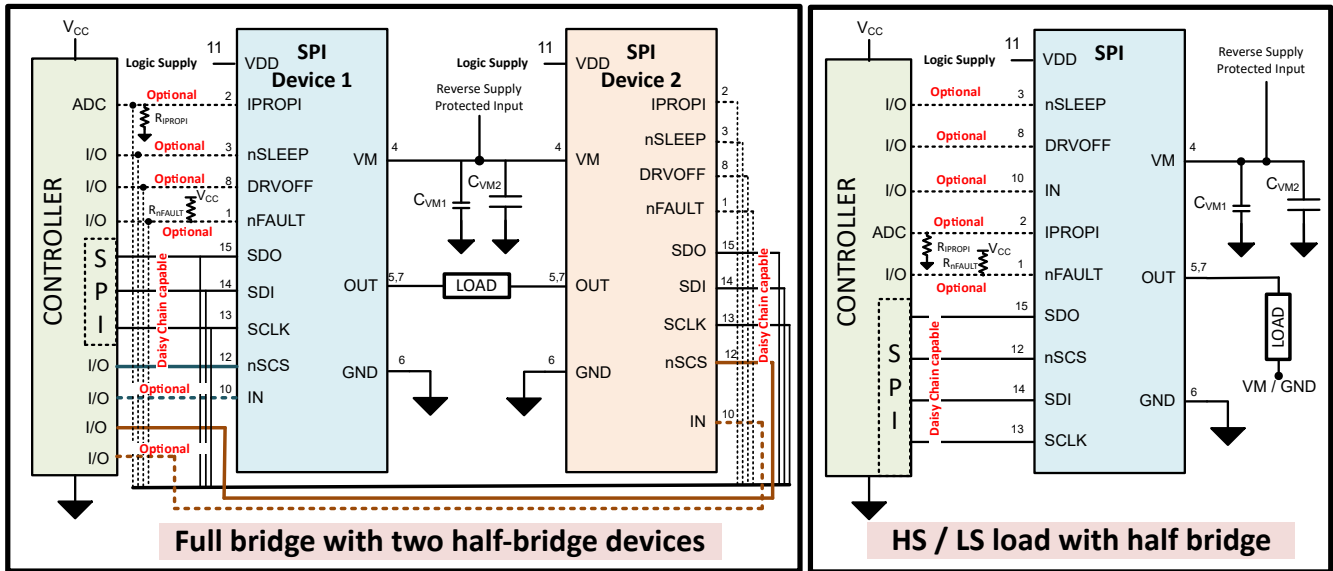

Figure 9-4. Typical Application Schematic - SPI Variant

10 Device and Documentation Support

TI offers an extensive line of development tools. Tools and software to evaluate the performance of the device, generate code, and develop solutions are listed below.

10.1 Device Support

10.2 Documentation Support

10.2.1 Related Documentation

10.3 Receiving Notification of Documentation Updates

To receive notification of documentation updates, navigate to the device product folder on ti.com. Click on *Notifications* to register and receive a weekly digest of any product information that has changed. For change details, review the revision history included in any revised document.

10.4 Support Resources

[TI E2E™ support forums](#) are an engineer's go-to source for fast, verified answers and design help — straight from the experts. Search existing answers or ask your own question to get the quick design help you need.

Linked content is provided "AS IS" by the respective contributors. They do not constitute TI specifications and do not necessarily reflect TI's views; see TI's [Terms of Use](#).

10.5 Trademarks

TI E2E™ is a trademark of Texas Instruments.
All trademarks are the property of their respective owners.

10.6 Electrostatic Discharge Caution



This integrated circuit can be damaged by ESD. Texas Instruments recommends that all integrated circuits be handled with appropriate precautions. Failure to observe proper handling and installation procedures can cause damage.

ESD damage can range from subtle performance degradation to complete device failure. Precision integrated circuits may be more susceptible to damage because very small parametric changes could cause the device not to meet its published specifications.

10.7 Glossary

[TI Glossary](#) This glossary lists and explains terms, acronyms, and definitions.

11 Mechanical, Packaging, and Orderable Information

The following pages include mechanical, packaging, and orderable information. This information is the most current data available for the designated devices. This data is subject to change without notice and revision of this document. For browser-based versions of this data sheet, refer to the left-hand navigation.

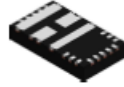

VAK0015A

PACKAGE OUTLINE
VQFN-HR - 1 mm max height

PLASTIC QUAD FLATPACK - NO LEAD

ADVANCE INFORMATION

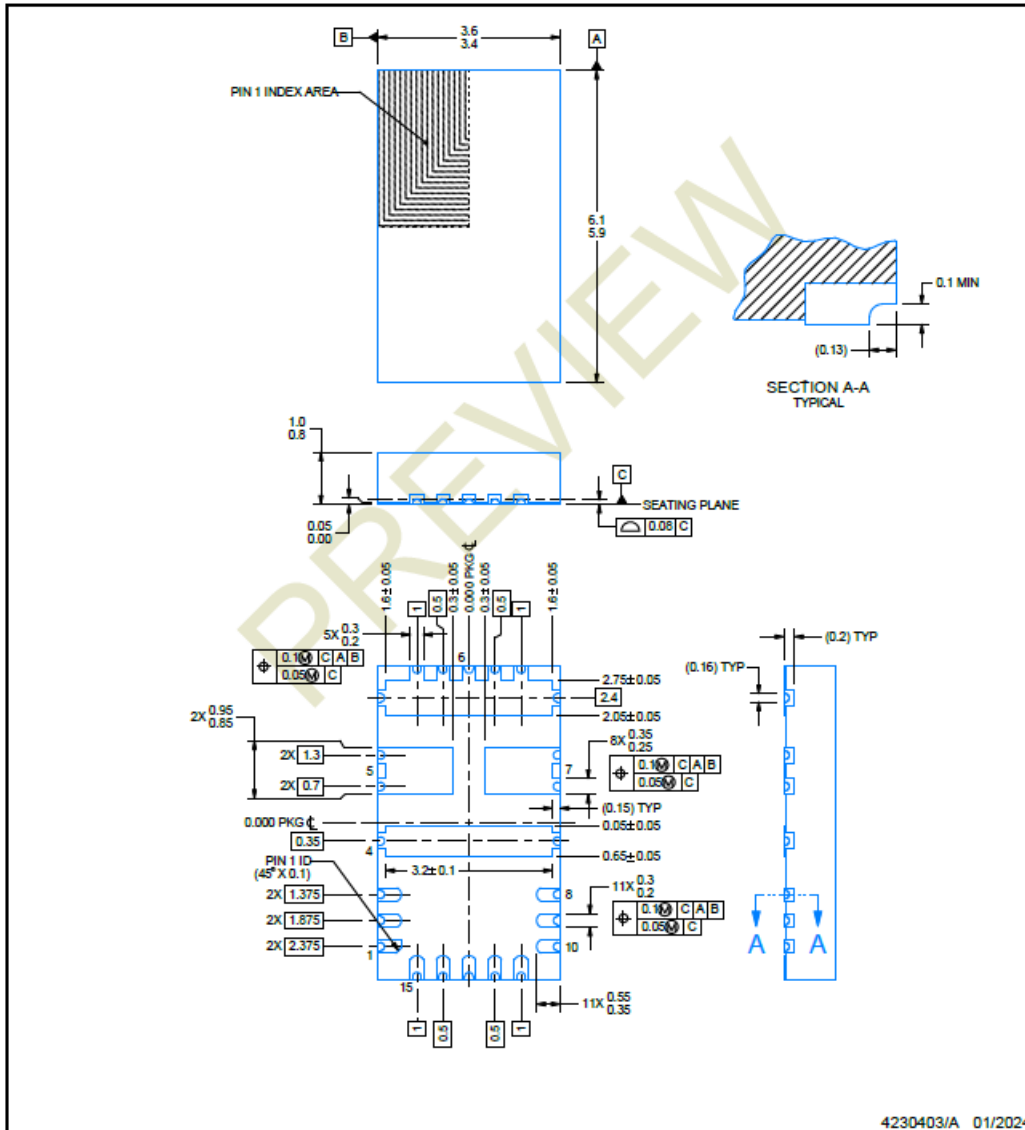

4230403/A 01/2024

NOTES:

1. All linear dimensions are in millimeters. Any dimensions in parenthesis are for reference only. Dimensioning and tolerancing per ASME Y14.5M.
2. This drawing is subject to change without notice.

EXAMPLE BOARD LAYOUT

VAK0015A

VQFN-HR - 1 mm max height

PLASTIC QUAD FLATPACK - NO LEAD

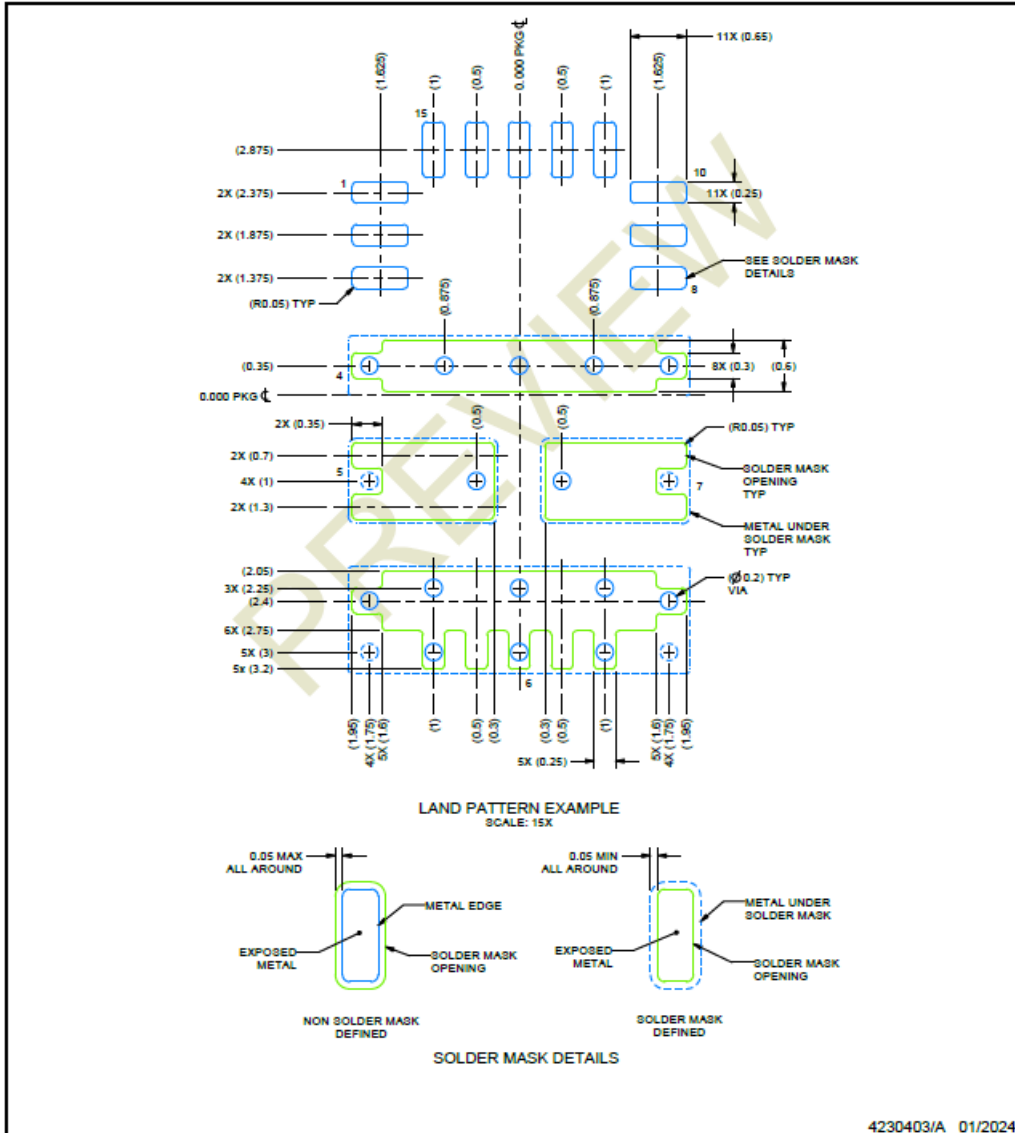

ADVANCE INFORMATION

NOTES: (continued)

- For more information, see Texas Instruments literature number SLUA271 (www.ti.com/lit/slua271).
- Vias are optional depending on application, refer to device data sheet. If any vias are implemented, refer to their locations shown on this view. It is recommended that vias under paste be filled, plugged or tented.

EXAMPLE STENCIL DESIGN

VAK0015A

VQFN-HR - 1 mm max height

PLASTIC QUAD FLATPACK - NO LEAD

ADVANCE INFORMATION

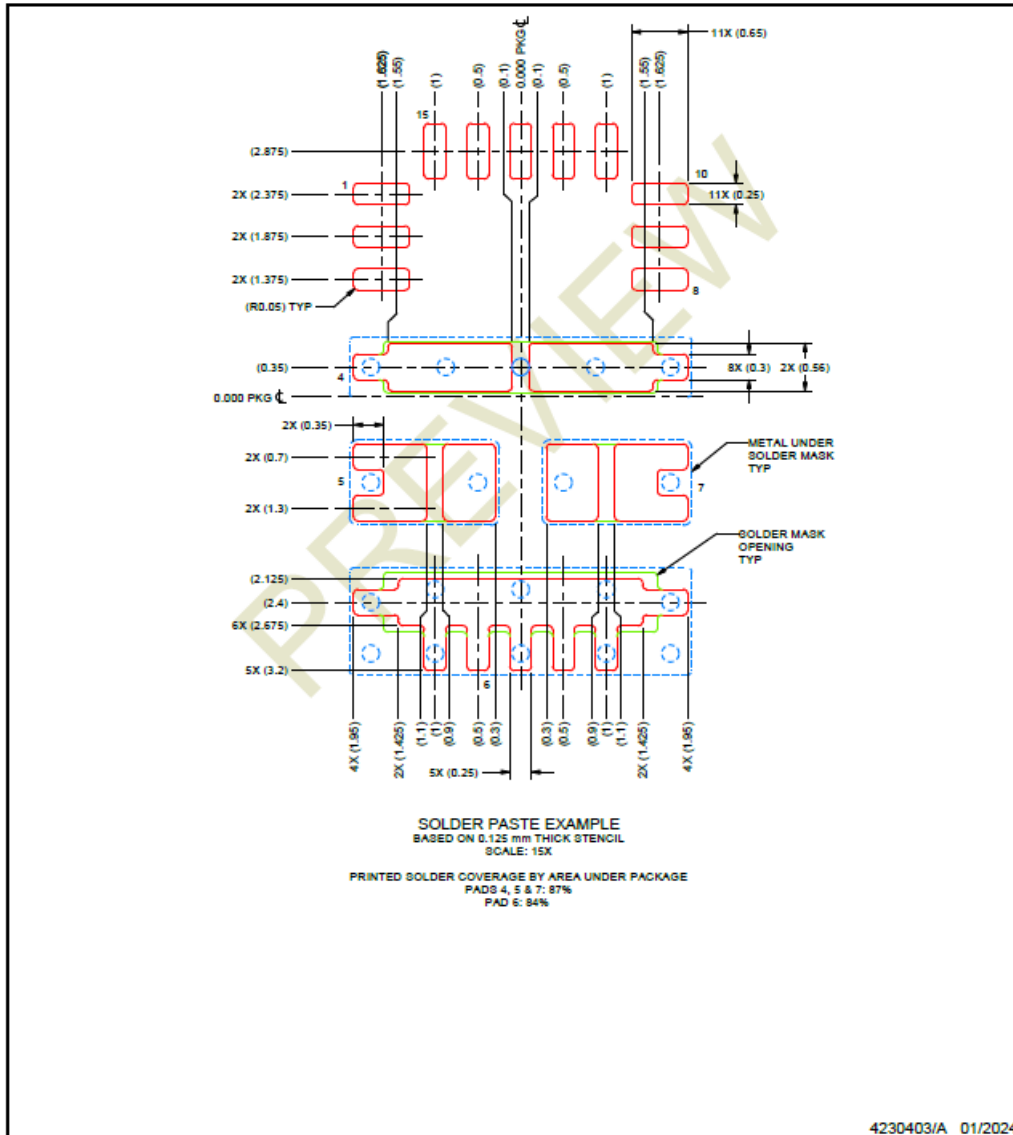

NOTES: (continued)

- 5. Laser cutting apertures with trapezoidal walls and rounded corners may offer better paste release. IPC-7525 may have alternate design recommendations.

PACKAGING INFORMATION

Orderable part number	Status (1)	Material type (2)	Package Pins	Package qty Carrier	RoHS (3)	Lead finish/ Ball material (4)	MSL rating/ Peak reflow (5)	Op temp (°C)	Part marking (6)
PDRV8163HQVAKRQ1	Active	Preproduction	VQFN-HR (VAK) 15	3000 LARGE T&R	-	Call TI	Call TI	120 to -40	
PDRV8163HQVAKRQ1.A	Active	Preproduction	VQFN-HR (VAK) 15	3000 LARGE T&R	-	Call TI	Call TI	120 to -40	
PDRV8163SQVAKRQ1	Active	Preproduction	VQFN-HR (VAK) 15	3000 LARGE T&R	-	Call TI	Call TI	120 to -40	
PDRV8163SQVAKRQ1.A	Active	Preproduction	VQFN-HR (VAK) 15	3000 LARGE T&R	-	Call TI	Call TI	120 to -40	

(1) **Status:** For more details on status, see our [product life cycle](#).

(2) **Material type:** When designated, preproduction parts are prototypes/experimental devices, and are not yet approved or released for full production. Testing and final process, including without limitation quality assurance, reliability performance testing, and/or process qualification, may not yet be complete, and this item is subject to further changes or possible discontinuation. If available for ordering, purchases will be subject to an additional waiver at checkout, and are intended for early internal evaluation purposes only. These items are sold without warranties of any kind.

(3) **RoHS values:** Yes, No, RoHS Exempt. See the [TI RoHS Statement](#) for additional information and value definition.

(4) **Lead finish/Ball material:** Parts may have multiple material finish options. Finish options are separated by a vertical ruled line. Lead finish/Ball material values may wrap to two lines if the finish value exceeds the maximum column width.

(5) **MSL rating/Peak reflow:** The moisture sensitivity level ratings and peak solder (reflow) temperatures. In the event that a part has multiple moisture sensitivity ratings, only the lowest level per JEDEC standards is shown. Refer to the shipping label for the actual reflow temperature that will be used to mount the part to the printed circuit board.

(6) **Part marking:** There may be an additional marking, which relates to the logo, the lot trace code information, or the environmental category of the part.

Multiple part markings will be inside parentheses. Only one part marking contained in parentheses and separated by a "~" will appear on a part. If a line is indented then it is a continuation of the previous line and the two combined represent the entire part marking for that device.

Important Information and Disclaimer: The information provided on this page represents TI's knowledge and belief as of the date that it is provided. TI bases its knowledge and belief on information provided by third parties, and makes no representation or warranty as to the accuracy of such information. Efforts are underway to better integrate information from third parties. TI has taken and continues to take reasonable steps to provide representative and accurate information but may not have conducted destructive testing or chemical analysis on incoming materials and chemicals. TI and TI suppliers consider certain information to be proprietary, and thus CAS numbers and other limited information may not be available for release.

In no event shall TI's liability arising out of such information exceed the total purchase price of the TI part(s) at issue in this document sold by TI to Customer on an annual basis.

IMPORTANT NOTICE AND DISCLAIMER

TI PROVIDES TECHNICAL AND RELIABILITY DATA (INCLUDING DATA SHEETS), DESIGN RESOURCES (INCLUDING REFERENCE DESIGNS), APPLICATION OR OTHER DESIGN ADVICE, WEB TOOLS, SAFETY INFORMATION, AND OTHER RESOURCES "AS IS" AND WITH ALL FAULTS, AND DISCLAIMS ALL WARRANTIES, EXPRESS AND IMPLIED, INCLUDING WITHOUT LIMITATION ANY IMPLIED WARRANTIES OF MERCHANTABILITY, FITNESS FOR A PARTICULAR PURPOSE OR NON-INFRINGEMENT OF THIRD PARTY INTELLECTUAL PROPERTY RIGHTS.

These resources are intended for skilled developers designing with TI products. You are solely responsible for (1) selecting the appropriate TI products for your application, (2) designing, validating and testing your application, and (3) ensuring your application meets applicable standards, and any other safety, security, regulatory or other requirements.

These resources are subject to change without notice. TI grants you permission to use these resources only for development of an application that uses the TI products described in the resource. Other reproduction and display of these resources is prohibited. No license is granted to any other TI intellectual property right or to any third party intellectual property right. TI disclaims responsibility for, and you will fully indemnify TI and its representatives against, any claims, damages, costs, losses, and liabilities arising out of your use of these resources.

TI's products are provided subject to [TI's Terms of Sale](#) or other applicable terms available either on [ti.com](https://www.ti.com) or provided in conjunction with such TI products. TI's provision of these resources does not expand or otherwise alter TI's applicable warranties or warranty disclaimers for TI products.

TI objects to and rejects any additional or different terms you may have proposed.

Mailing Address: Texas Instruments, Post Office Box 655303, Dallas, Texas 75265

Copyright © 2025, Texas Instruments Incorporated