

UCC23113 5-A, 5-A, Opto-Compatible Single-Channel Functional Isolated Gate Driver with UVLO

1 Features

- 1.5-kV_{DC} single channel isolated gate driver with opto-compatible input
- Pin-to-pin, drop in upgrade for opto isolated gate drivers
- 5-A source / 5-A sink, peak output current
- Maximum 30-V output driver supply voltage
- 12-V VDD undervoltage lockout
- Rail-to-rail output
- 105-ns (maximum) propagation delay
- 25-ns (maximum) part-to-part delay matching
- 35-ns (maximum) pulse width distortion
- 100-kV/μs (minimum) common-mode transient immunity (CMTI)
- 5-V reverse polarity voltage handling capability on input stage supporting interlock
- Stretched SO-6 package with >8.5-mm creepage and clearance
- Operating junction temperature, T_J: –40°C to +150°C

2 Applications

- Industrial motor-control drives
- Solar inverters
- Industrial power supplies, UPS
- Induction heating

3 Description

The UCC23113 opto-compatible, single-channel, isolated gate driver for IGBTs, MOSFETs and SiC MOSFETs, with 5-A source and 5-A sink peak output current and 1.5-kV_{DC} functional isolation. The high

supply voltage range of 30 V allows the use of bipolar supplies to effectively drive IGBTs and SiC power FETs. The UCC23113 can drive both low-side and high-side power FETs.

Key features and characteristics bring significant performance and reliability upgrades over standard opto-coupler based gate drivers while maintaining pin-to-pin compatibility in both schematic and layout design. Performance highlights include high common-mode transient immunity (CMTI), low propagation delay, and small pulse width distortion. Tight process control results in small part-to-part skew. The input stage is an emulated diode (e-diode) which means long term reliability and excellent aging characteristics compared to traditional LEDs found in optocoupler gate drivers. It is offered in a stretched SO6 package with >8.5-mm creepage and clearance, and a mold compound from material group I which has a comparative tracking index (CTI) > 600 V.

The high performance and reliability of the UCC23113 makes it ideal for use in all types of motor drives, solar inverters, industrial power supplies, and appliances. The higher operating temperature opens up opportunities for applications not previously able to be supported by traditional optocouplers.

Device Information

PART NUMBER	PACKAGE ⁽¹⁾	UVLO Level
UCC23113CDWYR	Stretched SO-6	12 V

(1) For all available packages, see the orderable addendum at the end of the data sheet.

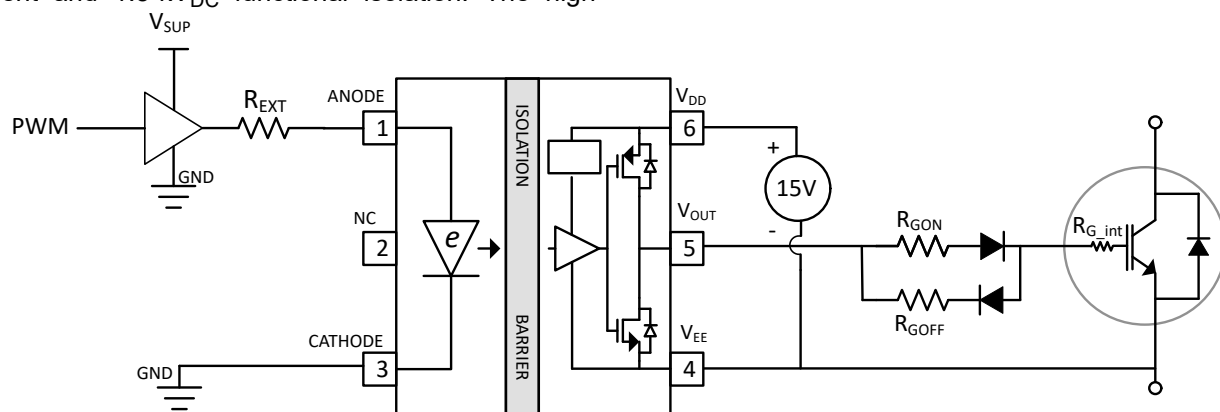

Typical Application Schematic

Table of Contents

1 Features	1	8.2 Functional Block Diagram.....	12
2 Applications	1	8.3 Feature Description.....	13
3 Description	1	8.4 Device Functional Modes.....	17
4 Revision History	2	9 Application and Implementation	18
5 Pin Configuration and Function	3	9.1 Application Information.....	18
6 Specifications	4	9.2 Typical Application.....	19
6.1 Absolute Maximum Ratings.....	4	10 Power Supply Recommendations	24
6.2 ESD Ratings.....	4	11 Layout	25
6.3 Recommended Operating Conditions.....	4	11.1 Layout Guidelines.....	25
6.4 Thermal Information.....	4	11.2 Layout Example.....	26
6.5 Power Ratings.....	5	11.3 PCB Material.....	29
6.6 Insulation Specifications.....	6	12 Device and Documentation Support	30
6.7 Electrical Characteristics.....	7	12.1 Device Support.....	30
6.8 Switching Characteristics.....	7	12.2 Documentation Support.....	30
6.9 Typical Characteristics.....	8	12.3 Receiving Notification of Documentation Updates..	30
7 Parameter Measurement Information	11	12.4 Support Resources.....	30
7.1 Propagation Delay, Rise Time and Fall Time.....	11	12.5 Trademarks.....	30
7.2 I _{OH} and I _{OL} testing.....	11	12.6 Electrostatic Discharge Caution.....	30
7.3 CMTI Testing.....	11	12.7 Glossary.....	30
8 Detailed Description	12	13 Mechanical, Packaging, and Orderable Information	31
8.1 Overview.....	12		

4 Revision History

NOTE: Page numbers for previous revisions may differ from page numbers in the current version.

DATE	REVISION	NOTES
August 2023	*	Initial Release

5 Pin Configuration and Function

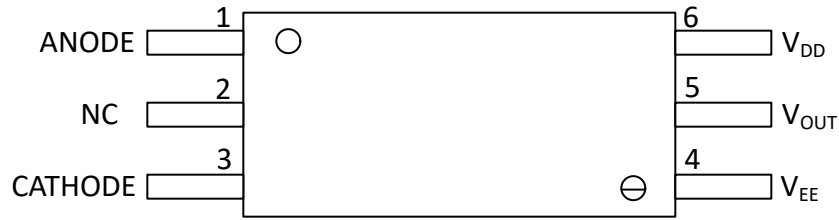

Figure 5-1. UCC23113 DWY Package SOIC-6 Top View

Table 5-1. Pin Functions

PIN		TYPE ⁽¹⁾	DESCRIPTION
NAME	NO.		
ANODE	1	I	Anode
CATHODE	3	I	Cathode
NC	2	-	No Connection
V _{DD}	6	P	Positive output supply rail
V _{EE}	4	P	Negative output supply rail
V _{OUT}	5	O	Gate-drive output

(1) P = Power, G = Ground, I = Input, O = Output

6 Specifications

6.1 Absolute Maximum Ratings

Over operating free air temperature range (unless otherwise noted)⁽¹⁾

		MIN	MAX	UNIT
Average Input Current	$I_{F(AVG)}$	-	25	mA
Peak Transient Input Current	$I_{F(TRAN)} < 1\mu s \text{ pulse, } 300\text{pps}$		1	A
Reverse Input Voltage	$V_{R(MAX)}$		6	V
Output supply voltage	$V_{DD} - V_{EE}$	-0.3	36	V
Output DC Steady State Voltage	$V_{OUT(DC)}$	VEE-0.5	VDD+0.5	V
Output Transient Voltage	$V_{OUT(TRAN)}$	VEE-5	VDD+5	V
Junction temperature	T_J ⁽²⁾	-40	150	°C
Storage temperature	T_{stg}	-65	150	°C
Input-to-output operating voltage	$ V_{IO} $		1500	V_{DC}

- (1) Stresses beyond those listed under *Absolute Maximum Ratings* may cause permanent damage to the device. These are stress ratings only, which do not imply functional operation of the device at these or any other conditions beyond those indicated under *Recommended Operating Conditions*. Exposure to absolute-maximum-rated conditions for extended periods may affect device reliability.
- (2) To maintain the recommended operating conditions for T_J , see [Section 6.4](#).

6.2 ESD Ratings

			VALUE	UNIT
$V_{(ESD)}$	Electrostatic discharge	Human body model (HBM), per ANSI/ESDA/JEDEC JS-001 ⁽¹⁾	±2000	V
		Charged device model (CDM), per JEDEC specification JESD22-C101 ⁽²⁾	±500	

- (1) JEDEC document JEP155 states that 500-V HBM allows safe manufacturing with a standard ESD control process.
- (2) JEDEC document JEP157 states that 250-V CDM allows safe manufacturing with a standard ESD control process.

6.3 Recommended Operating Conditions

Over operating free-air temperature range (unless otherwise noted)

		MIN	NOM	MAX	UNIT
VDD	Output Supply Voltage($V_{DD} - V_{EE}$) - 12V UVLO	13		30	V
I_F (ON)	Input Diode Forward Current (Diode "ON")	7		16	mA
V_F (OFF)	Anode voltage - Cathode voltage (Diode "OFF")	-5		0.8	V
T_J	Junction temperature	-40		150	°C
T_A	Ambient temperature	-40		125	°C
$ V_{IO} $	Input-to-output operating voltage			1500	V_{DC}

6.4 Thermal Information

THERMAL METRIC ⁽¹⁾		UCC23113	UNIT
		DWY (SOIC-6)	
		6 PINS	
R_{qJA}	Junction-to-ambient thermal resistance	138	°C/W
$R_{qJC(top)}$	Junction-to-case (top) thermal resistance	79.2	°C/W
R_{qJB}	Junction-to-board thermal resistance	76.4	°C/W
Y_{JT}	Junction-to-top characterization parameter	44.9	°C/W

6.4 Thermal Information (continued)

THERMAL METRIC ⁽¹⁾		UCC23113	UNIT
		DWY (SOIC-6)	
		6 PINS	
Y _{JB}	Junction-to-board characterization parameter	72.8	°C/W

- (1) For more information about traditional and new thermal metrics, see the [Semiconductor and IC Package Thermal Metrics](#) application report.

6.5 Power Ratings

PARAMETER		TEST CONDITIONS	MIN	TYP	MAX	UNIT
P _D	Maximum power dissipation on input and output ⁽¹⁾	V _{DD} - V _{EE} = 20 V, I _F = 10mA, 10-kHz, 50% duty cycle, square wave, 180-nF load, T _A = 25°C			750	mW
P _{D1}	Maximum input power dissipation ⁽²⁾				10	mW
P _{D2}	Maximum output power dissipation				740	mW

- (1) Derate at 6 mW/°C beyond 25°C ambient temperature
 (2) Recommended maximum P_{D1} = 40mW. Absolute maximum P_{D1} = 55mW

6.6 Insulation Specifications

PARAMETER		TEST CONDITIONS	SPECIFICATION	UNIT
CLR	External clearance ⁽¹⁾	Shortest terminal-to-terminal distance through air	>8.5	mm
CPG	External Creepage ⁽¹⁾	Shortest terminal-to-terminal distance across the package surface	>8.5	mm
DTI	Distance through the insulation	Minimum internal gap (internal clearance)	>17	μm
CTI	Comparative tracking index	DIN EN 60112 (VDE 0303-11); IEC 60112	>600	V
	Material Group	According to IEC 60664-1	I	
C _{IO}	Barrier capacitance, input to output ⁽²⁾		0.5	pF
R _{IO}	Insulation resistance, input to output ⁽²⁾		>10 ⁹	Ω

- (1) Creepage and clearance requirements should be applied according to the specific equipment isolation standards of an application. Care should be taken to maintain the creepage and clearance distance of a board design to ensure that the mounting pads of the isolator on the printed-circuit board do not reduce this distance. Creepage and clearance on a printed-circuit board become equal in certain cases. Techniques such as inserting grooves, ribs, or both on a printed-circuit board are used to help increase these specifications.
- (2) All pins on each side of the barrier tied together creating a two-pin device.

6.7 Electrical Characteristics

Over recommended operating conditions unless otherwise noted. All typical values are at $T_A = 25^\circ\text{C}$, $V_{DD}-V_{EE} = 15\text{V}$.

PARAMETER		TEST CONDITIONS	MIN	TYP	MAX	UNIT
INPUT						
I_{FLH}	Input Forward Threshold Current Low to High	$V_{DD} - V_{EE} = 15\text{V}$	1.5	2.8	4	mA
V_F	Input Forward Voltage	$I_F = 10\text{ mA}$	1.8	2.1	2.4	V
$\Delta V_F/\Delta T$	Temp Coefficient of Input Forward Voltage	$I_F = 10\text{ mA}$		1	1.35	mV/°C
V_R	Input Reverse Breakdown Voltage	$I_R = 10\text{ }\mu\text{A}$	6			V
C_{IN}	Input Capacitance	$F = 0.5\text{ MHz}$		15		pF
OUTPUT						
I_{OH}	Output Peak Source Current	$I_F = 10\text{ mA}$, $V_{DD} = 15\text{V}$, $C_{LOAD} = 0.18\text{ }\mu\text{F}$, $C_{VDD} = 10\text{ }\mu\text{F}$, pulse width $< 10\text{ }\mu\text{s}$		5		A
I_{OL}	Output Peak Sink Current	$V_F = 0\text{ V}$, $V_{DD} = 15\text{V}$, $C_{LOAD} = 0.18\text{ }\mu\text{F}$, $C_{VDD} = 10\text{ }\mu\text{F}$, pulse width $< 10\text{ }\mu\text{s}$		5		A
V_{OH}	High Level Output Voltage	$I_F = 10\text{ mA}$, $I_O = -20\text{ mA}$	VDD-0.07	VDD-0.18	VDD-0.36	V
		$I_F = 10\text{ mA}$, $I_O = 0\text{ mA}$	VDD			V
V_{OL}	Low Level Output Voltage	$V_F = 0\text{ V}$, $I_O = 20\text{ mA}$			25	mV
I_{DD_H}	Output Supply Current (Diode On)	$I_F = 10\text{ mA}$, $I_O = 0\text{ mA}$			2.2	mA
I_{DD_L}	Output Supply Current (Diode Off)	$V_F = 0\text{ V}$, $I_O = 0\text{ mA}$			2	mA
UNDER VOLTAGE LOCKOUT						
$UVLO_R$	Under Voltage Lockout V_{DD} rising (12V UVLO)	$I_F = 10\text{ mA}$	11	12.5	13.5	V
$UVLO_F$	Under Voltage Lockout V_{DD} falling (12V UVLO)	$I_F = 10\text{ mA}$	10	11.5	12.5	V
$UVLO_{HYS}$	UVLO Hysteresis (12V UVLO)	$I_F = 10\text{ mA}$		1.0		V

6.8 Switching Characteristics

Over recommended operating conditions unless otherwise noted. All typical values are at $T_A = 25^\circ\text{C}$, $V_{DD}-V_{EE} = 15\text{V}$.

PARAMETER		TEST CONDITIONS	MIN	TYP	MAX	UNIT
t_r	Output-signal Rise Time	$C_g = 1\text{ nF}$ $F_{SW} = 20\text{ kHz}$, (50% Duty Cycle) $V_{DD} = 15\text{V}$			28	ns
t_f	Output-signal Fall Time				25	ns
t_{PLH}	Propagation Delay, Low to High			70	105	ns
t_{PHL}	Propagation Delay, High to Low			70	105	ns
t_{PWD}	Pulse Width Distortion $ t_{PHL} - t_{PLH} $				35	ns
$t_{sk(pp)}$	Part-to-Part Skew in Propagation Delay Between any Two Parts ⁽¹⁾	$C_g = \text{open}$ $F_{SW} = 20\text{ kHz}$, (50% Duty Cycle) $V_{DD} = 15\text{V}$, $I_F = 10\text{ mA}$			25	ns
t_{UVLO_rec}	UVLO Recovery Delay	V_{DD} rising from 0V to 15V		20	30	μs
CMT_H	Common-mode Transient Immunity (Output High)	$I_F = 10\text{ mA}$, $V_{CM} = 1500\text{ V}$, $V_{DD} = 30\text{V}$, $T_A = 25^\circ\text{C}$	100			V/ns
CMT_L	Common-mode Transient Immunity (Output Low)	$V_F = 0\text{ V}$, $V_{CM} = 1500\text{ V}$, $V_{DD} = 30\text{V}$, $T_A = 25^\circ\text{C}$	100			V/ns

(1) $t_{sk(pp)}$ is the magnitude of the difference in propagation delay times between the output of different devices switching in the same direction while operating at identical supply voltages, temperature, input signals and loads ensured by characterization.

6.9 Typical Characteristics

$V_{DD} = 15\text{ V}$, $1\text{-}\mu\text{F}$ capacitor from V_{DD} to V_{EE} , $C_{LOAD} = 1\text{ nF}$ for timing tests and 180 nF for I_{OH} and I_{OL} tests, $T_J = -40^\circ\text{C}$ to $+150^\circ\text{C}$, (unless otherwise noted)

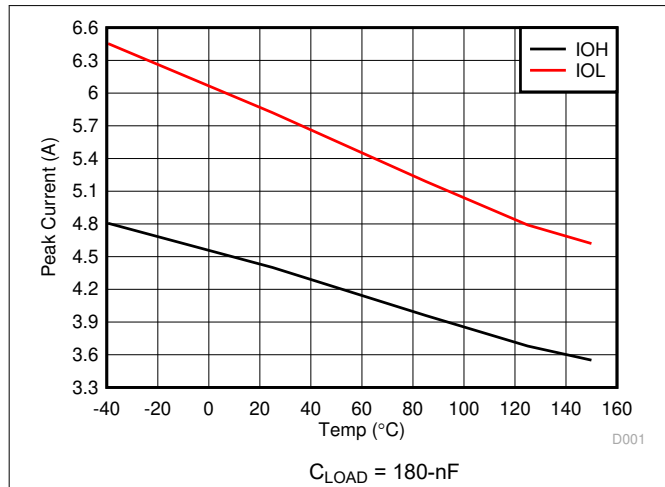

Figure 6-1. Output Drive Currents vs Temperature

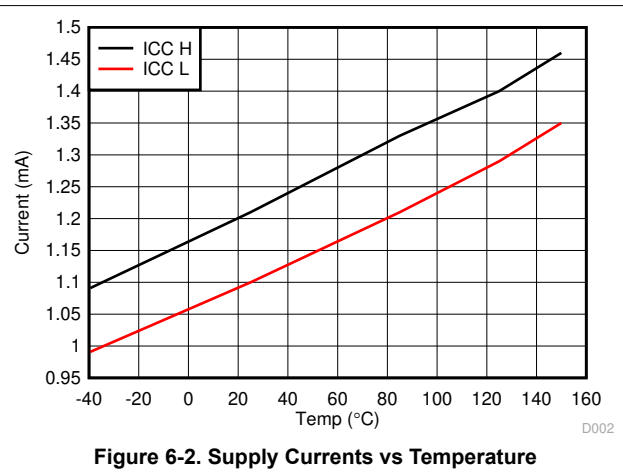

Figure 6-2. Supply Currents vs Temperature

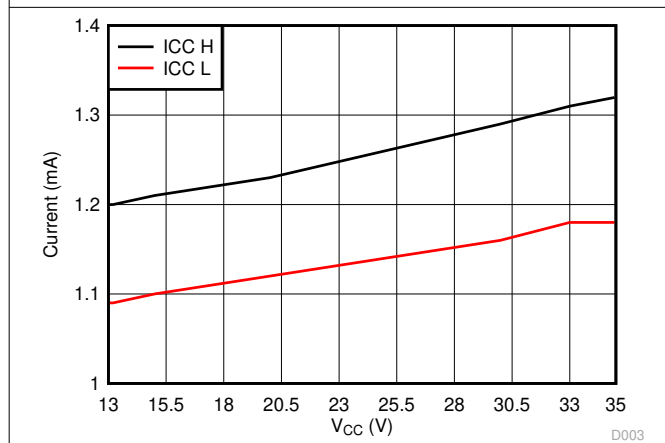

Figure 6-3. Supply Current vs Supply Voltage

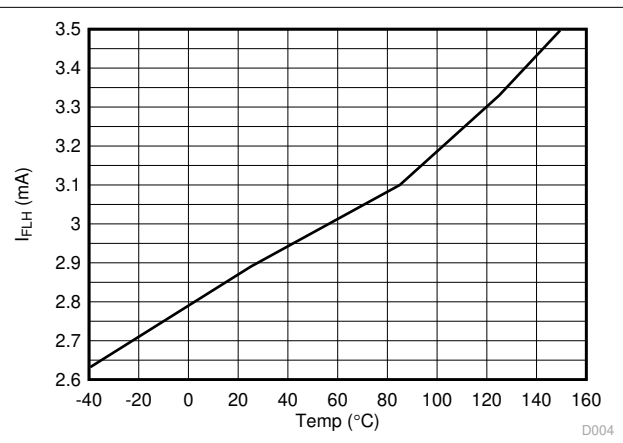

Figure 6-4. Forward Threshold Current vs Temperature

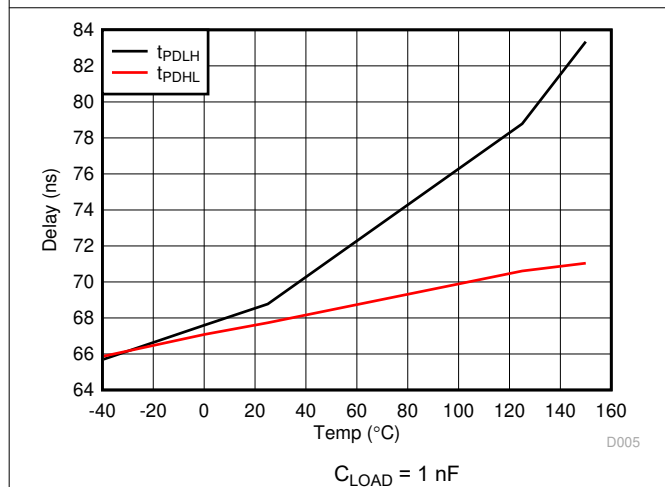

Figure 6-5. Propagation Delay vs Temperature

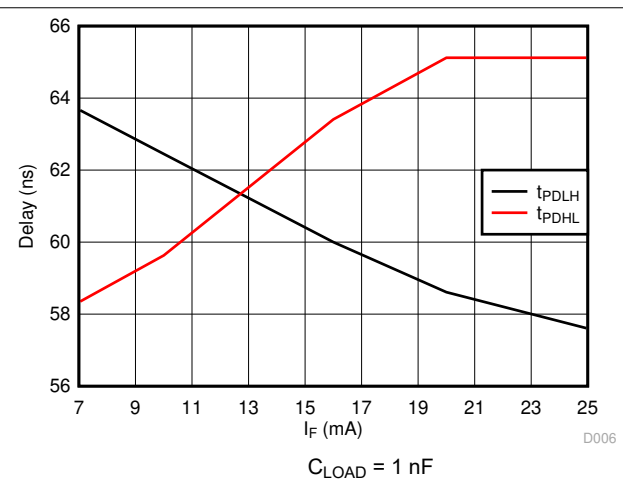

Figure 6-6. Propagation Delay vs Forward Current

6.9 Typical Characteristics (continued)

$V_{DD} = 15\text{ V}$, $1\text{-}\mu\text{F}$ capacitor from V_{DD} to V_{EE} , $C_{LOAD} = 1\text{ nF}$ for timing tests and 180 nF for I_{OH} and I_{OL} tests, $T_J = -40^\circ\text{C}$ to $+150^\circ\text{C}$, (unless otherwise noted)

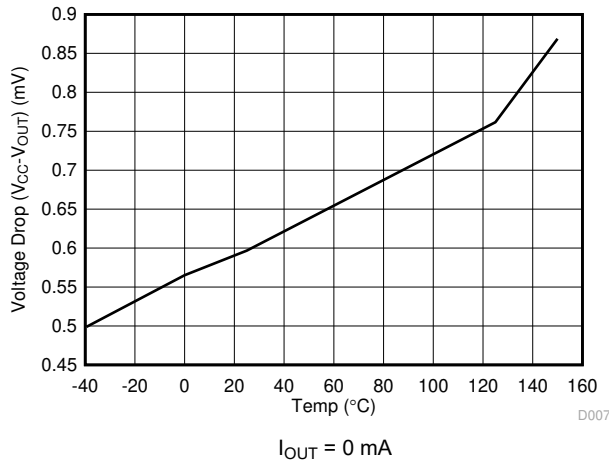

Figure 6-7. V_{OH} (No Load) vs Temperature

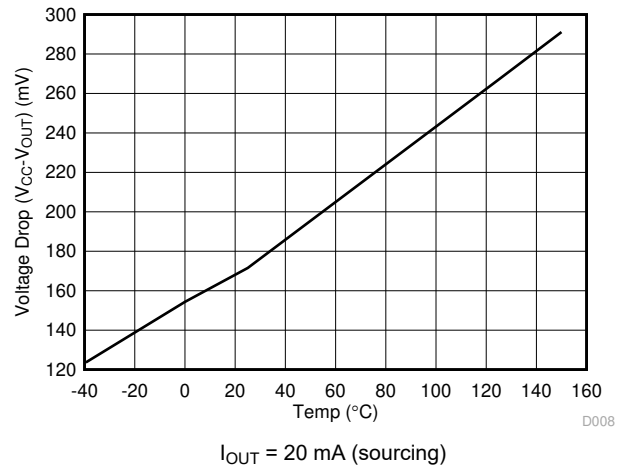

Figure 6-8. V_{OH} (20mA Load) vs Temperature

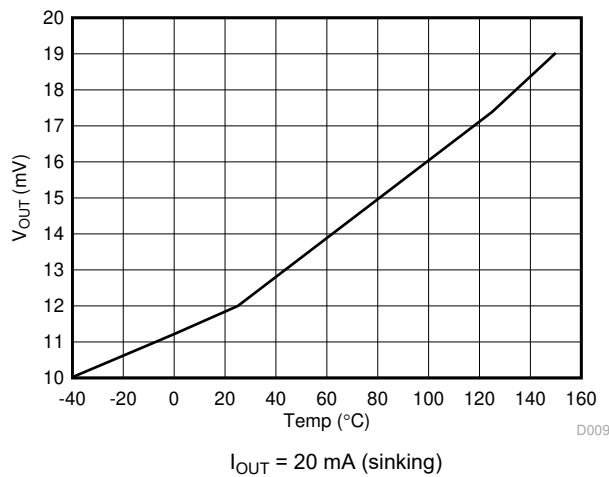

Figure 6-9. V_{OL} vs Temperature

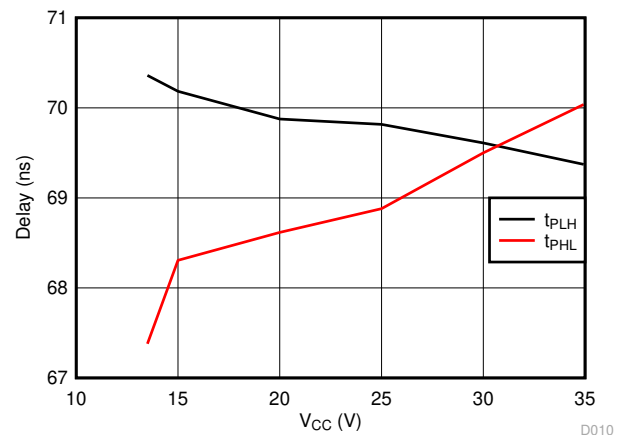

Figure 6-10. Propagation Delay vs Supply Voltage

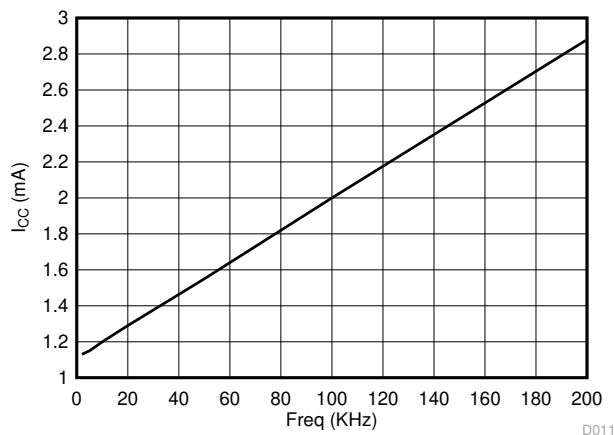

Figure 6-11. Supply Current vs Frequency

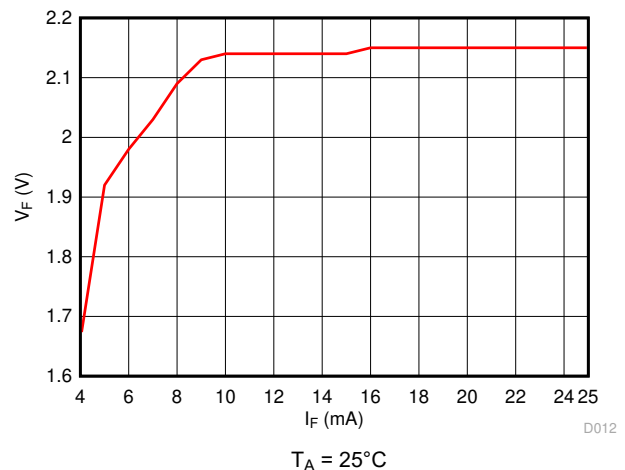

Figure 6-12. Forward Current vs Forward Voltage Drop

6.9 Typical Characteristics (continued)

$V_{DD} = 15\text{ V}$, $1\text{-}\mu\text{F}$ capacitor from V_{DD} to V_{EE} , $C_{LOAD} = 1\text{ nF}$ for timing tests and 180 nF for I_{OH} and I_{OL} tests, $T_J = -40^\circ\text{C}$ to $+150^\circ\text{C}$, (unless otherwise noted)

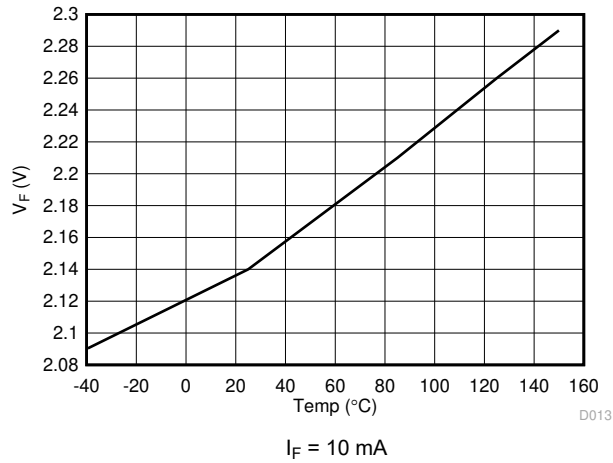

Figure 6-13. Forward Voltage Drop vs Temperature

7 Parameter Measurement Information

7.1 Propagation Delay, Rise Time and Fall Time

Figure 7-1 shows the propagation delay from the input forward current I_F , to V_{OUT} . This figure also shows the circuit used to measure the rise (t_r) and fall (t_f) times and the propagation delays $t_{PD,LH}$ and $t_{PD,HL}$.

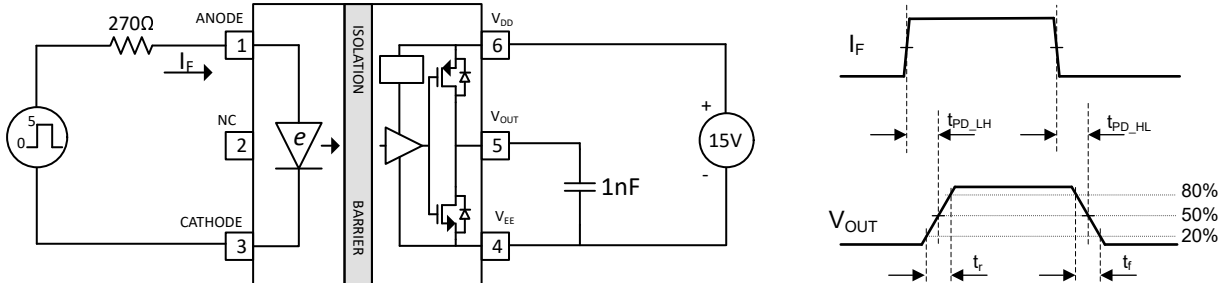

Figure 7-1. I_F to V_{OUT} Propagation Delay, Rise Time and Fall Time

7.2 I_{OH} and I_{OL} testing

Figure 7-2 shows the circuit used to measure the output drive currents I_{OH} and I_{OL} . A load capacitance of 180nF is used at the output. The peak dv/dt of the capacitor voltage is measured in order to determine the peak source and sink currents of the gate driver.

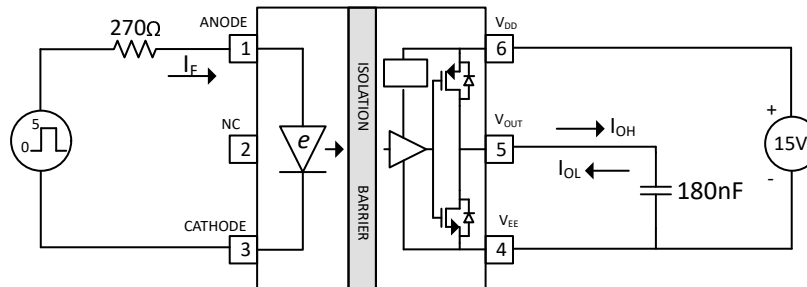

Figure 7-2. I_{OH} and I_{OL}

7.3 CMTI Testing

Figure 7-3 is the simplified diagram of the CMTI testing. Common mode voltage is set to 1500V. The test is performed with $I_F = 10\text{mA}$ ($V_{OUT} = \text{High}$) and $I_F = 0\text{mA}$ ($V_{OUT} = \text{LOW}$). The diagram also shows the fail criteria for both cases. During the application on the CMTI pulse with $I_F = 10\text{mA}$, if V_{OUT} drops from V_{DD} to $\frac{1}{2}V_{DD}$ it is considered as a failure. With $I_F = 0\text{mA}$, if V_{OUT} rises above 1V, it is considered as a failure.

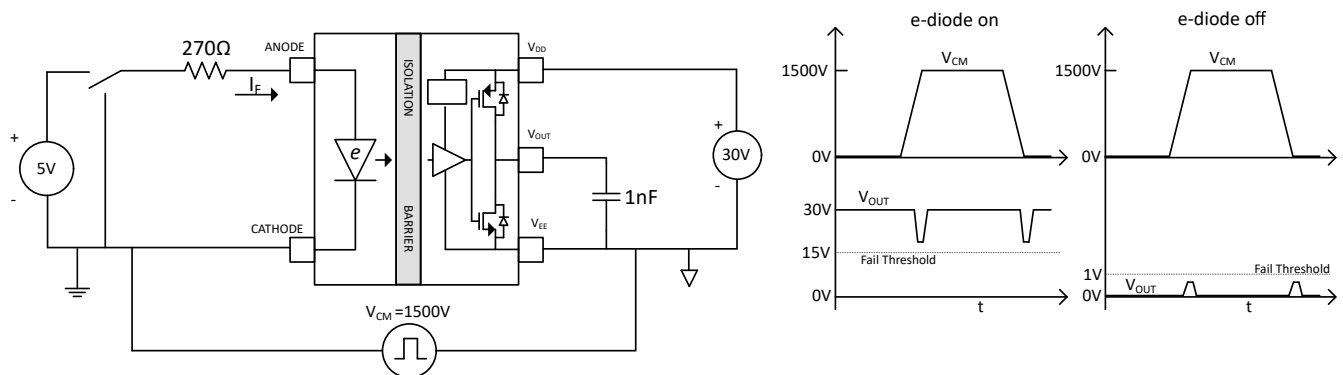

Figure 7-3. CMTI Test Circuit for UCC23113

8 Detailed Description

8.1 Overview

The UCC23113 is a single channel isolated gate driver, with an opto-compatible input stage, that can drive IGBTs, MOSFETs and SiC FETs. It has 5-A peak output current capability with max output driver supply voltage of 30 V. The inputs and the outputs are galvanically isolated. UCC23113 is offered in an industry standard 6 pin (SO6) package with >8.5 mm creepage and clearance. It has a working voltage of 1.5-kV_{DC}. It is pin-to-pin compatible with standard opto isolated gate drivers. While standard opto isolated gate drivers use an LED as the input stage, UCC23113 uses an emulated diode (or "e-diode") as the input stage which does not use light emission to transmit signals across the isolation barrier. The input stage is isolated from the driver stage by dual, series HV SiO₂ capacitors in full differential configuration that offers best-in-class common mode transient immunity of > 100 kV/us. The e-diode input stage along with the isolation technology gives UCC23113 several performance advantages over standard opto isolated gate drivers. They are as follows:

1. Since the e-diode does not use light emission for its operation, the reliability and aging characteristics of UCC23113 are naturally superior to those of standard opto isolated gate drivers.
2. Higher ambient operating temperature range of 125°C, compared to only 105°C for most opto isolated gate drivers
3. The e-diode forward voltage drop has less part-to-part variation and smaller variation across temperature. Hence, the operating point of the input stage is more stable and predictable across different parts and operating temperature.
4. Higher common mode transient immunity than opto isolated gate drivers
5. Smaller propagation delay than opto isolated gate drivers
6. Due to superior process controls achievable in UCC23113 isolation compared to opto isolation, there is less part-to-part skew in the prop delay, making the system design simpler and more robust
7. Smaller pulse width distortion than opto isolated gate drivers

The signal across the isolation has an on-off keying (OOK) modulation scheme to transmit the digital data across a silicon dioxide based isolation barrier (see [Figure 8-1](#)). The transmitter sends a high-frequency carrier across the barrier to represent one digital state and sends no signal to represent the other digital state. The receiver demodulates the signal after advanced signal conditioning and produces the output through a buffer stage. The UCC23113 also incorporates advanced circuit techniques to maximize the CMTI performance and minimize the radiated emissions from the high frequency carrier and IO buffer switching. [Figure 8-2](#) shows conceptual detail of how the OOK scheme works.

8.2 Functional Block Diagram

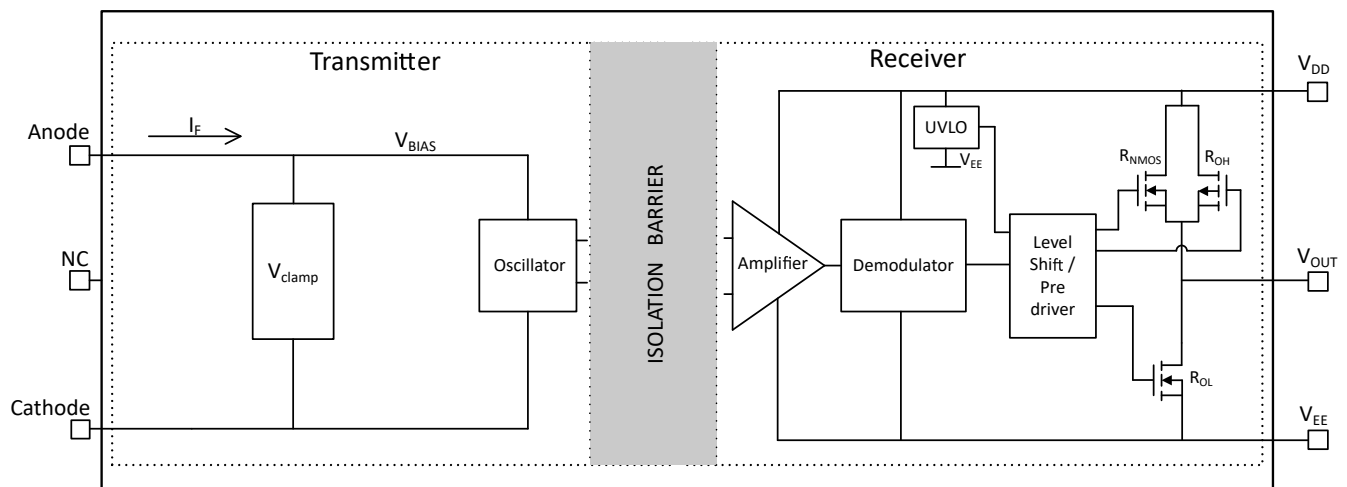

Figure 8-1. Conceptual Block Diagram of a Isolated Gate Driver with an Opto Emulated Input Stage (SOIC-6 package)

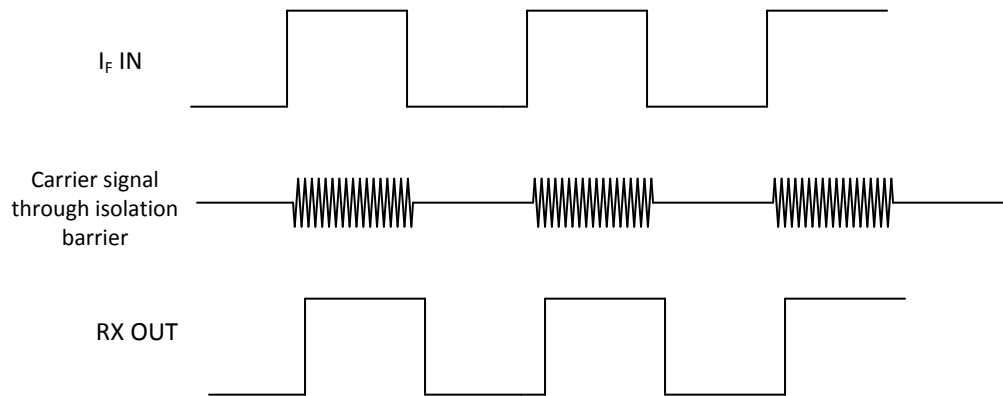

Figure 8-2. On-Off Keying (OOK) Based Modulation Scheme

8.3 Feature Description

8.3.1 Power Supply

Since the input stage is an emulated diode, no power supply is needed at the input.

The output supply, V_{DD} , supports a voltage range from 13 V to 30 V. For operation with bipolar supplies, the power device is turned off with a negative voltage on the gate with respect to the emitter or source. This configuration prevents the power device from unintentionally turning on because of current induced from the Miller effect. The typical values of the V_{DD} and V_{EE} output supplies for bipolar operation are 15 V and -8 V with respect to GND for IGBTs, and 20 V and -5 V for SiC MOSFETs.

For operation with unipolar supply, the V_{DD} supply is connected to 15 V with respect to GND for IGBTs, and 20 V for SiC MOSFETs. The V_{EE} supply is connected to 0 V.

8.3.2 Input Stage

The input stage of UCC23113 is simply the e-diode and therefore has an Anode (Pin 1) and a Cathode (Pin 3). Pin 2 has no internal connection and can be left open or connected to ground. The input stage does not have a power and ground pin. When the e-diode is forward biased by applying a positive voltage to the Anode with respect to the Cathode, a forward current I_F flows into the e-diode. The forward voltage drop across the e-diode is 2.1 V (typ). An external resistor should be used to limit the forward current. The recommended range for the forward current is 7 mA to 16 mA. When I_F exceeds the threshold current I_{FLH} (2.8 mA typ) a high frequency signal is transmitted across the isolation barrier through the high voltage SiO₂ capacitors. The HF signal is detected by the receiver and V_{OUT} is driven high. See [Section 9.2.2.1](#) for information on selecting the input resistor. The dynamic impedance of the e-diode is very small (<1.0 Ω) and the temperature coefficient of the e-diode forward voltage drop is <1.35 mV/°C. This leads to excellent stability of the forward current I_F across all operating conditions. If the Anode voltage drops below V_{F_HL} (0.8 V), or reverse biased, the gate driver output is driven low. The reverse breakdown voltage of the e-diode is >6 V. So for normal operation, a reverse bias of up to 5 V is allowed. The large reverse breakdown voltage of the e-diode enables UCC23113 to be operated in interlock architecture (see example in [Figure 8-3](#)) where V_{SUP} can be as high as 5 V. The system designer has the flexibility to choose a 3.3 V or 5.0 V PWM signal source to drive the input stage of UCC23113 using an appropriate input resistor. The example shows two gate drivers driving a set of IGBTs. The inputs of the gate drivers are connected as shown and driven by two buffers that are controlled by the MCU. Interlock architecture prevents both the e-diodes from being "ON" at the same time, preventing shoot through in the IGBTs. It also ensures that if both PWM signals are erroneously stuck high (or low) simultaneously, both gate driver outputs are driven low.

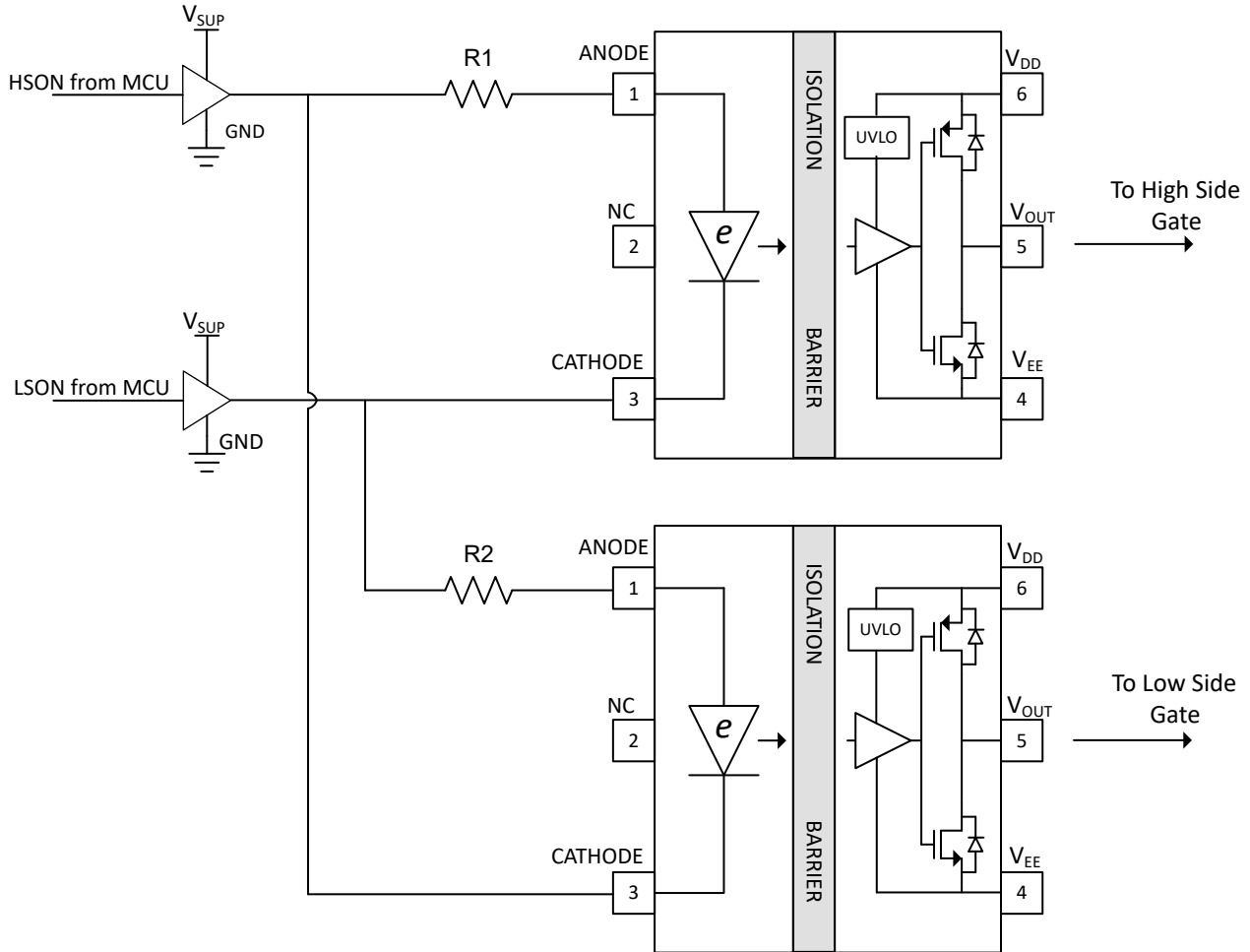

Figure 8-3. Interlock

8.3.3 Output Stage

The output stages of the UCC23113 family feature a pullup structure that delivers the highest peak-source current when it is most needed which is during the Miller plateau region of the power-switch turnon transition (when the power-switch drain or collector voltage experiences dV/dt). The output stage pullup structure features a P-channel MOSFET and an additional pull-up N-channel MOSFET in parallel. The function of the N-channel MOSFET is to provide a brief boost in the peak-sourcing current, enabling fast turnon. Fast turnon is accomplished by briefly turning on the N-channel MOSFET during a narrow instant when the output is changing states from low to high. The on-resistance of this N-channel MOSFET (R_{NMOS}) is approximately 5.1Ω when activated.

Table 8-1. UCC23113 On-Resistance

R_{NMOS}	R_{OH}	R_{OL}	UNIT
5.1	9.5	0.40	Ω

The R_{OH} parameter is a DC measurement and is representative of the on-resistance of the P-channel device only. This parameter is only for the P-channel device because the pullup N-channel device is held in the OFF state in DC condition and is turned on only for a brief instant when the output is changing states from low to high. Therefore, the effective resistance of the UCC23113 pullup stage during this brief turnon phase is much lower than what is represented by the R_{OH} parameter, yielding a faster turn on. The turnon-phase output resistance is the parallel combination $R_{OH} \parallel R_{NMOS}$.

The pull-down structure in the UCC23113 is simply composed of an N-channel MOSFET. The output voltage swing between V_{DD} and V_{EE} provides rail-to-rail operation because of the MOS-out stage which delivers very low dropout.

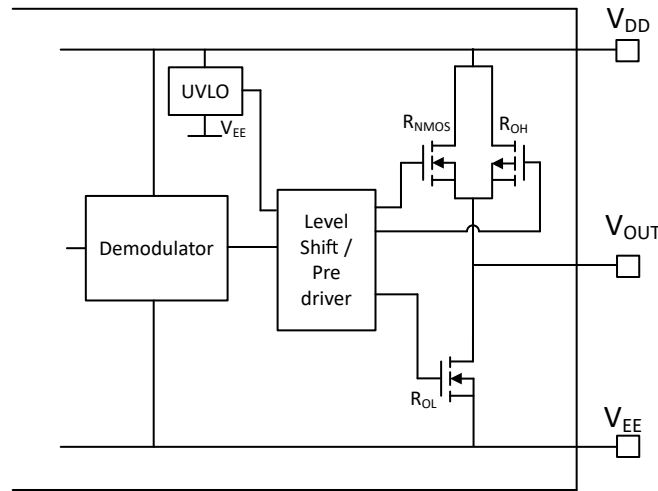

Figure 8-4. Output Stage

8.3.4 Protection Features

8.3.4.1 Undervoltage Lockout (UVLO)

UVLO function is implemented for V_{DD} and V_{EE} pins to prevent an under-driven condition on IGBTs and MOSFETs. When V_{DD} is lower than $UVLO_R$ at device start-up or lower than $UVLO_F$ after start-up, the voltage-supply UVLO feature holds the effected output low, regardless of the input forward current as shown in [Table 8-2](#). The V_{DD} UVLO protection has a hysteresis feature ($UVLO_{hys}$). This hysteresis prevents chatter when the power supply produces ground noise which allows the device to permit small drops in bias voltage, which occurs when the device starts switching and operating current consumption increases suddenly.

When V_{DD} drops below $UVLO_F$, a delay, t_{UVLO_rec} occurs on the output when the supply voltage rises above $UVLO_R$ again.

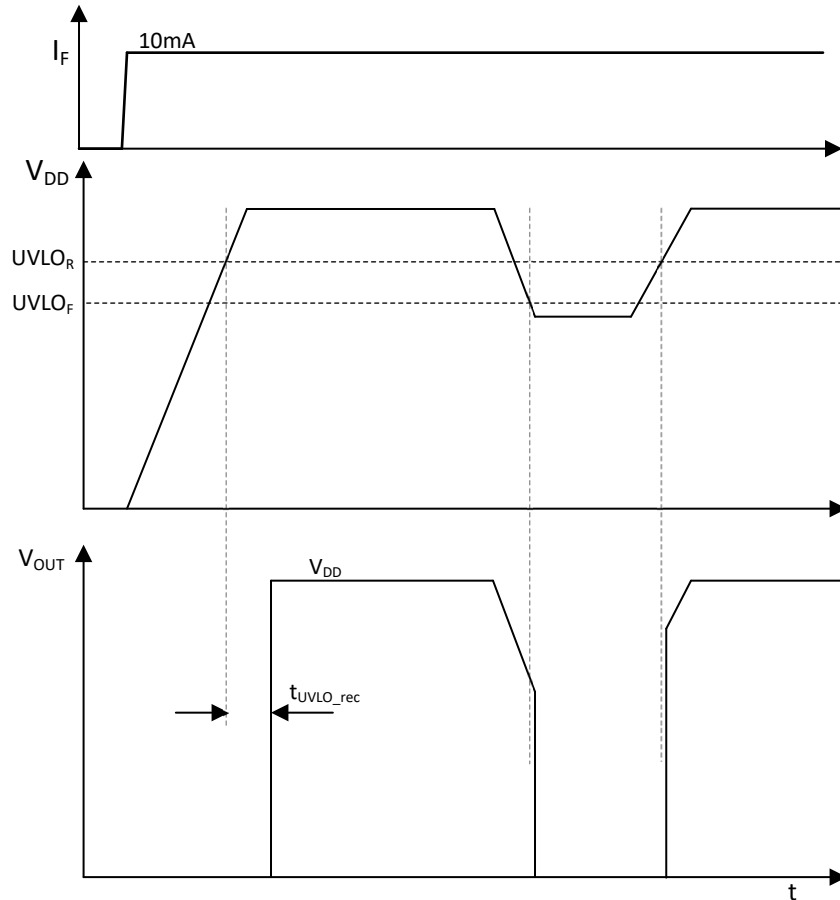

Figure 8-5. UVLO Functionality

8.3.4.2 Active Pulldown

The active pull-down function is used to pull the IGBT or MOSFET gate to the low state when no power is connected to the V_{DD} supply. This feature prevents false IGBT and MOSFET turn-on by clamping V_{OUT} pin to approximately 2 V.

When the output stage of the driver is in an unbiased condition (V_{DD} floating), the driver outputs (see [Figure 8-4](#)) are held low by an active clamp circuit that limits the voltage rise on the driver outputs. In this condition, the upper PMOS and NMOS are held off while the lower NMOS gate is tied to the driver output through an internal 500-k Ω resistor. In this configuration, the lower NMOS device effectively clamps the output (V_{OUT}) to less than 2 V.

8.3.4.3 Short-Circuit Clamping

The short-circuit clamping function is used to clamp voltages at the driver output and pull the output pin V_{OUT} slightly higher than the V_{DD} voltage during short-circuit conditions. The short-circuit clamping function helps protect the IGBT or MOSFET gate from overvoltage breakdown or degradation. The short-circuit clamping function is implemented by adding a diode connection between the dedicated pins and the V_{DD} pin inside the driver. The internal diodes can conduct up to 500-mA current for a duration of 10 μ s and a continuous current of 20 mA. Use external Schottky diodes to improve current conduction capability as needed.

8.4 Device Functional Modes

Table 8-2 and Table 8-3 list the functional modes for UCC23113.

Table 8-2. Function Table for UCC23113 with V_{DD} Rising

e-diode	V_{DD}	V_{OUT}
OFF ($I_F < I_{FLH}$)	0 V - 30 V	Low
ON ($I_F > I_{FLH}$)	0 V - $UVLO_R$	Low
ON ($I_F > I_{FLH}$)	$UVLO_R$ - 30 V	High

Table 8-3. Function Table for UCC23113 with V_{DD} Falling

e-diode	V_{DD}	V_{OUT}
OFF ($I_F < I_{FLH}$)	0 V - 30 V	Low
ON ($I_F > I_{FLH}$)	$UVLO_F$ - 0 V	Low
ON ($I_F > I_{FLH}$)	30 V - $UVLO_F$	High

8.4.1 ESD Structure

Figure 8-6 shows the multiple diodes involved in the ESD protection components of the UCC23113 device. This provides pictorial representation of the absolute maximum rating for the device.

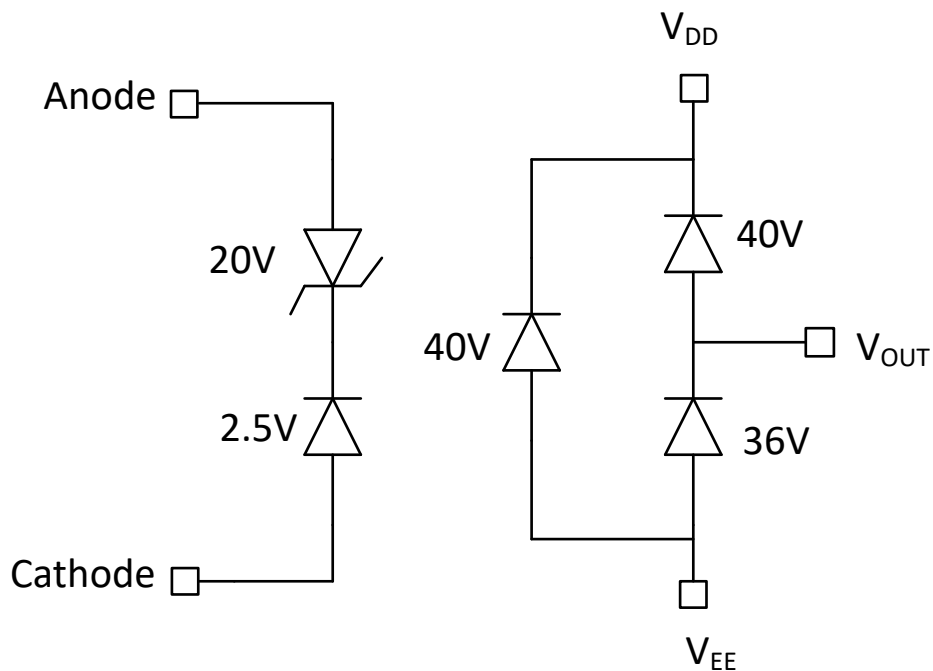

Figure 8-6. ESD Structure

9 Application and Implementation

Note

Information in the following applications sections is not part of the TI component specification, and TI does not warrant its accuracy or completeness. TI's customers are responsible for determining suitability of components for their purposes, as well as validating and testing their design implementation to confirm system functionality.

9.1 Application Information

The UCC23113 is a single channel, isolated gate driver with opto-compatible input for power semiconductor devices, such as MOSFETs, IGBTs, or SiC MOSFETs. It is intended for use in applications such as motor control, industrial inverters, and switched-mode power supplies. It differs from standard opto isolated gate drivers as it does not have an LED input stage. Instead of an LED, it has an emulated diode (e-diode). To turn the e-diode "ON", a forward current in the range of 7 mA to 16 mA should be driven into the Anode. This will drive the gate driver output High and turn on the power FET. Typically, MCUs are not capable of providing the required forward current. Hence a buffer has to be used between the MCU and the input stage of UCC23113. Typical buffer power supplies are either 5 V or 3.3 V. A resistor is needed between the buffer and the input stage of the UCC23113 to limit the current. It is simple, but important to choose the right value of resistance. The resistor tolerance, buffer supply voltage tolerance and output impedance of the buffer, have to be considered in the resistor selection. This will ensure that the e-diode forward current stays within the recommended range of 7 mA to 16 mA. Detailed design recommendations are given in the [Section 9.1](#). The current driven input stage offers excellent noise immunity that is need in high power motor drive systems, especially in cases where the MCU cannot be located close to the isolated gate driver. UCC23113 offers best in class CMTI performance of >100 kV/ μ s at 1500 V common-mode voltages.

The e-diode is capable of 25 mA continuous in the forward direction. The forward voltage drop of the e-diode has a very tight part to part variation (1.8 V min to 2.4 V max). The temperature coefficient of the forward drop is <1.35 mV/ $^{\circ}$ C. The dynamic impedance of the e-diode in the forward biased region is \sim 1 Ω . All of these factors contribute in excellent stability of the e-diode forward current. To turn the e-diode "OFF", the Anode - Cathode voltage should be <0.8 V, or I_F should be < I_{FLH} . The e-diode can also be reverse biased up to 5 V (6 V abs max) in order to turn it off and bring the gate driver output low. The large reverse breakdown voltage of the input stage provides system designers with the feature to use interlocking circuit and gain protection against shoot-through when driving a half-bridge power stage.

The output power supply for UCC23113 can be as high as 30 V (36 V abs max). The output power supply can be configured externally as a single isolated supply up to 30 V or isolated bipolar supply such that $V_{DD}-V_{EE}$ does not exceed 30 V, or it can be bootstrapped (with external diode and capacitor) if the system uses a single power supply with respect to the power ground. Typical quiescent power supply current from V_{DD} is 1.2 mA (max 2.2 mA).

9.2 Typical Application

The circuit in [Figure 9-1](#), shows a typical application for driving IGBTs.

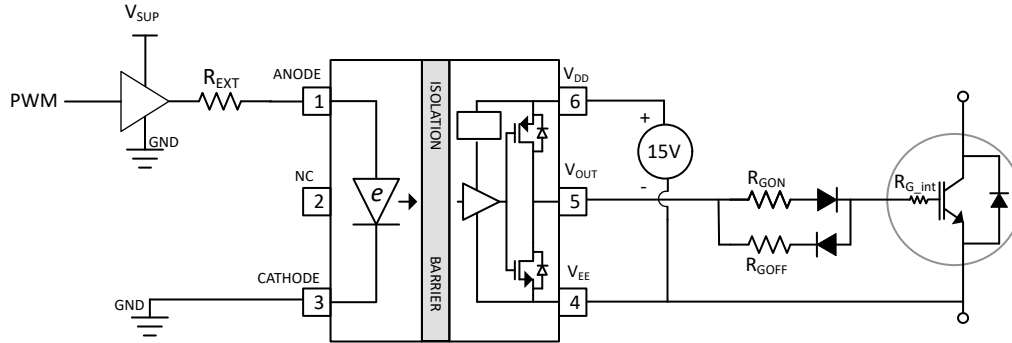

Figure 9-1. Typical Application Circuit for UCC23113 to Drive IGBT

9.2.1 Design Requirements

[Table 9-1](#) lists the recommended conditions to observe the input and output of the UCC23113 gate driver.

Table 9-1. UCC23113 Design Requirements

PARAMETER	VALUE	UNIT
V_{DD}	15	V
I_F	10	mA
Switching frequency	8	kHz

9.2.2 Detailed Design Procedure

9.2.2.1 Selecting the Input Resistor

The input resistor limits the current that flows into the e-diode when it is forward biased. The threshold current I_{FLH} is 2.8 mA typ. The recommended operating range for the forward current is 7 mA to 16 mA (e-diode ON). All the electrical specifications are ensured in this range. The resistor should be selected such that for typical operating conditions, I_F is 10 mA. Following are the list of factors that will affect the exact value of this current:

1. Supply Voltage V_{SUP} variation
2. Manufacturer's tolerance for the resistor and variation due to temperature
3. e-diode forward voltage drop variation (at $I_F=10$ mA, $V_F=$ typ 2.1 V, min 1.8 V, max 2.4 V, with a temperature coefficient < 1.35 mV/°C and dynamic impedance < 1 Ω)

See [Figure 9-2](#) for the schematic using using a single buffer and anode resistor combination to drive the input stage of UCC23113. The input resistor can be selected using [Equation 1](#).

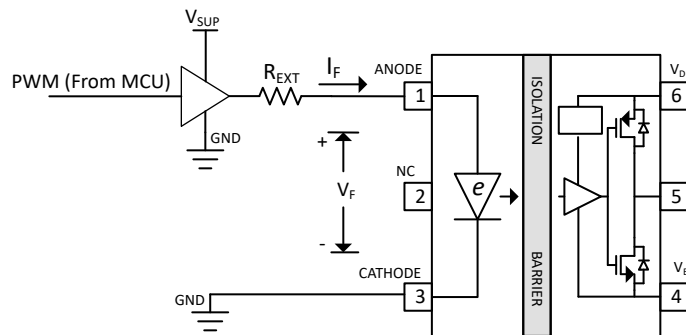

Figure 9-2. Driving the Input Stage of UCC23113 with One Buffer and Anode Resistor

$$R_{EXT} = \frac{V_{SUP} - V_F}{I_F} - R_{OH_buf} \quad (1)$$

[Table 9-2](#) shows the range of values for R_{EXT} for [Figure 9-2](#). The assumptions used in deriving the range for R_{EXT} are as follows:

1. Target forward current I_F is 7 mA min, 10 mA typ and 16 mA max
2. e-diode forward voltage drop is 1.8 V to 2.
3. V_{SUP} (Buffer supply voltage) is 5 V with $\pm 5\%$ tolerance
4. Manufacturer's tolerance for R_{EXT} is 1%
5. R_{OH} (buffer output impedance in output "High" state) is 13 Ω min, 18 Ω typ and 22 Ω max

Table 9-2. R_{EXT} Values to Drive the Input Stage

Configuration	R_{EXT} Ω		
	Min	Typ	Max
Single Buffer and R_{EXT}	204	272	311

9.2.2.2 Gate Driver Output Resistor

The external gate-driver resistors, $R_{G(ON)}$ and $R_{G(OFF)}$ are used to:

1. Limit ringing caused by parasitic inductances and capacitances
2. Limit ringing caused by high voltage or high current switching dv/dt , di/dt , and body-diode reverse recovery
3. Fine-tune gate drive strength, specifically peak sink and source current to optimize the switching loss
4. Reduce electromagnetic interference (EMI)

The output stage has a pull up structure consisting of a P-channel MOSFET and an N-channel MOSFET in parallel. The combined peak source current is 5 A. Use [Equation 2](#) to estimate the peak source current as an example.

$$I_{OH} = \min \left[5A, \frac{V_{DD} - V_{GDF}}{R_{NMOS} \parallel [R_{OH} + R_{GON} + R_{GFET_INT}]} \right] \quad (2)$$

where

- R_{GON} is the external turnon resistance.
- R_{GFET_Int} is the power transistor internal gate resistance, found in the power transistor data sheet. Assume 0 Ω for this example.
- I_{OH} is the peak source current which is the minimum value between 5 A, the gate-driver peak source current, and the calculated value based on the gate-drive loop resistance.
- V_{GDF} is the forward voltage drop for each of the diodes in series with R_{GON} and R_{GOFF} . The diode drop for this example is 0.7 V.

In this example, the peak source current is approximately 1.7 A as calculated in [Equation 3](#).

$$I_{OH} = \min \left[5A, \frac{15 - 0.7}{5.1\Omega \parallel [9.5\Omega + 5\Omega + 0\Omega]} \right] = 1.72A \quad (3)$$

Similarly, use [Equation 4](#) to calculate the peak sink current.

$$I_{OL} = \min \left[5A, \frac{V_{DD} - V_{GDF}}{R_{OL} + R_{GOFF} + R_{GFET_INT}} \right] \quad (4)$$

where

- R_{GOFF} is the external turnoff resistance.
- I_{OL} is the peak sink current which is the minimum value between 5 A, the gate-driver peak sink current, and the calculated value based on the gate-drive loop resistance.

In this example, the peak sink current is the minimum of 5 A and [Equation 5](#).

$$I_{OL} = \min \left[5A, \frac{15 - 0.7}{0.4\Omega + 10\Omega + 0\Omega} \right] = 1.38A \quad (5)$$

The diodes shown in series with each, R_{GON} and R_{GOFF} , in [Figure 9-1](#) ensure the gate drive current flows through the intended path, respectively, during turn-on and turn-off. Note that the diode forward drop reduces the voltage level at the gate of the power switch. To achieve rail-to-rail gate voltage levels, add a resistor from the V_{OUT} pin to the power switch gate, with a resistance value approximately 20 times higher than R_{GON} and R_{GOFF} . For the examples described in this section, a good choice is 100 Ω to 200 Ω .

Note

The estimated peak current is also influenced by PCB layout and load capacitance. Parasitic inductance in the gate-driver loop can slow down the peak gate-drive current and introduce overshoot and undershoot. Therefore, TI strongly recommends that the gate-driver loop should be minimized. Conversely, the peak source and sink current is dominated by loop parasitics when the load capacitance (C_{ISS}) of the power transistor is very small (typically less than 1 nF) because the rising and falling time is too small and close to the parasitic ringing period.

9.2.2.3 Estimate Gate-Driver Power Loss

The total loss, P_G , in the gate-driver subsystem includes the power losses (P_{GD}) of the UCC23113 device and the power losses in the peripheral circuitry, such as the external gate-drive resistor.

The P_{GD} value is the key power loss which determines the thermal safety-related limits of the UCC23113 device, and it can be estimated by calculating losses from several components.

The first component is the static power loss, P_{GDQ} , which includes power dissipated in the input stage (P_{GDQ_IN}) as well as the quiescent power dissipated in the output stage (P_{GDQ_OUT}) when operating with a certain

switching frequency under no load. P_{GDQ_IN} is determined by I_F and V_F and is given by Equation 6. The P_{GDQ_OUT} parameter is measured on the bench with no load connected to V_{OUT} pin at a given V_{DD} , switching frequency, and ambient temperature. In this example, V_{DD} is 15 V. The current on the power supply, with PWM switching at 10 kHz, is measured to be $I_{DD} = 1.33$ mA. Therefore, use Equation 7 to calculate P_{GDQ_OUT} .

$$P_{GDQ_IN} = \frac{1}{2} \times V_F \times I_F \quad (6)$$

$$P_{GDQ_OUT} = V_{DD} \times I_{DD} \quad (7)$$

The total quiescent power (without any load capacitance) dissipated in the gate driver is given by the sum of Equation 6 and Equation 7 as shown in Equation 8.

$$P_{GDQ} = P_{GDQ_IN} + P_{GDQ_OUT} = 10\text{mW} + 20\text{mW} = 30\text{mW} \quad (8)$$

The second component is the switching operation loss, P_{GDSW} , with a given load capacitance which the driver charges and discharges the load during each switching cycle. Use Equation 9 to calculate the total dynamic loss from load switching, P_{GSW} .

$$P_{GSW} = V_{DD} \times Q_G \times f_{SW} \quad (9)$$

where

- Q_G is the gate charge of the power transistor at V_{DD} .

So, for this example application the total dynamic loss from load switching is approximately 18 mW as calculated in Equation 10.

$$P_{GSW} = 15\text{V} \times 120\text{nC} \times 10\text{kHz} = 18\text{mW} \quad (10)$$

Q_G represents the total gate charge of the power transistor switching 520 V at 50 A, and is subject to change with different testing conditions. The UCC23113 gate-driver loss on the output stage, P_{GDO} , is part of P_{GSW} . P_{GDO} is equal to P_{GSW} if the external gate-driver resistance and power-transistor internal resistance are 0 Ω , and all the gate driver-loss will be dissipated inside the UCC23113. If an external turn-on and turn-off resistance exists, the total loss is distributed between the gate driver pull-up/down resistance, external gate resistance, and power-transistor internal resistance. Importantly, the pull-up/down resistance is a linear and fixed resistance if the source/sink current is not saturated to 5 A/5 A, however, it will be non-linear if the source/sink current is saturated. Therefore, P_{GDO} is different in these two scenarios.

Case 1 - Linear Pull-Up/Down Resistor:

$$P_{GDO} = \frac{P_{GSW}}{2} \left[\frac{R_{OH} || R_{NMOS}}{R_{OH} || R_{NMOS} + R_{GON} + R_{GFET_int}} + \frac{R_{OL}}{R_{OL} + R_{GOFF} + R_{GFET_int}} \right] \quad (11)$$

In this design example, all the predicted source and sink currents are less than 5 A and 5 A, therefore, use Equation 12 to estimate the UCC23113 gate-driver loss.

$$P_{GDO} = \frac{18\text{mW}}{2} \left[\frac{9.5\Omega || 5.1\Omega}{9.5\Omega || 5.1\Omega + 5.1\Omega + 0\Omega} + \frac{0.4\Omega}{0.4\Omega + 10\Omega + 0\Omega} \right] \quad (12)$$

Case 2 - Nonlinear Pull-Up/Down Resistor:

$$P_{GDO} = f_{sw} \times \left[\int_0^{T_{Rsys}} 5\text{A} \times (V_{DD} - V_{OUT}(t)) dt + \int_0^{T_{Rsys}} 5\text{A} \times V_{OUT}(t) dt \right] \quad (13)$$

where

- $V_{OUT}(t)$ is the gate-driver OUT pin voltage during the turnon and turnoff period. In cases where the output is saturated for some time, this value can be simplified as a constant-current source (5 A at turnon and 5 A at

turnoff) charging or discharging a load capacitor. Then, the $V_{OUT(t)}$ waveform will be linear and the T_{R_Sys} and T_{F_Sys} can be easily predicted.

For some scenarios, if only one of the pullup or pulldown circuits is saturated and another one is not, the P_{GDO} is a combination of case 1 and case 2, and the equations can be easily identified for the pullup and pulldown based on this discussion.

Use [Equation 14](#) to calculate the total gate-driver loss dissipated in the UCC23113 gate driver, P_{GD} .

$$P_{GD} = P_{GDQ} + P_{GDO} = 30\text{mW} + 3.9\text{mW} = 33.9\text{mW} \quad (14)$$

9.2.2.4 Estimating Junction Temperature

Use [Equation 15](#) to estimate the junction temperature (T_J) of UCC23113.

$$T_J = T_C + \Psi_{JT} \times P_{GD} \quad (15)$$

where

- T_C is the UCC23113 case-top temperature measured with a thermocouple or some other instrument.
- Ψ_{JT} is the junction-to-top characterization parameter from the table.

Using the junction-to-top characterization parameter (Ψ_{JT}) instead of the junction-to-case thermal resistance ($R_{\theta JC}$) can greatly improve the accuracy of the junction temperature estimation. The majority of the thermal energy of most ICs is released into the PCB through the package leads, whereas only a small percentage of the total energy is released through the top of the case (where thermocouple measurements are usually conducted). The $R_{\theta JC}$ resistance can only be used effectively when most of the thermal energy is released through the case, such as with metal packages or when a heat sink is applied to an IC package. In all other cases, use of $R_{\theta JC}$ will inaccurately estimate the true junction temperature. The Ψ_{JT} parameter is experimentally derived by assuming that the dominant energy leaving through the top of the IC will be similar in both the testing environment and the application environment. As long as the recommended layout guidelines are observed, junction temperature estimations can be made accurately to within a few degrees Celsius.

9.2.2.5 Selecting V_{DD} Capacitor

Bypass capacitors for V_{DD} is essential for achieving reliable performance. TI recommends choosing low-ESR and low-ESL, surface-mount, multi-layer ceramic capacitors (MLCC) with sufficient voltage ratings, temperature coefficients, and capacitance tolerances. A 50-V, 10- μF MLCC and a 50-V, 0.22- μF MLCC are selected for the C_{VDD} capacitor. If the bias power supply output is located a relatively long distance from the V_{DD} pin, a tantalum or electrolytic capacitor with a value greater than 10 μF should be used in parallel with C_{VDD} .

Note

DC bias on some MLCCs will impact the actual capacitance value. For example, a 25-V, 1- μF X7R capacitor is measured to be only 500 nF when a DC bias of 15 V_{DC} is applied.

10 Power Supply Recommendations

The recommended input supply voltage (V_{DD}) for the UCC23113 device is from 13 V to 30 V. The lower limit of the range of output bias-supply voltage (V_{DD}) is determined by the internal UVLO protection feature of the device. V_{DD} voltage should not fall below the UVLO threshold for normal operation, or else the gate-driver outputs can become clamped low for more than 20 μ s by the UVLO protection feature. The higher limit of the V_{DD} range depends on the maximum gate voltage of the power device that is driven by the UCC23113 device, and should not exceed the recommended maximum V_{DD} of 30 V. A local bypass capacitor should be placed between the V_{DD} and V_{EE} pins, with a value of 220 nF to 10 μ F for device biasing. TI recommends placing an additional 100-nF capacitor in parallel with the device biasing capacitor for high frequency filtering. Both capacitors should be positioned as close to the device as possible. Low-ESR, ceramic surface-mount capacitors are recommended.

If only a single, primary-side power supply is available in an application, isolated power can be generated for the secondary side with the help of a transformer driver such as Texas Instruments' [SN6501](#) or [SN6505A](#). For such applications, detailed power supply design and transformer selection recommendations are available in [SN6501 Transformer Driver for Isolated Power Supplies data sheet](#) and [SN6505A Low-Noise 1-A Transformer Drivers for Isolated Power Supplies data sheet](#).

11 Layout

11.1 Layout Guidelines

Designers must pay close attention to PCB layout to achieve optimum performance for the UCC23113. Some key guidelines are:

- Component placement:
 - Low-ESR and low-ESL capacitors must be connected close to the device between the V_{DD} and V_{EE} pins to bypass noise and to support high peak currents when turning on the external power transistor.
 - To avoid large negative transients on the V_{EE} pins connected to the switch node, the parasitic inductances between the source of the top transistor and the source of the bottom transistor must be minimized.
- Grounding considerations:
 - Limiting the high peak currents that charge and discharge the transistor gates to a minimal physical area is essential. This limitation decreases the loop inductance and minimizes noise on the gate terminals of the transistors. The gate driver must be placed as close as possible to the transistors.
- High-voltage considerations:
 - To ensure isolation performance between the primary and secondary side, avoid placing any PCB traces or copper below the driver device. A PCB cutout or groove is recommended in order to prevent contamination that may compromise the isolation performance.
- Thermal considerations:
 - A large amount of power may be dissipated by the UCC23113 if the driving voltage is high, the load is heavy, or the switching frequency is high. Proper PCB layout can help dissipate heat from the device to the PCB and minimize junction-to-board thermal impedance (θ_{JB}).
 - Increasing the PCB copper connecting to the V_{DD} and V_{EE} pins is recommended, with priority on maximizing the connection to V_{EE} . However, the previously mentioned high-voltage PCB considerations must be maintained.
 - If the system has multiple layers, TI also recommends connecting the V_{DD} and V_{EE} pins to internal ground or power planes through multiple vias of adequate size. These vias should be located close to the IC pins to maximize thermal conductivity. However, keep in mind that no traces or coppers from different high voltage planes are overlapping.

11.2 Layout Example

Figure 11-1 shows a PCB layout example with the signals and key components labeled.

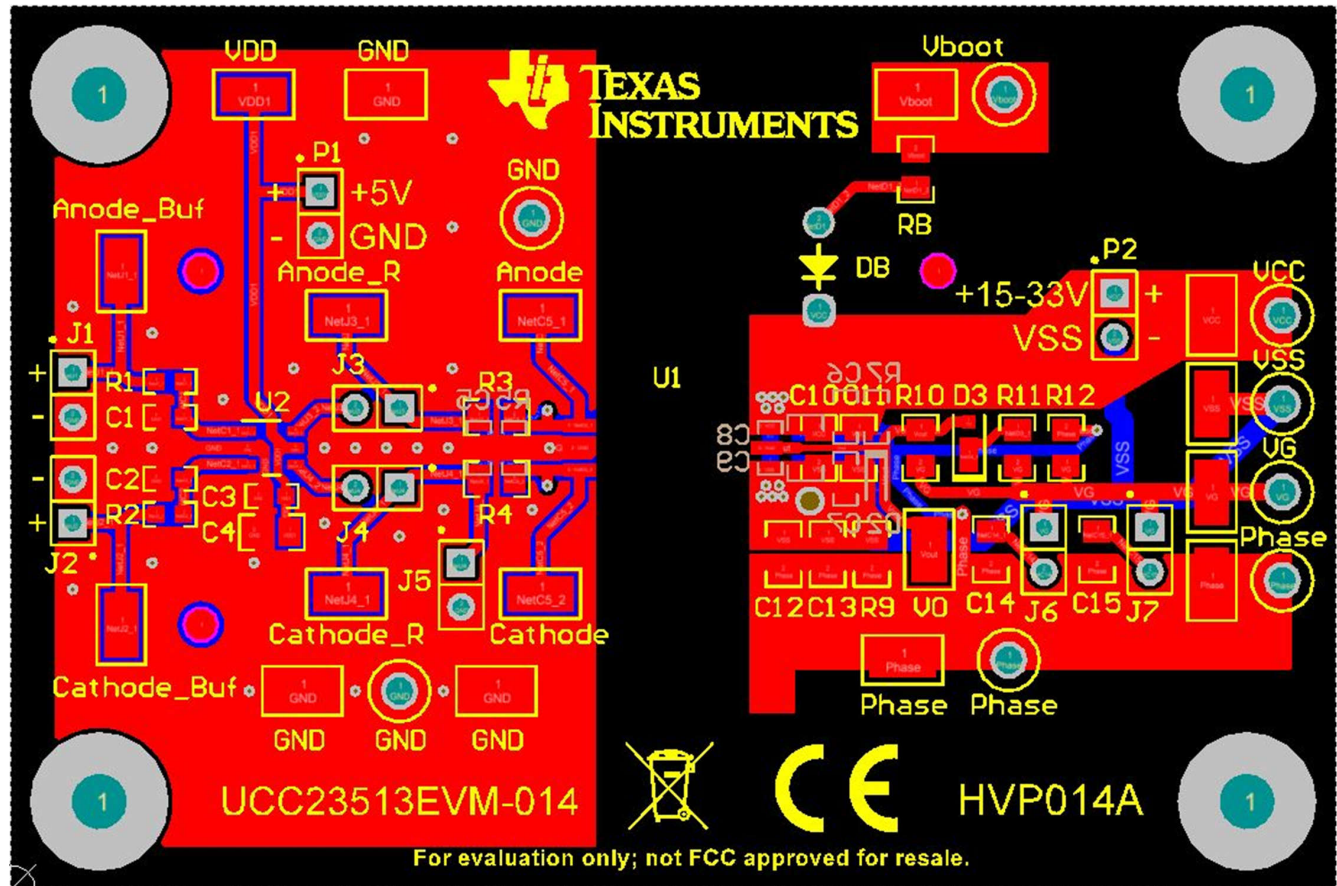

A. No PCB traces or copper are located between the primary and secondary side, which ensures isolation performance.

Figure 11-1. Layout Example

Figure 11-2 and Figure 11-3 show the top and bottom layer traces and copper.

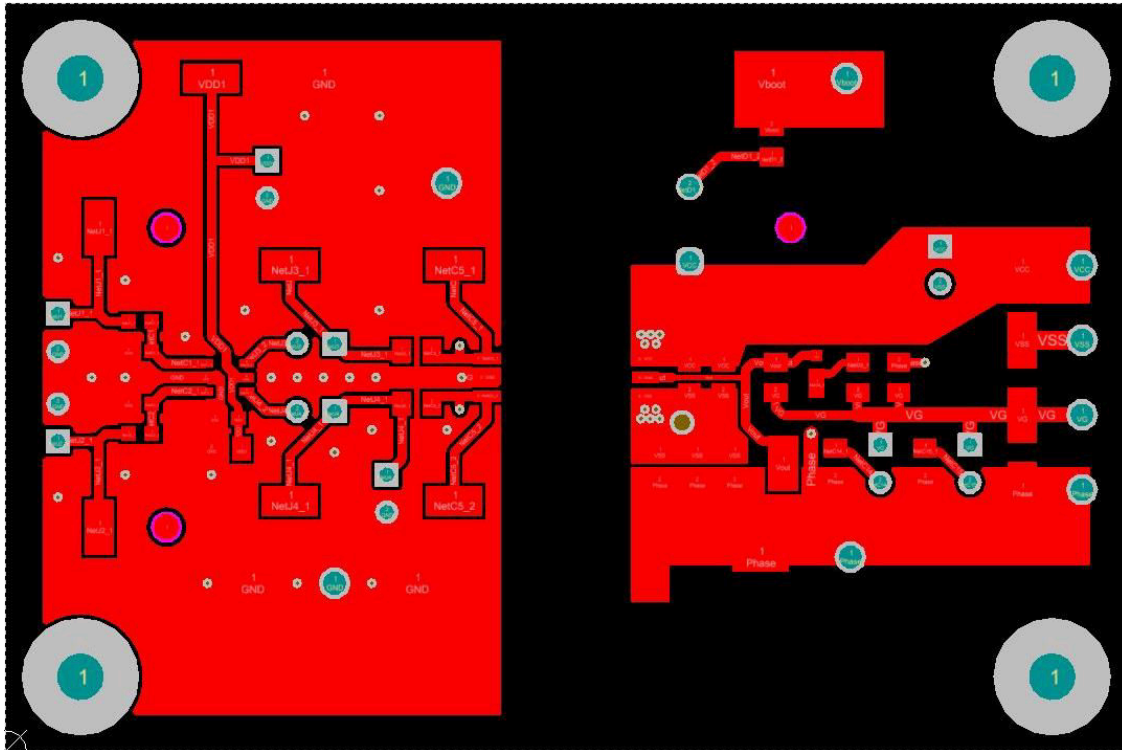

Figure 11-2. Top-Layer Traces and Copper

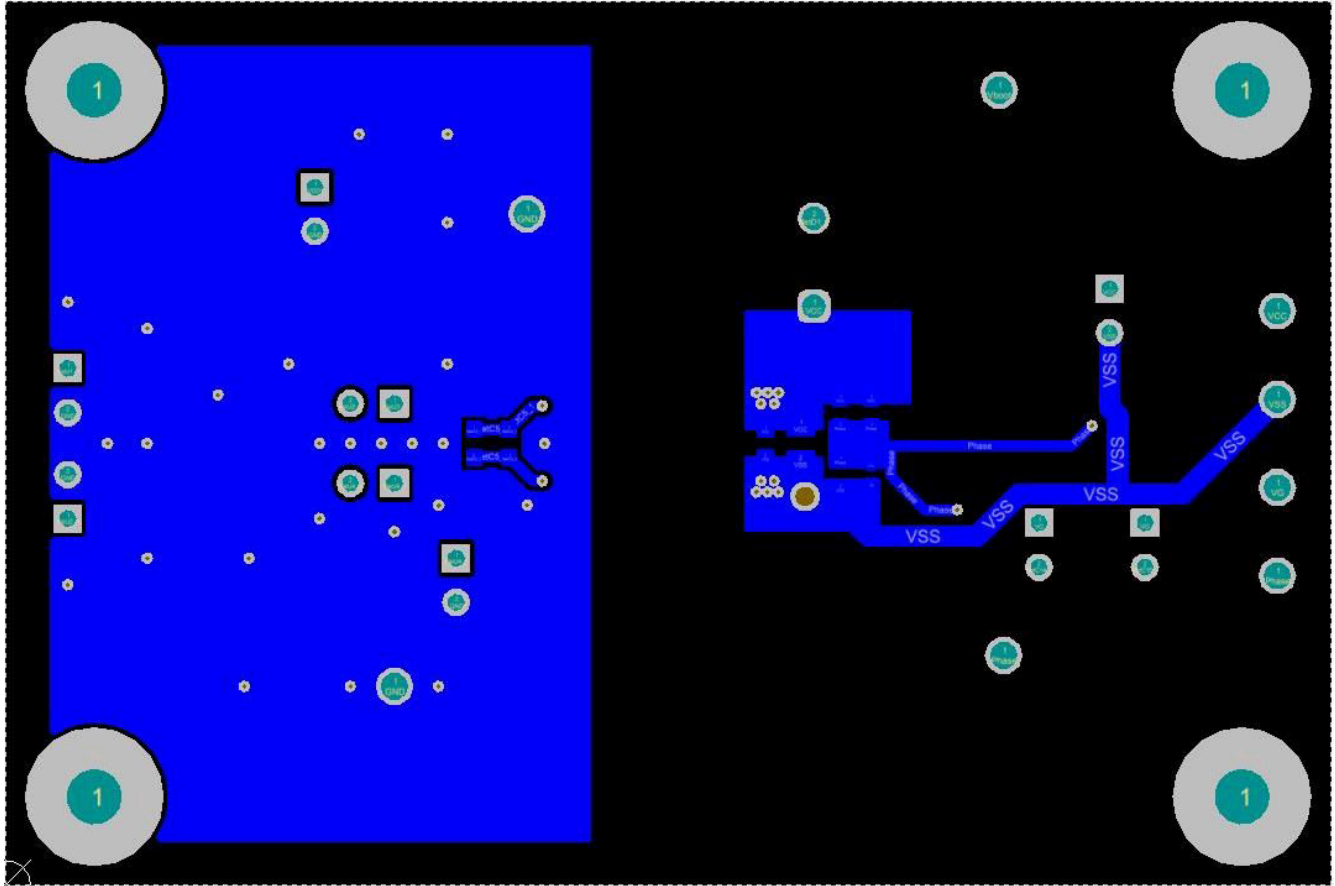

Figure 11-3. Bottom-Layer Traces and Copper (Flipped)

Figure 11-4 shows the 3D layout of the top view of the PCB.

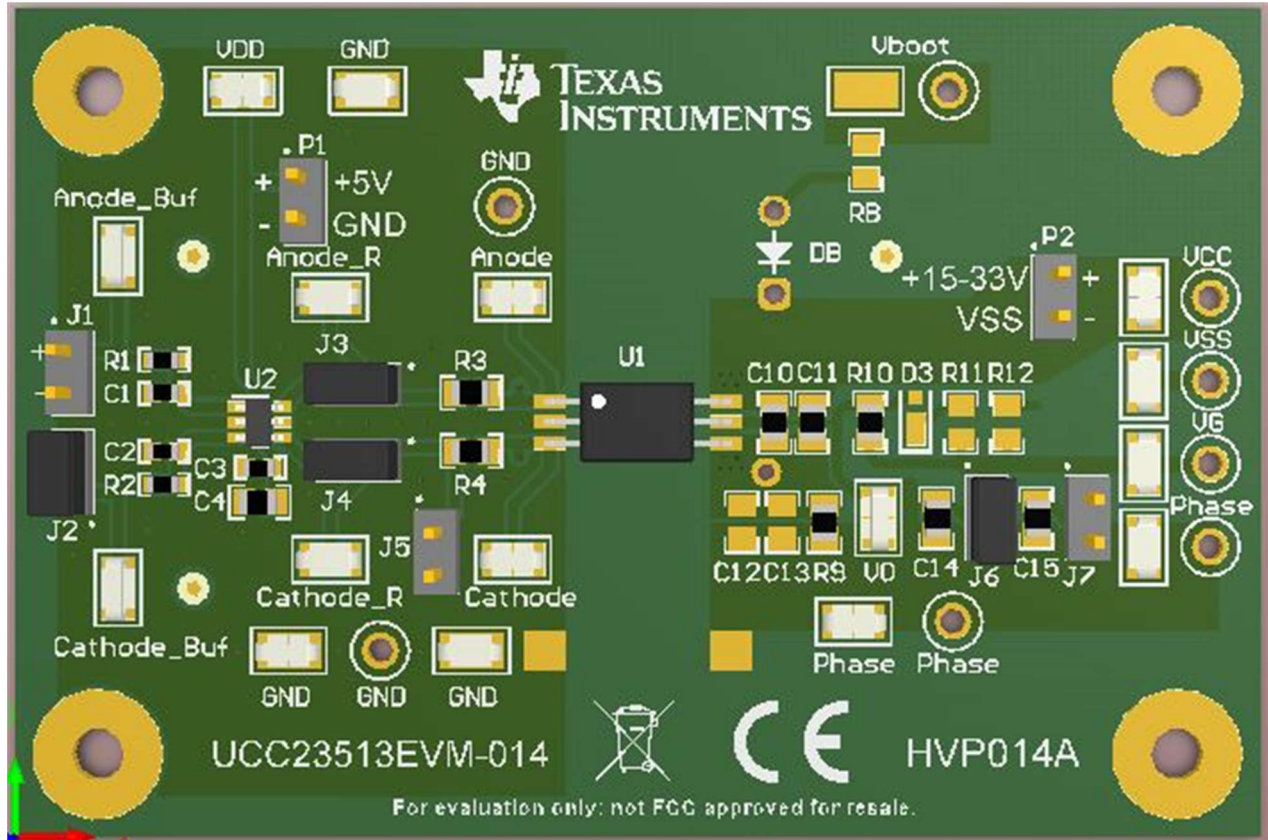

Figure 11-4. 3-D PCB View

11.3 PCB Material

Use standard FR-4 UL94V-0 printed circuit board. This PCB is preferred over cheaper alternatives because of lower dielectric losses at high frequencies, less moisture absorption, greater strength and stiffness, and the self-extinguishing flammability-characteristics.

12 Device and Documentation Support

12.1 Device Support

12.1.1 Third-Party Products Disclaimer

TI'S PUBLICATION OF INFORMATION REGARDING THIRD-PARTY PRODUCTS OR SERVICES DOES NOT CONSTITUTE AN ENDORSEMENT REGARDING THE SUITABILITY OF SUCH PRODUCTS OR SERVICES OR A WARRANTY, REPRESENTATION OR ENDORSEMENT OF SUCH PRODUCTS OR SERVICES, EITHER ALONE OR IN COMBINATION WITH ANY TI PRODUCT OR SERVICE.

12.1.2 Development Support

12.2 Documentation Support

12.2.1 Related Documentation

For related documentation see the following:

- [Digital Isolator Design Guide](#)
- [Isolation Glossary](#)
- [SN6501 Transformer Driver for Isolated Power Supplies](#)
- [SN6505A Low-Noise 1-A Transformer Drivers for Isolated Power Supplies](#)

12.3 Receiving Notification of Documentation Updates

To receive notification of documentation updates, navigate to the device product folder on [ti.com](https://www.ti.com). Click on *Subscribe to updates* to register and receive a weekly digest of any product information that has changed. For change details, review the revision history included in any revised document.

12.4 Support Resources

[TI E2E™ support forums](#) are an engineer's go-to source for fast, verified answers and design help — straight from the experts. Search existing answers or ask your own question to get the quick design help you need.

Linked content is provided "AS IS" by the respective contributors. They do not constitute TI specifications and do not necessarily reflect TI's views; see TI's [Terms of Use](#).

12.5 Trademarks

TI E2E™ is a trademark of Texas Instruments.

All trademarks are the property of their respective owners.

12.6 Electrostatic Discharge Caution



This integrated circuit can be damaged by ESD. Texas Instruments recommends that all integrated circuits be handled with appropriate precautions. Failure to observe proper handling and installation procedures can cause damage.

ESD damage can range from subtle performance degradation to complete device failure. Precision integrated circuits may be more susceptible to damage because very small parametric changes could cause the device not to meet its published specifications.

12.7 Glossary

[TI Glossary](#) This glossary lists and explains terms, acronyms, and definitions.

13 Mechanical, Packaging, and Orderable Information

The following pages include mechanical, packaging, and orderable information. This information is the most current data available for the designated devices. This data is subject to change without notice and revision of this document. For browser-based versions of this data sheet, refer to the left-hand navigation.

PACKAGING INFORMATION

Orderable part number	Status (1)	Material type (2)	Package Pins	Package qty Carrier	RoHS (3)	Lead finish/ Ball material (4)	MSL rating/ Peak reflow (5)	Op temp (°C)	Part marking (6)
UCC23113DWYR	Active	Production	SOIC (DWY) 6	850 LARGE T&R	Yes	NIPDAU	Level-2-260C-1 YEAR	-40 to 125	UCC23113
UCC23113DWYR.A	Active	Production	SOIC (DWY) 6	850 LARGE T&R	Yes	NIPDAU	Level-2-260C-1 YEAR	-40 to 125	UCC23113
UCC23113DWYR.B	Active	Production	SOIC (DWY) 6	850 LARGE T&R	Yes	NIPDAU	Level-2-260C-1 YEAR	-40 to 125	UCC23113

(1) **Status:** For more details on status, see our [product life cycle](#).

(2) **Material type:** When designated, preproduction parts are prototypes/experimental devices, and are not yet approved or released for full production. Testing and final process, including without limitation quality assurance, reliability performance testing, and/or process qualification, may not yet be complete, and this item is subject to further changes or possible discontinuation. If available for ordering, purchases will be subject to an additional waiver at checkout, and are intended for early internal evaluation purposes only. These items are sold without warranties of any kind.

(3) **RoHS values:** Yes, No, RoHS Exempt. See the [TI RoHS Statement](#) for additional information and value definition.

(4) **Lead finish/Ball material:** Parts may have multiple material finish options. Finish options are separated by a vertical ruled line. Lead finish/Ball material values may wrap to two lines if the finish value exceeds the maximum column width.

(5) **MSL rating/Peak reflow:** The moisture sensitivity level ratings and peak solder (reflow) temperatures. In the event that a part has multiple moisture sensitivity ratings, only the lowest level per JEDEC standards is shown. Refer to the shipping label for the actual reflow temperature that will be used to mount the part to the printed circuit board.

(6) **Part marking:** There may be an additional marking, which relates to the logo, the lot trace code information, or the environmental category of the part.

Multiple part markings will be inside parentheses. Only one part marking contained in parentheses and separated by a "-" will appear on a part. If a line is indented then it is a continuation of the previous line and the two combined represent the entire part marking for that device.

Important Information and Disclaimer: The information provided on this page represents TI's knowledge and belief as of the date that it is provided. TI bases its knowledge and belief on information provided by third parties, and makes no representation or warranty as to the accuracy of such information. Efforts are underway to better integrate information from third parties. TI has taken and continues to take reasonable steps to provide representative and accurate information but may not have conducted destructive testing or chemical analysis on incoming materials and chemicals. TI and TI suppliers consider certain information to be proprietary, and thus CAS numbers and other limited information may not be available for release.

In no event shall TI's liability arising out of such information exceed the total purchase price of the TI part(s) at issue in this document sold by TI to Customer on an annual basis.

TAPE AND REEL INFORMATION

QUADRANT ASSIGNMENTS FOR PIN 1 ORIENTATION IN TAPE



*All dimensions are nominal

Device	Package Type	Package Drawing	Pins	SPQ	Reel Diameter (mm)	Reel Width W1 (mm)	A0 (mm)	B0 (mm)	K0 (mm)	P1 (mm)	W (mm)	Pin1 Quadrant
UCC23113DWYR	SOIC	DWY	6	850	330.0	16.4	12.15	5.0	3.9	16.0	16.0	Q1

TAPE AND REEL BOX DIMENSIONS

*All dimensions are nominal

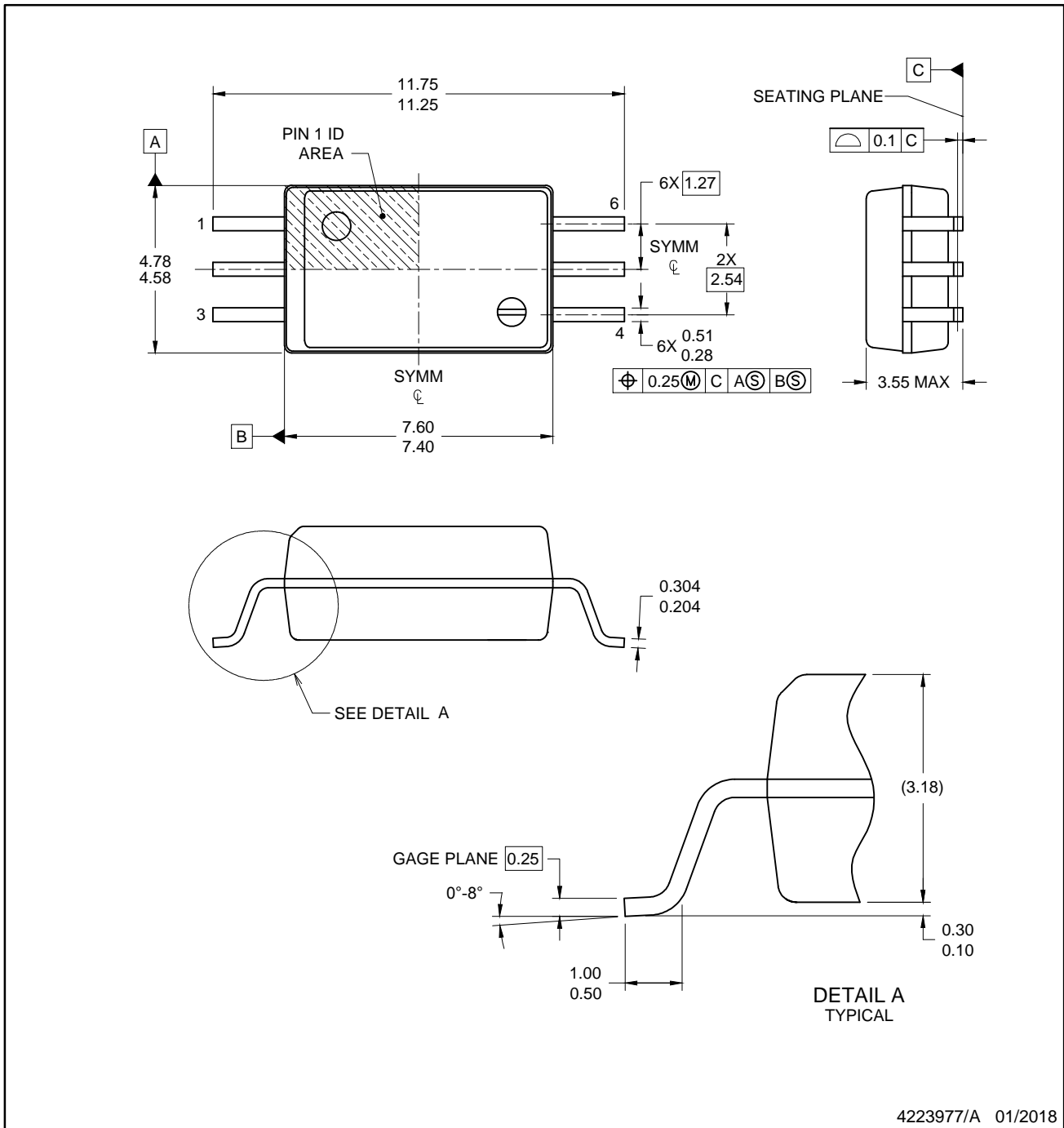
Device	Package Type	Package Drawing	Pins	SPQ	Length (mm)	Width (mm)	Height (mm)
UCC23113DWYR	SOIC	DWY	6	850	356.0	356.0	35.0



4223977/A 01/2018

NOTES:

- All linear dimensions are in millimeters. Any dimensions in parenthesis are for reference only. Dimensioning and tolerancing per ASME Y14.5M.
- This drawing is subject to change without notice.
- This dimension does not include mold flash, protrusions, or gate burrs. Mold flash, protrusions, or gate burrs shall not exceed 0.15 per side.
- This dimension does not include interlead flash. Interlead flash shall not exceed 0.70 per side.

EXAMPLE BOARD LAYOUT

SOIC - 3.55 mm max height

DWY0006A

SOIC

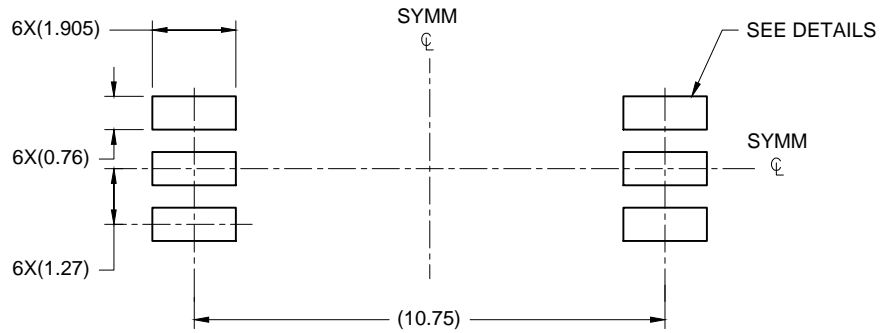

LAND PATTERN EXAMPLE
SCALE:6X

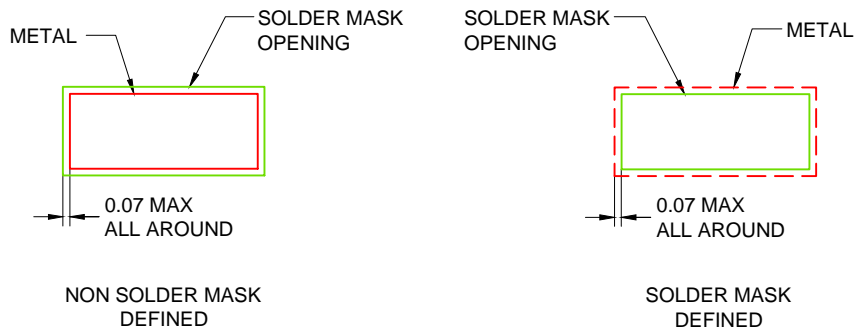

SOLDER MASK DETAILS

4223977/A 01/2018

NOTES: (continued)

5. Publication IPC-7351 may have alternate designs.
6. Solder mask tolerances between and around signal pads can vary based on board fabrication site.

EXAMPLE STENCIL DESIGN

SOIC - 3.55 mm max height

DWY0006A

SOIC

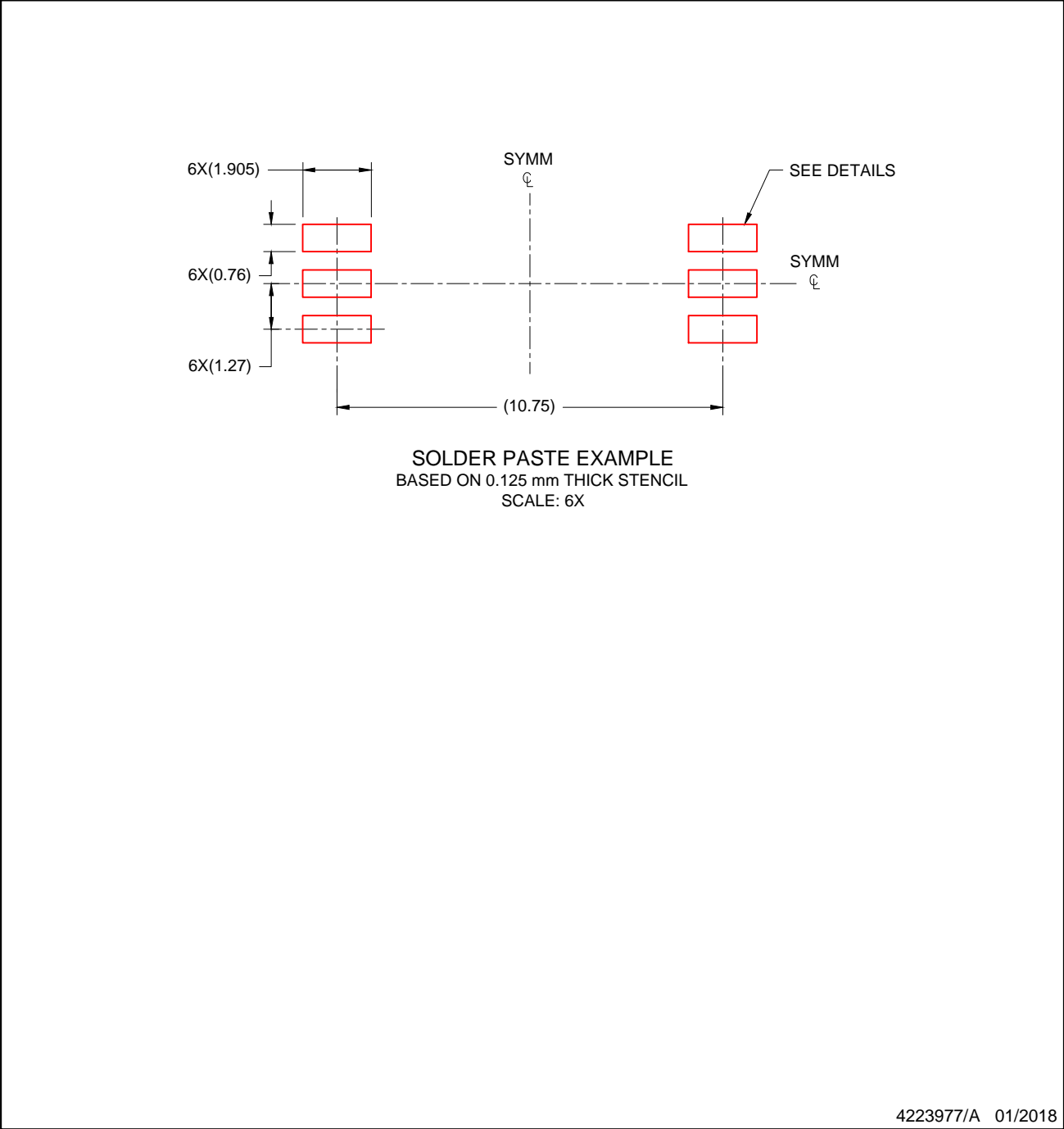

NOTES: (continued)

- 7. Laser cutting apertures with trapezoidal walls and rounded corners may offer better paste release. IPC-7525 may have alternate design recommendations.
- 8. Board assembly site may have different recommendations for stencil design.

IMPORTANT NOTICE AND DISCLAIMER

TI PROVIDES TECHNICAL AND RELIABILITY DATA (INCLUDING DATA SHEETS), DESIGN RESOURCES (INCLUDING REFERENCE DESIGNS), APPLICATION OR OTHER DESIGN ADVICE, WEB TOOLS, SAFETY INFORMATION, AND OTHER RESOURCES "AS IS" AND WITH ALL FAULTS, AND DISCLAIMS ALL WARRANTIES, EXPRESS AND IMPLIED, INCLUDING WITHOUT LIMITATION ANY IMPLIED WARRANTIES OF MERCHANTABILITY, FITNESS FOR A PARTICULAR PURPOSE OR NON-INFRINGEMENT OF THIRD PARTY INTELLECTUAL PROPERTY RIGHTS.

These resources are intended for skilled developers designing with TI products. You are solely responsible for (1) selecting the appropriate TI products for your application, (2) designing, validating and testing your application, and (3) ensuring your application meets applicable standards, and any other safety, security, regulatory or other requirements.

These resources are subject to change without notice. TI grants you permission to use these resources only for development of an application that uses the TI products described in the resource. Other reproduction and display of these resources is prohibited. No license is granted to any other TI intellectual property right or to any third party intellectual property right. TI disclaims responsibility for, and you will fully indemnify TI and its representatives against, any claims, damages, costs, losses, and liabilities arising out of your use of these resources.

TI's products are provided subject to [TI's Terms of Sale](#) or other applicable terms available either on [ti.com](https://www.ti.com) or provided in conjunction with such TI products. TI's provision of these resources does not expand or otherwise alter TI's applicable warranties or warranty disclaimers for TI products.

TI objects to and rejects any additional or different terms you may have proposed.

Mailing Address: Texas Instruments, Post Office Box 655303, Dallas, Texas 75265

Copyright © 2025, Texas Instruments Incorporated