

# AMC0x11S-Q1 Automotive, Precision, 2.25V Input, Basic and Reinforced Isolated Amplifiers With Fixed-Gain and Single-Ended Output

## 1 Features

- AEC-Q100 qualified for automotive applications:
  - Temperature grade 1:  $-40^{\circ}\text{C}$  to  $+125^{\circ}\text{C}$ ,  $T_A$
- Linear input voltage range: 0 to 2.25V
- High input impedance: 2.4G $\Omega$  (typical)
- Supply voltage range:
  - High-side (VDD1): 3.0V to 5.5V
  - Low-side (VDD2): 3.0V to 5.5V
- Fixed gain: 1V/V
- Single-ended output
- Low DC errors:
  - Offset error:  $\pm 1\text{mV}$  (maximum)
  - Offset drift:  $\pm 30\mu\text{V}/^{\circ}\text{C}$  (maximum)
  - Gain error:  $\pm 0.25\%$  (maximum)
  - Gain drift:  $\pm 50\text{ppm}/^{\circ}\text{C}$  (maximum)
  - Nonlinearity:  $\pm 0.08\%$  (maximum)
- High CMTI: 150V/ns (minimum)
- Low EMI: Meets CISPR-11 and CISPR-25 standards
- Isolation ratings:
  - AMC0211S-Q1: Basic isolation
  - AMC0311S-Q1: Reinforced Isolation
- Safety-related certifications:
  - DIN EN IEC 60747-17 (VDE 0884-17)
  - UL1577

## 2 Applications

- [Traction inverters](#)
- [Onboard chargers](#)
- [DC/DC converters](#)

## 3 Description

The AMC0x11S-Q1 is a precision, galvanically isolated amplifier with a 2.25V, high impedance input, fixed-gain, and single-ended output. The high-impedance input is optimized for connection to a high-impedance resistive divider or other voltage signal source with high output resistance.

The isolation barrier separates parts of the system that operate on different common-mode voltage levels. The isolation barrier is highly resistant to magnetic interference. This barrier is certified to provide reinforced isolation up to 5kV<sub>RMS</sub> (DWV package) and basic isolation up to 3kV<sub>RMS</sub> (D package) (60s).

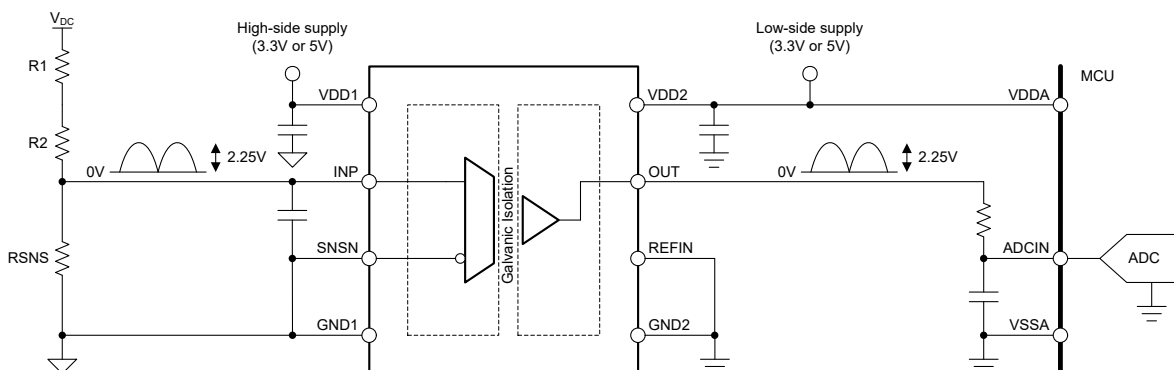
The AMC0x11S-Q1 outputs a single-ended signal proportional to the input voltage with a fixed gain of 1V/V. The output is designed to connect directly to the input of an ADC. The voltage applied to the REFIN pin sets the output voltage at 0V input.

The AMC0x11S-Q1 devices come in 8-pin, wide- and narrow-body SOIC packages, and are fully specified over the temperature range from  $-40^{\circ}\text{C}$  to  $+125^{\circ}\text{C}$ .

### Package Information

PART NUMBER	PACKAGE <sup>(1)</sup>	PACKAGE SIZE <sup>(2)</sup>
AMC0211S-Q1 <sup>(3)</sup>	D (SOIC 8)	4.9mm × 6.0mm
AMC0311S-Q1	DWV (SOIC 8)	5.85mm × 11.5mm

- (1) For more information, see the *Mechanical, Packaging, and Orderable Information* addendum.
- (2) The package size (length × width) is a nominal value and includes pins, where applicable.
- (3) PRODUCT PREVIEW



**Typical Application**



## Table of Contents

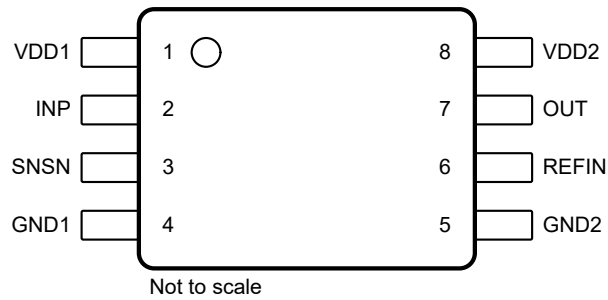
<b>1 Features</b> .....	1	6.17 Typical Characteristics.....	15
<b>2 Applications</b> .....	1	<b>7 Detailed Description</b> .....	17
<b>3 Description</b> .....	1	7.1 Overview.....	17
<b>4 Device Comparison Table</b> .....	2	7.2 Functional Block Diagram.....	17
<b>5 Pin Configuration and Functions</b> .....	3	7.3 Feature Description.....	18
<b>6 Specifications</b> .....	4	7.4 Device Functional Modes.....	20
6.1 Absolute Maximum Ratings .....	4	<b>8 Application and Implementation</b> .....	21
6.2 ESD Ratings.....	4	8.1 Application Information.....	21
6.3 Recommended Operating Conditions .....	4	8.2 Typical Application.....	21
6.4 Thermal Information (D Package).....	5	8.3 Best Design Practices.....	24
6.5 Thermal Information (DWV Package).....	5	8.4 Power Supply Recommendations.....	25
6.6 Power Ratings .....	5	8.5 Layout.....	25
6.7 Insulation Specifications (Basic Isolation).....	6	<b>9 Device and Documentation Support</b> .....	26
6.8 Insulation Specifications (Reinforced Isolation).....	7	9.1 Documentation Support.....	26
6.9 Safety-Related Certifications (Basic Isolation).....	8	9.2 Receiving Notification of Documentation Updates....	26
6.10 Safety-Related Certifications (Reinforced Isolation).....	9	9.3 Support Resources.....	26
6.11 Safety Limiting Values (D Package).....	10	9.4 Trademarks.....	26
6.12 Safety Limiting Values (DWV Package).....	11	9.5 Electrostatic Discharge Caution.....	26
6.13 Electrical Characteristics .....	12	9.6 Glossary.....	26
6.14 Switching Characteristics .....	13	<b>10 Revision History</b> .....	26
6.15 Timing Diagram.....	13	<b>11 Mechanical, Packaging, and Orderable Information</b> .....	26
6.16 Insulation Characteristics Curves.....	14		

## 4 Device Comparison Table

PARAMETER	AMC0211S-Q1 <sup>(1)</sup>	AMC0311S-Q1
Isolation rating per VDE 0884-17	Basic	Reinforced
Package	Narrow-body SOIC (D)	Wide-body SOIC (DWV)

(1) PRODUCT PREVIEW

## 5 Pin Configuration and Functions



**Figure 5-1. DWV and D Package, 8-pin SOIC (Top View)**

**Table 5-1. Pin Functions**

PIN		TYPE	DESCRIPTION
NO.	NAME		
1	VDD1	High-side power	High-side power supply <sup>(1)</sup>
2	INP	Analog input	Analog input
3	SNSN	Analog input	GND1 sense pin and inverting analog input to the modulator. Connect to GND1.
4	GND1	High-side ground	High-side analog ground
5	GND2	Low-side ground	Low-side analog ground
6	REFIN	Analog input	The voltage applied to this pin is added as an offset to the output voltage of the device. Internally, a 90kΩ resistor is connected from REFIN to GND2. Connect to GND2 if not used.
7	OUT	Analog output	Analog output
8	VDD2	Low-side power	Low-side power supply <sup>(1)</sup>

(1) See the [Power Supply Recommendations](#) section for power-supply decoupling recommendations.

## 6 Specifications

### 6.1 Absolute Maximum Ratings

over operating free-air temperature range (unless otherwise noted)<sup>(1)</sup>

		MIN	MAX	UNIT
Power-supply voltage	High-side VDD1 to GND1	-0.3	6.5	V
	Low-side VDD2 to GND2	-0.3	6.5	
Analog input voltage	INP, SNSN to GND1	GND1 - 3	VDD1 + 0.5	V
Reference input voltage	REFIN to GND2	GND2 - 0.5	VDD2 + 0.5	V
Input current	Continuous, any pin except power-supply pins	-10	10	mA
Temperature	Junction, T <sub>J</sub>		150	°C
	Storage, T <sub>stg</sub>	-65	150	

- (1) Operation outside the *Absolute Maximum Ratings* may cause permanent device damage. *Absolute Maximum Ratings* do not imply functional operation of the device at these or any other conditions beyond those listed under *Recommended Operating Conditions*. If used outside the Recommended Operating Conditions but within the Absolute Maximum Ratings, the device may not be fully functional, and this may affect device reliability, functionality, performance, and shorten the device lifetime.

### 6.2 ESD Ratings

			VALUE	UNIT
V <sub>(ESD)</sub>	Electrostatic discharge	Human-body model (HBM), per AEC Q100-002 <sup>(1)</sup> , HBM ESD classification level 2	±2000	V
		Charged-device model (CDM), per AEC Q100-011, CDM ESD classification level C6	±1000	

- (1) AEC Q100-002 indicates that HBM stressing shall be in accordance with the ANSI/ESDA/JEDEC JS-001 specification.

### 6.3 Recommended Operating Conditions

over operating ambient temperature range (unless otherwise noted)

				MIN	NOM	MAX	UNIT
<b>POWER SUPPLY</b>							
VDD1	High-side power supply	VDD1 to GND1		3	5.0	5.5	V
VDD2	Low-side power supply	VDD2 to GND2		3	3.3	5.5	V
<b>ANALOG INPUT</b>							
V <sub>Clipping</sub>	Nominal input voltage before clipping output	$V_{IN} = V_{INP} - V_{SNSN}$		0		2.56	V
V <sub>FSR</sub>	Specified linear input voltage	$V_{IN} = V_{INP} - V_{SNSN}$		0 <sup>(1)</sup>		2.25	V
V <sub>REFIN</sub>	Reference input voltage	REFIN to GND2		0		VDD2	V
<b>ANALOG OUTPUT</b>							
C <sub>LOAD</sub>	Capacitive load	OUT to GND2				500	pF
R <sub>LOAD</sub>	Resistive load	OUT to GND2			10	1	kΩ
<b>TEMPERATURE RANGE</b>							
T <sub>A</sub>	Specified ambient temperature			-40		125	°C

- (1) See the *Analog Output* section for details.

## 6.4 Thermal Information (D Package)

THERMAL METRIC <sup>(1)</sup>		D (SOIC)	UNIT
		8 PINS	
$R_{\theta JA}$	Junction-to-ambient thermal resistance	116.5	°C/W
$R_{\theta JC(top)}$	Junction-to-case (top) thermal resistance	52.8	°C/W
$R_{\theta JB}$	Junction-to-board thermal resistance	58.9	°C/W
$\Psi_{JT}$	Junction-to-top characterization parameter	19.4	°C/W
$\Psi_{JB}$	Junction-to-board characterization parameter	58.0	°C/W
$R_{\theta JC(bot)}$	Junction-to-case (bottom) thermal resistance	N/A	°C/W

(1) For more information about traditional and new thermal metrics, see the [Semiconductor and IC Package Thermal Metrics](#) application note.

## 6.5 Thermal Information (DWV Package)

THERMAL METRIC <sup>(1)</sup>		DWV (SOIC)	UNIT
		8 PINS	
$R_{\theta JA}$	Junction-to-ambient thermal resistance	102.8	°C/W
$R_{\theta JC(top)}$	Junction-to-case (top) thermal resistance	45.1	°C/W
$R_{\theta JB}$	Junction-to-board thermal resistance	63.0	°C/W
$\Psi_{JT}$	Junction-to-top characterization parameter	14.3	°C/W
$\Psi_{JB}$	Junction-to-board characterization parameter	61.1	°C/W
$R_{\theta JC(bot)}$	Junction-to-case (bottom) thermal resistance	N/A	°C/W

(1) For more information about traditional and new thermal metrics, see the [Semiconductor and IC Package Thermal Metrics](#) application note.

## 6.6 Power Ratings

PARAMETER	TEST CONDITIONS	VALUE	UNIT
$P_D$	Maximum power dissipation (both sides) VDD1 = VDD2 = 5.5V	72	mW
$P_{D1}$	Maximum power dissipation (high-side) VDD1 = 5.5V	33	mW
$P_{D2}$	Maximum power dissipation (low-side) VDD2 = 5.5V	39	mW

## 6.7 Insulation Specifications (Basic Isolation)

over operating ambient temperature range (unless otherwise noted)

PARAMETER		TEST CONDITIONS	VALUE	UNIT
<b>GENERAL</b>				
CLR	External clearance <sup>(1)</sup>	Shortest pin-to-pin distance through air	≥ 4	mm
CPG	External creepage <sup>(1)</sup>	Shortest pin-to-pin distance across the package surface	≥ 4	mm
DTI	Distance through insulation	Minimum internal gap (internal clearance) of the insulation	≥ 15.4	µm
CTI	Comparative tracking index	DIN EN 60112 (VDE 0303-11); IEC 60112	≥ 600	V
	Material group	According to IEC 60664-1	I	
	Overvoltage category per IEC 60664-1	Rated mains voltage ≤ 300V <sub>RMS</sub>	I-IV	
		Rated mains voltage ≤ 600V <sub>RMS</sub>	I-III	
<b>DIN EN IEC 60747-17 (VDE 0884-17)<sup>(2)</sup></b>				
V <sub>IORM</sub>	Maximum repetitive peak isolation voltage	At AC voltage	1130	V <sub>PK</sub>
V <sub>IOWM</sub>	Maximum-rated isolation working voltage	At AC voltage (sine wave)	800	V <sub>RMS</sub>
		At DC voltage	1130	V <sub>DC</sub>
V <sub>IOTM</sub>	Maximum transient isolation voltage	V <sub>TEST</sub> = V <sub>IOTM</sub> , t = 60s (qualification test), V <sub>TEST</sub> = 1.2 × V <sub>IOTM</sub> , t = 1s (100% production test)	4250	V <sub>PK</sub>
V <sub>IMP</sub>	Maximum impulse voltage <sup>(3)</sup>	Tested in air, 1.2/50µs waveform per IEC 62368-1	5000	V <sub>PK</sub>
V <sub>IOSM</sub>	Maximum surge isolation voltage <sup>(4)</sup>	Tested in oil (qualification test), 1.2/50µs waveform per IEC 62368-1	10000	V <sub>PK</sub>
q <sub>pd</sub>	Apparent charge <sup>(5)</sup>	Method a, after input/output safety test subgroups 2 and 3, V <sub>pd(ini)</sub> = V <sub>IOTM</sub> , t <sub>ini</sub> = 60s, V <sub>pd(m)</sub> = 1.2 × V <sub>IORM</sub> , t <sub>m</sub> = 10s	≤ 5	pC
		Method a, after environmental tests subgroup 1, V <sub>pd(ini)</sub> = V <sub>IOTM</sub> , t <sub>ini</sub> = 60s, V <sub>pd(m)</sub> = 1.3 × V <sub>IORM</sub> , t <sub>m</sub> = 10s	≤ 5	
		Method b1, at preconditioning (type test) and routine test, V <sub>pd(ini)</sub> = V <sub>IOTM</sub> , t <sub>ini</sub> = 1s, V <sub>pd(m)</sub> = 1.5 × V <sub>IORM</sub> , t <sub>m</sub> = 1s	≤ 5	
		Method b2, at routine test (100% production) <sup>(7)</sup> , V <sub>pd(ini)</sub> = V <sub>IOTM</sub> = V <sub>pd(m)</sub> , t <sub>ini</sub> = t <sub>m</sub> = 1s	≤ 5	
C <sub>IO</sub>	Barrier capacitance, input to output <sup>(6)</sup>	V <sub>IO</sub> = 0.5V <sub>PP</sub> at 1MHz	≈ 1.5	pF
R <sub>IO</sub>	Insulation resistance, input to output <sup>(6)</sup>	V <sub>IO</sub> = 500V at T <sub>A</sub> = 25°C	> 10 <sup>12</sup>	Ω
		V <sub>IO</sub> = 500V at 100°C ≤ T <sub>A</sub> ≤ 125°C	> 10 <sup>11</sup>	
		V <sub>IO</sub> = 500V at T <sub>S</sub> = 150°C	> 10 <sup>9</sup>	
	Pollution degree		2	
	Climatic category		55/125/21	
<b>UL1577</b>				
V <sub>ISO</sub>	Withstand isolation voltage	V <sub>TEST</sub> = V <sub>ISO</sub> , t = 60s (qualification test), V <sub>TEST</sub> = 1.2 × V <sub>ISO</sub> , t = 1s (100% production test)	3000	V <sub>RMS</sub>

- (1) Apply creepage and clearance requirements according to the specific equipment isolation standards of an application. Maintain the creepage and clearance distance of a board design to make sure that the mounting pads of the isolator on the printed circuit board (PCB) do not reduce this distance. Creepage and clearance on a PCB become equal in certain cases. Techniques such as inserting grooves, ribs, or both on a PCB are used to help increase these specifications.
- (2) This coupler is suitable for *safe electrical insulation* only within the safety ratings. Compliance with the safety ratings shall be ensured by means of suitable protective circuits.
- (3) Testing is carried out in air to determine the surge immunity of the package.
- (4) Testing is carried out in oil to determine the intrinsic surge immunity of the isolation barrier.
- (5) Apparent charge is electrical discharge caused by a partial discharge (pd).
- (6) All pins on each side of the barrier are tied together, creating a two-pin device.
- (7) Either method b1 or b2 is used in production.

## 6.8 Insulation Specifications (Reinforced Isolation)

over operating ambient temperature range (unless otherwise noted)

PARAMETER		TEST CONDITIONS	VALUE	UNIT
<b>GENERAL</b>				
CLR	External clearance <sup>(1)</sup>	Shortest pin-to-pin distance through air	≥ 8.5	mm
CPG	External creepage <sup>(1)</sup>	Shortest pin-to-pin distance across the package surface	≥ 8.5	mm
DTI	Distance through insulation	Minimum internal gap (internal clearance) of the double insulation	≥ 15.4	μm
CTI	Comparative tracking index	DIN EN 60112 (VDE 0303-11); IEC 60112	≥ 600	V
	Material group	According to IEC 60664-1	I	
	Overvoltage category per IEC 60664-1	Rated mains voltage ≤ 300V <sub>RMS</sub>	I-IV	
		Rated mains voltage ≤ 6000V <sub>RMS</sub>	I-III	
<b>DIN EN IEC 60747-17 (VDE 0884-17)<sup>(2)</sup></b>				
V <sub>IORM</sub>	Maximum repetitive peak isolation voltage	At AC voltage	2120	V <sub>PK</sub>
V <sub>IOWM</sub>	Maximum-rated isolation working voltage	At AC voltage (sine wave)	1500	V <sub>RMS</sub>
		At DC voltage	2120	V <sub>DC</sub>
V <sub>IOTM</sub>	Maximum transient isolation voltage	V <sub>TEST</sub> = V <sub>IOTM</sub> , t = 60s (qualification test), V <sub>TEST</sub> = 1.2 × V <sub>IOTM</sub> , t = 1s (100% production test)	7000	V <sub>PK</sub>
V <sub>IMP</sub>	Maximum impulse voltage <sup>(3)</sup>	Tested in air, 1.2/50μs waveform per IEC 62368-1	7700	V <sub>PK</sub>
V <sub>IOSM</sub>	Maximum surge isolation voltage <sup>(4)</sup>	Tested in oil (qualification test), 1.2/50μs waveform per IEC 62368-1	10000	V <sub>PK</sub>
q <sub>pd</sub>	Apparent charge <sup>(5)</sup>	Method a, after input/output safety test subgroups 2 and 3, V <sub>pd(ini)</sub> = V <sub>IOTM</sub> , t <sub>ini</sub> = 60s, V <sub>pd(m)</sub> = 1.2 × V <sub>IORM</sub> , t <sub>m</sub> = 10s	≤ 5	pC
		Method a, after environmental tests subgroup 1, V <sub>pd(ini)</sub> = V <sub>IOTM</sub> , t <sub>ini</sub> = 60s, V <sub>pd(m)</sub> = 1.6 × V <sub>IORM</sub> , t <sub>m</sub> = 10s	≤ 5	
		Method b1, at preconditioning (type test) and routine test, V <sub>pd(ini)</sub> = 1.2 × V <sub>IOTM</sub> , t <sub>ini</sub> = 1s, V <sub>pd(m)</sub> = 1.875 × V <sub>IORM</sub> , t <sub>m</sub> = 1s	≤ 5	
		Method b2, at routine test (100% production) <sup>(7)</sup> V <sub>pd(ini)</sub> = V <sub>pd(m)</sub> = 1.2 × V <sub>IOTM</sub> , t <sub>ini</sub> = t <sub>m</sub> = 1s	≤ 5	
C <sub>IO</sub>	Barrier capacitance, input to output <sup>(6)</sup>	V <sub>IO</sub> = 0.5V <sub>PP</sub> at 1MHz	≅ 1.5	pF
R <sub>IO</sub>	Insulation resistance, input to output <sup>(6)</sup>	V <sub>IO</sub> = 500V at T <sub>A</sub> = 25°C	> 10 <sup>12</sup>	Ω
		V <sub>IO</sub> = 500V at 100°C ≤ T <sub>A</sub> ≤ 125°C	> 10 <sup>11</sup>	
		V <sub>IO</sub> = 500V at T <sub>S</sub> = 150°C	> 10 <sup>9</sup>	
	Pollution degree		2	
	Climatic category		55/125/21	
<b>UL1577</b>				
V <sub>ISO</sub>	Withstand isolation voltage	V <sub>TEST</sub> = V <sub>ISO</sub> , t = 60s (qualification test), V <sub>TEST</sub> = 1.2 × V <sub>ISO</sub> , t = 1s (100% production test)	5000	V <sub>RMS</sub>

- (1) Apply creepage and clearance requirements according to the specific equipment isolation standards of an application. Maintain the creepage and clearance distance of a board design to make sure that the mounting pads of the isolator on the printed circuit board (PCB) do not reduce this distance. Creepage and clearance on a PCB become equal in certain cases. Techniques such as inserting grooves, ribs, or both on a PCB are used to help increase these specifications.
- (2) This coupler is suitable for *safe electrical insulation* only within the safety ratings. Compliance with the safety ratings shall be ensured by means of suitable protective circuits.
- (3) Testing is carried out in air to determine the surge immunity of the package.
- (4) Testing is carried in oil to determine the intrinsic surge immunity of the isolation barrier.
- (5) Apparent charge is electrical discharge caused by a partial discharge (pd).
- (6) All pins on each side of the barrier are tied together, creating a two-pin device.
- (7) Either method b1 or b2 is used in production.

### 6.9 Safety-Related Certifications (Basic Isolation)

VDE	UL
DIN EN IEC 60747-17 (VDE 0884-17), EN IEC 60747-17, DIN EN 61010-1 (VDE 0411-1) Clause : 6.4.3 ; 6.7.1.3 ; 6.7.2.1 ; 6.7.2.2 ; 6.7.3.4.2 ; 6.8.3.1	Recognized under 1577 component recognition and CSA component acceptance NO 5 programs
Basic insulation	Single protection
Certificate number: Pending	File number: Pending

### 6.10 Safety-Related Certifications (Reinforced Isolation)

VDE	UL
DIN EN IEC 60747-17 (VDE 0884-17), EN IEC 60747-17, DIN EN IEC 62368-1 (VDE 0868-1), EN IEC 62368-1, IEC 62368-1 Clause : 5.4.3 ; 5.4.4.4 ; 5.4.9	Recognized under 1577 component recognition and CSA component acceptance NO 5 programs
Reinforced insulation	Single protection
Certificate number: Pending	File number: Pending

## 6.11 Safety Limiting Values (D Package)

Safety limiting<sup>(1)</sup> intends to minimize potential damage to the isolation barrier upon failure of input or output circuitry. A failure of the I/O can allow low resistance to ground or the supply and, without current limiting, dissipate sufficient power to over-heat the die and damage the isolation barrier potentially leading to secondary system failures.

PARAMETER		TEST CONDITIONS	MIN	TYP	MAX	UNIT
$I_S$	Safety input, output, or supply current	$R_{\theta JA} = 116.5^\circ\text{C/W}$ , $V_{DDX} = 5.5\text{V}$ , $T_J = 150^\circ\text{C}$ , $T_A = 25^\circ\text{C}$			195	mA
$P_S$	Safety input, output, or total power	$R_{\theta JA} = 116.5^\circ\text{C/W}$ , $T_J = 150^\circ\text{C}$ , $T_A = 25^\circ\text{C}$			1070	mW
$T_S$	Maximum safety temperature				150	$^\circ\text{C}$

- (1) The maximum safety temperature,  $T_S$ , has the same value as the maximum junction temperature,  $T_J$ , specified for the device. The  $I_S$  and  $P_S$  parameters represent the safety current and safety power, respectively. Do not exceed the maximum limits of  $I_S$  and  $P_S$ . These limits vary with the ambient temperature,  $T_A$ .

The junction-to-air thermal resistance,  $R_{\theta JA}$ , in the Thermal Information table is that of a device installed on a high-K test board for leaded surface-mount packages. Use these equations to calculate the value for each parameter:

$T_J = T_A + R_{\theta JA} \times P$ , where  $P$  is the power dissipated in the device.

$T_{J(\max)} = T_S = T_A + R_{\theta JA} \times P_S$ , where  $T_{J(\max)}$  is the maximum junction temperature.

$P_S = I_S \times V_{DD_{\max}}$ , where  $V_{DD_{\max}}$  is the maximum supply voltage for high-side and low-side.

## 6.12 Safety Limiting Values (DWV Package)

Safety limiting<sup>(1)</sup> intends to minimize potential damage to the isolation barrier upon failure of input or output circuitry. A failure of the I/O can allow low resistance to ground or the supply and, without current limiting, dissipate sufficient power to over-heat the die and damage the isolation barrier potentially leading to secondary system failures.

PARAMETER		TEST CONDITIONS	MIN	TYP	MAX	UNIT
$I_S$	Safety input, output, or supply current	$R_{\theta JA} = 102.8^\circ\text{C}/\text{W}$ , $V_{DDx} = 5.5\text{V}$ , $T_J = 150^\circ\text{C}$ , $T_A = 25^\circ\text{C}$			220	mA
$P_S$	Safety input, output, or total power	$R_{\theta JA} = 102.8^\circ\text{C}/\text{W}$ , $T_J = 150^\circ\text{C}$ , $T_A = 25^\circ\text{C}$			1210	mW
$T_S$	Maximum safety temperature				150	$^\circ\text{C}$

- (1) The maximum safety temperature,  $T_S$ , has the same value as the maximum junction temperature,  $T_J$ , specified for the device. The  $I_S$  and  $P_S$  parameters represent the safety current and safety power, respectively. Do not exceed the maximum limits of  $I_S$  and  $P_S$ . These limits vary with the ambient temperature,  $T_A$ .

The junction-to-air thermal resistance,  $R_{\theta JA}$ , in the Thermal Information table is that of a device installed on a high-K test board for leaded surface-mount packages. Use these equations to calculate the value for each parameter:

$T_J = T_A + R_{\theta JA} \times P$ , where  $P$  is the power dissipated in the device.

$T_{J(\text{max})} = T_S = T_A + R_{\theta JA} \times P_S$ , where  $T_{J(\text{max})}$  is the maximum junction temperature.

$P_S = I_S \times V_{DD_{\text{max}}}$ , where  $V_{DD_{\text{max}}}$  is the maximum supply voltage for high-side and low-side.

### 6.13 Electrical Characteristics

minimum and maximum specifications apply from  $T_A = -40^\circ\text{C}$  to  $+125^\circ\text{C}$ ,  $V_{DD1} = 3.0\text{V}$  to  $5.5\text{V}$ ,  $V_{DD2} = 3.0\text{V}$  to  $5.5\text{V}$ ,  $V_{REFIN} = \text{GND2}$ ,  $\text{SNSN} = \text{GND1}$ ,  $V_{INP} = 0.25\text{V}$  to  $2.25\text{V}$  (unless otherwise noted); typical specifications are at  $T_A = 25^\circ\text{C}$ ,  $V_{DD1} = 5\text{V}$ , and  $V_{DD2} = 3.3\text{V}$

PARAMETER		TEST CONDITIONS	MIN	TYP	MAX	UNIT
<b>ANALOG INPUT</b>						
$C_{IN}$	Input capacitance			2		pF
$R_{INP}$	Input impedance	INP pin to GND1	0.05	2.4		$\text{G}\Omega$
$I_{IB, INP}$	Input bias current <sup>(1)</sup>	INP pin, INP = GND1	-10	$\pm 3$	10	nA
CMTI	Common-mode transient immunity		150			V/ns
<b>ANALOG OUTPUT</b>						
	Nominal gain			1		V/V
$R_{OUT}$	Output resistance	OUTP or OUTN		<0.2		$\Omega$
	Output short-circuit current	sourcing or sinking, INP = GND1, output shorted to either GND2 or VDD2		11		mA
<b>DC ACCURACY</b>						
$V_{OS}$	Input offset voltage <sup>(1) (2)</sup>	$V_{OS} = (V_{OUT} - V_{REFIN})$ , INP = SNSN = GND1, $V_{REFIN} = 250\text{mV}$ , $T_A = 25^\circ\text{C}$	-1	$\pm 0.15$	1	mV
$TCV_{OS}$	Input offset thermal drift <sup>(1) (2) (4)</sup>		-30	$\pm 3$	30	$\mu\text{V}/^\circ\text{C}$
$E_G$	Gain error <sup>(1)</sup>	$T_A = 25^\circ\text{C}$	-0.25%	$\pm 0.04\%$	0.25%	
$TCE_G$	Gain error drift <sup>(1) (5)</sup>		-50	$\pm 5$	50	ppm/ $^\circ\text{C}$
	Nonlinearity		-0.08%	$\pm 0.002\%$	0.08%	
	Output noise	INP = GND1, BW = 50kHz		180		$\mu\text{V}_{RMS}$
PSRR	Power-supply rejection ratio <sup>(2)</sup>	VDD1 DC PSRR, $V_{INP} = 250\text{mV}$ , VDD1 from 3V to 5.5V		-77		dB
		VDD1 AC PSRR, $V_{INP} = 250\text{mV}$ , VDD1 with 10kHz / 100mV ripple		-56		
		VDD2 DC PSRR, $V_{INP} = 250\text{mV}$ , VDD2 from 3V to 5.5V		-100		
		VDD2 AC PSRR, $V_{INP} = 250\text{mV}$ , VDD2 with 10kHz / 100mV ripple		-69		
<b>AC ACCURACY</b>						
BW	Output bandwidth		120	145		kHz
THD	Total harmonic distortion <sup>(3)</sup>	$V_{INP} = 2V_{PP}$ , $V_{INP} > 0\text{V}$ , $f_{IN} = 10\text{kHz}$		-83	-73	dB
SNR	Signal-to-noise ratio	$V_{INP} = 2.25V_{PP}$ , $f_{INP} = 1\text{kHz}$ , BW = 10kHz	75	80		dB
		$V_{INP} = 2.25V_{PP}$ , $f_{INP} = 10\text{kHz}$ , BW = 50kHz		70		
<b>POWER SUPPLY</b>						
$I_{DD1}$	High-side supply current			4.4	5.6	mA
$I_{DD2}$	Low-side supply current			4.8	7.4	mA
$V_{DD1_{UV}}$	High-side undervoltage detection threshold	VDD1 rising	2.4	2.6	2.8	V
		VDD1 falling	1.9	2.05	2.2	
$V_{DD2_{UV}}$	Low-side undervoltage detection threshold	VDD2 rising	2.3	2.5	2.7	V
		VDD2 falling	1.9	2.05	2.2	

(1) The typical value includes one standard deviation ( $\sigma$ ) at nominal operating conditions.

(2) This parameter is input referred.

(3) THD is the ratio of the rms sum of the amplitudes of first five higher harmonics to the amplitude of the fundamental.

(4) Offset error temperature drift is calculated using the box method, as described by the following equation:

$$TCV_{OS} = (Value_{MAX} - Value_{MIN}) / TempRange$$

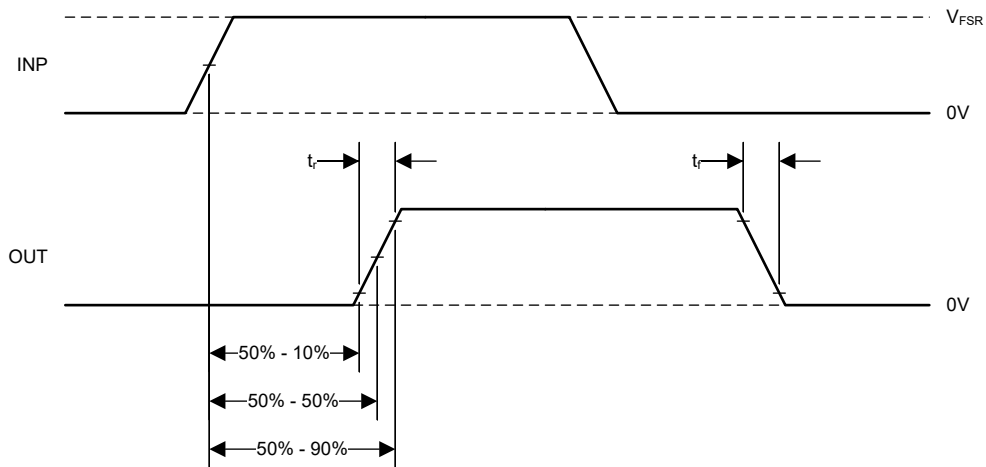
- (5) Gain error temperature drift is calculated using the box method, as described by the following equation:  
 $TCE_G (ppm) = (Value_{MAX} - Value_{MIN}) / (Value_{(T=25^{\circ}C)} \times TempRange) \times 10^6$

## 6.14 Switching Characteristics

over operating ambient temperature range (unless otherwise noted)

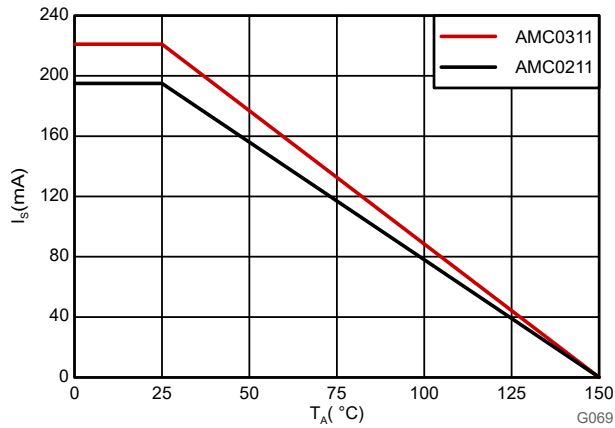
PARAMETER		TEST CONDITIONS	MIN	TYP	MAX	UNIT
$t_r$	Output signal rise time	10% to 90%, unfiltered output		2.6		$\mu s$
$t_f$	Output signal fall time	10% to 90%, unfiltered output		2.6		$\mu s$
	$V_{INP}$ to $V_{OUT}$ signal delay (50% - 10%)	Unfiltered output		1.6		$\mu s$
	$V_{INP}$ to $V_{OUT}$ signal delay (50% - 50%)	Unfiltered output		2.9	3.2	$\mu s$
	$V_{INP}$ to $V_{OUT}$ signal delay (50% - 90%)	Unfiltered output		4.3		$\mu s$
$t_{AS}$	Analog settling time	AVDD step to 3.0V with DVDD $\geq$ 3.0V to $V_{OUT}$ valid, 0.1% settling		20		$\mu s$

## 6.15 Timing Diagram

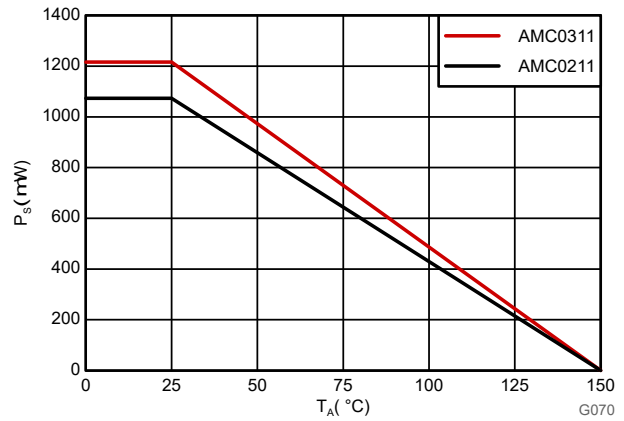


**Figure 6-1. Rise, Fall, and Delay Time Definition**

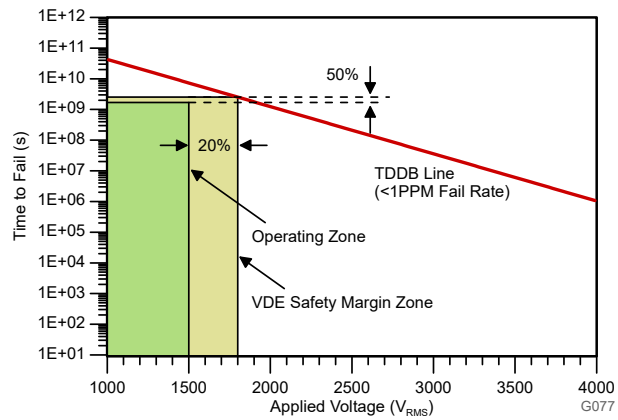
## 6.16 Insulation Characteristics Curves



**Figure 6-2. Thermal Derating Curve for Safety-Limiting Current per VDE**



**Figure 6-3. Thermal Derating Curve for Safety-Limiting Power per VDE**

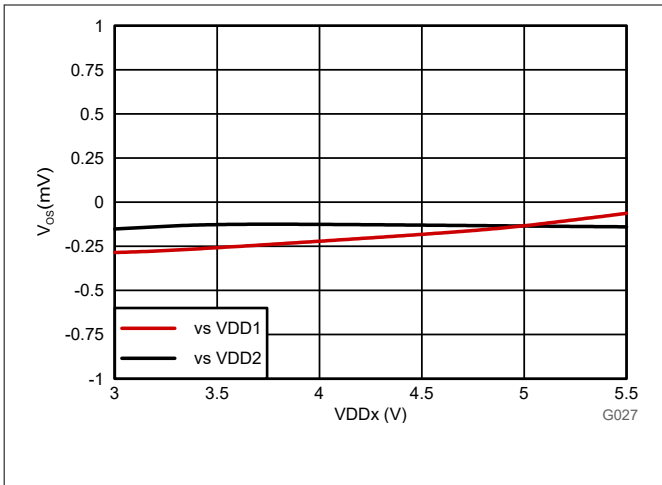


$T_A$  up to 150°C, stress-voltage frequency = 60Hz, isolation working voltage = 1500V<sub>RMS</sub>, projected operating lifetime ≥50 years

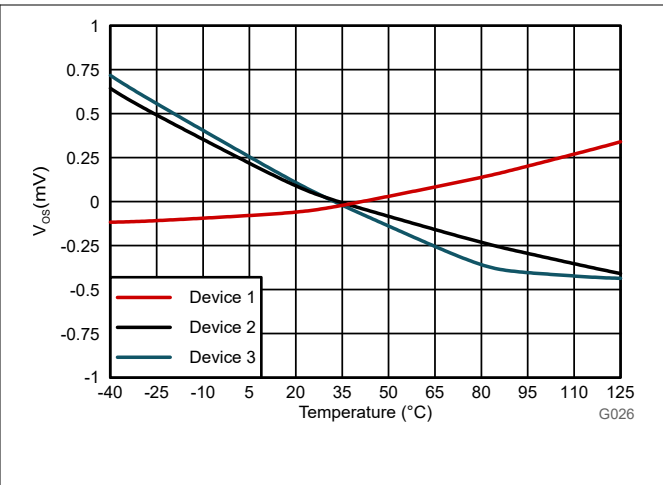
**Figure 6-4. Isolation Capacitor Lifetime Projection**

### 6.17 Typical Characteristics

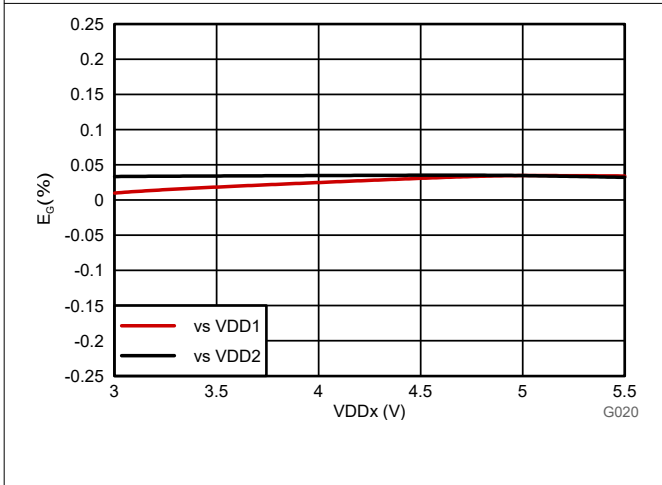
at VDD1 = 5V, VDD2 = 3.3V, SNSN = GND1, REFIN = GND2,  $f_{IN} = 10\text{kHz}$ , and BW = 100kHz (unless otherwise noted)



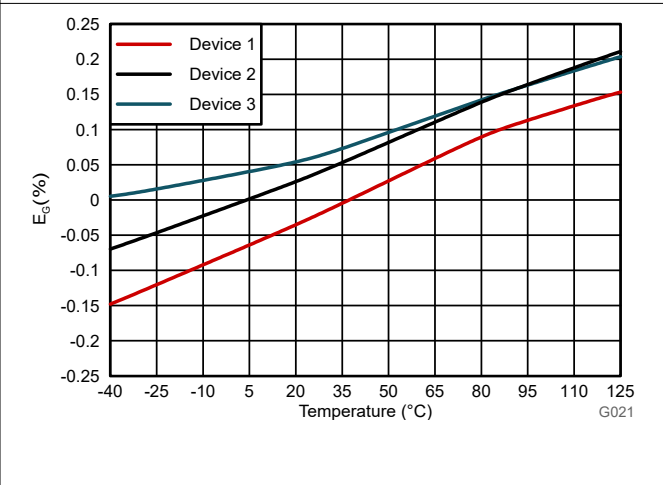
**Figure 6-5. Input Offset Voltage vs Supply Voltage**



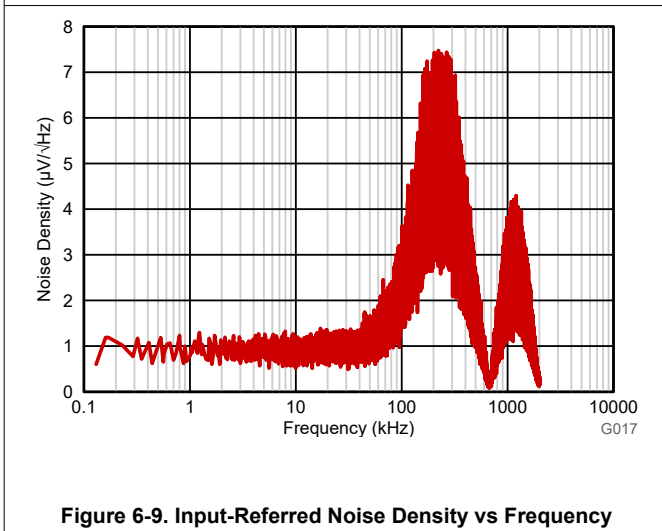
**Figure 6-6. Input Offset Voltage vs Temperature**



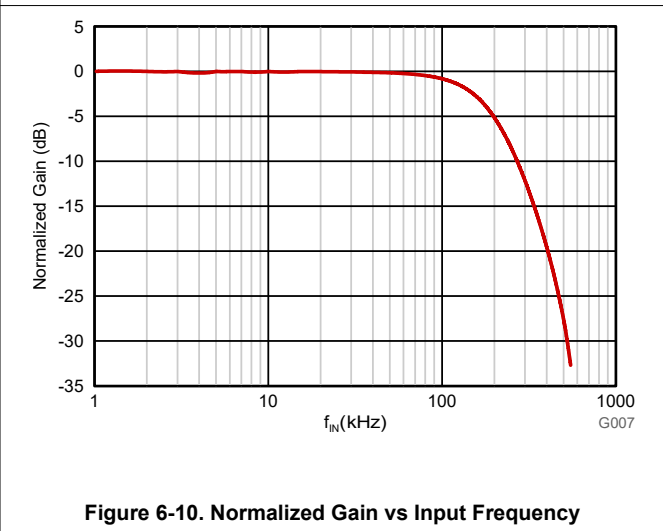
**Figure 6-7. Gain Error vs Supply Voltage**



**Figure 6-8. Gain Error vs Temperature**



**Figure 6-9. Input-Referred Noise Density vs Frequency**



**Figure 6-10. Normalized Gain vs Input Frequency**

### 6.17 Typical Characteristics (continued)

at VDD1 = 5V, VDD2 = 3.3V, SNSN = GND1, REFIN = GND2,  $f_{IN}$  = 10kHz, and BW = 100kHz (unless otherwise noted)

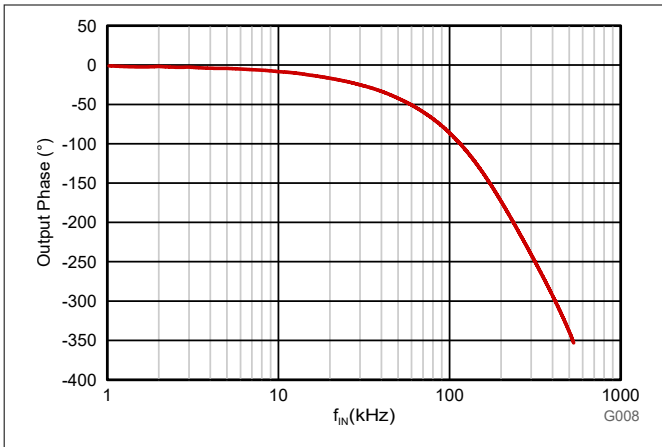


Figure 6-11. Output Phase vs Input Frequency

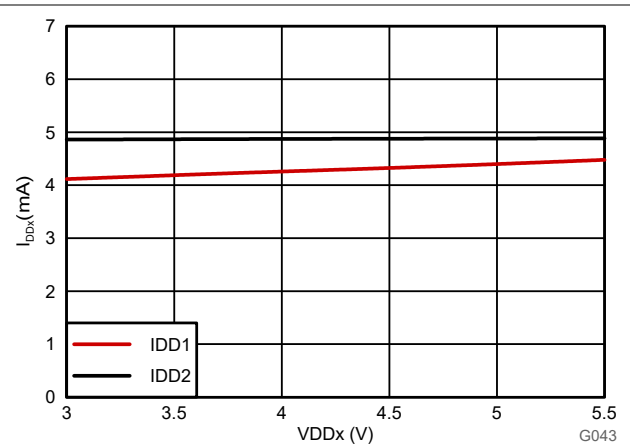


Figure 6-12. Supply Current vs Supply Voltage

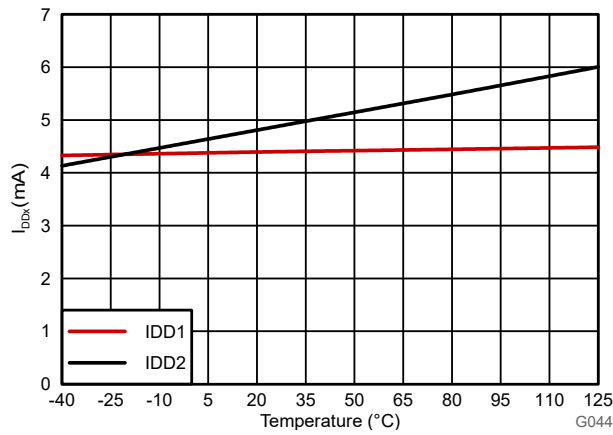


Figure 6-13. Supply Current vs Temperature

## 7 Detailed Description

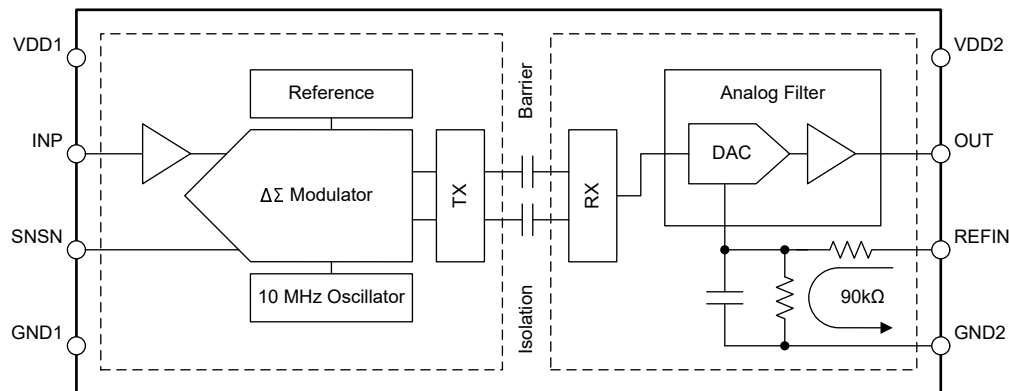
### 7.1 Overview

The AMC0x11S-Q1 is a precision, galvanically isolated amplifier with a 2.25V, high impedance input, fixed-gain, and single-ended output. The input stage of the device drives a second-order, delta-sigma ( $\Delta\Sigma$ ) modulator. The modulator converts the analog input signal into a digital bitstream that is transferred across the isolation barrier that separates the high side from the low side.

On the low-side, the received bitstream is processed by an analog filter that outputs a GND2-referenced, single-ended signal at the OUT pin. This single-ended output signal is proportional to the input signal. The output voltage at 0V input is set by the voltage applied to the REFIN pin.

The SiO<sub>2</sub>-based, capacitive isolation barrier supports a high level of magnetic field immunity, as described in the [ISO72x Digital Isolator Magnetic-Field Immunity application note](#). The digital modulation used in the AMC0x11S-Q1 transmits data across the isolation barrier. This modulation, and the isolation barrier characteristics, result in high reliability and high common-mode transient immunity.

### 7.2 Functional Block Diagram



## 7.3 Feature Description

### 7.3.1 Analog Input

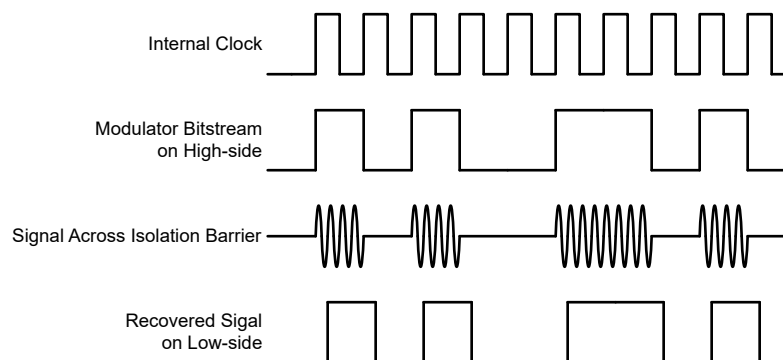
The high-impedance input buffer on the INP pin feeds a second-order, switched-capacitor, feed-forward  $\Delta\Sigma$  modulator. The modulator converts the analog signal into a bitstream that is transferred across the isolation barrier, as described in the [Isolation Channel Signal Transmission](#) section.

There are two restrictions on the analog input signal. First, if the input voltage exceeds the value specified in the [Absolute Maximum Ratings](#) table, the input current must be limited to 10mA. This limitation is caused by the device input electrostatic discharge (ESD) diodes turning on. Second, linearity and noise performance are specified only when the input voltage is within the linear full-scale range ( $V_{FSR}$ ).  $V_{FSR}$  is specified in the [Recommended Operating Conditions](#) table.

### 7.3.2 Isolation Channel Signal Transmission

As shown in [Figure 7-1](#), the AMC0x11S-Q1 uses an on-off keying (OOK) modulation scheme to transmit the modulator output bitstream across the SiO<sub>2</sub>-based isolation barrier. The transmit driver (TX) is illustrated in the [Functional Block Diagram](#). TX transmits an internally generated, high-frequency carrier across the isolation barrier to represent a digital *one*. However, TX does not send a signal to represent a digital *zero*. The nominal frequency of the carrier used inside the AMC0x11S-Q1 is 480MHz.

The receiver (RX) on the other side of the isolation barrier recovers and demodulates the signal and provides the input to the analog filter. The AMC0x11S-Q1 transmission channel is optimized to achieve the highest level of common-mode transient immunity (CMTI) and the lowest level of radiated emissions. The high-frequency carrier and RX/TX buffer switching cause these emissions.



**Figure 7-1. OOK-Based Modulation Scheme**

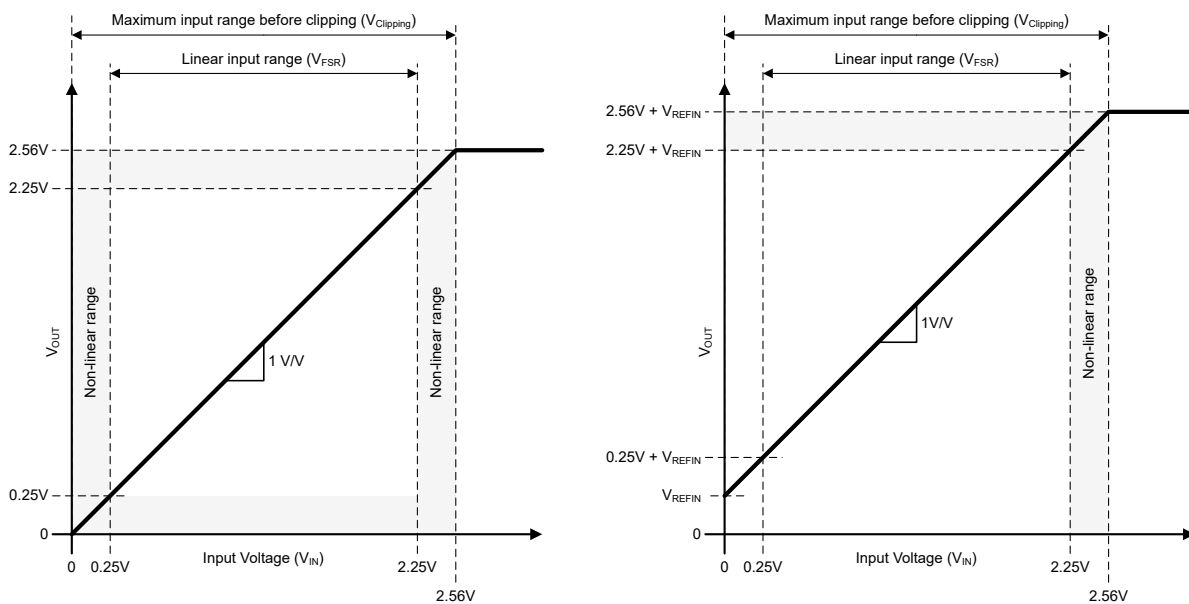
### 7.3.3 Analog Output

The AMC0x11S-Q1 provides a single-ended analog output voltage proportional to the input voltage. The output is referred to GND2 and is galvanically isolated from the input of the device. The output is designed to connect directly to the input of an ADC.

The output buffer requires a minimum headroom of 250mV for linear operation. Therefore, with REFIN shorted to GND2, the device shows non-linear behavior for input voltages near 0V. To extend the linear input range to 0V, connect a reference voltage to the REFIN pin that is  $\geq 250\text{mV}$ . The voltage applied to the REFIN pin is added to the output voltage as an offset and provides headroom for the output buffer. The output voltage of the AMC0x11S-Q1 is equal to:

$$V_{\text{OUT}} = V_{\text{IN}} + V_{\text{REFIN}} = (V_{\text{INP}} - V_{\text{SNSN}}) + V_{\text{REFIN}} \quad (1)$$

Connect the REFIN pin to GND2 if no offset is required. Figure 7-2 shows the input-to-output transfer characteristic of the device.



**Figure 7-2. Input to Output Transfer Curve of the AMC0x11S-Q1**  
 Left: REFIN shorted to GND2. Right:  $V_{\text{REFIN}} = 250\text{mV}$

### 7.3.4 Reference Input

The voltage applied to the REFIN pin is added to the output voltage as an offset as described in the [Analog Output](#) section. In a typical application, REFIN is either shorted to GND2 or biased at  $\geq 250\text{mV}$ .

The output buffer is linear in the range of  $250\text{mV} < V_{\text{OUT}} < (V_{\text{DD2}} - 250\text{mV})$ . For linear operation, bias the REFIN pin such that:

$$V_{\text{REFIN}} \geq 250\text{mV} \quad (2)$$

and

$$V_{\text{REFIN}} + V_{\text{FSR, MAX}} \leq V_{\text{DD2}} - 250\text{mV} \quad (3)$$

## 7.4 Device Functional Modes

The AMC0x11S-Q1 operates in one of the following states:

- OFF-state: The low-side supply (VDD2) is below the  $VDD2_{UV}$  threshold. The device is not responsive. OUT is in Hi-Z state. Internally, OUT is clamped to VDD2 and GND2 by ESD protection diodes.
- Missing high-side supply: The low-side of the device (VDD2) is supplied and within recommended operating conditions. The high-side supply (VDD1) is below the  $VDD1_{UV}$  threshold. The OUT pin is driven to  $V_{REFIN}$  (0V if REFIN is shorted to GND2).
- Analog input overrange (positive full-scale input): VDD1 and VDD2 are within recommended operating conditions but the analog input voltage  $V_{IN}$  is above the maximum clipping voltage  $V_{Clipping, MAX}$ . The device outputs  $V_{Clipping} + V_{REFIN}$  at the OUT pin.
- Analog input underrange (negative full-scale input): VDD1 and VDD2 are within recommended operating conditions but the analog input voltage  $V_{IN}$  is below the minimum clipping voltage  $V_{Clipping, MIN}$ . The OUT pin is driven to  $V_{REFIN}$  (0V if REFIN is shorted to GND2).
- Normal operation: VDD1, VDD2, and  $V_{IN}$  are within the recommended operating conditions. The device outputs a voltage proportional to the input voltage.

Table 7-1 lists the operating modes.

**Table 7-1. Device Operational Modes**

OPERATING CONDITION	VDD1	VDD2	$V_{IN}$	DEVICE RESPONSE
OFF	Don't care	$VDD2 < VDD2_{UV}$	Don't care	OUT is in Hi-Z state. Internally, OUT is clamped to VDD2 and GND2 by ESD protection diodes.
Missing high-side supply	$VDD1 < VDD1_{UV}$	Valid <sup>(1)</sup>	Don't care	The OUT pin is driven to $V_{REFIN}$ (0V if REFIN is shorted to GND2).
Input overrange	Valid <sup>(1)</sup>	Valid <sup>(1)</sup>	$V_{IN} > V_{Clipping, MAX}$	The device outputs $V_{Clipping} + V_{REFIN}$ at the OUT pin.
Input underrange	Valid <sup>(1)</sup>	Valid <sup>(1)</sup>	$V_{IN} < V_{Clipping, MIN}$	The OUT pin is driven to $V_{REFIN}$ (0V if REFIN is shorted to GND2).
Normal operation	Valid <sup>(1)</sup>	Valid <sup>(1)</sup>	Valid <sup>(1)</sup>	The device outputs a voltage proportional to the input voltage.

(1) "Valid" denotes within the recommended operating conditions.

## 8 Application and Implementation

### Note

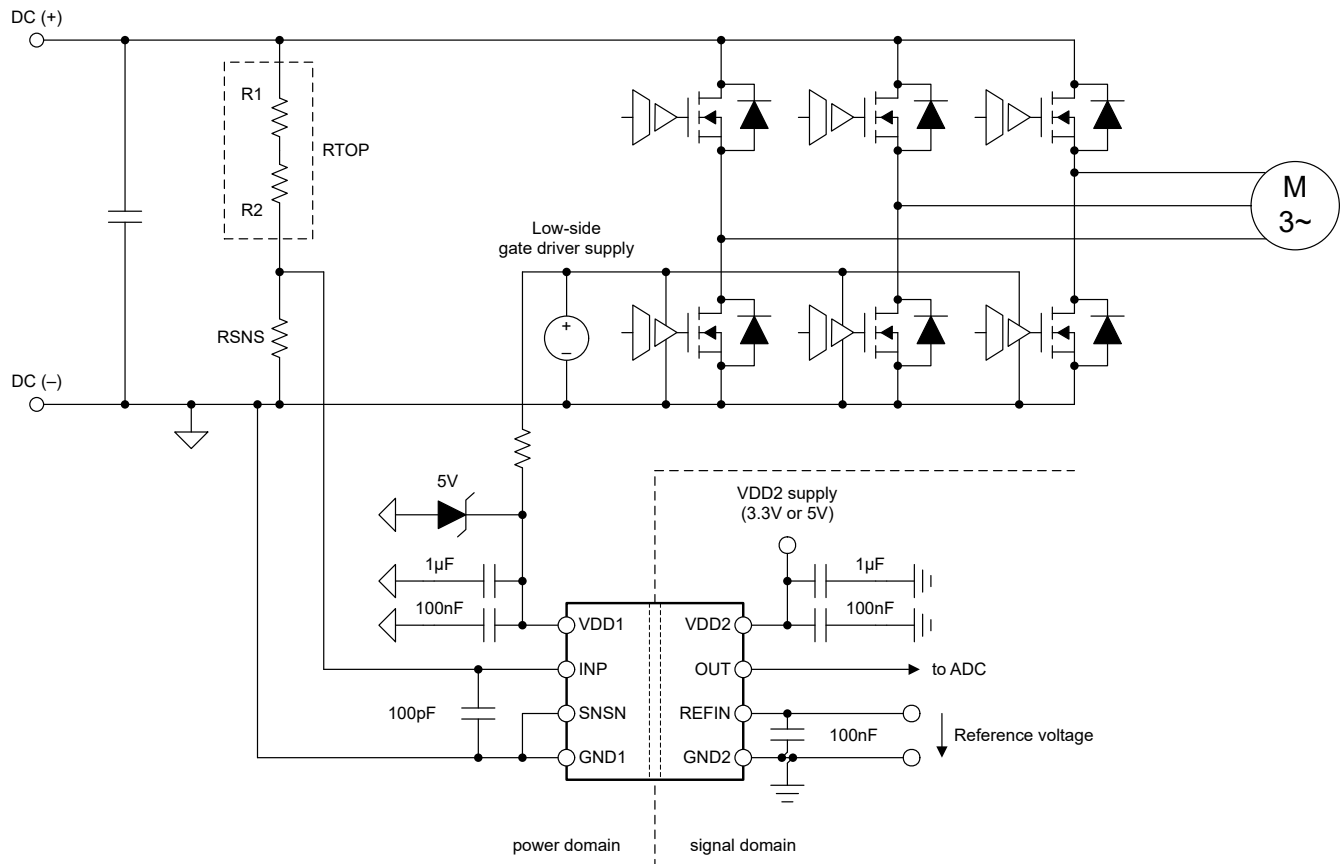
Information in the following applications sections is not part of the TI component specification, and TI does not warrant its accuracy or completeness. TI's customers are responsible for determining suitability of components for their purposes, as well as validating and testing their design implementation to confirm system functionality.

### 8.1 Application Information

Automotive power systems such as traction inverters are divided into two or more voltage domains that are galvanically isolated from each other. For example, the high-voltage domain includes the HV battery and the power stage of the traction inverter. The low-voltage domain includes the system controller and human interface. The controller must measure the value of the DC-bus voltage while remaining galvanically isolated from the high-voltage domain for safety reasons. With the high-impedance input and galvanically isolated output, the AMC0x11S-Q1 enables this measurement.

### 8.2 Typical Application

The following typical application diagram illustrates a simplified schematic of a traction inverter. The AMC0x11S-Q1 device is used for DC-Bus voltage sensing. In the power domain, the DC-Bus voltage is divided down to a 2V level across the bottom resistor (RSNS) of a high-impedance resistive divider. The voltage across RSNS is sensed by the AMC0x11S-Q1. The low-side gate driver supply is regulated to a 5V level to power the high-voltage side of the AMC0x11S-Q1. In the signal domain, on the opposite side of the isolation barrier, the AMC0x11S-Q1 outputs a voltage proportional to the DC-Bus voltage.



**Figure 8-1. Using the AMC0x11S-Q1 in a Typical Application**

### 8.2.1 Design Requirements

Table 8-1 lists the parameters for this typical application.

**Table 8-1. Design Requirements**

PARAMETER	VALUE
DC bus voltage	960V (maximum)
High-side supply voltage	5V
Low-side supply voltage	3.3V
Maximum resistor operating voltage	125V
Voltage drop across the sense resistor (RSNS) for a linear response	2.25V (maximum)
Current through the resistive divider, I <sub>CROSS</sub>	200μA (maximum)

### 8.2.2 Detailed Design Procedure

The 200μA cross-current requirement at the maximum DC bus voltage (960V) determines that the total impedance of the resistive divider is 4.80MΩ. The impedance of the resistive divider is dominated by the top portion, shown exemplarily as R1 and R2 in Figure 8-1. The maximum allowed voltage drop per unit resistor is specified as 125V. Therefore, the minimum number of unit resistors in the top portion of the resistive divider is  $960V / 125V \cong 8$ . The calculated unit value is  $4.80M\Omega / 8 = 600k\Omega$  and the next closest value from the E96 series is 604kΩ. The sense resistor (RSNS) is sized such that the voltage drop across the resistor at the maximum DC bus voltage (960V) equals the linear  $V_{FSR}$ . The linear  $V_{FSR}$  value of the AMC0x11S-Q1 is 2.25V. This resistance is calculated as  $RSNS = V_{FSR} / (V_{DC-link, MAX} - V_{FSR}) \times R_{TOP}$ .  $R_{TOP}$  is the total value of the top resistor string ( $8 \times 604k\Omega = 4.832M\Omega$ ). RSNS is calculated as 11.35kΩ. The next closest value from the E96 series is 11.3kΩ.

Table 8-2 summarizes the design of the resistive divider.

**Table 8-2. Resistor Value Examples**

PARAMETER	VALUE
Unit resistor value, R <sub>TOP</sub>	604kΩ
Number of unit resistors in R <sub>TOP</sub>	8
Sense resistor value, RSNS	11.3kΩ
Total resistance value (R <sub>TOP</sub> + RSNS)	4.843MΩ
Resulting current through resistive divider, I <sub>CROSS</sub>	198.2μA
Resulting full-scale voltage drop across sense resistor RSNS	2.24V
Peak power dissipated in R <sub>TOP</sub> unit resistor	23.7mW
Total peak power dissipated in resistive divider	190.3mW

### 8.2.2.1 Input Filter Design

Place an RC filter in front of the device to improve signal-to-noise performance of the signal path. Input noise with a frequency close to the  $\Delta\Sigma$  modulator sampling frequency (typically 10MHz) is folded back into the low-frequency range by the modulator. The purpose of the RC filter is to attenuate high-frequency noise below the desired noise level of the measurement. In practice, a cutoff frequency that is two orders of magnitude lower than the modulator frequency yields good results.

Most voltage-sensing applications use high-impedance resistive dividers in front of the isolated modulator to scale down the input voltage. In this case, a single capacitor, as shown in Figure 8-2, is sufficient to filter the input signal. For  $(R1 + R2) \gg RSNS$ , the cutoff frequency of the input filter is  $1 / (2 \times \pi \times RSNS \times C5)$ . For example,  $RSNS = 10k\Omega$  and  $C5 = 100pF$  results in a cutoff frequency of 160kHz.

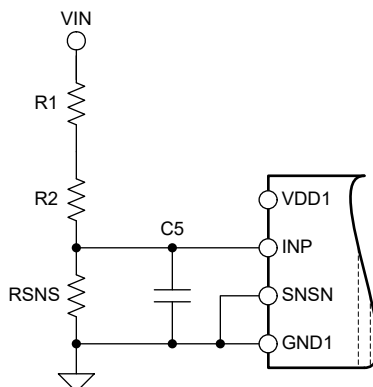


Figure 8-2. Input Filter

### 8.2.2.2 Connecting the REFIN pin

The reference input has an internal, 90k $\Omega$  impedance connected to GND2. This impedance needs to be considered when driving the REFIN pin from a high-impedance source. Connect a 100nF capacitor from REFIN to GND2 to filter out high-frequency noise at the reference input. Figure 8-3 shows different options for connecting the REFIN pin.

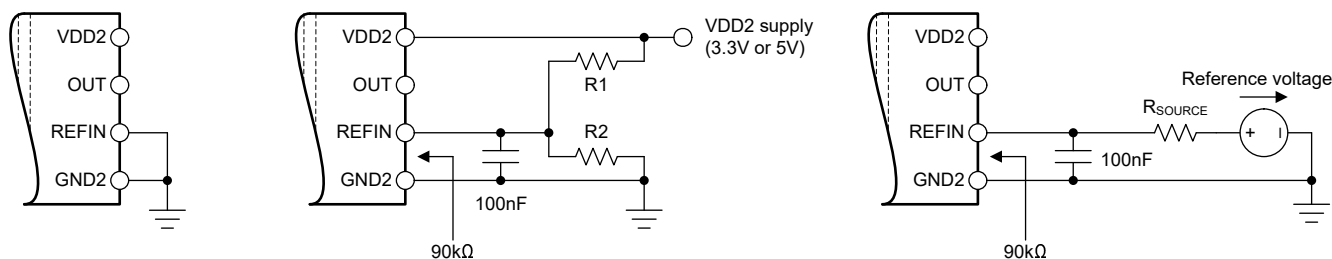


Figure 8-3. Connecting the REFIN pin

In the first example, REFIN is shorted to GND2 and the resulting reference voltage is 0V. In the second example,  $V_{REFIN}$  is derived from VDD2 through a resistive divider. In the third example, an external voltage source drives the reference input pin.

### 8.2.3 Application Curve

Figure 8-4 shows the typical full-scale step response of the AMC0x11S-Q1.

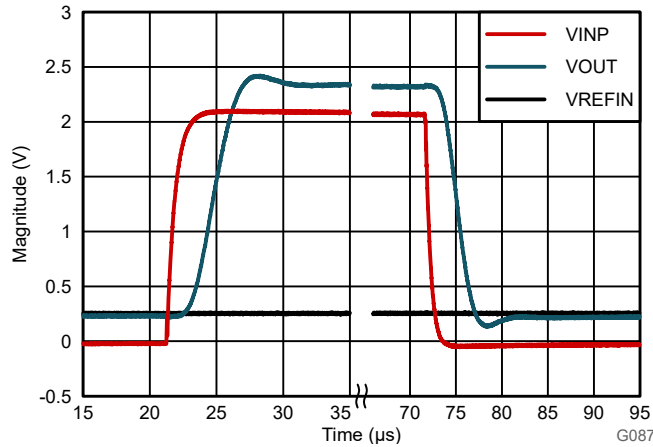


Figure 8-4. Step Response of the AMC0x11S-Q1

### 8.3 Best Design Practices

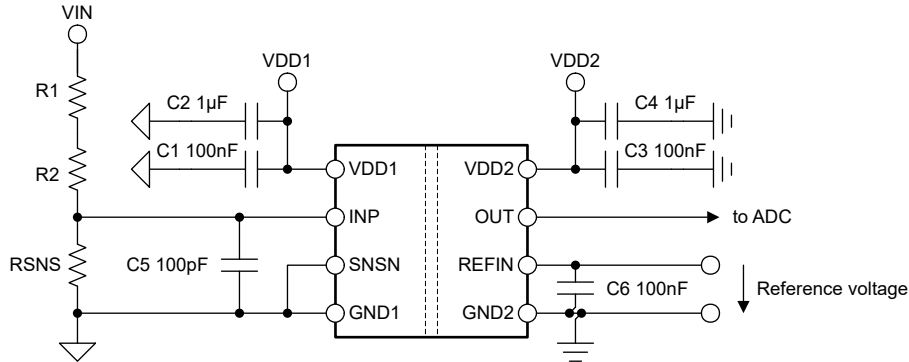
Do not leave the analog input (INP pin) of the AMC0x11S-Q1 unconnected (floating) when the device is powered up. If the device input is left floating, the output of the device is not valid.

Do not connect protection diodes to the input (INP pin) of the AMC0x11S-Q1. Diode leakage current potentially introduces significant measurement error especially at high temperatures. The input pin is protected against high voltages by the ESD protection circuit and the high impedance of the external resistive divider.

## 8.4 Power Supply Recommendations

In a typical application, the high-side power supply (VDD1) for the AMC0x11S-Q1 is generated from the low-side supply (VDD2) by an isolated DC/DC converter. A low-cost option is based on the push-pull driver [SN6501-Q1](#) and a transformer that supports the desired isolation voltage ratings.

The AMC0x11S-Q1 does not require any specific power-up sequencing. The high-side power supply (VDD1) is decoupled with a low-ESR, 100nF capacitor (C1) parallel to a low-ESR, 1μF capacitor (C2). The low-side power supply (VDD2) is equally decoupled with a low-ESR, 100nF capacitor (C3) parallel to a low-ESR, 1μF capacitor (C4). Place all four capacitors (C1, C2, C3, and C4) as close to the device as possible. [Figure 8-5](#) shows a decoupling diagram for the AMC0x11S-Q1.



**Figure 8-5. Decoupling of the AMC0x11S-Q1**

Make sure capacitors provide adequate *effective* capacitance under the applicable DC bias conditions experienced in the application. Multilayer ceramic capacitors (MLCC) typically exhibit only a fraction of the nominal capacitance under real-world conditions. Consider this factor when selecting these capacitors. This issue is especially acute in low-profile capacitors, where the dielectric field strength is higher than in taller components. Reputable capacitor manufacturers provide capacitance versus DC bias curves that greatly simplify component selection.

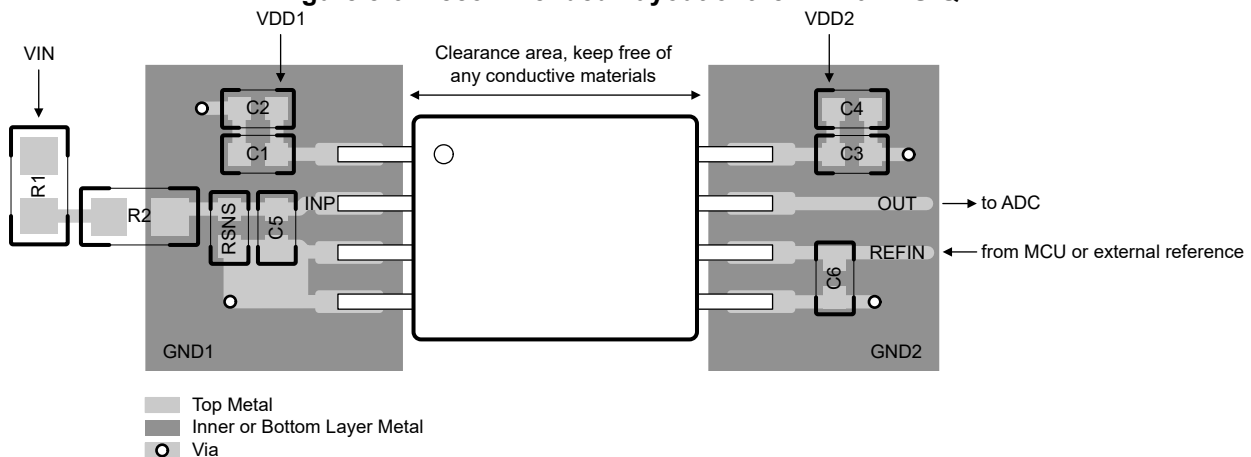
## 8.5 Layout

### 8.5.1 Layout Guidelines

The [Layout](#) section details a layout recommendation with the critical placement of the decoupling capacitors (as close as possible to the AMC0x11S-Q1 supply pins). This example also depicts the placement of other components required by the device.

### 8.5.2 Layout Example

**Figure 8-6. Recommended Layout of the AMC0x11S-Q1**



## 9 Device and Documentation Support

### 9.1 Documentation Support

#### 9.1.1 Related Documentation

For related documentation, see the following:

- Texas Instruments, [Isolation Glossary application note](#)
- Texas Instruments, [Semiconductor and IC Package Thermal Metrics application note](#)
- Texas Instruments, [ISO72x Digital Isolator Magnetic-Field Immunity application note](#)
- Texas Instruments, [18-Bit, 1-MSPS Data Acquisition Block \(DAQ\) Optimized for Lowest Distortion and Noise reference guide](#)
- Texas Instruments, [18-Bit, 1-MSPS Data Acquisition Block \(DAQ\) Optimized for Lowest Power reference guide](#)
- Texas Instruments, [Isolated Amplifier Voltage Sensing Excel Calculator design tool](#)

### 9.2 Receiving Notification of Documentation Updates

To receive notification of documentation updates, navigate to the device product folder on [ti.com](#). Click on *Notifications* to register and receive a weekly digest of any product information that has changed. For change details, review the revision history included in any revised document.

### 9.3 Support Resources

TI E2E™ [support forums](#) are an engineer's go-to source for fast, verified answers and design help — straight from the experts. Search existing answers or ask your own question to get the quick design help you need.

Linked content is provided "AS IS" by the respective contributors. They do not constitute TI specifications and do not necessarily reflect TI's views; see TI's [Terms of Use](#).

### 9.4 Trademarks

TI E2E™ is a trademark of Texas Instruments.  
All trademarks are the property of their respective owners.

### 9.5 Electrostatic Discharge Caution



This integrated circuit can be damaged by ESD. Texas Instruments recommends that all integrated circuits be handled with appropriate precautions. Failure to observe proper handling and installation procedures can cause damage.

ESD damage can range from subtle performance degradation to complete device failure. Precision integrated circuits may be more susceptible to damage because very small parametric changes could cause the device not to meet its published specifications.

### 9.6 Glossary

[TI Glossary](#) This glossary lists and explains terms, acronyms, and definitions.

## 10 Revision History

NOTE: Page numbers for previous revisions may differ from page numbers in the current version.

Changes from Revision * (October 2024) to Revision A (May 2025)	Page
• Updated the numbering format for tables, figures, and cross-references through the document.....	1
• Changed the device status from <i>Advanced</i> to <i>Production</i> .....	1

## 11 Mechanical, Packaging, and Orderable Information

The following pages include mechanical, packaging, and orderable information. This information is the most current data available for the designated devices. This data is subject to change without notice and revision of this document. For browser-based versions of this data sheet, refer to the left-hand navigation.

**PACKAGING INFORMATION**

Orderable part number	Status (1)	Material type (2)	Package   Pins	Package qty   Carrier	RoHS (3)	Lead finish/ Ball material (4)	MSL rating/ Peak reflow (5)	Op temp (°C)	Part marking (6)
<a href="#">PAMC0311SQDWVRQ1</a>	Active	Preproduction	SOIC (DWV)   8	1000   LARGE T&R	-	Call TI	Call TI	-40 to 125	
PAMC0311SQDWVRQ1.A	Active	Preproduction	SOIC (DWV)   8	1000   LARGE T&R	-	Call TI	Call TI	See PAMC0311SQDWVRQ1	
PAMC0311SQDWVRQ1.B	Active	Preproduction	SOIC (DWV)   8	1000   LARGE T&R	-	Call TI	Call TI	See PAMC0311SQDWVRQ1	

(1) **Status:** For more details on status, see our [product life cycle](#).

(2) **Material type:** When designated, preproduction parts are prototypes/experimental devices, and are not yet approved or released for full production. Testing and final process, including without limitation quality assurance, reliability performance testing, and/or process qualification, may not yet be complete, and this item is subject to further changes or possible discontinuation. If available for ordering, purchases will be subject to an additional waiver at checkout, and are intended for early internal evaluation purposes only. These items are sold without warranties of any kind.

(3) **RoHS values:** Yes, No, RoHS Exempt. See the [TI RoHS Statement](#) for additional information and value definition.

(4) **Lead finish/Ball material:** Parts may have multiple material finish options. Finish options are separated by a vertical ruled line. Lead finish/Ball material values may wrap to two lines if the finish value exceeds the maximum column width.

(5) **MSL rating/Peak reflow:** The moisture sensitivity level ratings and peak solder (reflow) temperatures. In the event that a part has multiple moisture sensitivity ratings, only the lowest level per JEDEC standards is shown. Refer to the shipping label for the actual reflow temperature that will be used to mount the part to the printed circuit board.

(6) **Part marking:** There may be an additional marking, which relates to the logo, the lot trace code information, or the environmental category of the part.

Multiple part markings will be inside parentheses. Only one part marking contained in parentheses and separated by a "-" will appear on a part. If a line is indented then it is a continuation of the previous line and the two combined represent the entire part marking for that device.

**Important Information and Disclaimer:**The information provided on this page represents TI's knowledge and belief as of the date that it is provided. TI bases its knowledge and belief on information provided by third parties, and makes no representation or warranty as to the accuracy of such information. Efforts are underway to better integrate information from third parties. TI has taken and continues to take reasonable steps to provide representative and accurate information but may not have conducted destructive testing or chemical analysis on incoming materials and chemicals. TI and TI suppliers consider certain information to be proprietary, and thus CAS numbers and other limited information may not be available for release.

In no event shall TI's liability arising out of such information exceed the total purchase price of the TI part(s) at issue in this document sold by TI to Customer on an annual basis.

**OTHER QUALIFIED VERSIONS OF AMC0311S-Q1 :**

- Catalog : [AMC0311S](#)

NOTE: Qualified Version Definitions:

- Catalog - TI's standard catalog product

## IMPORTANT NOTICE AND DISCLAIMER

TI PROVIDES TECHNICAL AND RELIABILITY DATA (INCLUDING DATA SHEETS), DESIGN RESOURCES (INCLUDING REFERENCE DESIGNS), APPLICATION OR OTHER DESIGN ADVICE, WEB TOOLS, SAFETY INFORMATION, AND OTHER RESOURCES "AS IS" AND WITH ALL FAULTS, AND DISCLAIMS ALL WARRANTIES, EXPRESS AND IMPLIED, INCLUDING WITHOUT LIMITATION ANY IMPLIED WARRANTIES OF MERCHANTABILITY, FITNESS FOR A PARTICULAR PURPOSE OR NON-INFRINGEMENT OF THIRD PARTY INTELLECTUAL PROPERTY RIGHTS.

These resources are intended for skilled developers designing with TI products. You are solely responsible for (1) selecting the appropriate TI products for your application, (2) designing, validating and testing your application, and (3) ensuring your application meets applicable standards, and any other safety, security, regulatory or other requirements.

These resources are subject to change without notice. TI grants you permission to use these resources only for development of an application that uses the TI products described in the resource. Other reproduction and display of these resources is prohibited. No license is granted to any other TI intellectual property right or to any third party intellectual property right. TI disclaims responsibility for, and you will fully indemnify TI and its representatives against, any claims, damages, costs, losses, and liabilities arising out of your use of these resources.

TI's products are provided subject to [TI's Terms of Sale](#) or other applicable terms available either on [ti.com](https://www.ti.com) or provided in conjunction with such TI products. TI's provision of these resources does not expand or otherwise alter TI's applicable warranties or warranty disclaimers for TI products.

TI objects to and rejects any additional or different terms you may have proposed.

Mailing Address: Texas Instruments, Post Office Box 655303, Dallas, Texas 75265  
Copyright © 2025, Texas Instruments Incorporated